

euro It | *HYBRIDS*

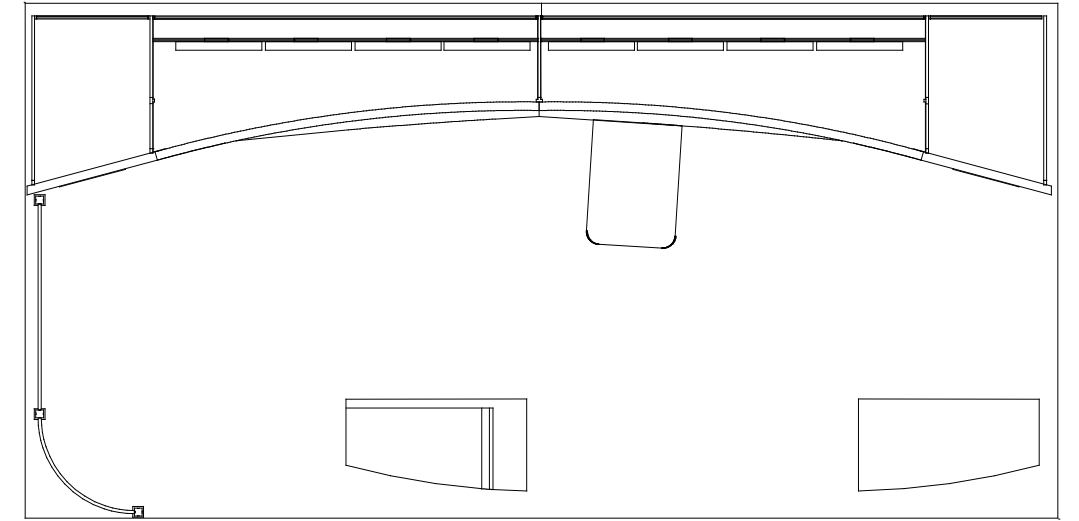

Plan View

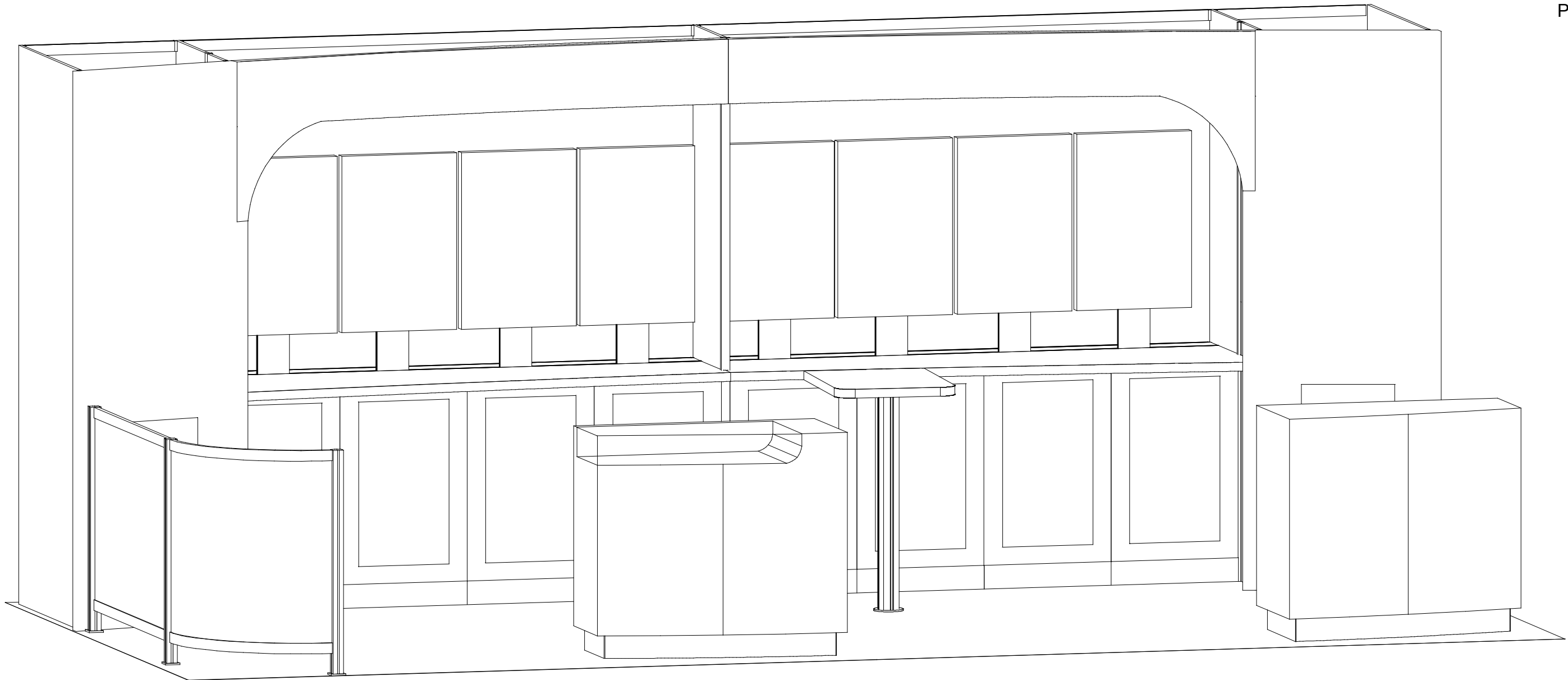

WHEN DISASSEMBLING ALUMINUM EXTRUSION, TIGHTEN ALL SETSCREWS AND LOCKS TO PREVENT LOSS DURING SHIPPING

euro lt | HYBRIDS

Using Your Setup Instructions

The Euro LT Hybrids Setup Instructions are created specifically for your configuration. They are laid out sequentially in levels, including exploded views, and a logical series of detailed steps to assemble the main structure and components. We encourage you to study the instructions **before** attempting to assemble your exhibit.

Each page reminds you to tighten the setscrews after disassembling your exhibit to prevent loss of the locks and setscrews (see below in RED). This is VERY IMPORTANT.

Cleaning and Packing Your Display

- 1) Use care when cleaning aluminum extrusion or acrylic inserts. Use only non-abrasive cleaners.
- 2) When cleaning laminate inserts, countertops, or panels use mild cleansers and a soft material such as cotton.
- 3) Keep all display components away from extreme heat and long exposure to sunlight to avoid warping and fading.
- 4) Retain all packing material. It will make re-packing much easier and will reduce the likelihood of shipping damage.

General Setup Instructions for Extrusion System



The Tool

Most exhibits can be assembled with the supplied Hex Key Tool. Occasionally, a flat head screwdriver may be required.



Typical Connection

Most horizontal extrusion connections have a patented expandable lock. This lock inserts into the groove of an opposing extrusion. Tightening the lock with the Hex Key Tool expands the lock and creates a strong positive connection.



Typical Connection (cont'd)

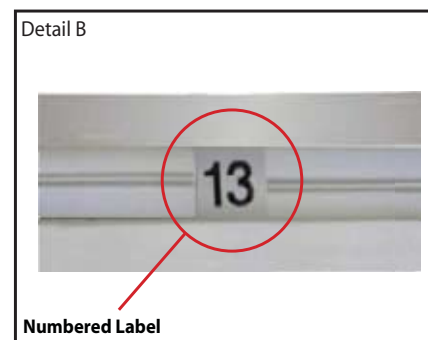

Numbered Label

Each extrusion contains a numbered label which corresponds with setup instructions. The label is located within a groove of the extrusion (when possible). With extrusion components the labels contain Black numbers unless otherwise specified.



Horizontal Inline Connection (remove only one setscrew)

Remove only (1) setscrew when disassembling. Replace setscrew in extrusion after assembling it. Before packing, replace setscrew in extrusion to avoid losing it.

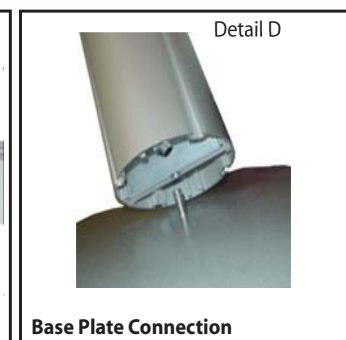

Base Plate Connection

Attach base plate to round or square vertical extrusion using the bolt provided. Be careful not to strip the threads.

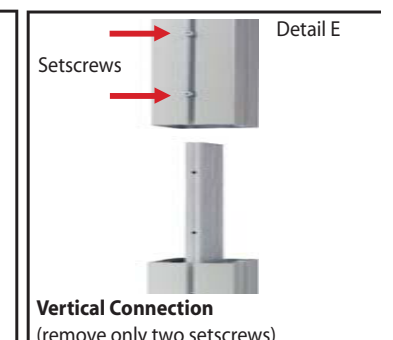

Vertical Connection (remove only two setscrews)

When vertical extrusions are packed in portable cases rather than crates or tubs, they must be broken down into smaller section which then require assembly.

Remove only (2) setscrews when disassembling. Replace setscrews in extrusion after assembling it. Before packing, replace setscrews in extrusion to avoid losing them.

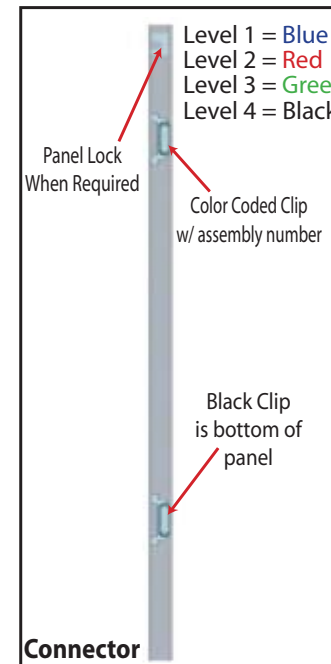

Connector

Each component has 2 clips, the lower clip is ALWAYS black. The top clip is color coded to distinguish which level. The color coded clip also contains the numbered label.

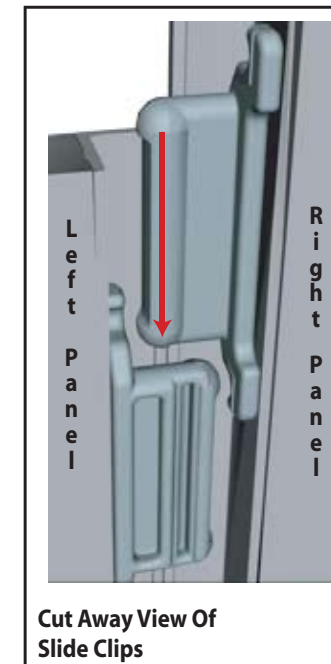

Cut Away View Of Slide Clips

Components connect together by aligning them and sliding downward connecting clips together.

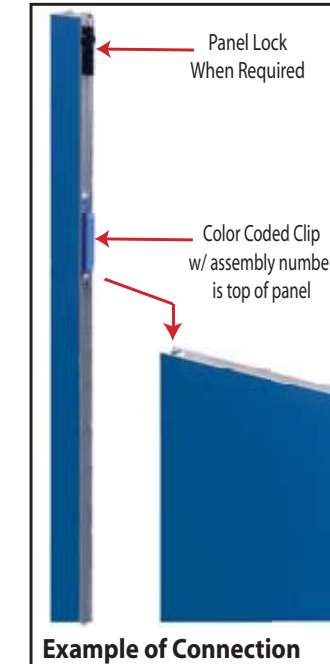

Example of Connection

Configurations are assembled from left to right, usually starting with #1 and following the numbered sequence.

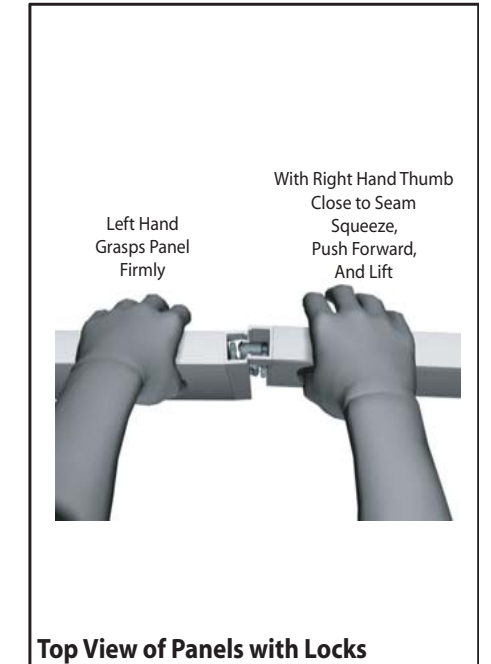

Top View of Panels with Locks

The first level of components contain panel locks that are located at the top of the panel for extra stability and seamless connection. When disassembling panels twist top connection slightly and lift right panel upward.

WHEN DISASSEMBLING ALUMINUM EXTRUSION, TIGHTEN ALL SETSCREWS AND LOCKS TO PREVENT LOSS DURING SHIPPING

866.652.2100

Item	Qty.	Description
1	1	38.3378"w x 95"h Flat Panel
2	2	25.9254"w Extrusion
3	1	19.5"w x 95"h Flat Panel
4	1	95"h Milled Off T- Connector
5	1	10.475"w x 95"h Flat Panel
6/6A	2/1	88.6028"w Extrusion/88.6028"w Extrusion w/ Holes for Counter Connection
7	1	19.5"w x 95"h Flat Panel
8	1	22.1620"w x 38"h Flat Door Panel
9	1	22.1620"w x 38"h Flat Door Panel
10	1	22.1620"w x 38"h Flat Door Panel
11	1	22.1620"w x 38"h Flat Door Panel
12	1	95"h Milled Off T- Connector

Steps

- 1) Connect horizontal extrusions [2] between panels [1 and 3] refer to Detail A on General Info page.
- 2) Attach connector and panel [4 and 5] to panel [3] as shown below.
- 3) Connect horizontal extrusions [6 and 6A] between panels [3 and 7] refer to Detail A on General Info page.
- 4) Attach door panels [8 thru 11] together then attach connector [12].
- 5) Attach shelf supports as shown then place shelf atop supports.

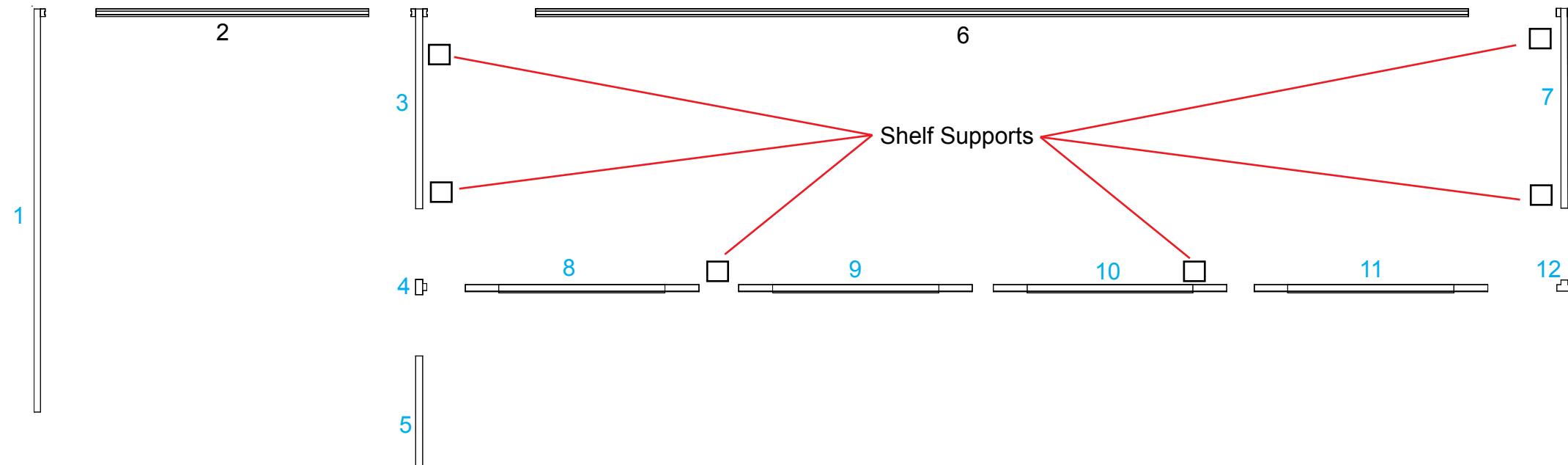
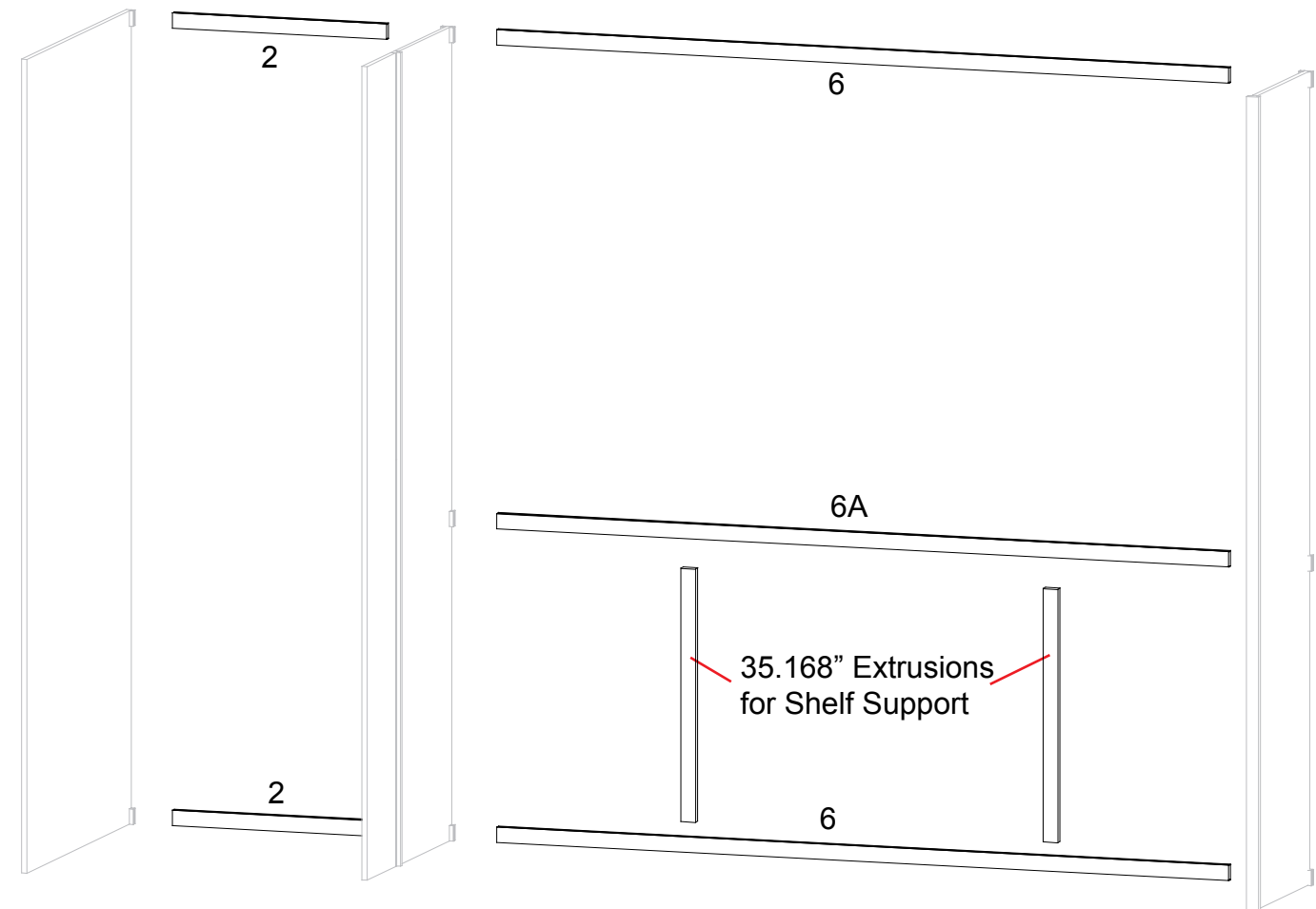

WHEN DISASSEMBLING ALUMINUM EXTRUSION, TIGHTEN ALL SETSCREWS AND LOCKS TO PREVENT LOSS DURING SHIPPING

866.652.2100

Item	Qty.	Description
13/13A	2/1	88.6028"w Extrusion/88.6028"w Extrusion w/ Holes for Counter Connection
14	1	19.5"w x 95"h Flat Panel
15	1	22.1620"w x 38"h Flat Door Panel
16	1	22.1620"w x 38"h Flat Door Panel
17	1	22.1620"w x 38"h Flat Door Panel
18	1	22.1620"w x 38"h Flat Door Panel
19	1	95"h Milled Off T- Connector
20	1	10.475"w x 95"h Flat Panel
21	2	25.9254"w Extrusion
22	1	38.3378"w x 95"h Flat Panel

Steps

- 1) Connect horizontal extrusions [13 and 13A] between panels [12 and 14] refer to Detail A on General Info page.
- 2) Attach door panels [15 thru 18] together then attach connector [19].
- 3) Attach panel [20] to connector [19] as shown below.
- 4) Connect horizontal extrusions [21] between panels [14 and 22] refer to Detail A on General Info page.
- 5) Attach shelf supports as shown then place shelf atop supports.

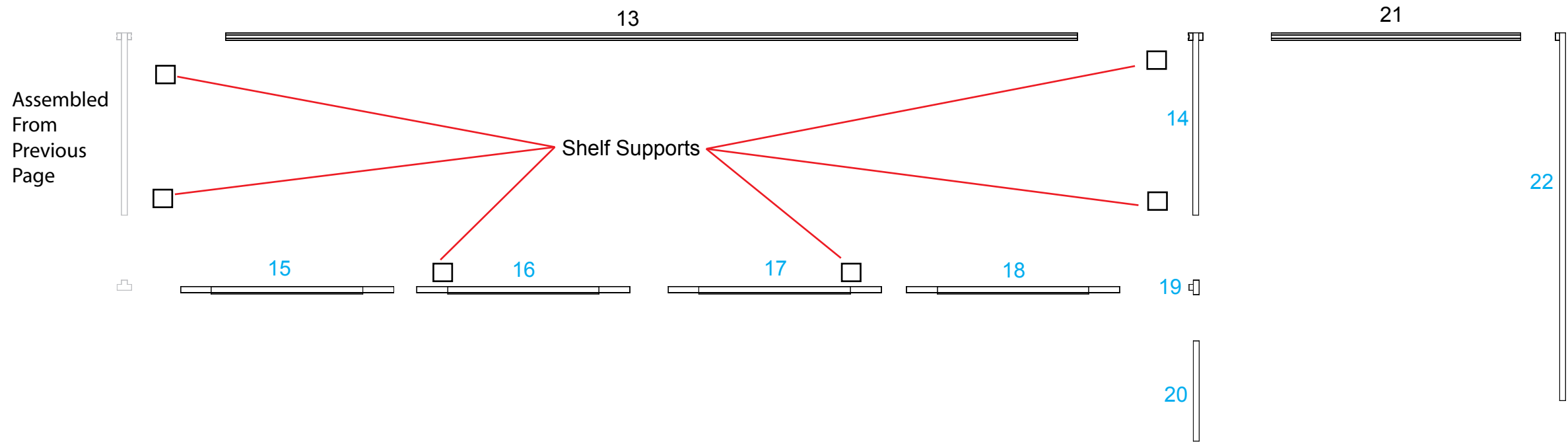
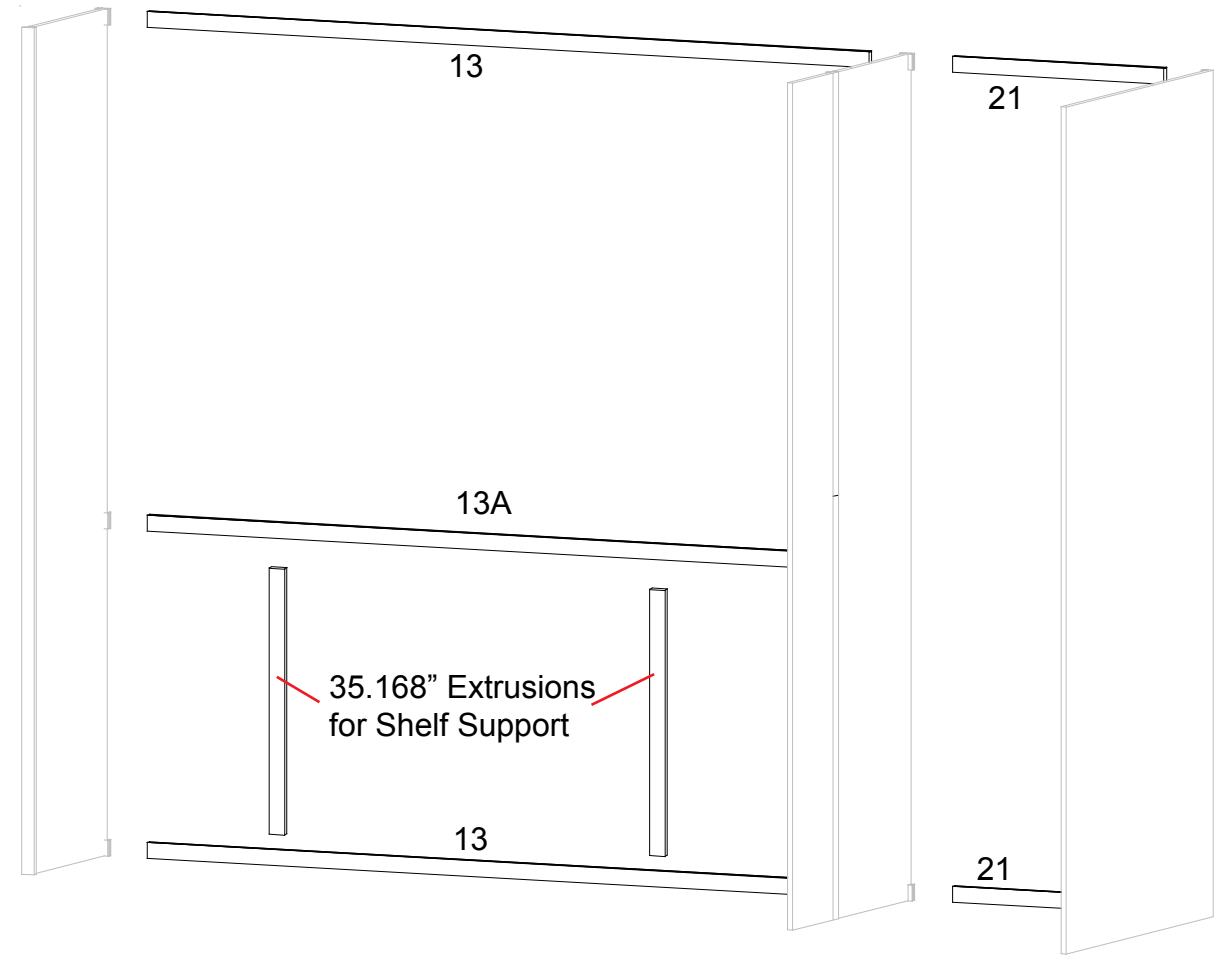

WHEN DISASSEMBLING ALUMINUM EXTRUSION, TIGHTEN ALL SETSCREWS AND LOCKS TO PREVENT LOSS DURING SHIPPING

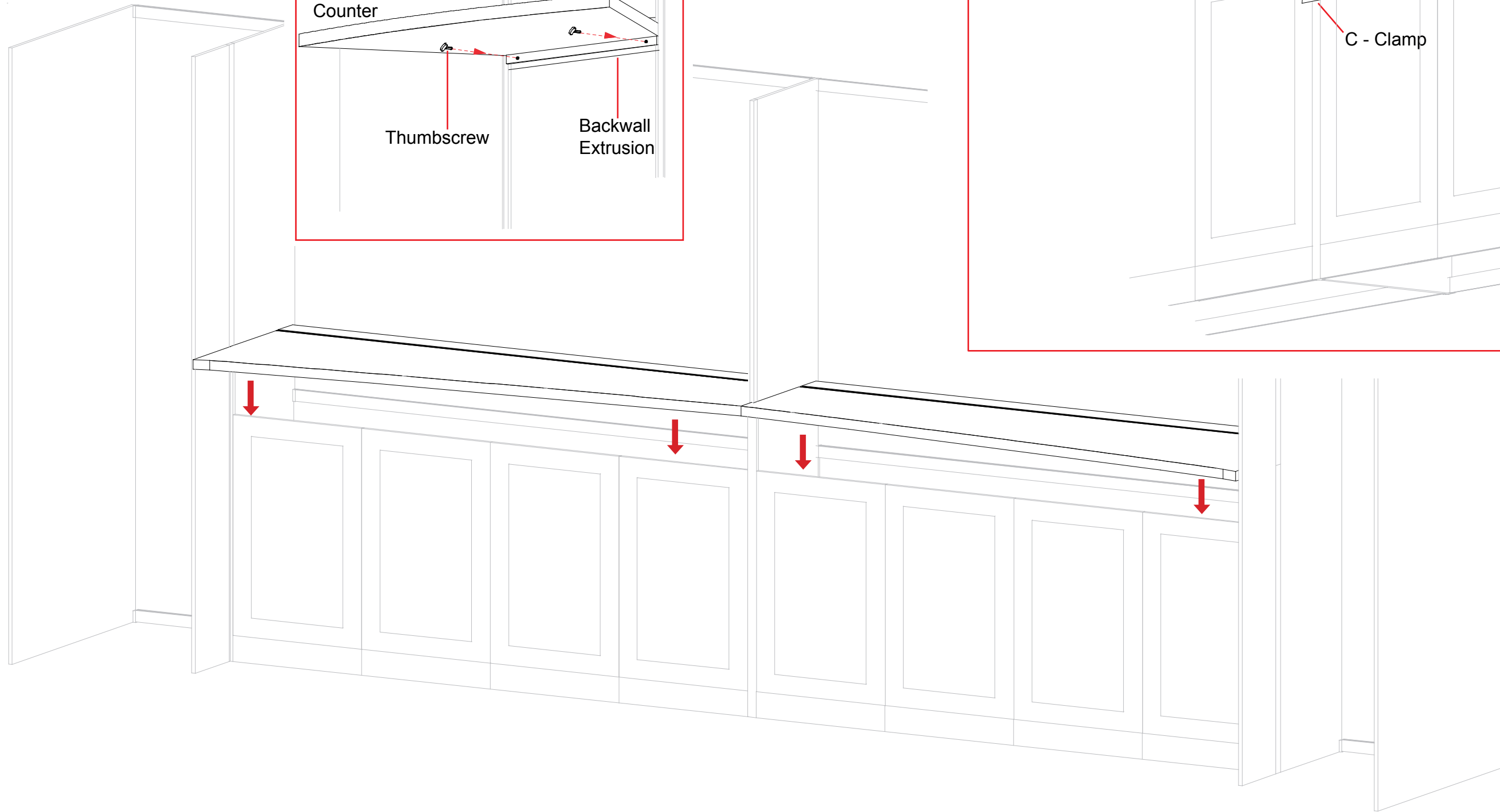
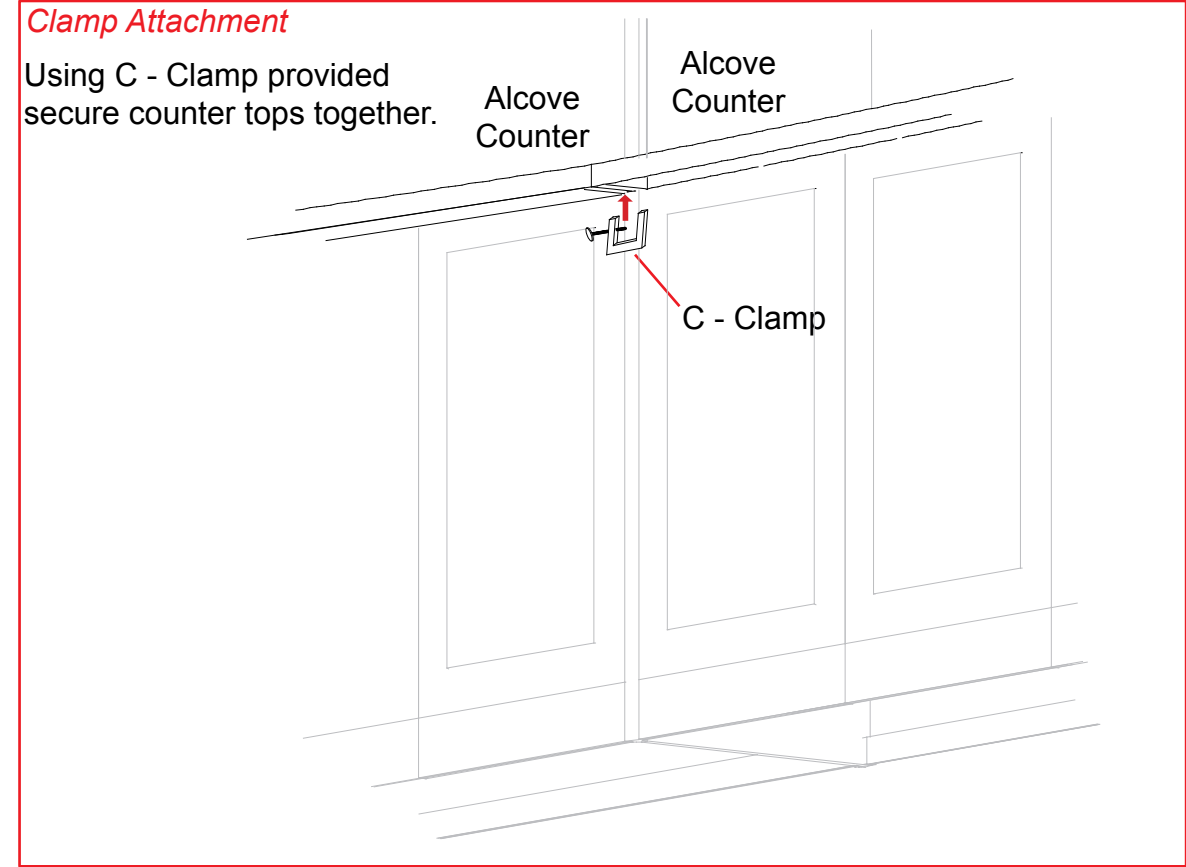
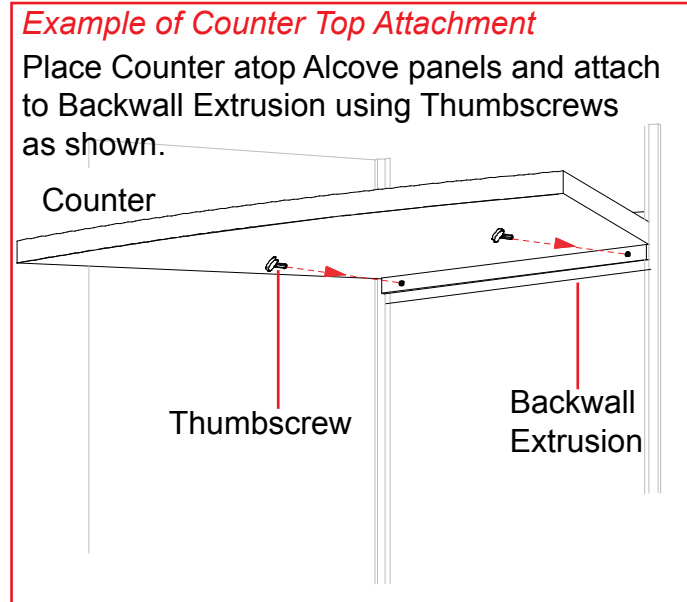

WHEN DISASSEMBLING ALUMINUM EXTRUSION, TIGHTEN ALL SETSCREWS AND LOCKS TO PREVENT LOSS DURING SHIPPING

866.652.2100

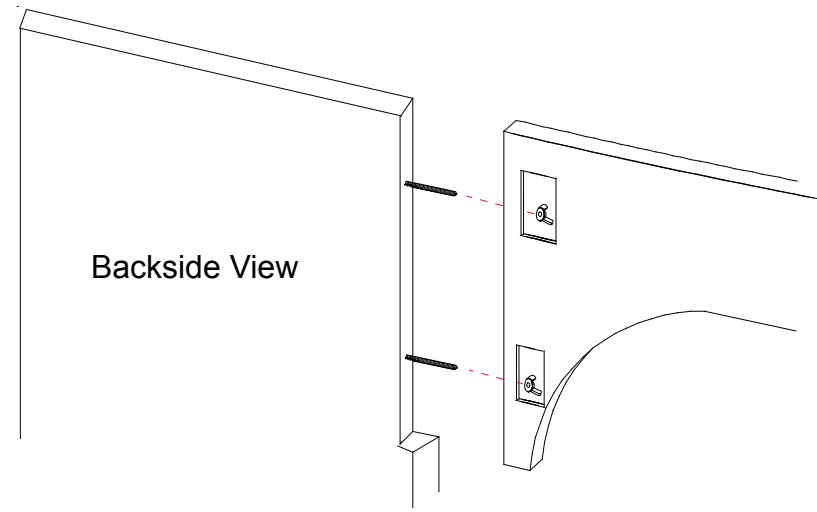

Connect pieces together by sliding header piece over threaded studs and secure into place using wing nuts

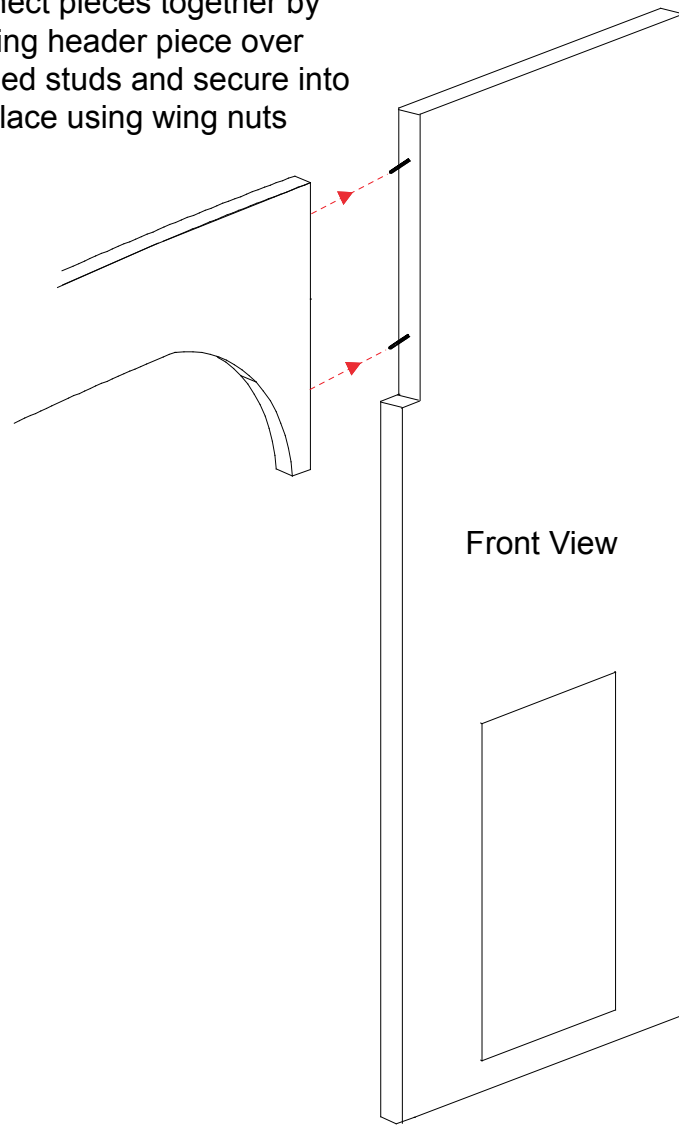

Center of Header pieces attach to connector piece via hooks. 1 hook is shorter than the other to allow for both to fit into groove of connector.

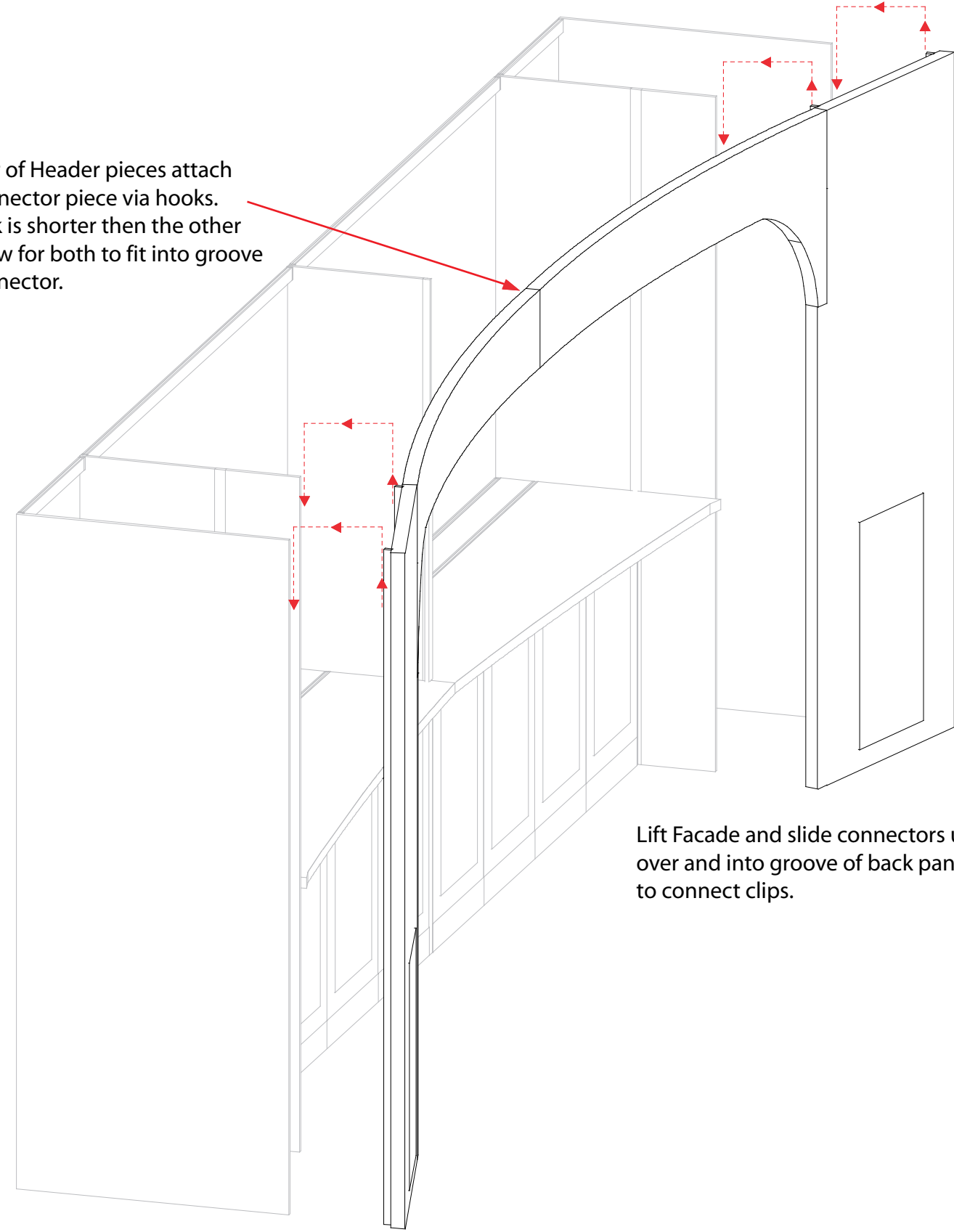

WHEN DISASSEMBLING ALUMINUM EXTRUSION, TIGHTEN ALL SETSCREWS AND LOCKS TO PREVENT LOSS DURING SHIPPING

Item	Qty.	Description
24	1	Base Plate
25	1	37.75" h Vertical Extrusion

866.652.2100

Steps

- 1) Connect vertical extrusion [25] to base plate [24] refer to Detail D on General Info Page.
- 2) Attach counter to leg as shown below.
- 3) Using clamps provided attach counter assembly to backwall.

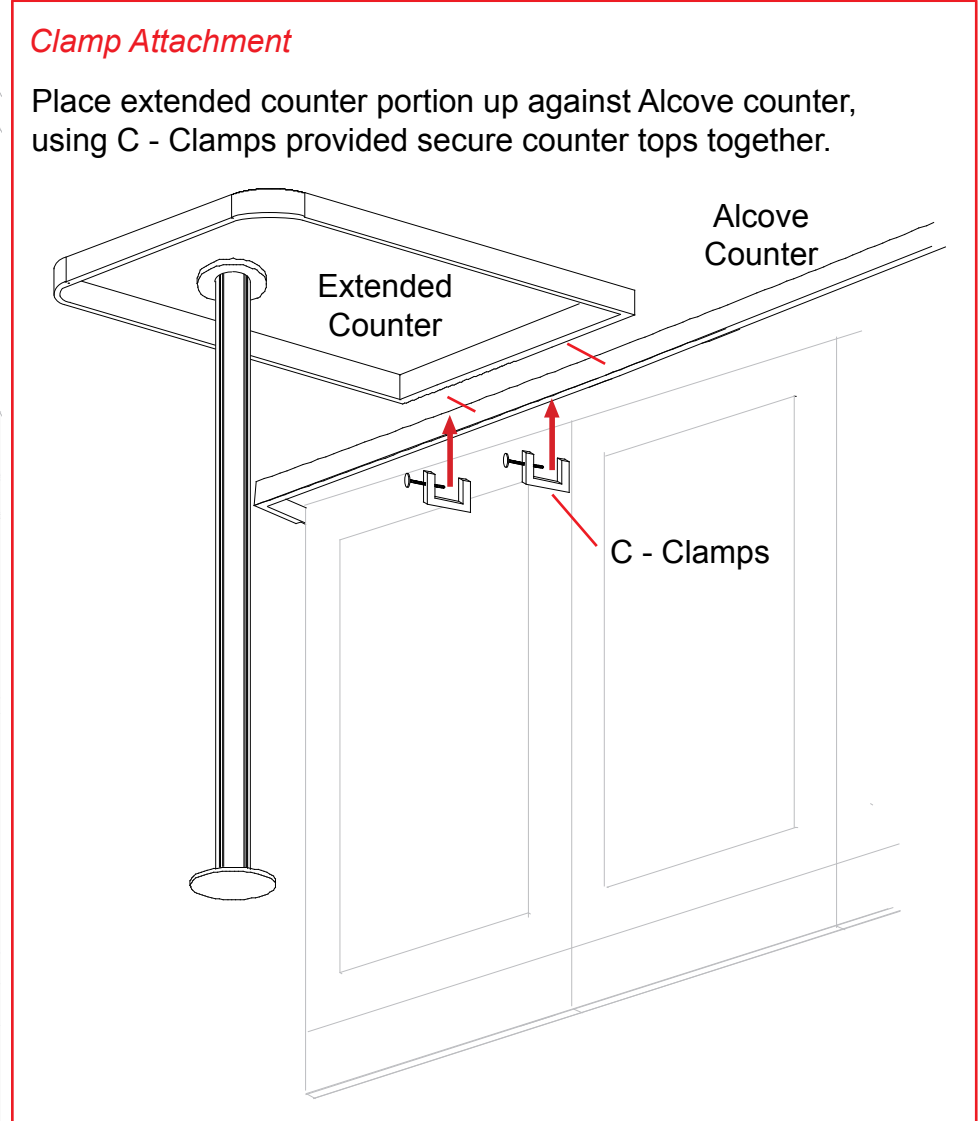
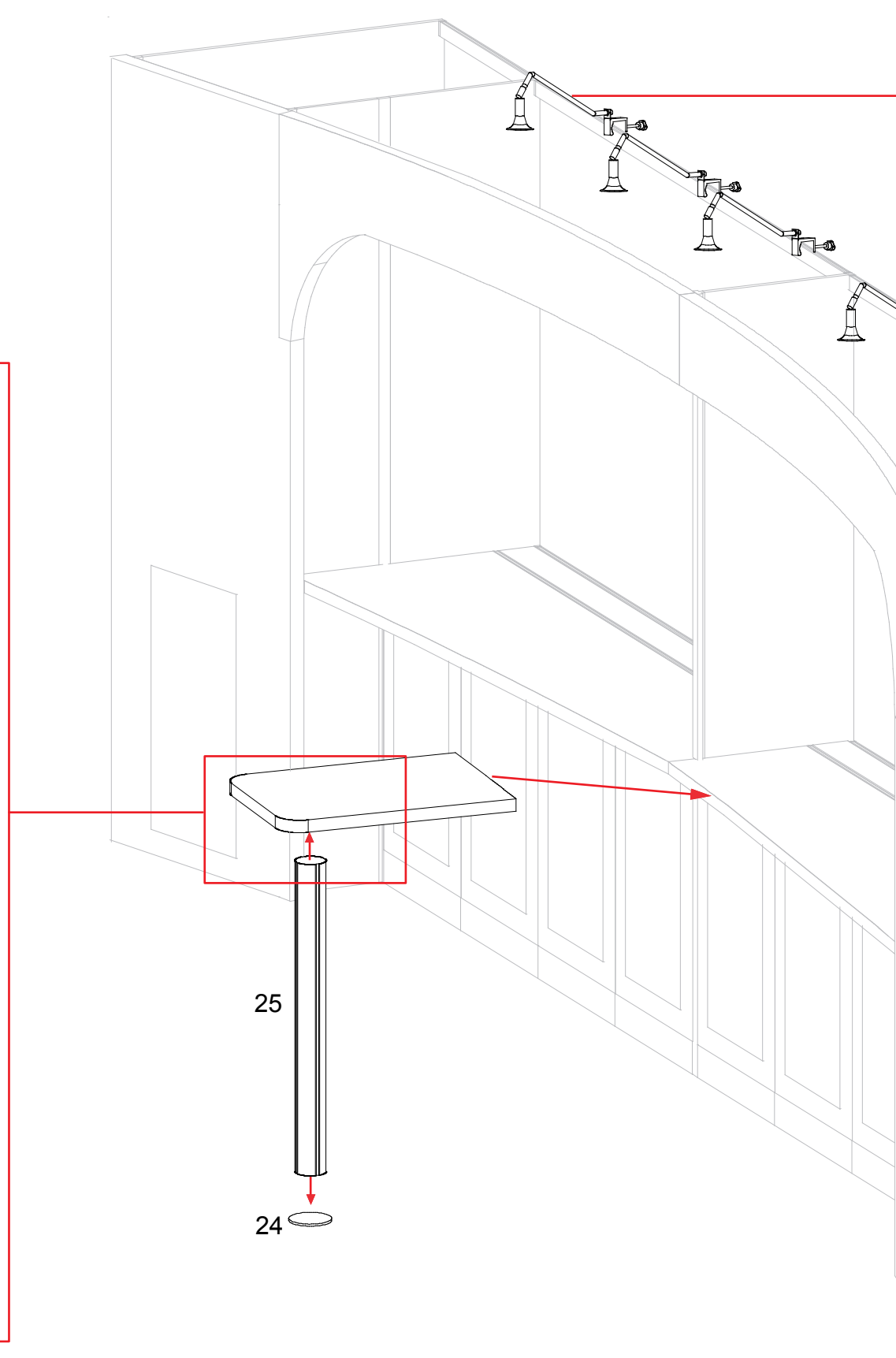
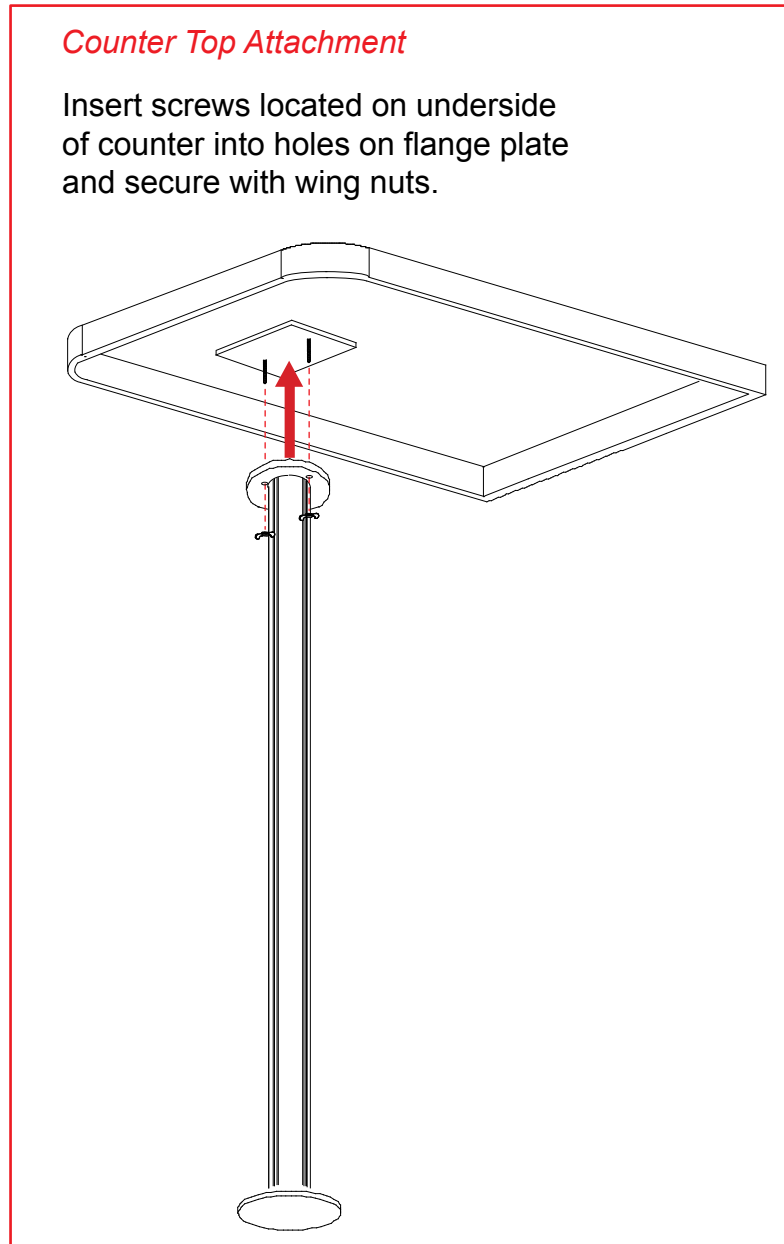
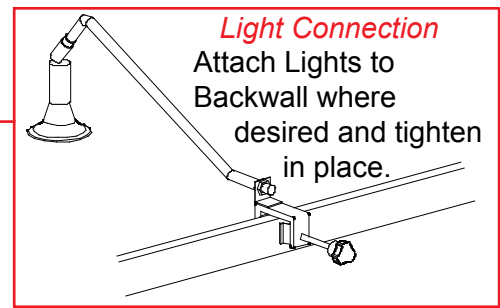

WHEN DISASSEMBLING ALUMINUM EXTRUSION, TIGHTEN ALL SETSCREWS AND LOCKS TO PREVENT LOSS DURING SHIPPING

866.652.2100

Item	Qty.	Description
23	8	24" Extrusion
23A	16	Mount Extrusion

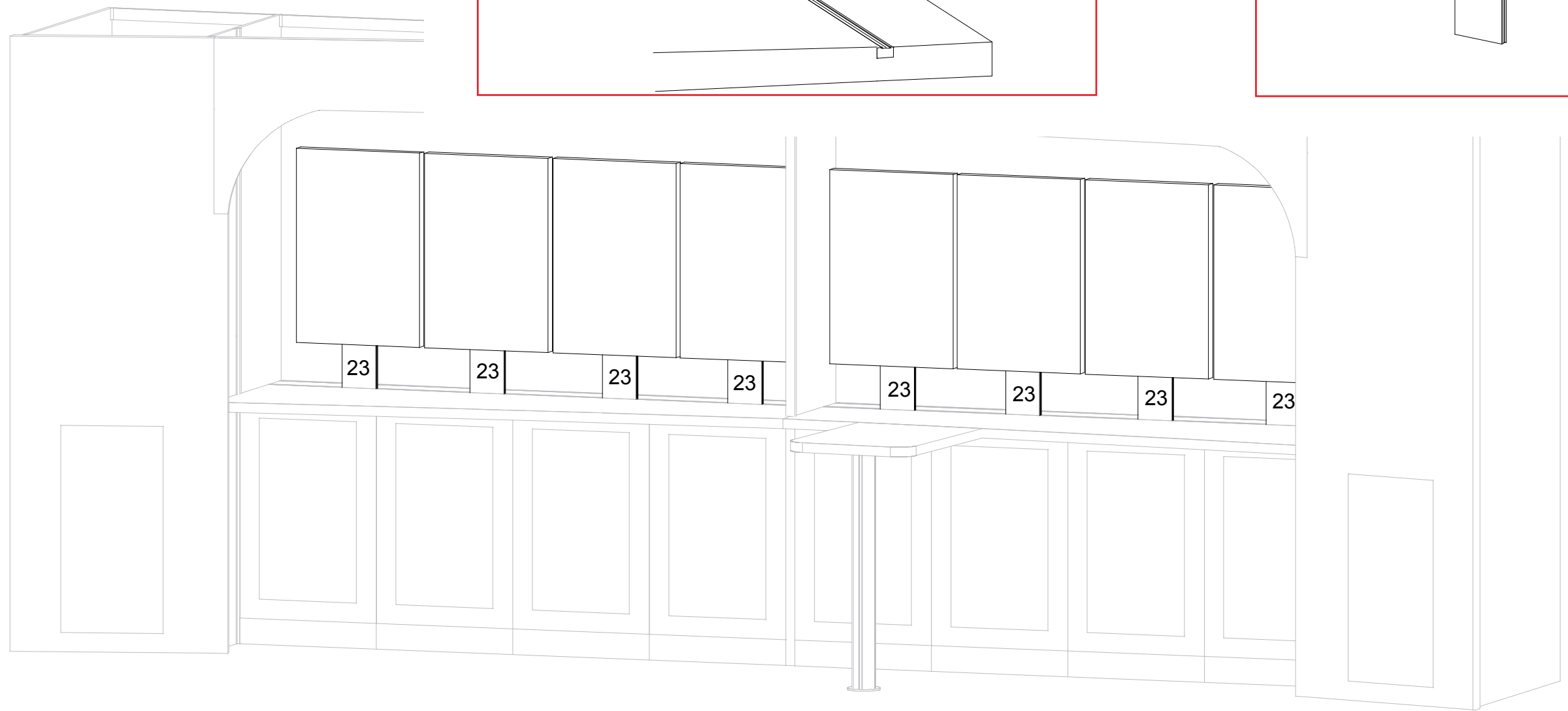
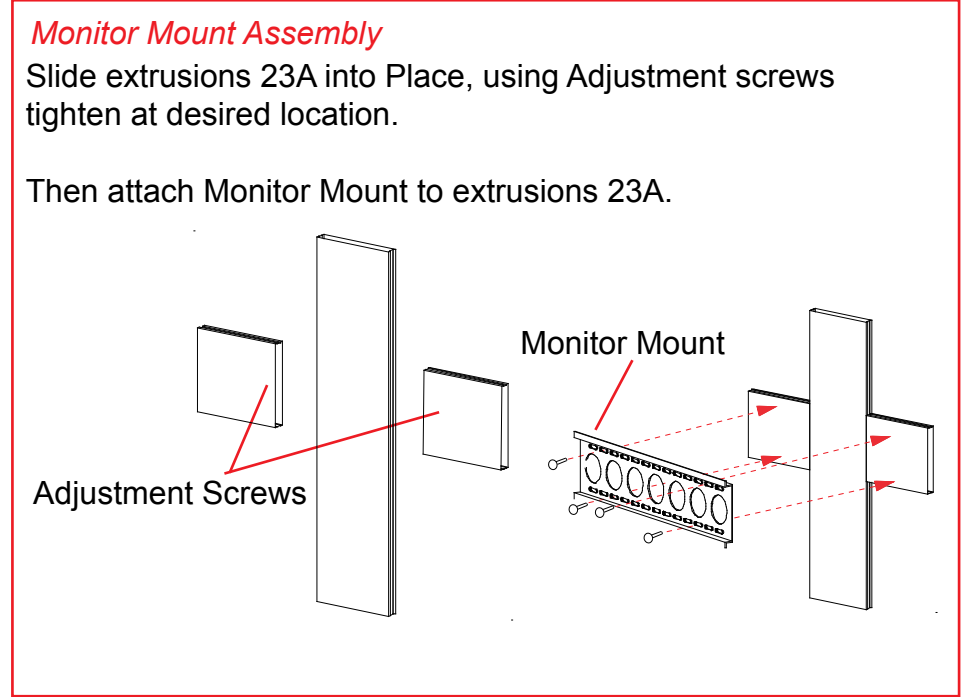
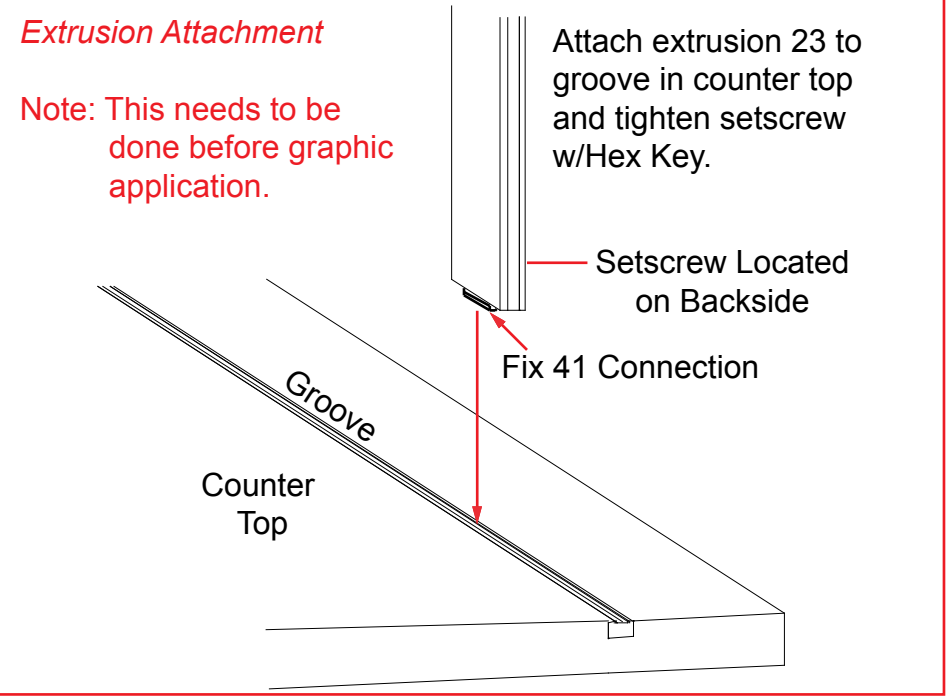

WHEN DISASSEMBLING ALUMINUM EXTRUSION, TIGHTEN ALL SETSCREWS AND LOCKS TO PREVENT LOSS DURING SHIPPING

Item	Qty.	Description
26	3	Base Plate
27	3	38" h Vertical Extrusion
28	2	48" w Horizontal Extrusion
29	2	35.145" w Curved Horizontal Extrusion

Steps

- 1) Connect vertical extrusions [27] to base plates [26] refer to Detail D on General Info Page.
- 2) Connect horizontal extrusions [28] between verticals [27] placing insert as shown.
- 3) Connect curved horizontal extrusions [29] between verticals [27] placing insert as shown.
- 4) At this point attach graphics to Backwall, refer to detail at right and reference 1st Backwall setup page.

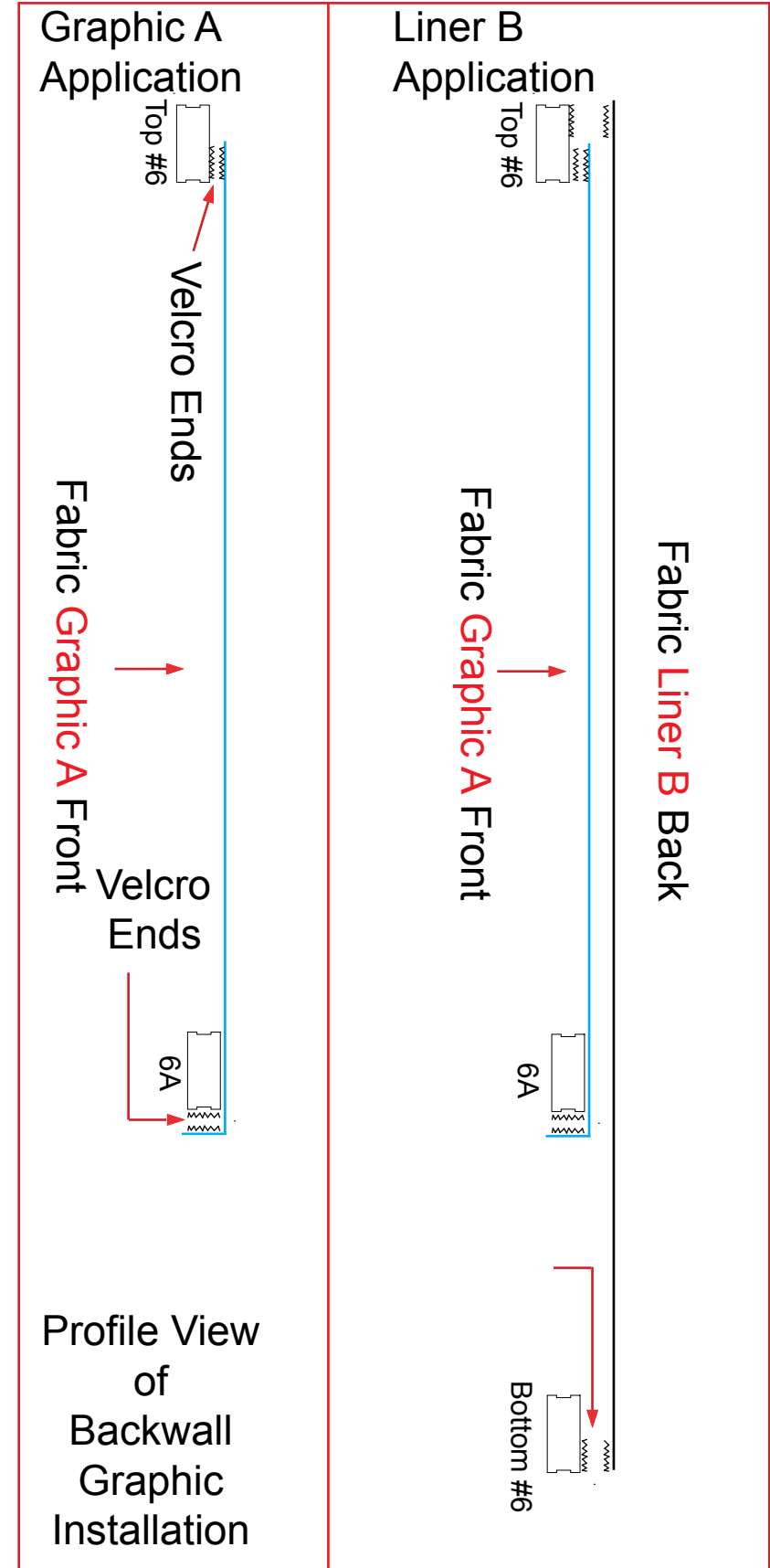
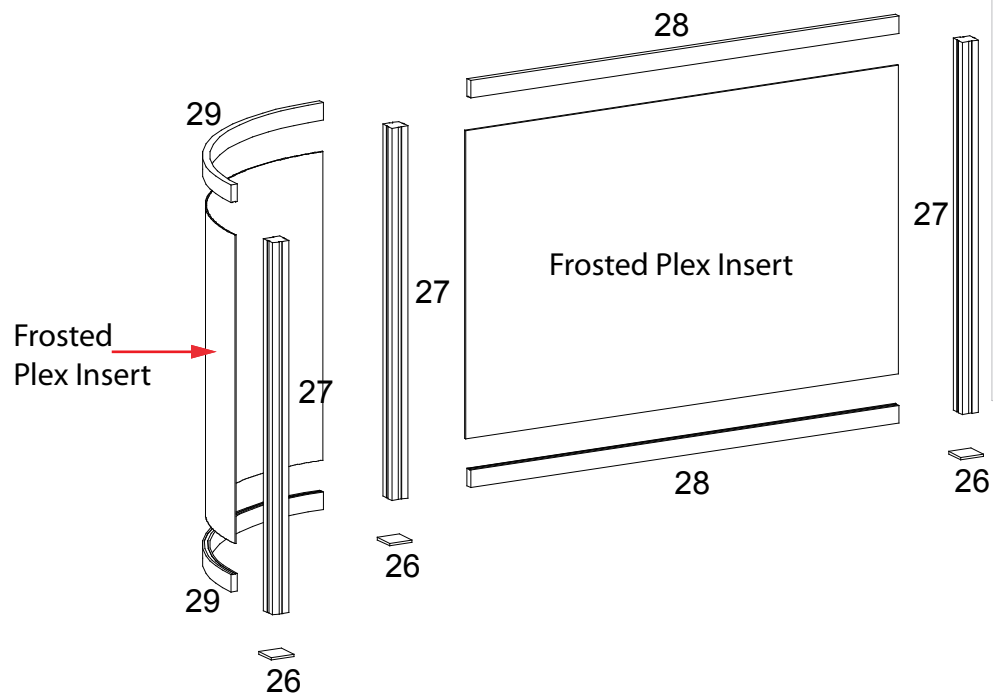

WHEN DISASSEMBLING ALUMINUM EXTRUSION, TIGHTEN ALL SETSCREWS AND LOCKS TO PREVENT LOSS DURING SHIPPING

866.652.2100

Place Clear Plex Top
in Place securing short
side to Velcro.

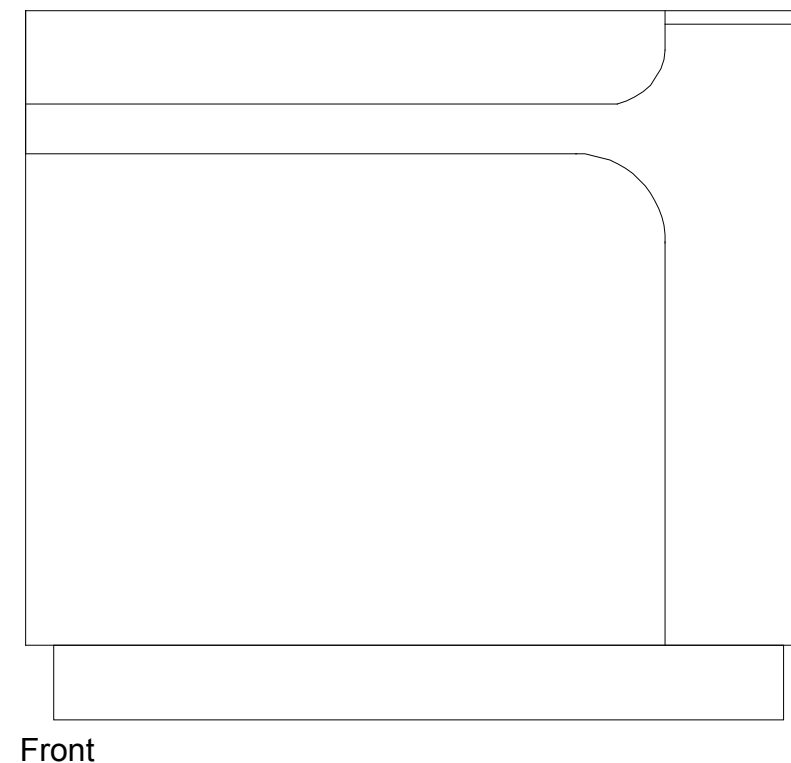
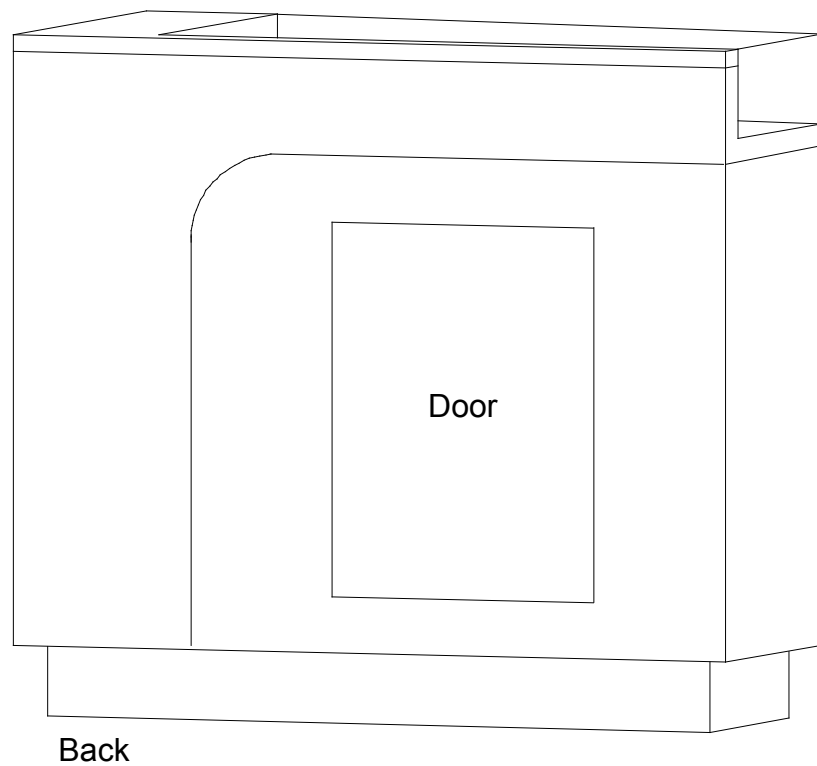
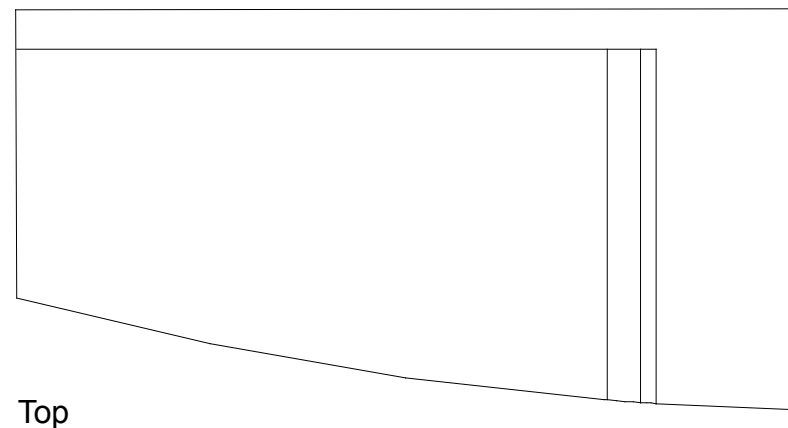
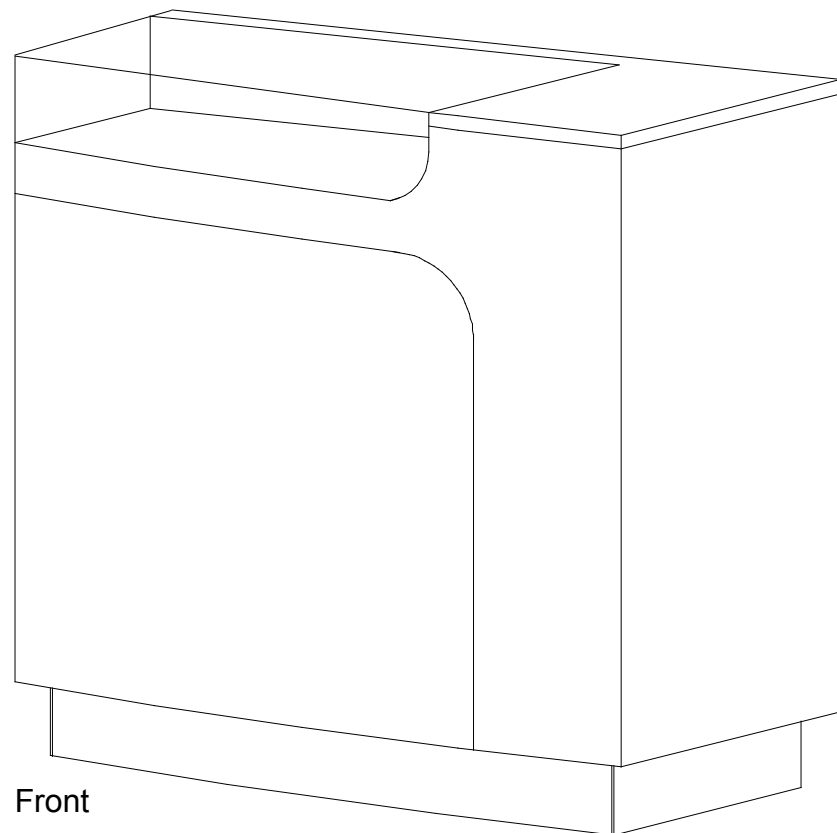

WHEN DISASSEMBLING ALUMINUM EXTRUSION, TIGHTEN ALL SETSCREWS AND LOCKS TO PREVENT LOSS DURING SHIPPING

866.652.2100

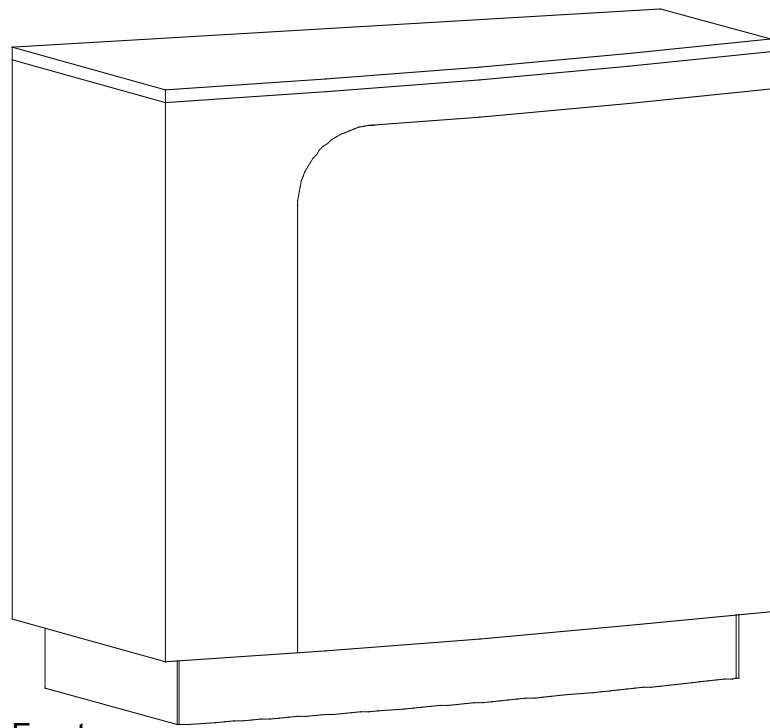

Front

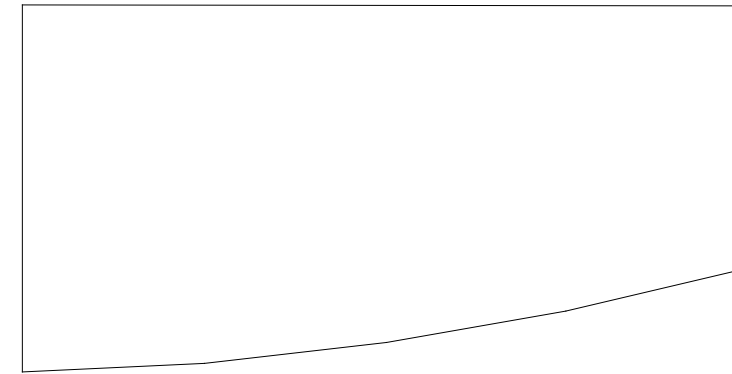

Top

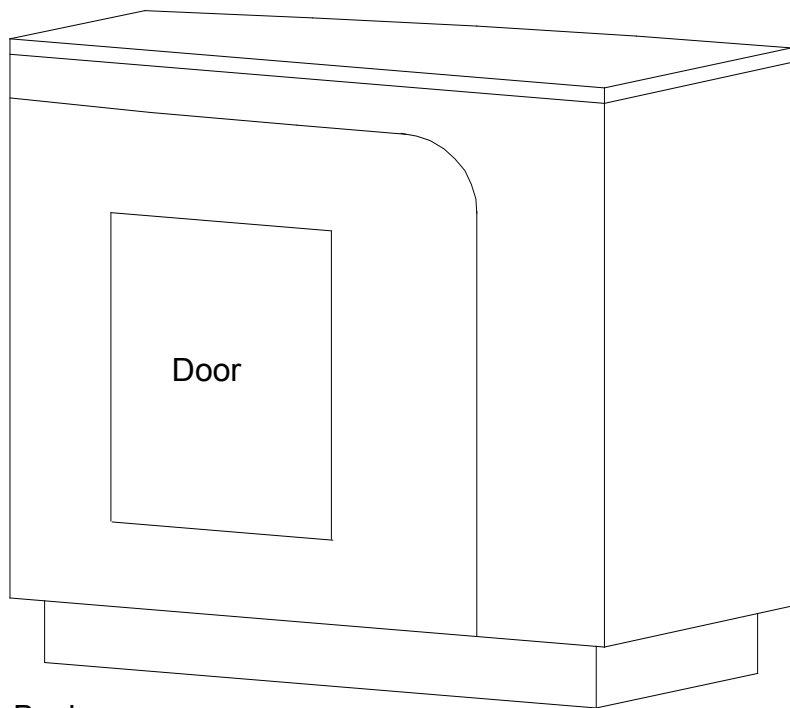

Back

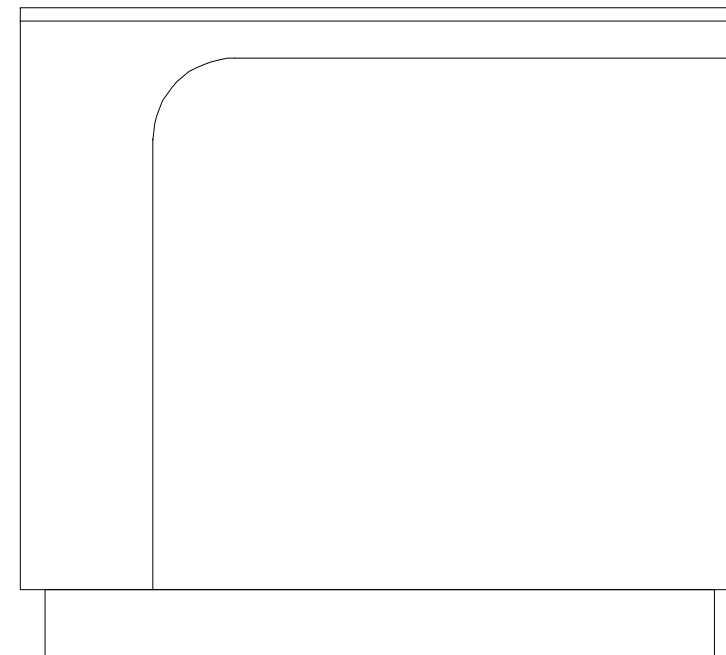

Front

WHEN DISASSEMBLING ALUMINUM EXTRUSION, TIGHTEN ALL SETSCREWS AND LOCKS TO PREVENT LOSS DURING SHIPPING

- Left Side
- A- Front Door Panels (8, 9, 10, 11)
 - B- Backwall Extrusions and Corral Wall (2, 6, 6A, 27, 28, 29)
 - C- Backwall Panel (1)
 - D- Backwall Panel (5)
 - E- T-Connector (4)
 - F- 90° Connector for 10 x 10 reconfigure (12A)
 - G- Backwall Panel (3)
 - H- Backwall Panel for 10 x 10 reconfigure(7A)
 - I- Light Box/Monitor Mounts (23) qty:4
(23A) qty: 8

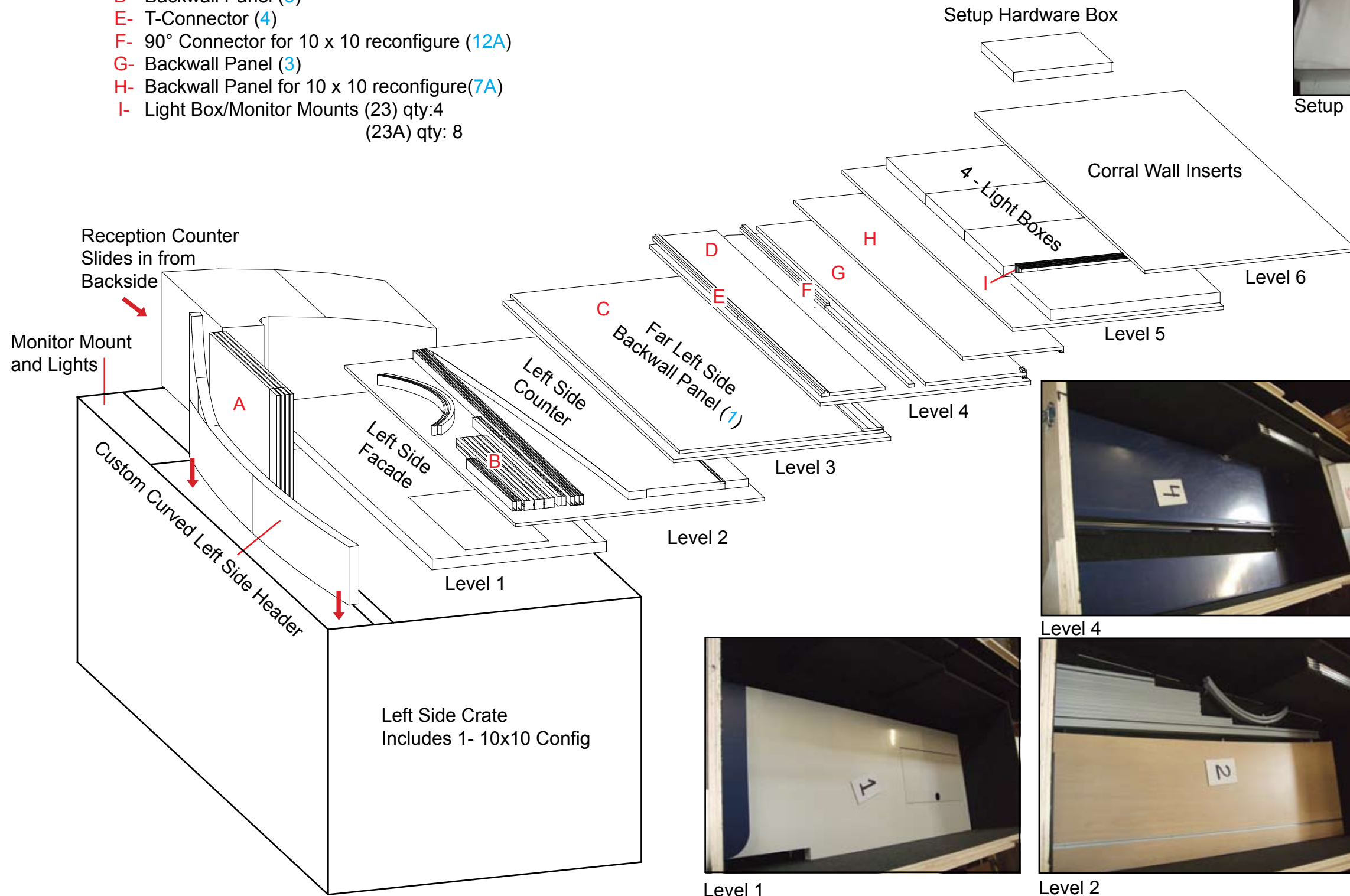

Setup Hardware Box



Level 6



Level 4



Level 5



Level 1



Level 2



Level 3

Left Side Crate
Includes 1- 10x10 Config

WHEN DISASSEMBLING ALUMINUM EXTRUSION, TIGHTEN ALL SETSCREWS AND LOCKS TO PREVENT LOSS DURING SHIPPING

Right Side

- A- Front Door Panels (15, 16, 17, 18)
- B- Backwall Extrusions (13, 13A, 21)
- C- Backwall Panel (22)
- D- Backwall Panel (20)
- E- T-Connector (19)
- F- T-Connector (12)
- G- 90° Connector for 10 x 10 reconfigure (12B)
- H- Backwall Panel (14)
- I- Backwall Panel (7)
- J- Backwall Panel for 10 x 10 for 10 x 10 reconfigure (7B)
- K- Round Extrusion (24/25)
- L- Light Box/Monitor Mounts (23) qty:4
(23A) qty: 8

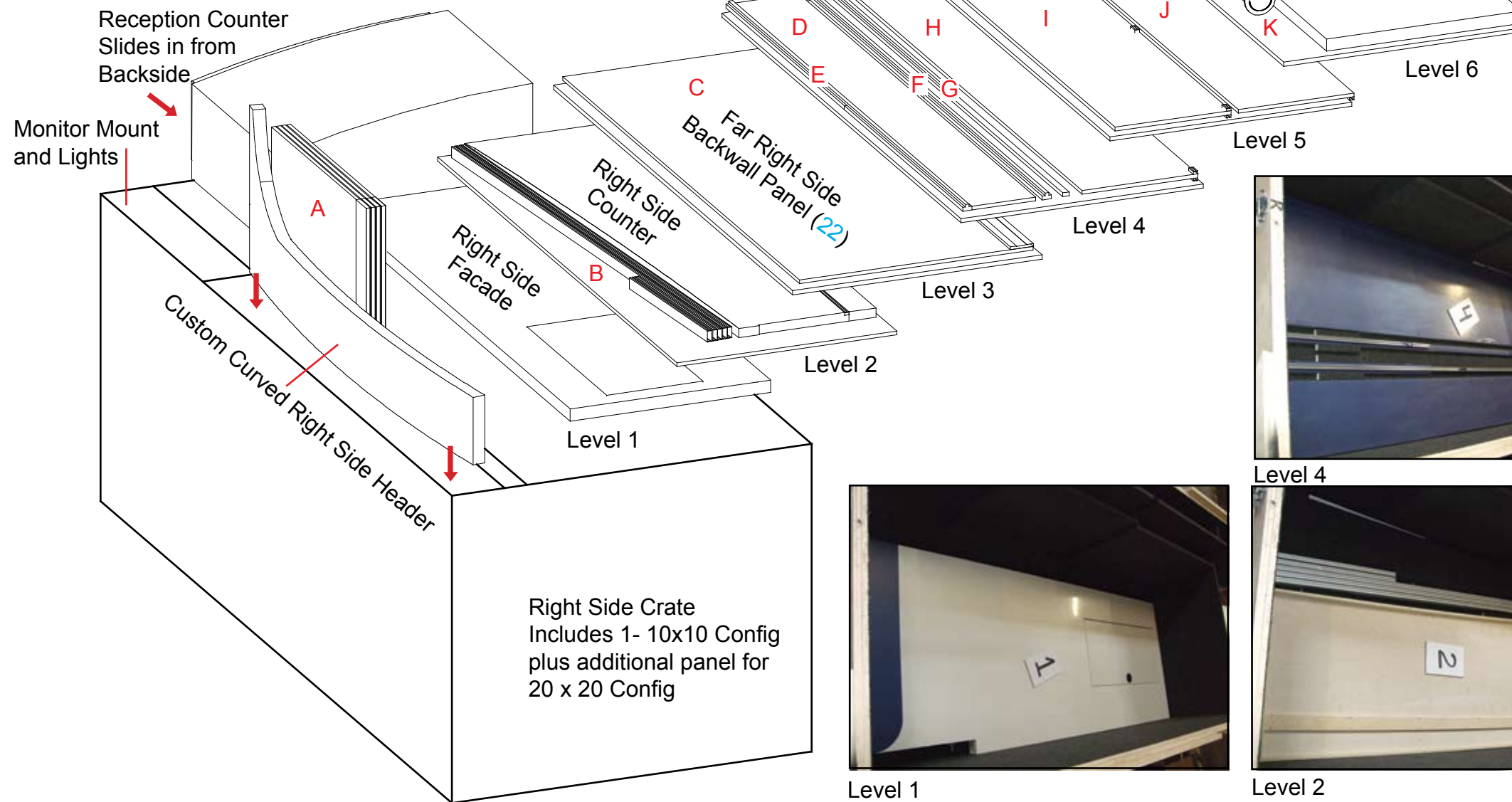

Right Side Crate
Includes 1- 10x10 Config
plus additional panel for
20 x 20 Config

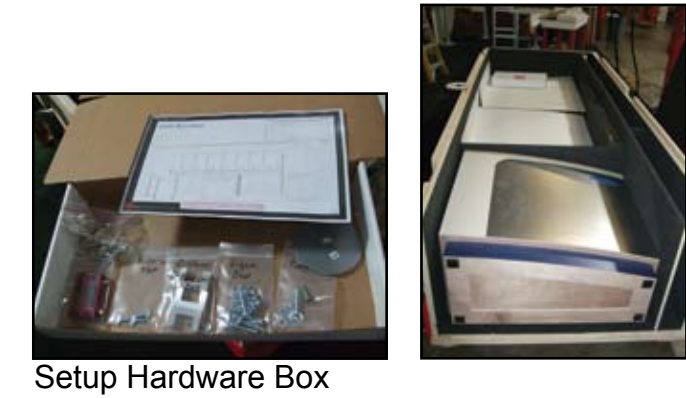

WHEN DISASSEMBLING ALUMINUM EXTRUSION, TIGHTEN ALL SETSCREWS AND LOCKS TO PREVENT LOSS DURING SHIPPING