

visionary[™]
DESIGNS

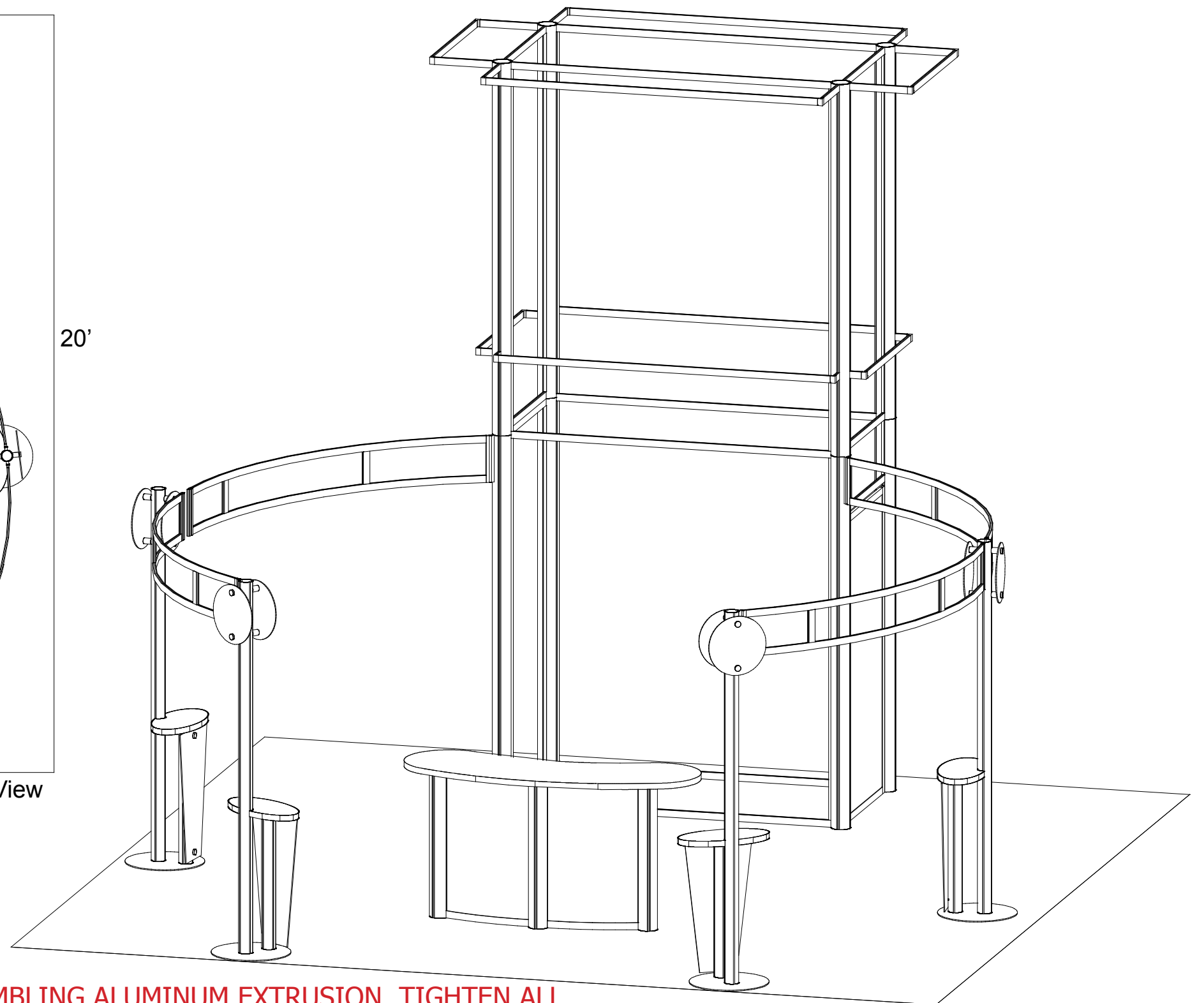
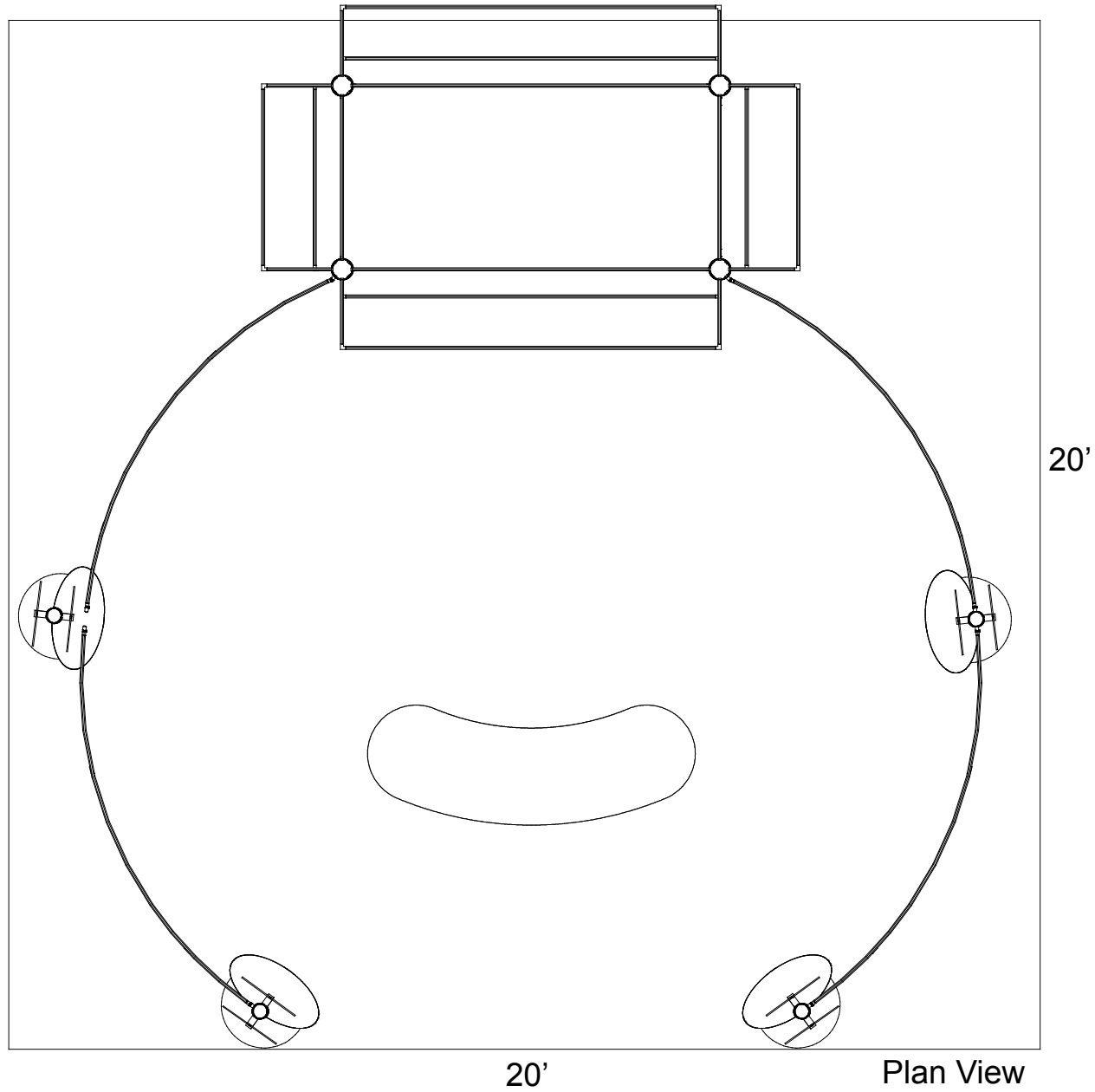

WHEN DISASSEMBLING ALUMINUM EXTRUSION, TIGHTEN ALL SETSCREWS AND LOCKS TO PREVENT LOSS DURING SHIPPING

visionary™ IDESIGNS

Using Your Setup Instructions

The Visionary Designs Setup Instructions are created specifically for your configuration. They are laid out sequentially, including an exploded view of the entire display, and then a logical series of detailed steps to assemble the main structure and components. We encourage you to study the instructions **before** attempting to assemble your exhibit.

Each page reminds you to tighten the setscrews after disassembling your exhibit to prevent loss of the locks and setscrews (see below in RED). This is **VERY IMPORTANT**.

Cleaning and Packing Your Display

- 1) Use care when cleaning aluminum extrusion or acrylic inserts. Use only non-abrasive cleaners.
- 2) When cleaning laminate inserts or countertops, use mild cleansers and a soft material such as cotton.
- 3) Keep all display components away from extreme heat and long exposure to sunlight to avoid warping and fading.
- 4) Retain all packing material. It will make re-packing much easier and will reduce the likelihood of shipping damage.



The Tool

Most Visionary Designs exhibits can be assembled with the supplied Hex Key Tool. Occasionally, a flat head screwdriver may be required.



Typical Connection

Most horizontal extrusion connections have a patented expandable lock. This lock inserts into the groove of an opposing extrusion. Tightening the lock with the Hex Key Tool expands the lock and creates a strong positive connection.



Typical Connection (cont'd)

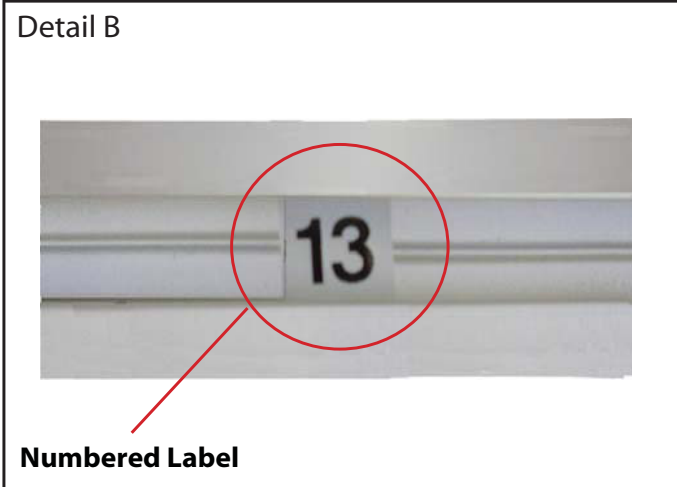

Numbered Label

Each extrusion contains a numbered label which corresponds with setup instructions. The label is located within a groove of the extrusion (when possible). With Visionary Designs the labels contain Black numbers unless otherwise specified.



Horizontal Inline Connection (remove only one setscrew)

Remove only (1) setscrew when disassembling. Replace setscrew in extrusion after assembling it. Before packing, replace setscrew in extrusion to avoid losing it.

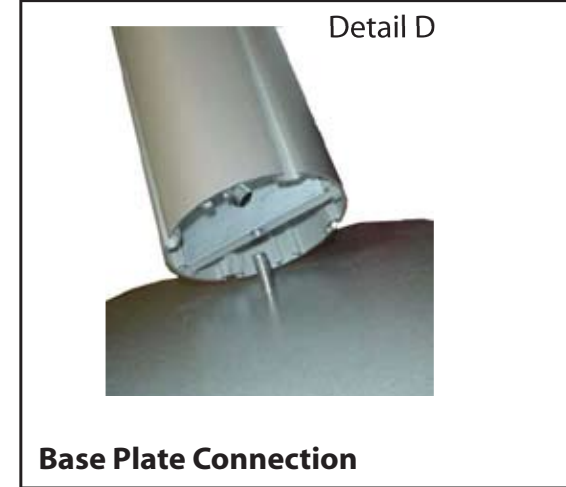

Base Plate Connection

Attach base plate to round or square vertical extrusion using the bolt provided. Be careful not to strip the threads.

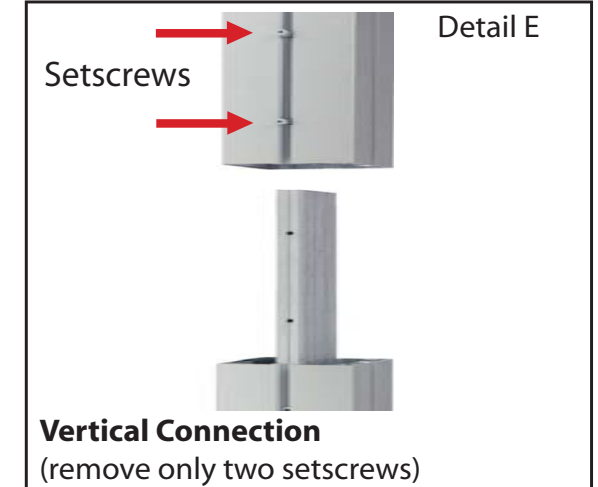

Vertical Connection
(remove only two setscrews)

When vertical extrusions are packed in portable cases rather than crates or tubs, they must be broken down into smaller sections which then require assembly.

Remove only (2) setscrews when disassembling. Replace setscrews in extrusion after assembling it. Before packing, replace setscrews in extrusion to avoid losing them.

WHEN DISASSEMBLING ALUMINUM EXTRUSION, TIGHTEN ALL SETSCREWS AND LOCKS TO PREVENT LOSS DURING SHIPPING

Part Number	Qty	Description
1	1	96" h Lower Vertical extrusion
2	1	96" h Upper Vertical extrusion
3	1	96" h Lower Vertical extrusion
4	1	96" h Upper Vertical extrusion
5	1	96" h Lower Vertical extrusion
6	1	96" h Upper Vertical extrusion
7	1	96" h Lower Vertical extrusion
8	1	96" h Upper Vertical extrusion
9	4	83" Horizontal extrusion
10	4	38" Horizontal extrusion
11	2	83" Horizontal extrusion
12	3	38" Horizontal extrusion

Steps: (Note: Sections highlighted in Light Brown should ship assembled.)

- 1) Attach upper verticals [2, 4, 6, and 8] atop lower verticals [1, 3, 5, and 7].
- 2) Connect lower horizontal extrusions [9 and 10] between vertical assemblies [1/2, 3/4, 5/6, and 7/8], see Top View illustration for extrusion orientation.
- 3) Attach door threshold between vertical extrusions [5 and 7].
- 4) Attach door where indicated.
- 5) Slide Lower L-extrusions into groove of extrusions where indicated. (Note: These actually should ship attached to verticals)
- 6) Connect middle horizontals [11 and 12] between vertical assemblies [1/2, 3/4, 5/6, and 7/8] and atop door.
- 7) Slide Upper L-extrusions into groove of extrusions where indicated. (Note: These actually should ship attached to verticals)
- 8) Attach remaining horizontal extrusions [9 and 10] between vertical assemblies [1/2, 3/4, 5/6, and 7/8].

Top View Illustration

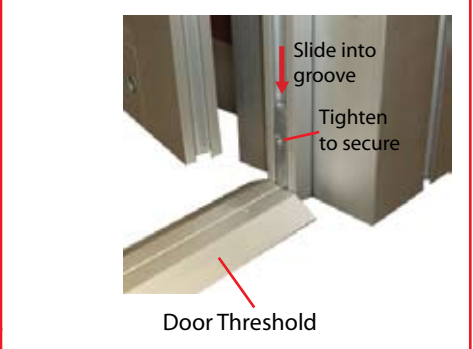
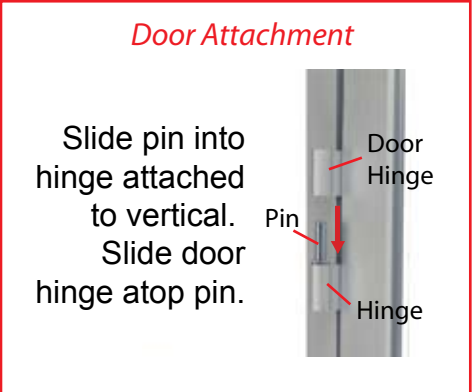
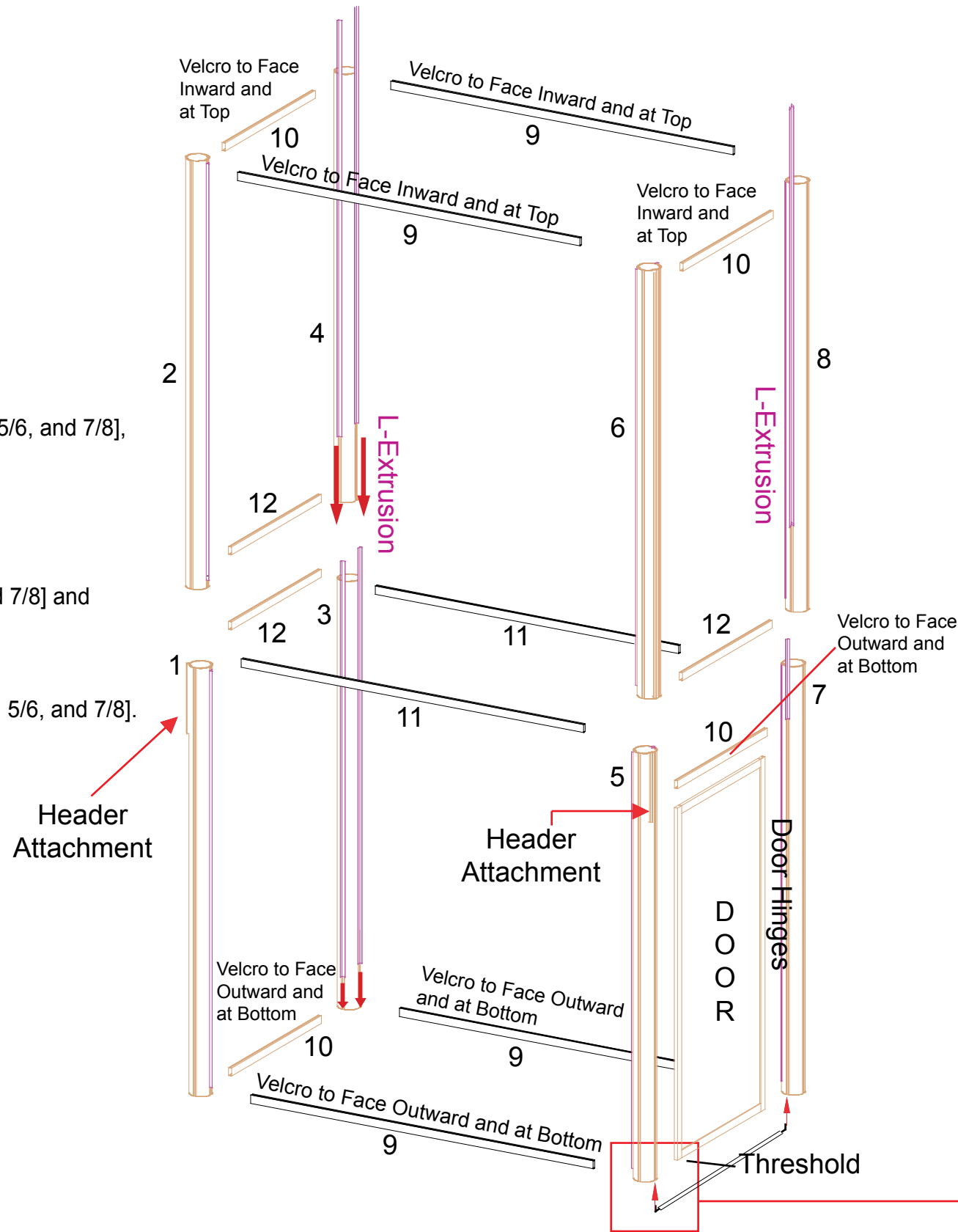
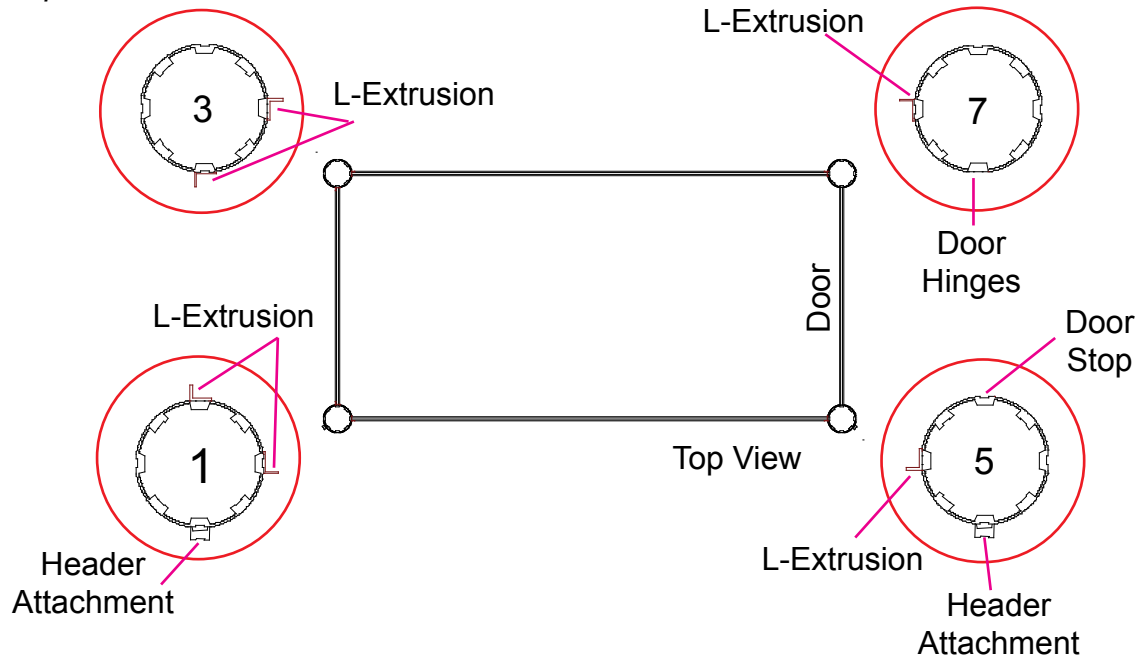

WHEN DISASSEMBLING ALUMINUM EXTRUSION, TIGHTEN ALL SETSCREWS AND LOCKS TO PREVENT LOSS DURING SHIPPING

Note: Attaching Graphics

Start at TOP of Graphic and Tower by wrapping the TOP portion of Graphic around extrusion and attach to Velcro located on BACK of TOP extrusion.

Attach the remaining 3 sides of the Graphics to Tower by applying Velcro on BACK of Graphic to Velcro on FRONT of Tower as shown.

Repeat for all 4 sides.

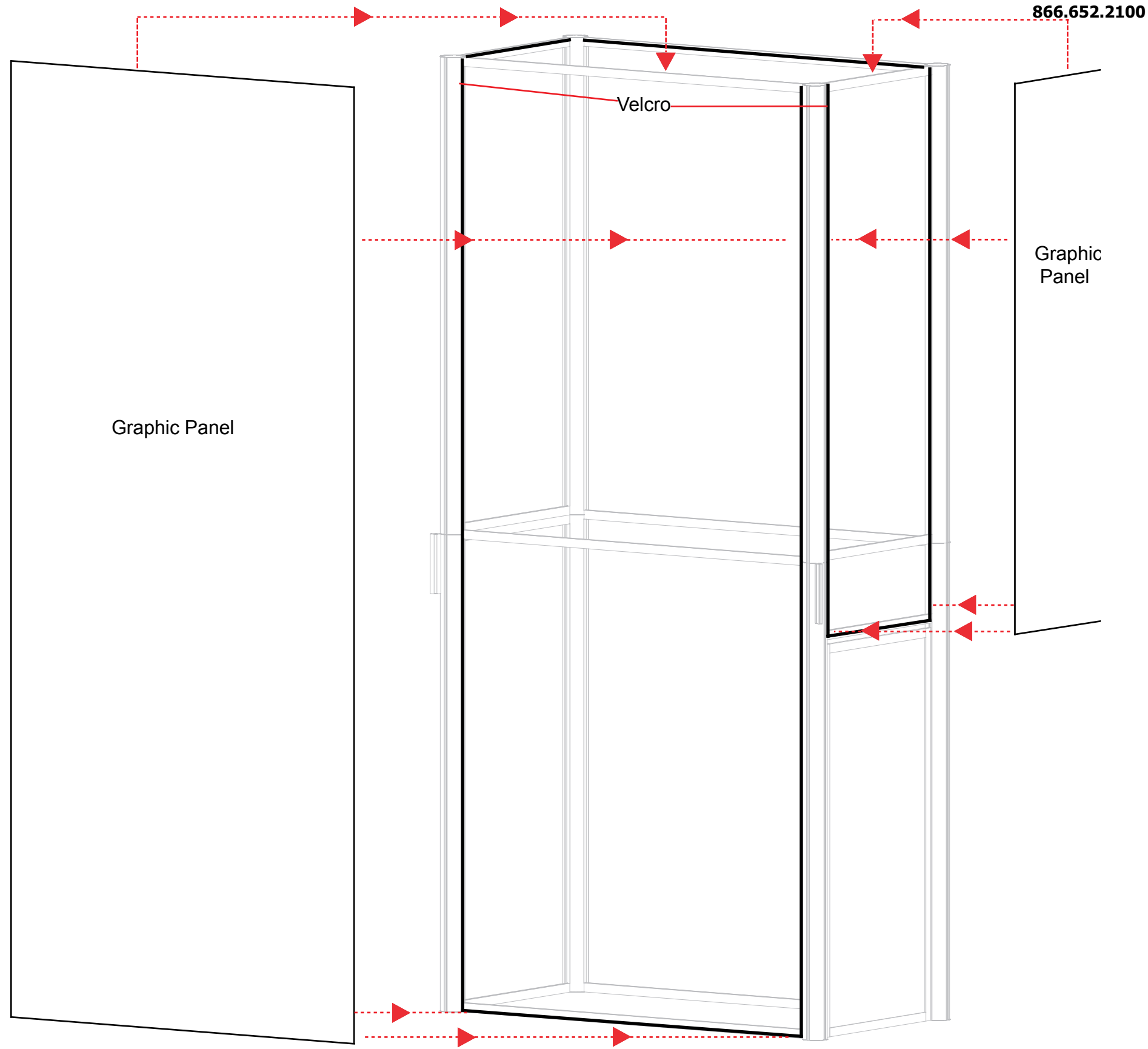
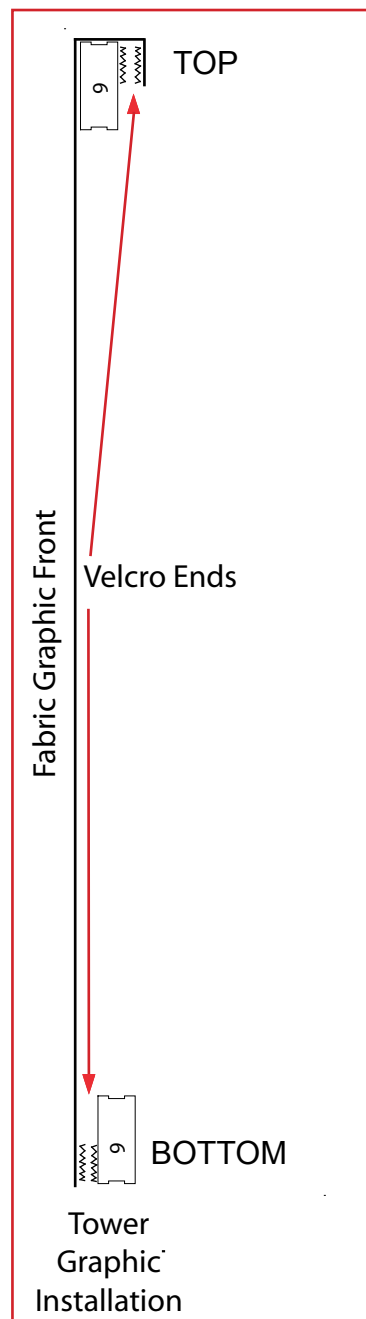

WHEN DISASSEMBLING ALUMINUM EXTRUSION, TIGHTEN ALL SETSCREWS AND LOCKS TO PREVENT LOSS DURING SHIPPING

866.652.2100

Part Number	Qty	Description
13	2	16.25" x 43.612" Graphic Support Assembly
14	2	16.25" x 88.612" Graphic Support Assembly
15	2	4.25" x 43.612" Graphic Support Assembly
16	2	4.25" x 88.612" Graphic Support Assembly

Standoff Graphic Supports

Supports should ship assembled, if for some reason they get separated assemble as shown connecting like numbers together.

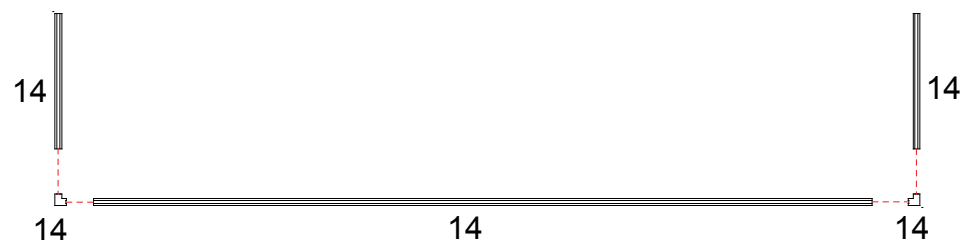

Keep Assembled

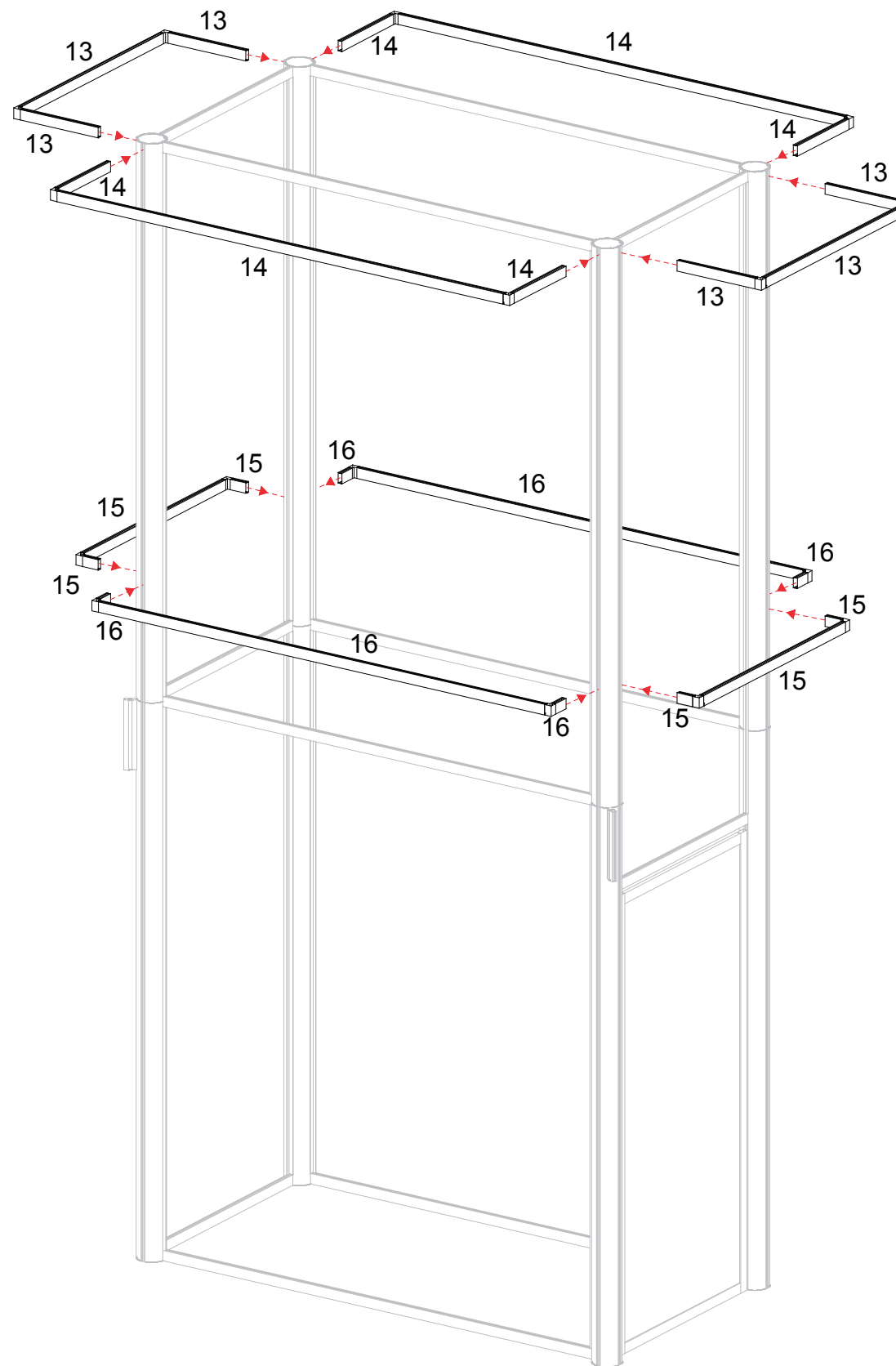

WHEN DISASSEMBLING ALUMINUM EXTRUSION, TIGHTEN ALL SETSCREWS AND LOCKS TO PREVENT LOSS DURING SHIPPING

Note: Attaching Graphics

Attach Standoff Graphics to Velcro by wrapping the Graphic over the Top of the Upper Horizontals and under the Bottom of the Lower Horizontals. Repeat for all 4 Graphics.

Lower extrusion assembly is adjustable, this may move up or down to achieve desired tension in Graphics. Refer back to previous setup page and General info page for instructions on adjusting assembly.

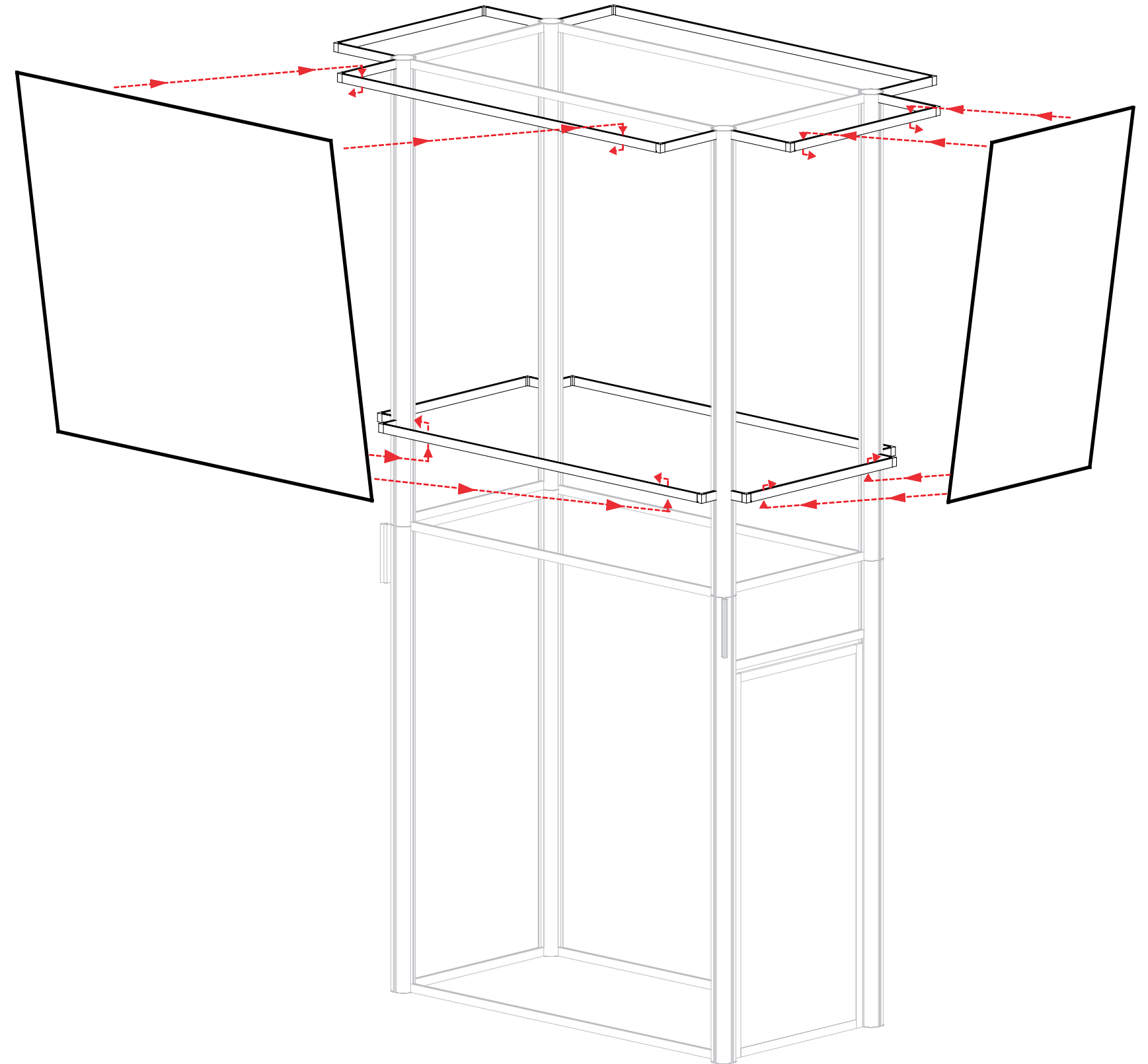
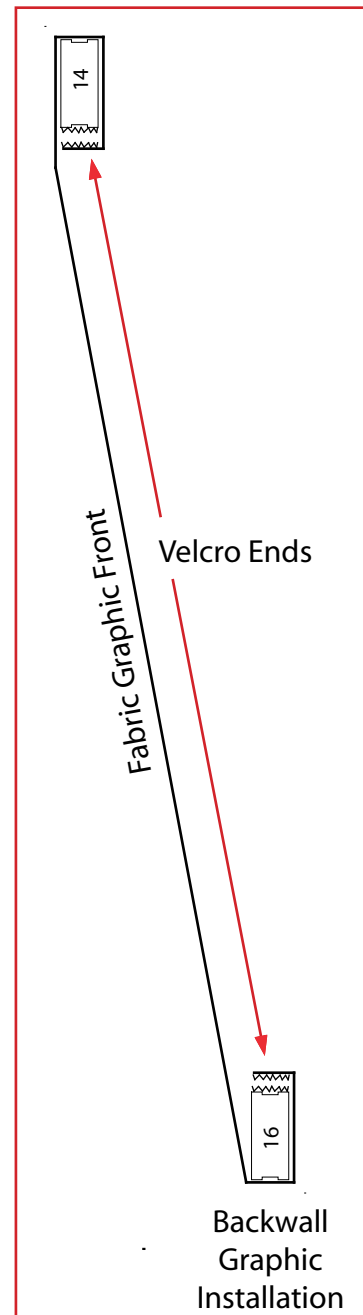

WHEN DISASSEMBLING ALUMINUM EXTRUSION, TIGHTEN ALL SETSCREWS AND LOCKS TO PREVENT LOSS DURING SHIPPING

Part Number	Qty for Step	Description
17	1	18"D Round Base Plate
18	1	95"h Round Vertical Extrusion
19	1	36"h Round Vertical Extrusion

Repeat Steps for All 4 Workstations.
 (Note: Workstations should ship assembled.)

Steps

- 1) Attach vertical extrusions [18 and 19] to base plate [17] as shown.
- 2) Attach tapered plex wings to front of vertical extrusion [19] and round signs to vertical extrusion [18].
- 3) Place and attach counter atop vertical extrusion [19].

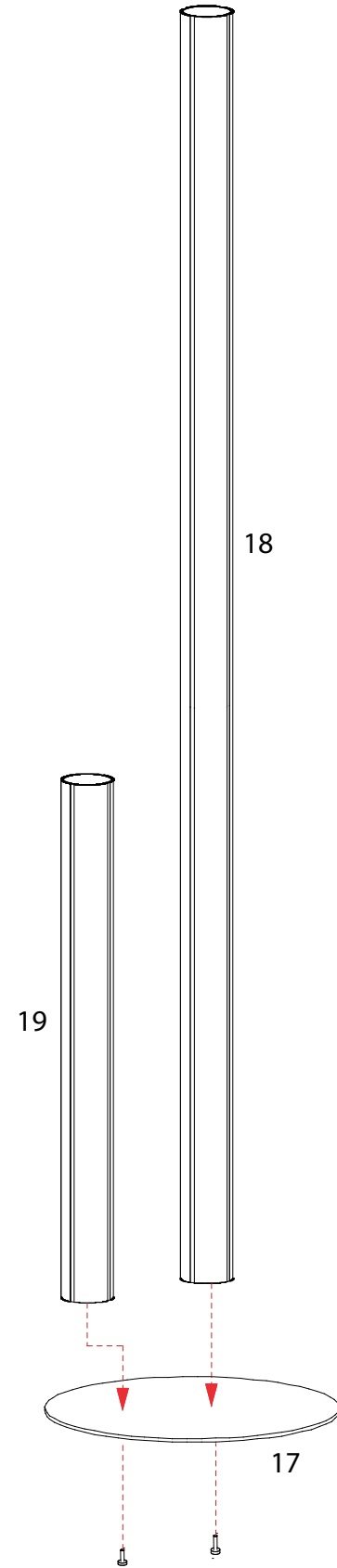

Sign Attachment



Slide stand off barrels to groove of backwall extrusion

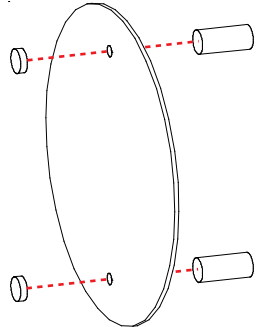

Secure Sign to stand off barrels using stand off caps

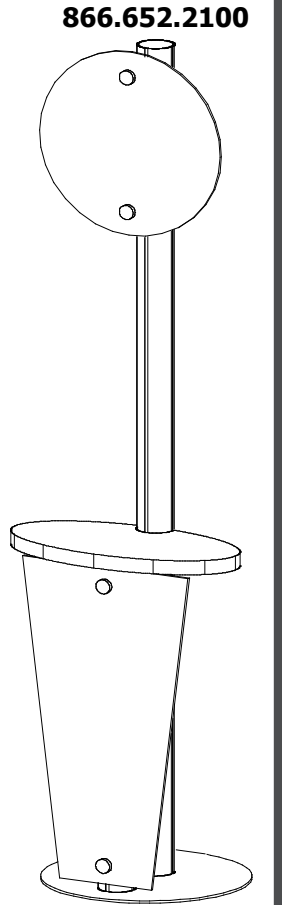
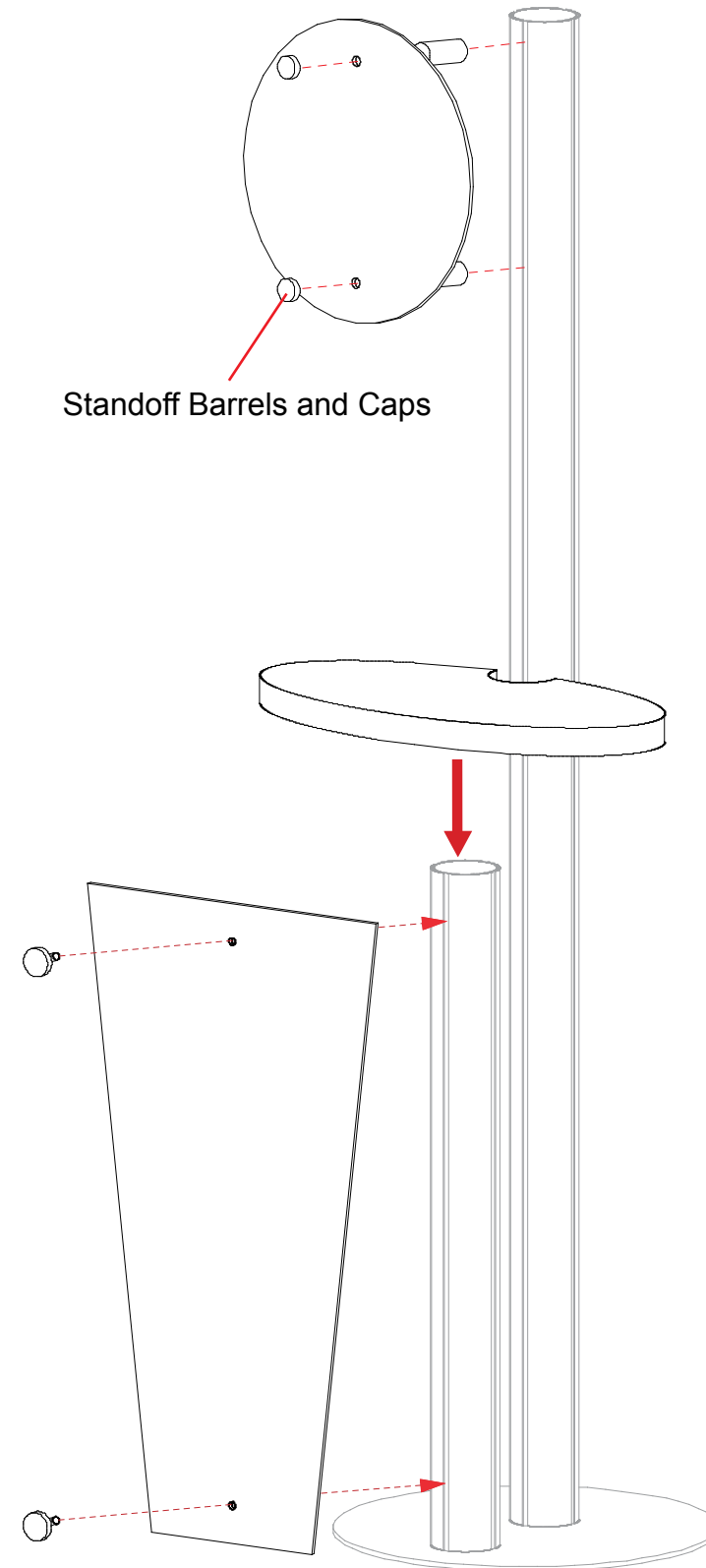

WHEN DISASSEMBLING ALUMINUM EXTRUSION, TIGHTEN ALL SETSCREWS AND LOCKS TO PREVENT LOSS DURING SHIPPING

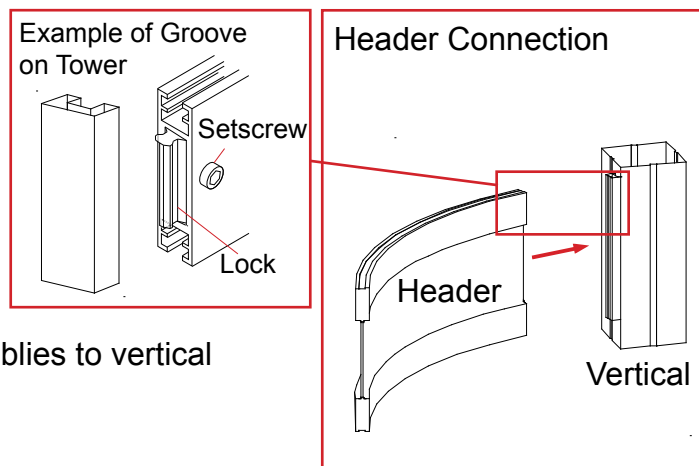

Attach Header Assemblies to vertical extrusions as shown.

Keep Headers Assembled for Shipping

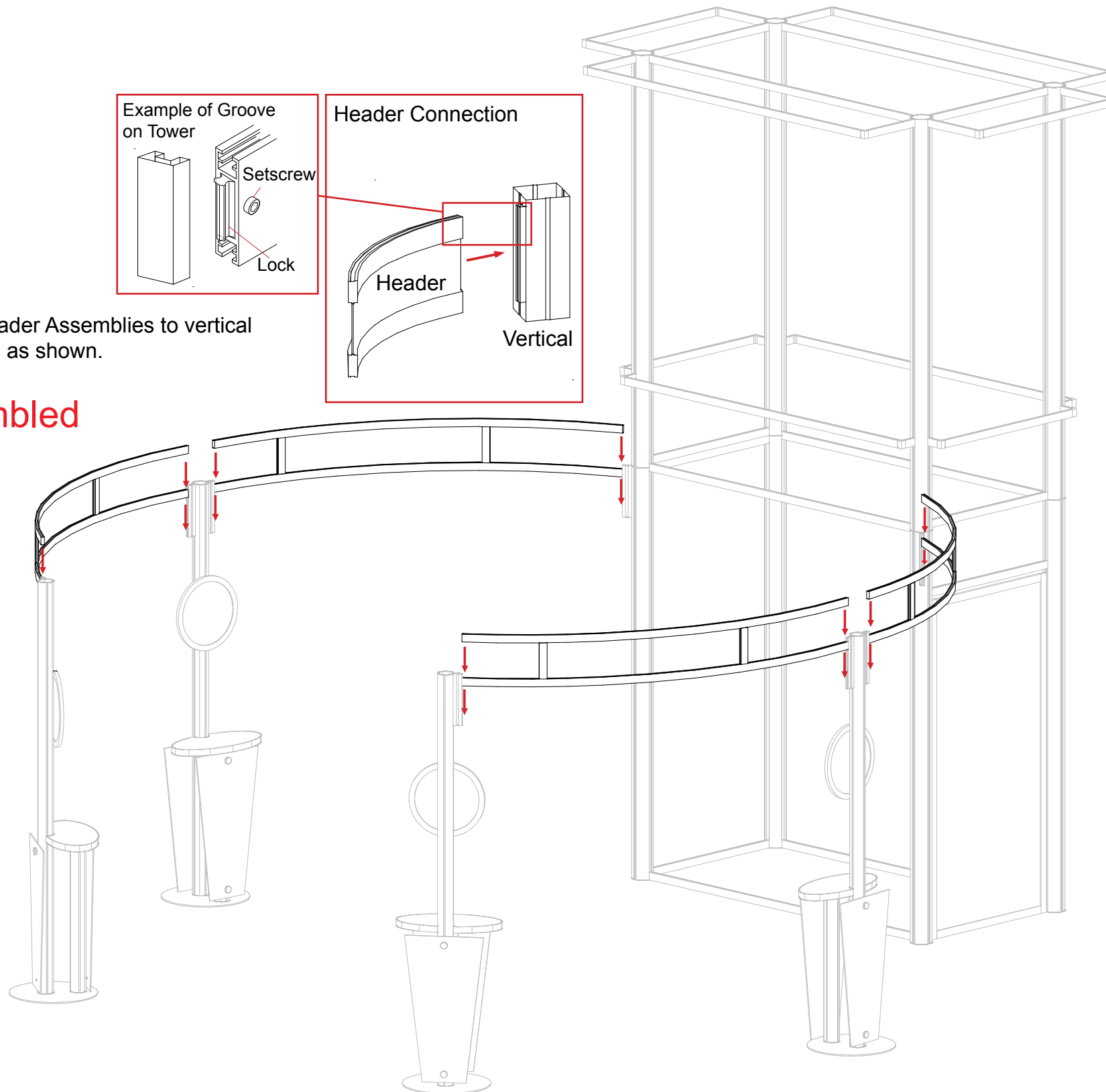

WHEN DISASSEMBLING ALUMINUM EXTRUSION, TIGHTEN ALL SETSCREWS AND LOCKS TO PREVENT LOSS DURING SHIPPING

866.652.2100

Item	Qty.	Description
20	1	38" h Vertical Extrusion
21	1	38" h Vertical Extrusion
22	1	38" h Vertical Extrusion
23	1	38" h Vertical Extrusion w/ Door Hinges
24	1	38" h Vertical Extrusion w/ Door Stop
25	1	38" h Vertical Extrusion w/ Door Hinges
26	4	16.5" Curved Horizontal Extrusion
27	4	11.5" Horizontal Extrusion
28	4	22.95" Curved Horizontal Extrusion

Steps:

- 1) Attach lower horizontal extrusions [26, 27 and 28] between vertical extrusions [20, 21, 22, 23, 24, and 25].
- 2) Place inserts and attach doors where indicated.
- 3) Attach upper horizontal extrusions [26, 27 and 28] between vertical extrusions [20, 21, 22, 23, 24, and 25] and atop doors and inserts.
- 4) Velcro shelf supports to inside of assembled pedestal, then set internal shelves atop supports.
- 5) Place counter top on assembled pedestal.

Note: Keep ALL pieces highlighted in Orange together and ALL pieces highlighted in Light Brown together for shipping.

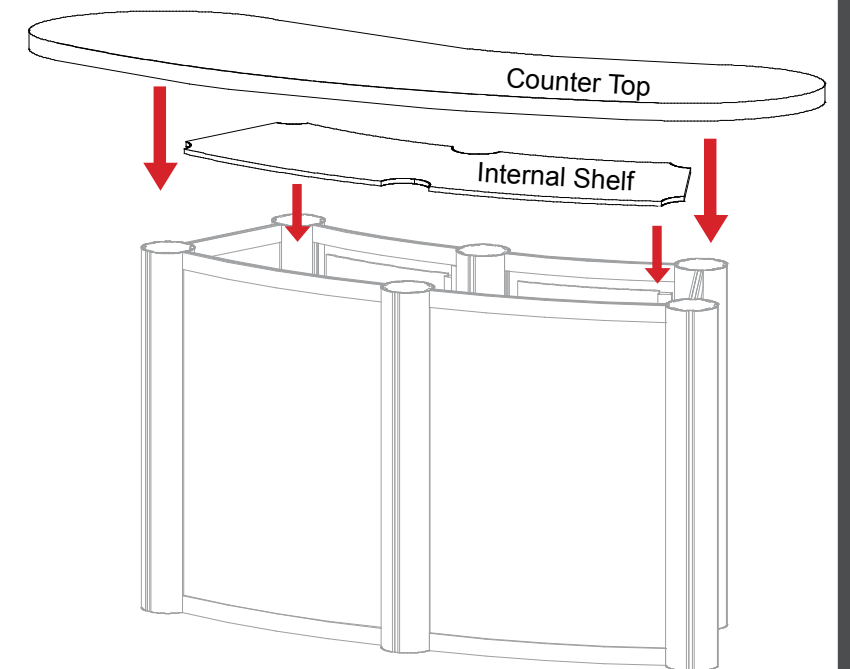
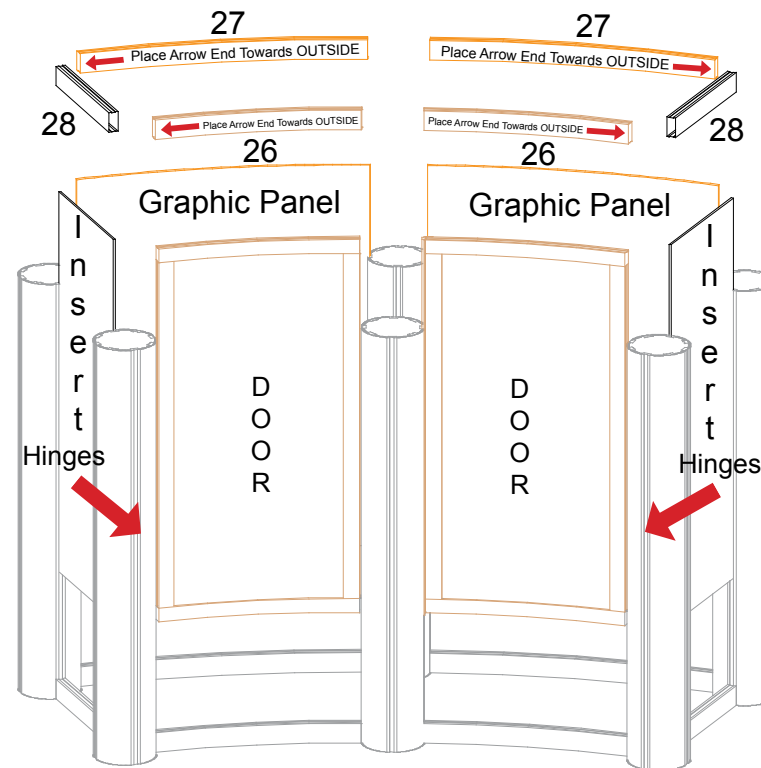
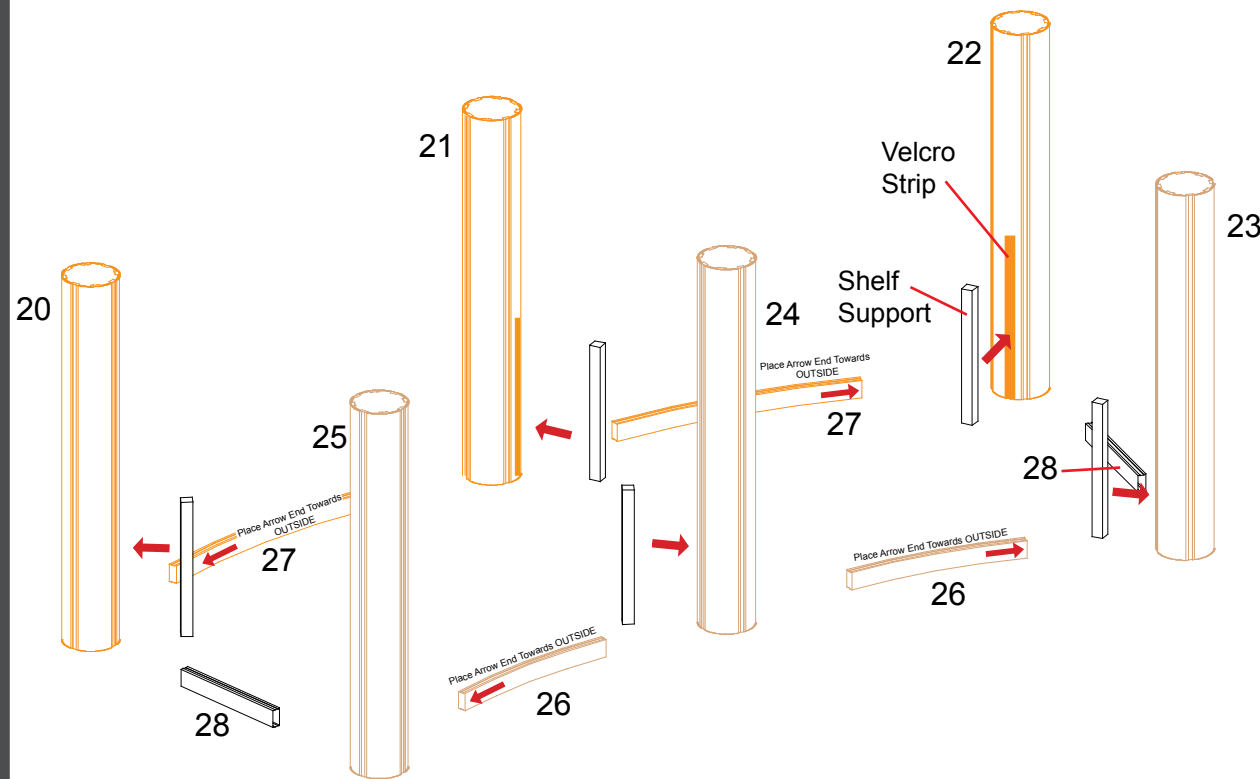
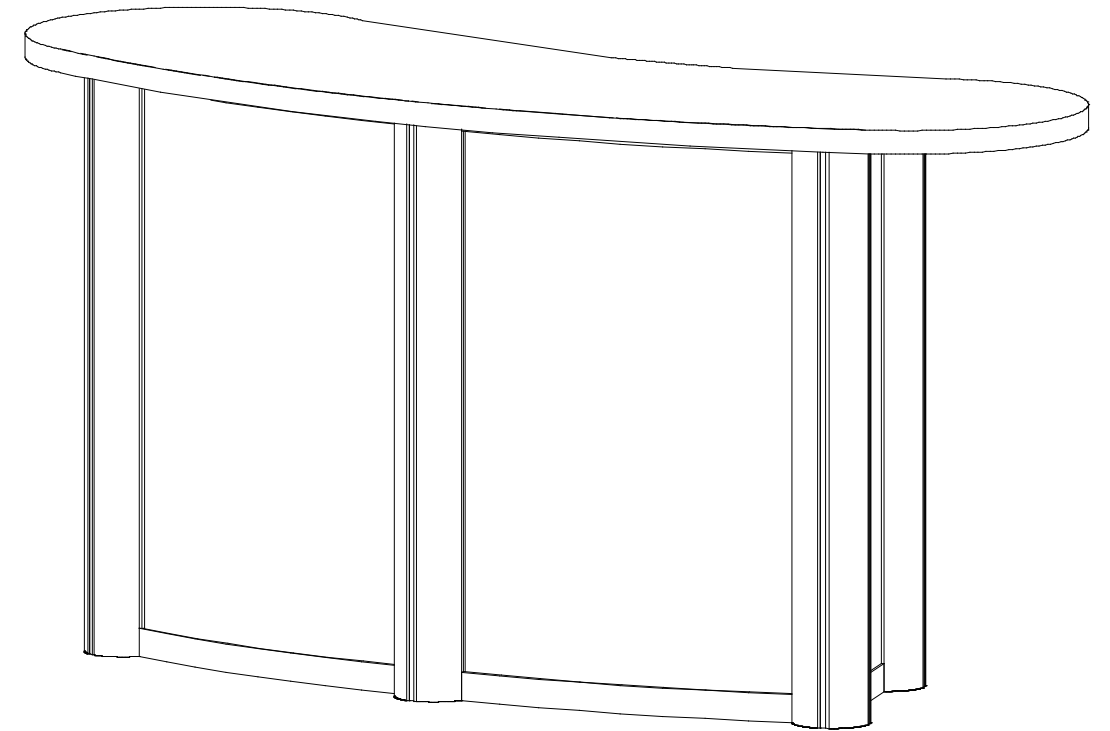
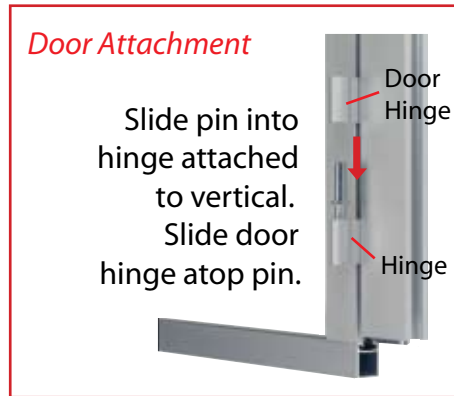

WHEN DISASSEMBLING ALUMINUM EXTRUSION, TIGHTEN ALL SETSCREWS AND LOCKS TO PREVENT LOSS DURING SHIPPING

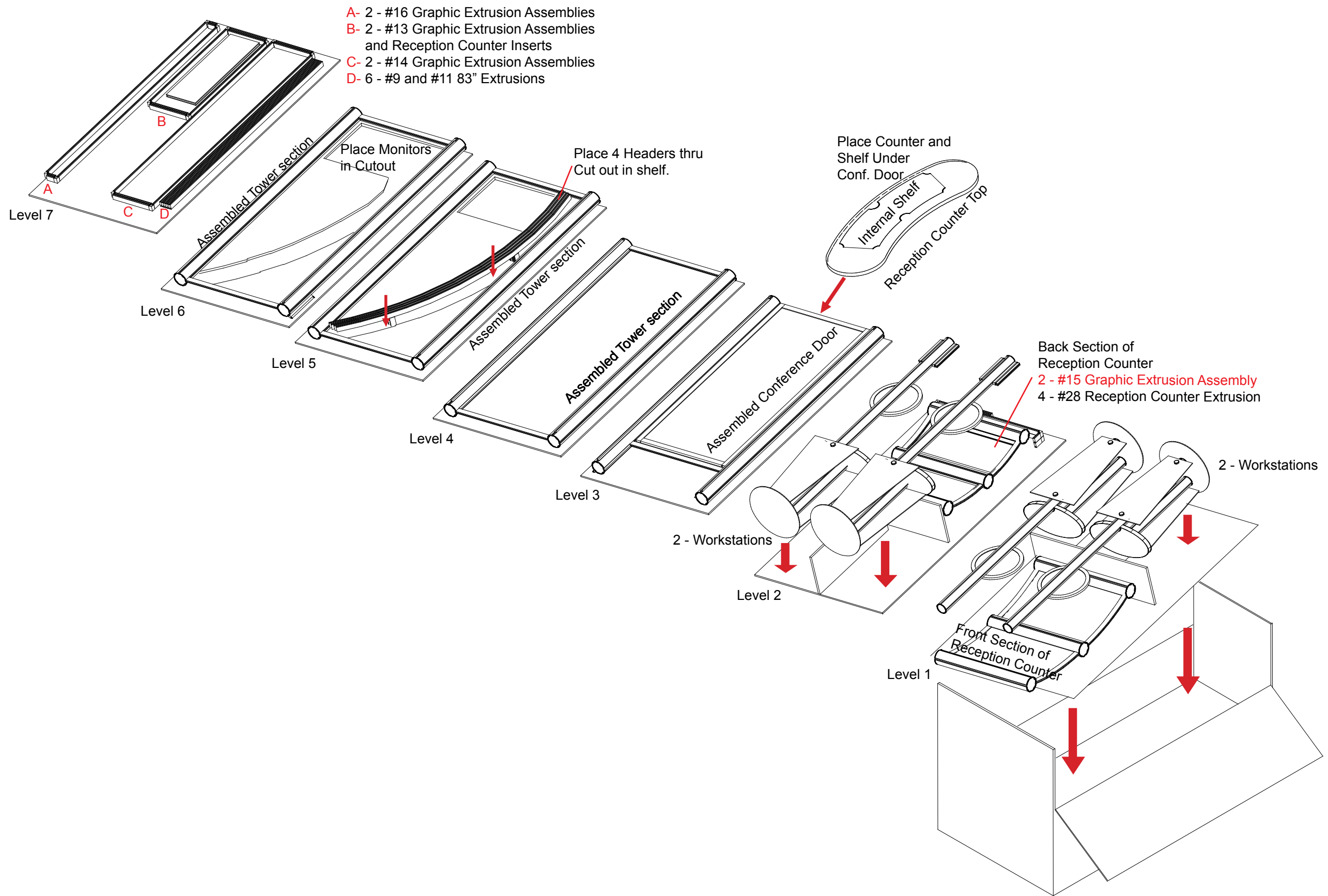

WHEN DISASSEMBLING ALUMINUM EXTRUSION, TIGHTEN ALL SETSCREWS AND LOCKS TO PREVENT LOSS DURING SHIPPING

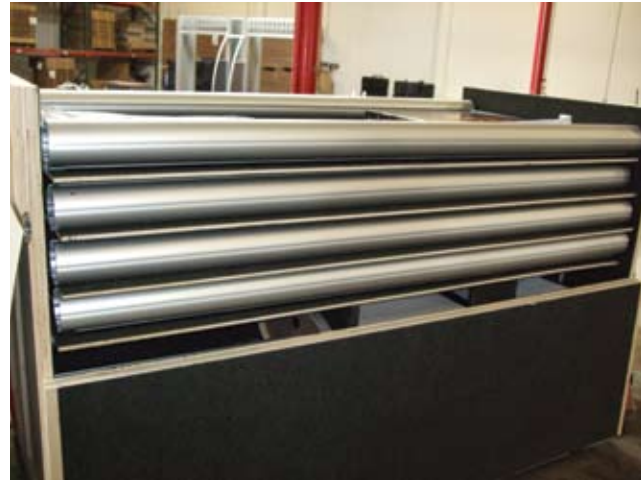

Side View of Crate

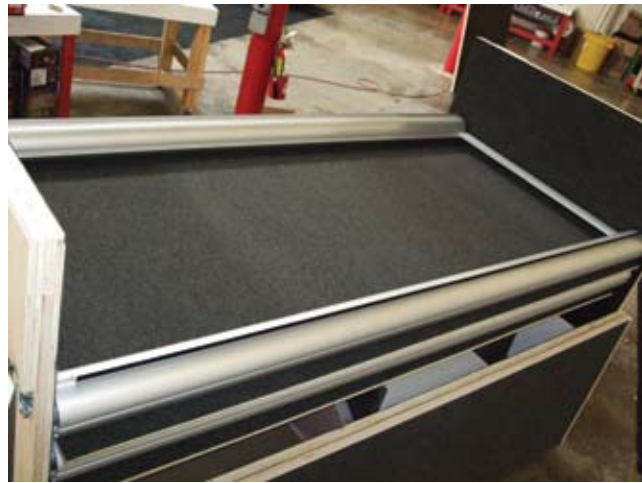

Level 4



Level 5

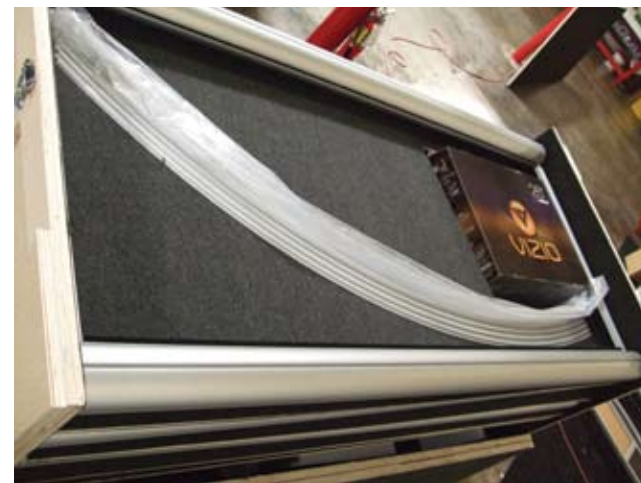

Level 6



Level 7



Level 1



Level 1



Level 2



Level 3

WHEN DISASSEMBLING ALUMINUM EXTRUSION, TIGHTEN ALL SETSCREWS AND LOCKS TO PREVENT LOSS DURING SHIPPING