

WHEN DISASSEMBLING ALUMINUM EXTRUSION, TIGHTEN ALL SETSCREWS AND LOCKS TO PREVENT LOSS DURING SHIPPING

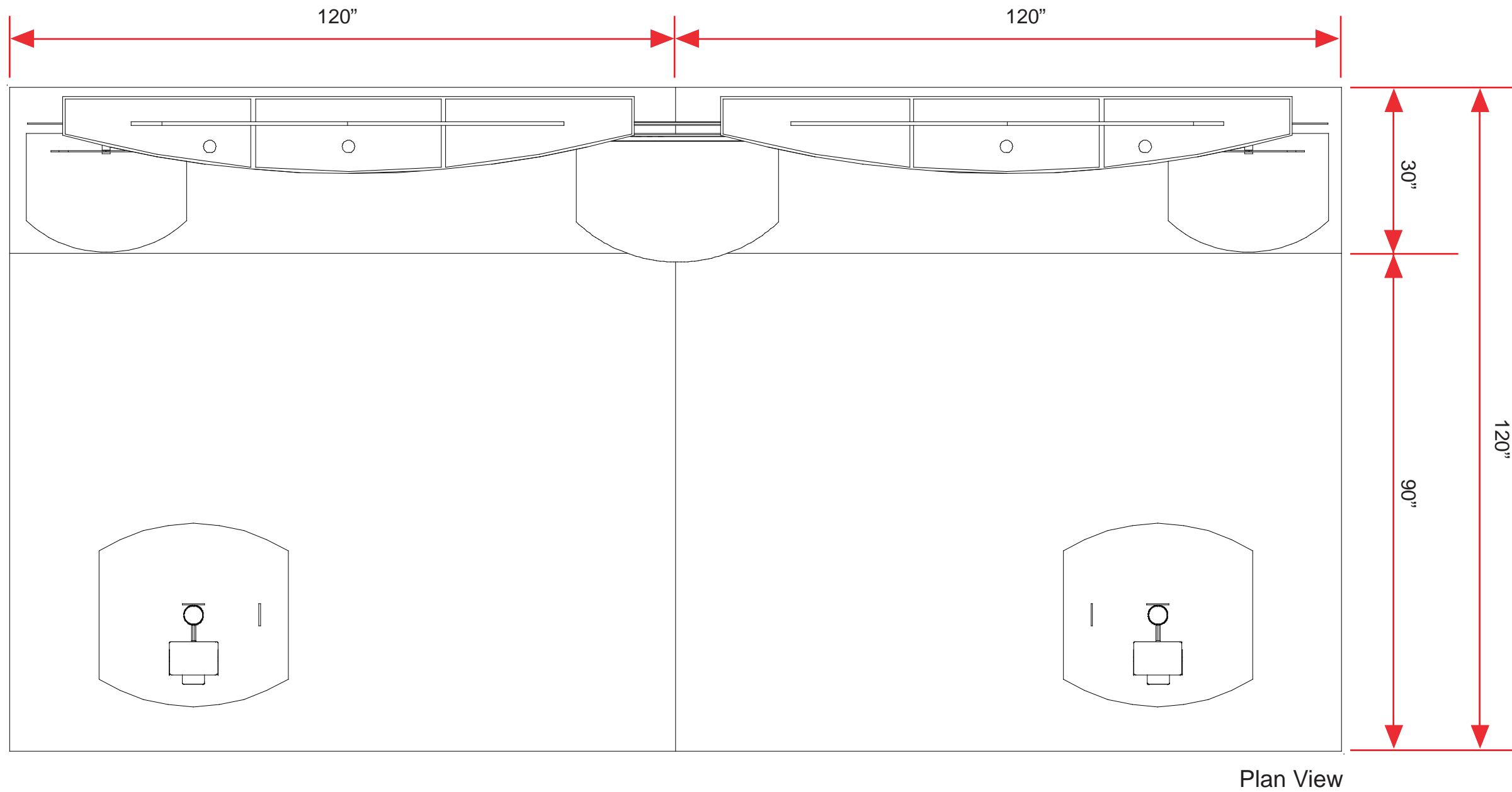

WHEN DISASSEMBLING ALUMINUM EXTRUSION, TIGHTEN ALL SETSCREWS AND LOCKS TO PREVENT LOSS DURING SHIPPING

visionary™ DESIGNS

Using Your Setup Instructions

The Visionary Designs Setup Instructions are created specifically for your configuration. They are laid out sequentially, including an exploded view of the entire display, and then a logical series of detailed steps to assemble the main structure and components. We encourage you to study the instructions **before** attempting to assemble your exhibit.

Each page reminds you to tighten the setscrews after disassembling your exhibit to prevent loss of the locks and setscrews (see below in RED). This is **VERY IMPORTANT**.

Cleaning and Packing Your Display

- 1) Use care when cleaning aluminum extrusion or acrylic inserts. Use only non-abrasive cleaners.
- 2) When cleaning laminate inserts or countertops, use mild cleansers and a soft material such as cotton.
- 3) Keep all display components away from extreme heat and long exposure to sunlight to avoid warping and fading.
- 4) Retain all packing material. It will make re-packing much easier and will reduce the likelihood of shipping damage.



The Tool

Most Visionary Designs exhibits can be assembled with the supplied Hex Key Tool. Occasionally, a flat head screwdriver may be required.



Typical Connection

Most horizontal extrusion connections have a patented expandable lock. This lock inserts into the groove of an opposing extrusion. Tightening the lock with the Hex Key Tool expands the lock and creates a strong positive connection.



Typical Connection (cont'd)

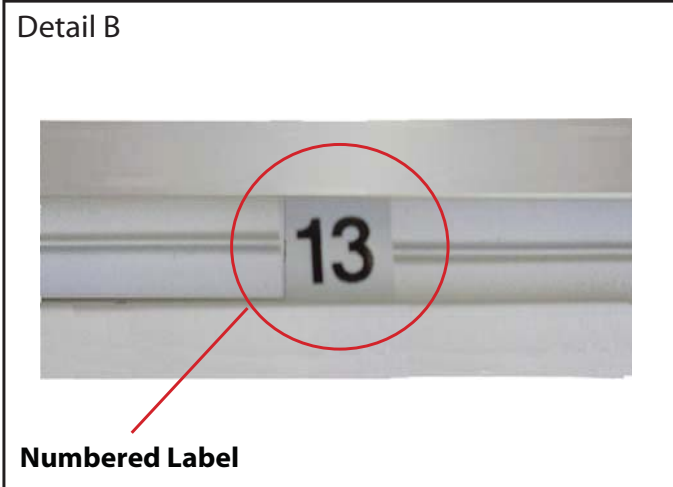

Numbered Label

Each extrusion contains a numbered label which corresponds with setup instructions. The label is located within a groove of the extrusion (when possible). With Visionary Designs the labels contain Black numbers unless otherwise specified.



Horizontal Inline Connection (remove only one setscrew)

Remove only (1) setscrew when disassembling. Replace setscrew in extrusion after assembling it. Before packing, replace setscrew in extrusion to avoid losing it.

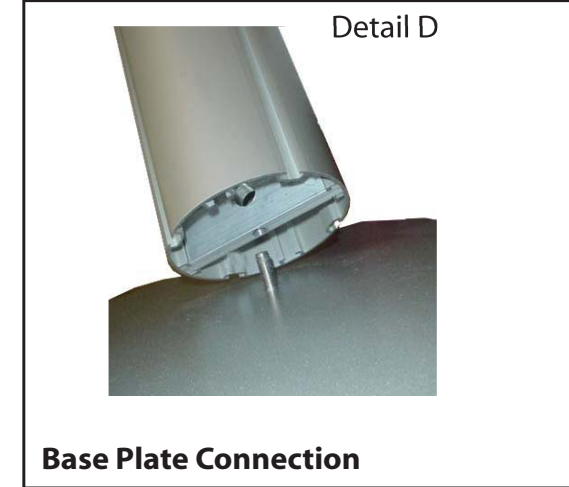

Base Plate Connection

Attach base plate to round or square vertical extrusion using the bolt provided. Be careful not to strip the threads.

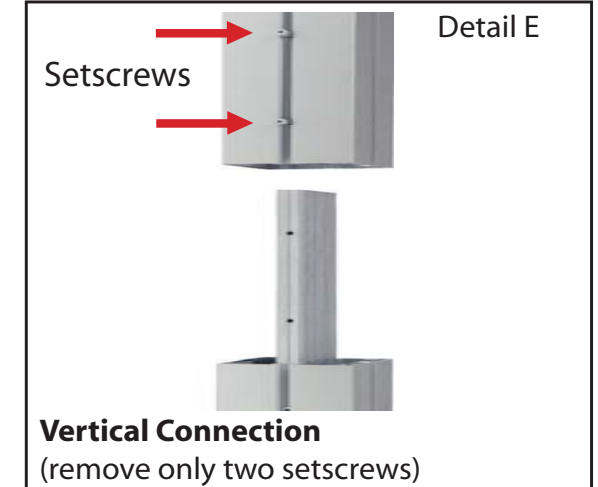

Vertical Connection
(remove only two setscrews)

When vertical extrusions are packed in portable cases rather than crates or tubs, they must be broken down into smaller sections which then require assembly.

Remove only (2) setscrews when disassembling. Replace setscrews in extrusion after assembling it. Before packing, replace setscrews in extrusion to avoid losing them.

WHEN DISASSEMBLING ALUMINUM EXTRUSION, TIGHTEN ALL SETSCREWS AND LOCKS TO PREVENT LOSS DURING SHIPPING

866.652.2100

Item	Qty	Description
1	1	81" h Round Vertical Extrusion
2	1	81" h Square Vertical Extrusion
3	1	81" h Square Vertical Extrusion
4	1	81" h Round Vertical Extrusion
5	2	83.58" w Horizontal Extrusion
6	2	83.58" w Horizontal Extrusion
7	1	28" w Horizontal Extrusion
8	1	28" w Horizontal Extrusion
9	1	38" h Extrusions w/ 135° Vertical Extrusion w/ Door Stop
10	1	38" h Extrusions w/ 135° Vertical Extrusion w/ Door Hinge
11	4	12.5" w Horizontal Extrusion
12	2	Curved Horizontal Extrusion

Steps

- 1) Attach horizontal extrusions [5, 6, 7 and 8] between vertical extrusions [1, 2, 3 and 4] as shown.
- 2) Attach horizontal extrusions [11] between vertical extrusions [2&9 and 3&10], placing inserts where indicated.
- 3) Attach curve horizontal extrusions [12] between vertical extrusions [9 and 10], then attach door between horizontal extrusions.
- 4) Velcro shelf supports to inside of assembled base, then set internal shelf atop supports.
- 5) Place counter atop assembled pedestal.
- 6) Apply graphics to assembled backwall, see Graphic Attachment details.

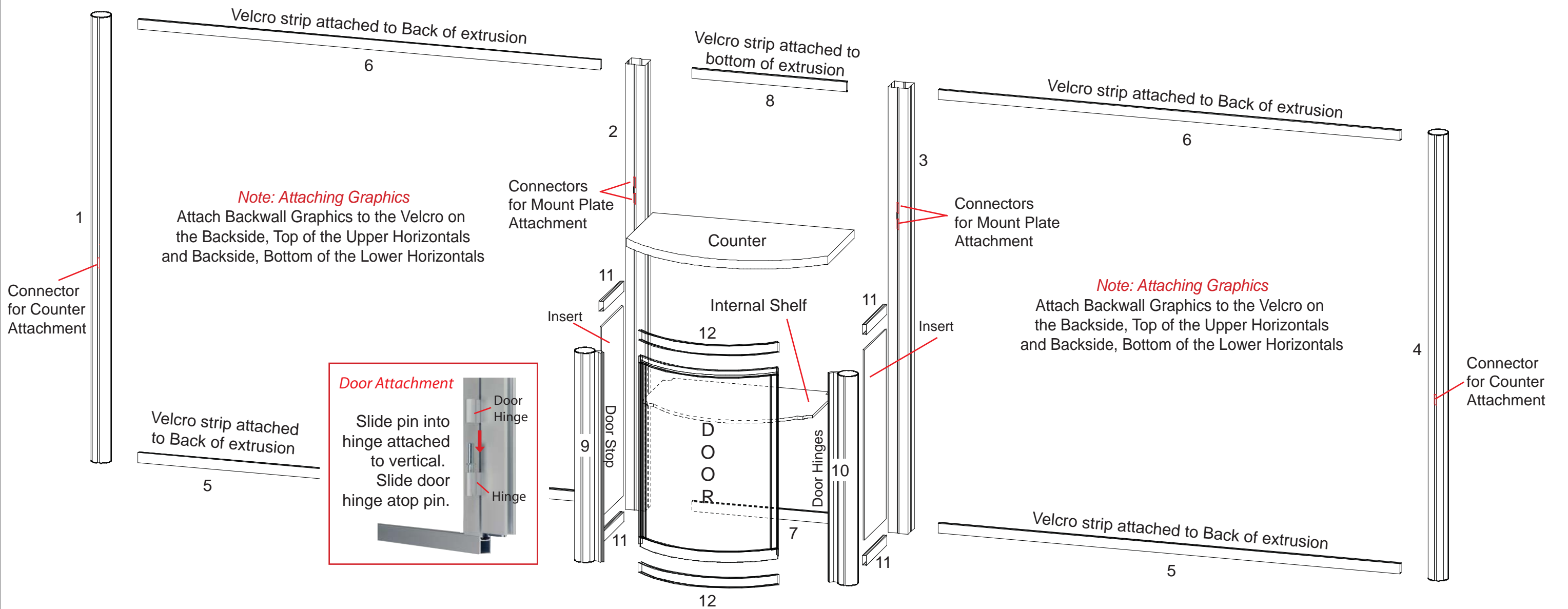

WHEN DISASSEMBLING ALUMINUM EXTRUSION, TIGHTEN ALL SETSCREWS AND LOCKS TO PREVENT LOSS DURING SHIPPING

866.652.2100

Item	Qty.	Description
13	1	Aluminum Plate for Monitor Mount Attachment
14	2	78" w Horizontal Extrusion
15	2	2.453" w Vertical Extrusion
16	2	2.453" w Vertical Extrusion
17	2	80.638" w Formed Horizontal Extrusion

- Steps**
- 1) Attach horizontal extrusion [14] to top of ceiling using bolts and wing nuts.
 - 2) Connect vertical extrusions [15 and 16] to left and right side of horizontal extrusion [14]. Place Insert.
 - 3) Attach curved horizontal extrusion [17] atop vertical extrusions [15 and 16].
 - 4) Repeat steps 1-3 for additional ceiling.
 - 5) Attach assembled ceiling to top of assembled backwall as shown.
 - 6) Attach aluminum plate [13] to connectors on vertical extrusions [2 and 3].
 - 7) Attach header, wings and monitor mount to backwall where indicated.

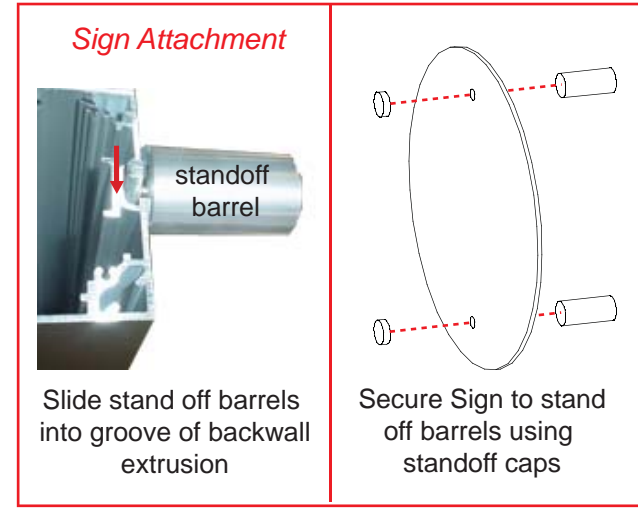
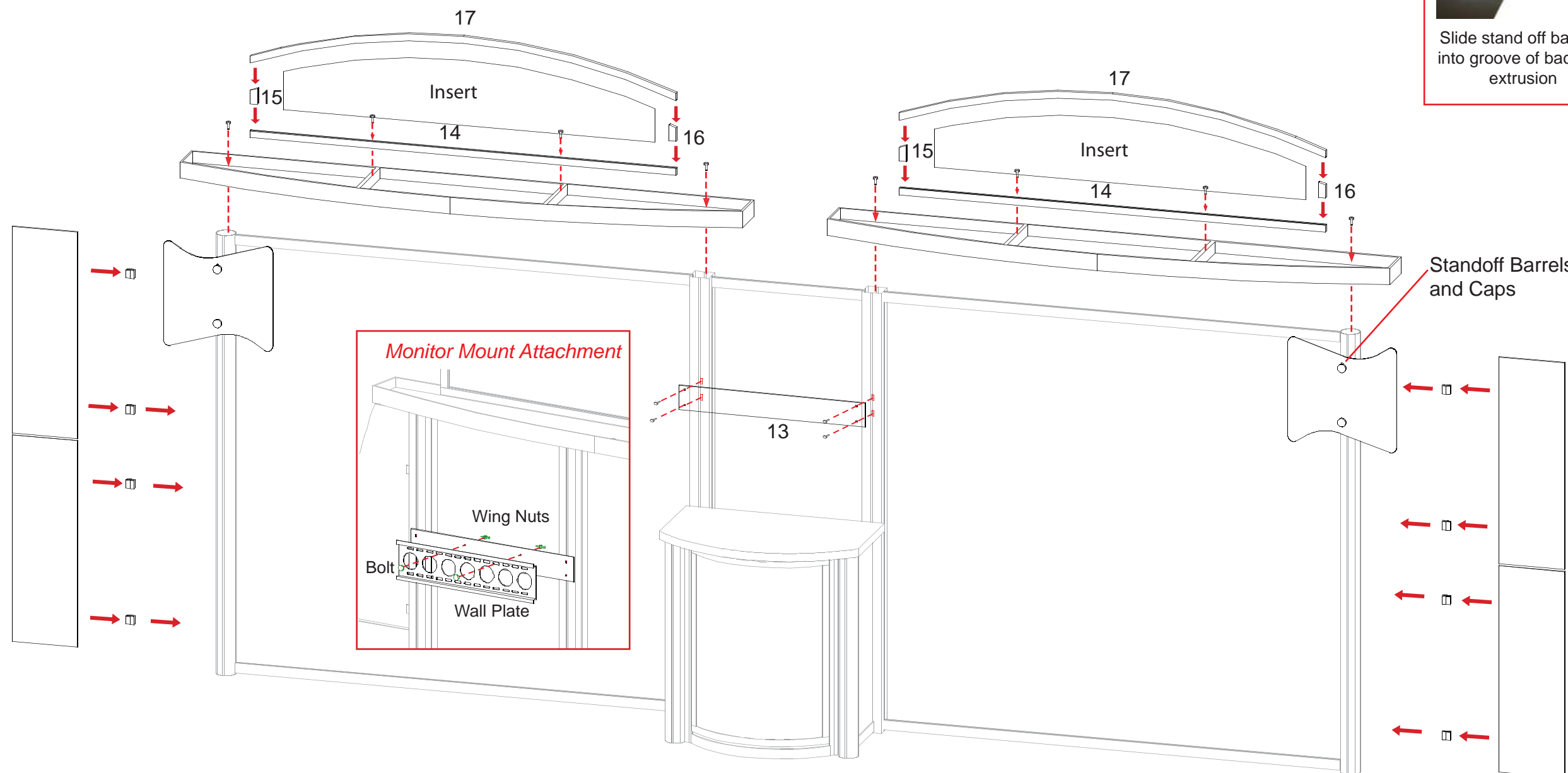

WHEN DISASSEMBLING ALUMINUM EXTRUSION, TIGHTEN ALL SETSCREWS AND LOCKS TO PREVENT LOSS DURING SHIPPING

866.652.2100

Item	Qty.	Description
13	1	Aluminum Plate for Monitor Mount Attachment
14	1	78" w Horizontal Extrusion
15	1	2.453" w Vertical Extrusion
16	1	2.453" w Vertical Extrusion
17	1	80.638" w Formed Horizontal Extrusion

- Steps**
- 1) Attach ceilings to top of assembled backwall as shown.
 - 2) Attach horizontal extrusion [14] to top of ceilings where indicted using bolts and wing nuts.
 - 3) Connect vertical extrusions [15 and 16] to left and right side of horizontal extrusion [14]. Place Insert.
 - 4) Attach curved horizontal extrusion [17] atop vertical extrusions [15 and 16].
 - 6) Attach aluminum plate [13] to connectors on vertical extrusions [2 and 3].
 - 7) Attach wings and monitor mount to backwall where indicated.

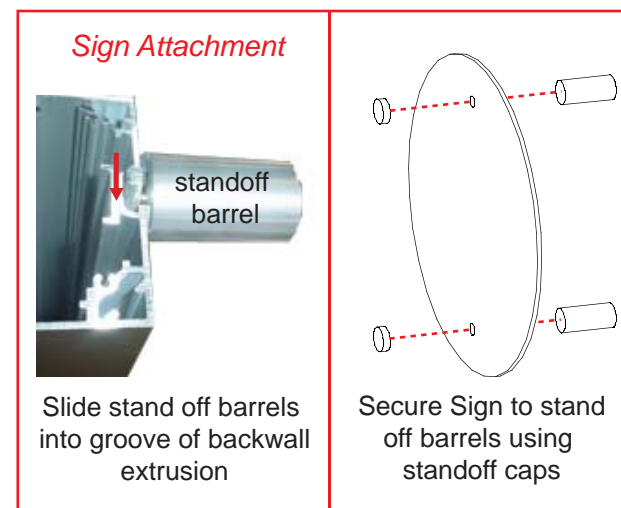
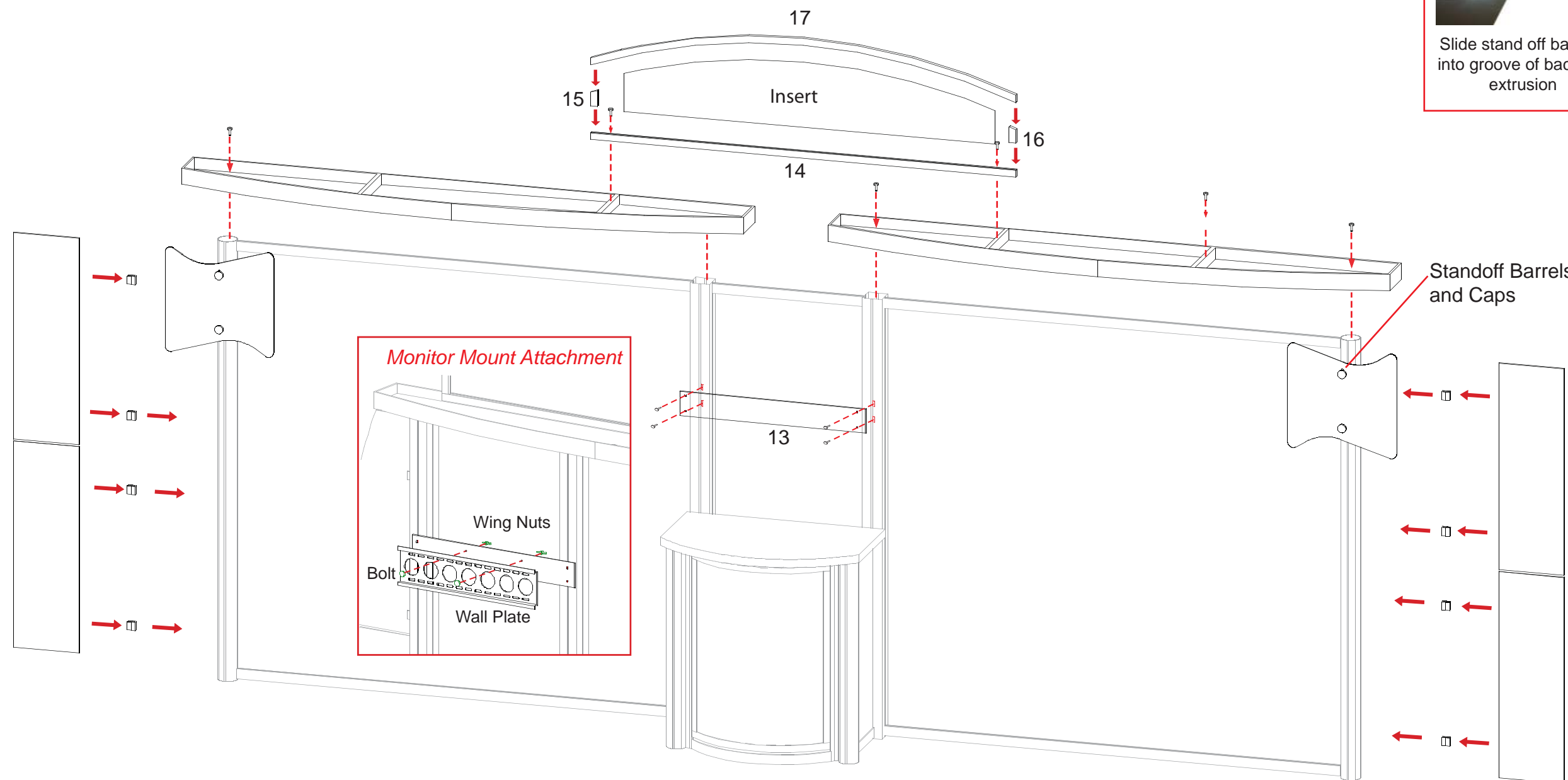

WHEN DISASSEMBLING ALUMINUM EXTRUSION, TIGHTEN ALL SETSCREWS AND LOCKS TO PREVENT LOSS DURING SHIPPING

866.652.2100

Item	Qty.	Description
18	1	38" h Round Vertical Extrusion w/ 135° Connector Attached
19	1	38" h Round Vertical Extrusion
20	1	38" h Round Vertical Extrusion
21	1	38" h Round Vertical Extrusion
22	4	8.25" w Horizontal Extrusion
23/23A	1/1	20.433" w Horizontal Extrusion
24	2	19.8834" w Curved Horizontal Extrusion

Steps

- 1) Connect lower horizontal extrusions [22, 23 and 24] between vertical extrusions as shown.
- 2) Place inserts and attach door where indicated, see Door Attachment details.
- 3) Connect upper horizontal extrusions [22, 23 and 24] between vertical extrusions and atop inserts and door.
- 4) Velcro shelf supports to inside of assembled base.
- 5) Set internal shelf atop supports.
- 6) Set counter atop assembled pedestal.

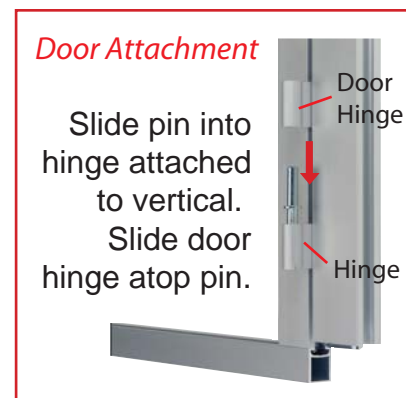
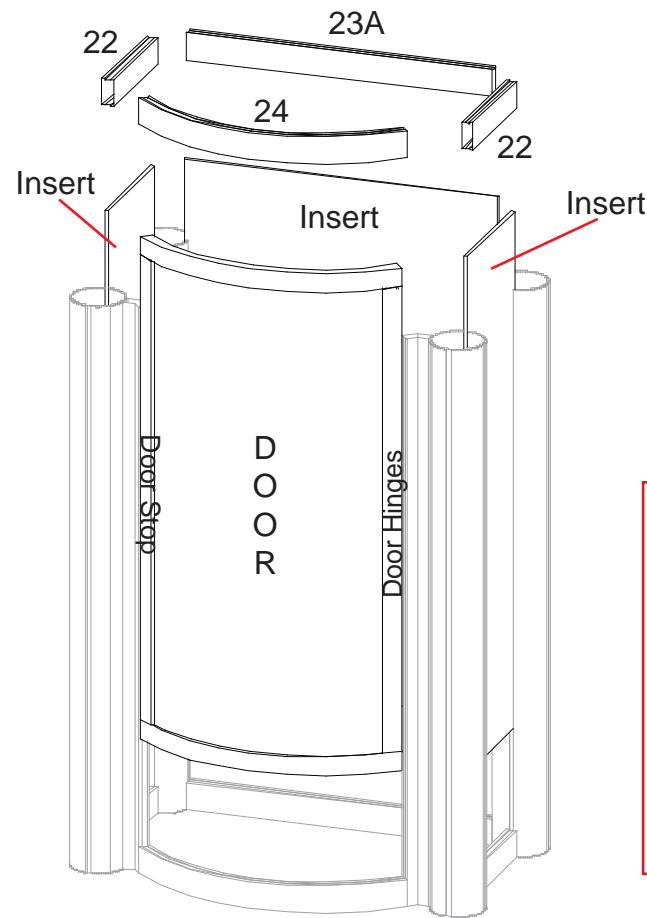
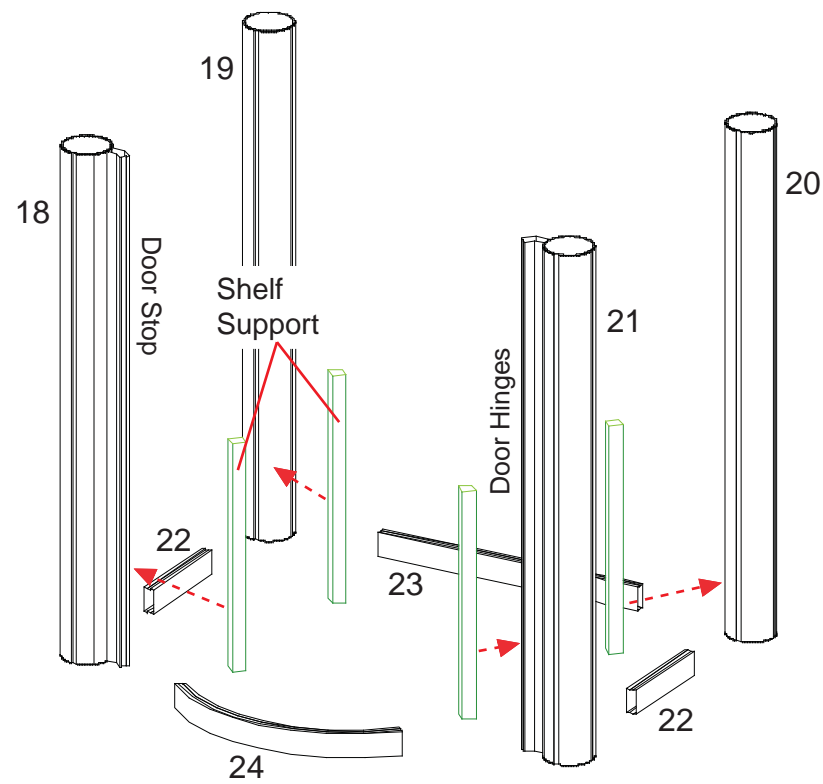

* Secure counter top to vertical by inserting screw thru metal and counter top and inserting into connector located in vertical.

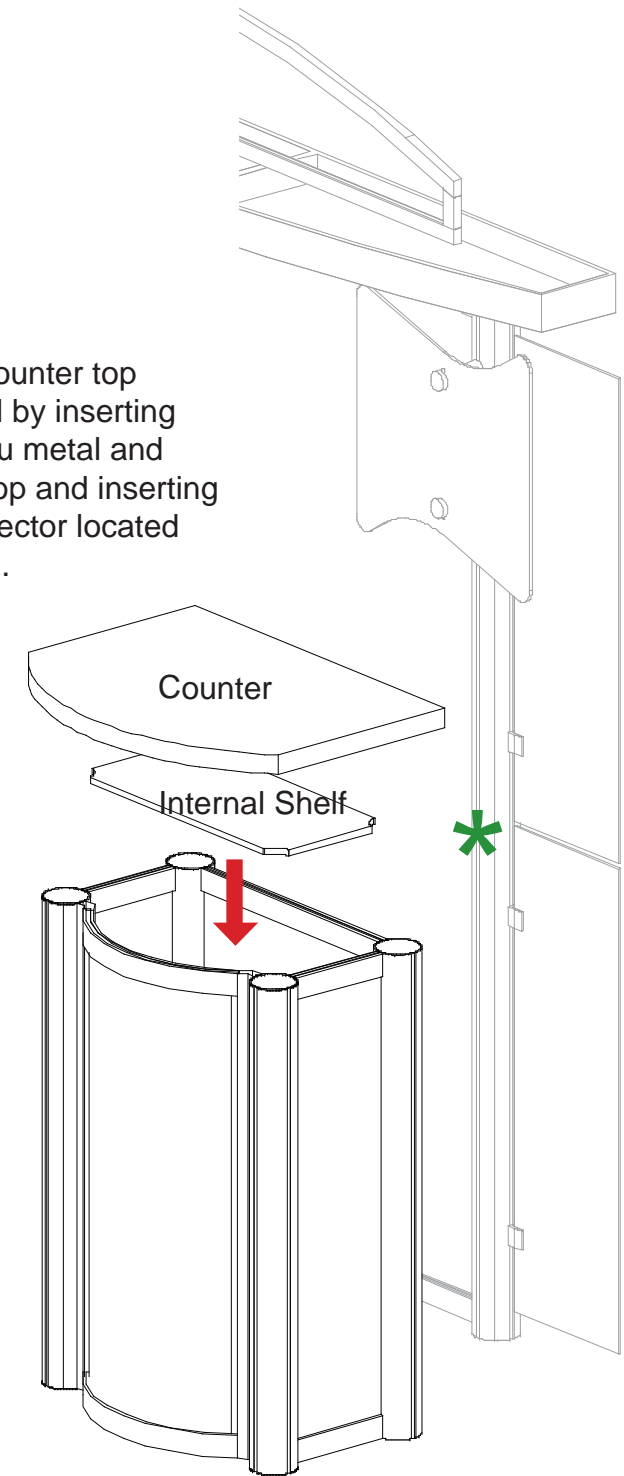

WHEN DISASSEMBLING ALUMINUM EXTRUSION, TIGHTEN ALL SETSCREWS AND LOCKS TO PREVENT LOSS DURING SHIPPING

Workstation Base:

Item	Description
1	19" w x 38" h Door Panel
2	38" h 90° Connector
3	30" w x 38" h Flat Panel
4	38" h 90° Connector
5	19" w x 38" h Door Panel
6	38" h 90° Connector
7	30" w x 38" h Flat Panel
8	38" h 90° Connector

Modul Extrusion Part List:

Item	Qty.	Description
25	1	26.5" h Round Vertical Extrusion

Steps

- 3) Set internal shelf atop supports.
- 4) Attach round vertical extrusion [25] to top of counter, then set counter atop base.
- 5) Attach literature racks to round vertical extrusion [25], see Literature Rack Attachment.
- 6) Attach monitor mount to round vertical extrusion [25], see Monitor Mount Attachment.
- 7) Attach graphic to front of assembled counter using stand-off barrels and caps
- 8) Repeat steps for additional workstation.

Steps

- 1) Assemble workstation base by starting at panel #1 and continue in numerical order.
- 2) Velcro internal shelf supports to inside assembled base.

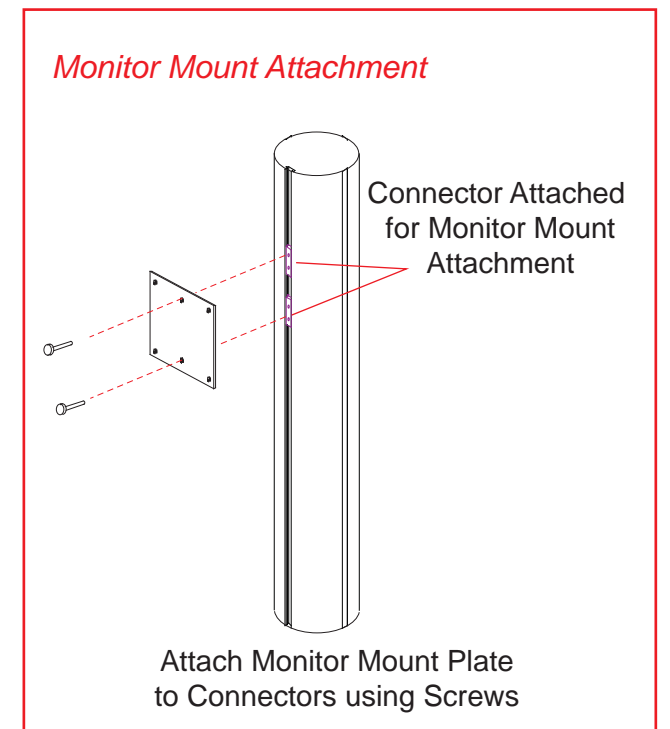
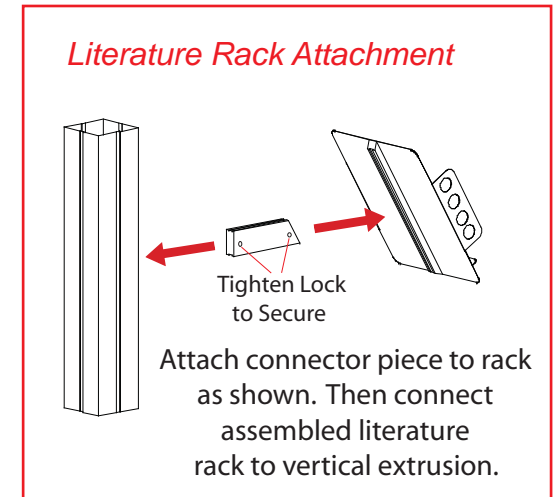
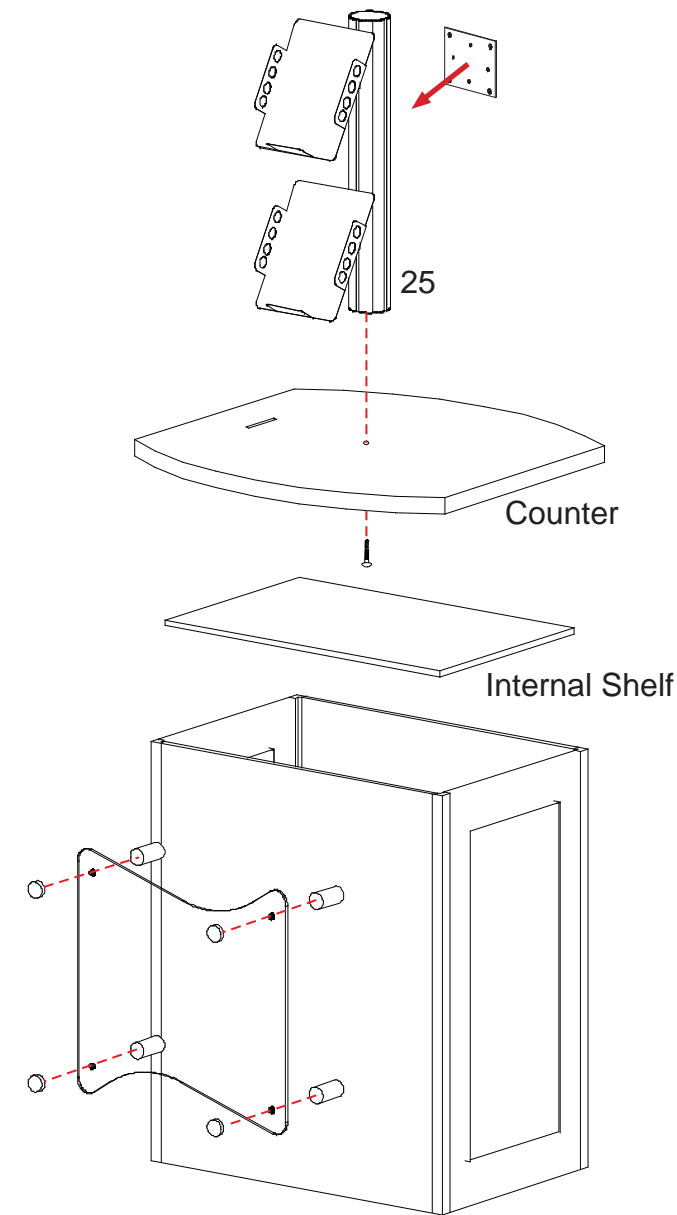
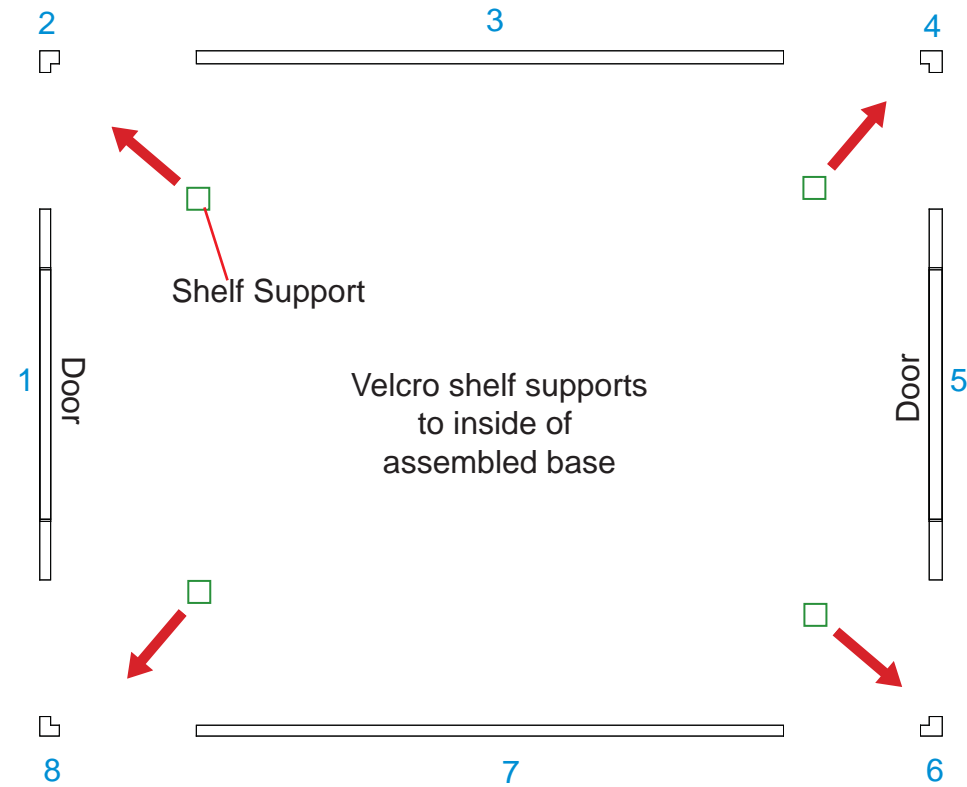

WHEN DISASSEMBLING ALUMINUM EXTRUSION, TIGHTEN ALL SETSCREWS AND LOCKS TO PREVENT LOSS DURING SHIPPING



Level 5



Level 6



Level 3



Level 4



Level 1



Level 2

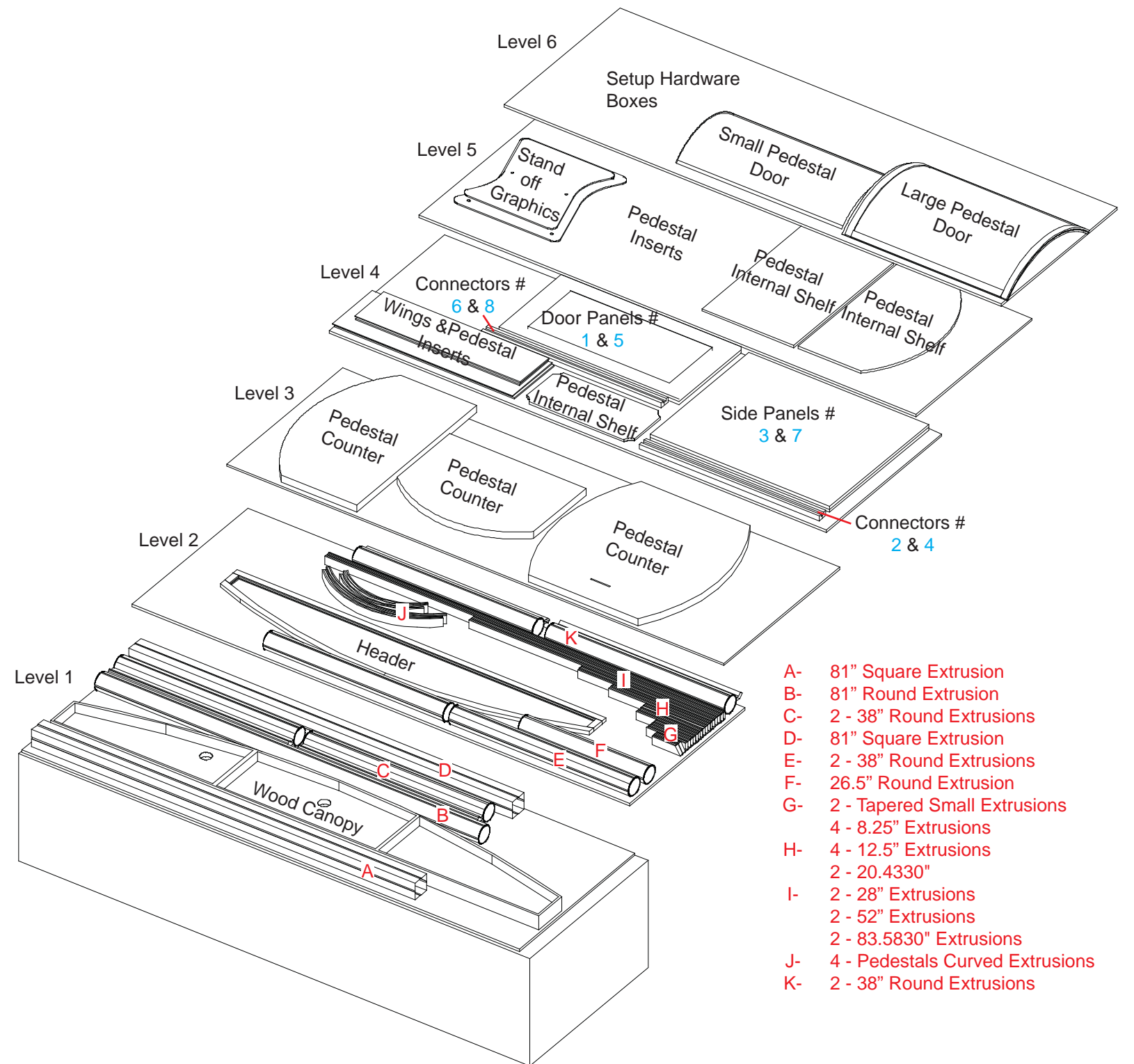

- A- 81" Square Extrusion
- B- 81" Round Extrusion
- C- 2 - 38" Round Extrusions
- D- 81" Square Extrusion
- E- 2 - 38" Round Extrusions
- F- 26.5" Round Extrusion
- G- 2 - Tapered Small Extrusions
- H- 4 - 8.25" Extrusions
- I- 4 - 12.5" Extrusions
- J- 2 - 20.4330"
- K- 2 - 28" Extrusions
- L- 2 - 52" Extrusions
- M- 2 - 83.5830" Extrusions
- N- 4 - Pedestals Curved Extrusions
- O- 2 - 38" Round Extrusions

WHEN DISASSEMBLING ALUMINUM EXTRUSION, TIGHTEN ALL SETSCREWS AND LOCKS TO PREVENT LOSS DURING SHIPPING



Level 5



Level 6



Level 3



Level 4



Level 1

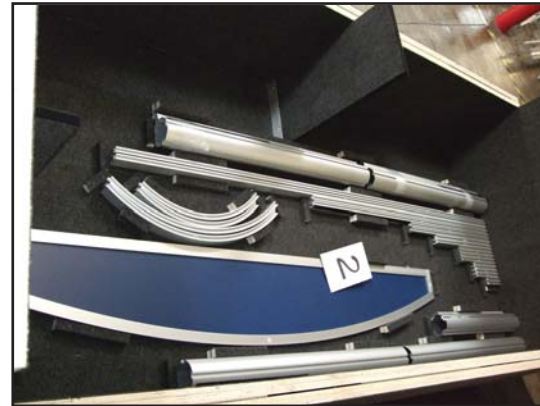

Level 2

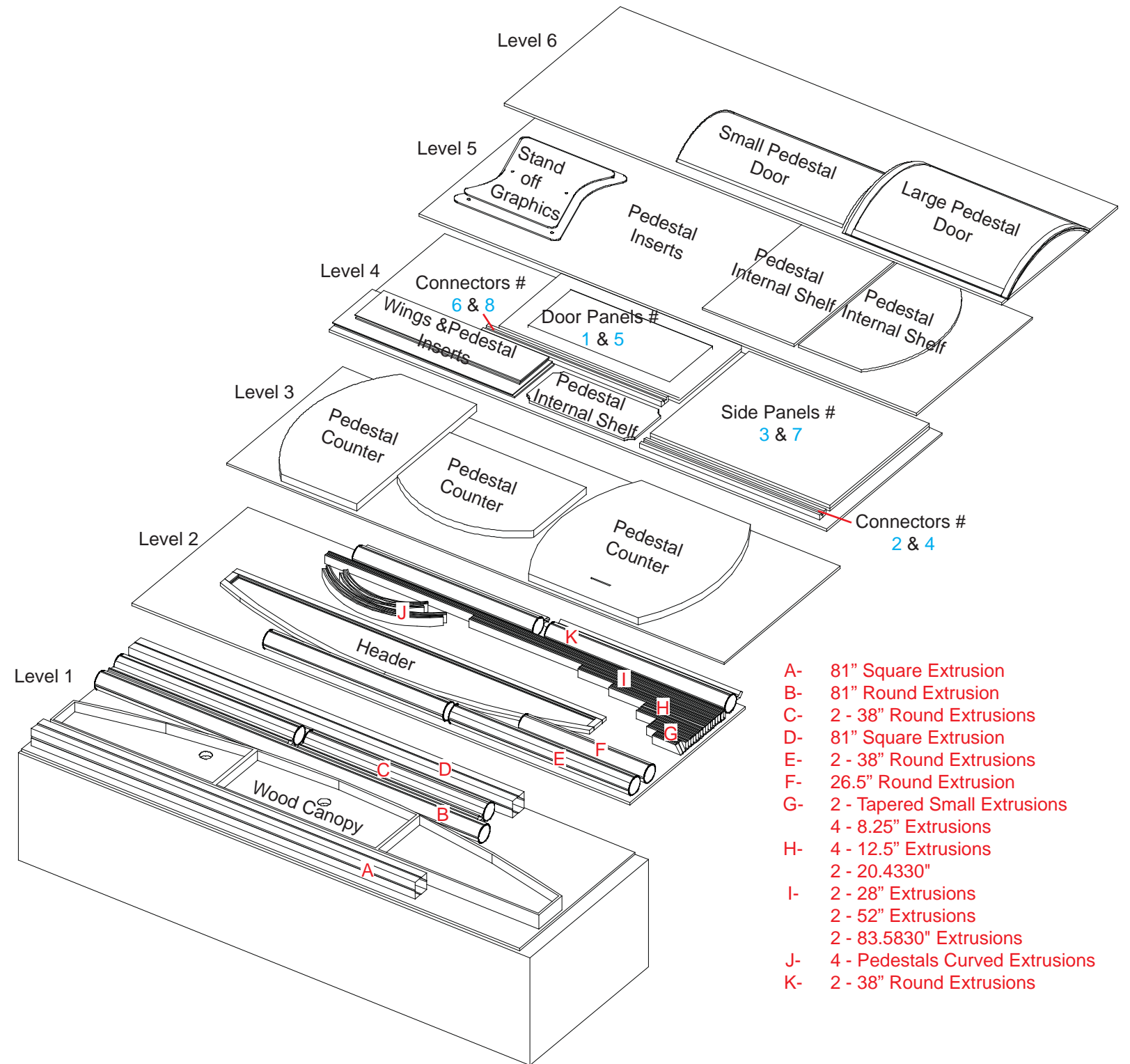

WHEN DISASSEMBLING ALUMINUM EXTRUSION, TIGHTEN ALL SETSCREWS AND LOCKS TO PREVENT LOSS DURING SHIPPING