

10'

10'

Plan View

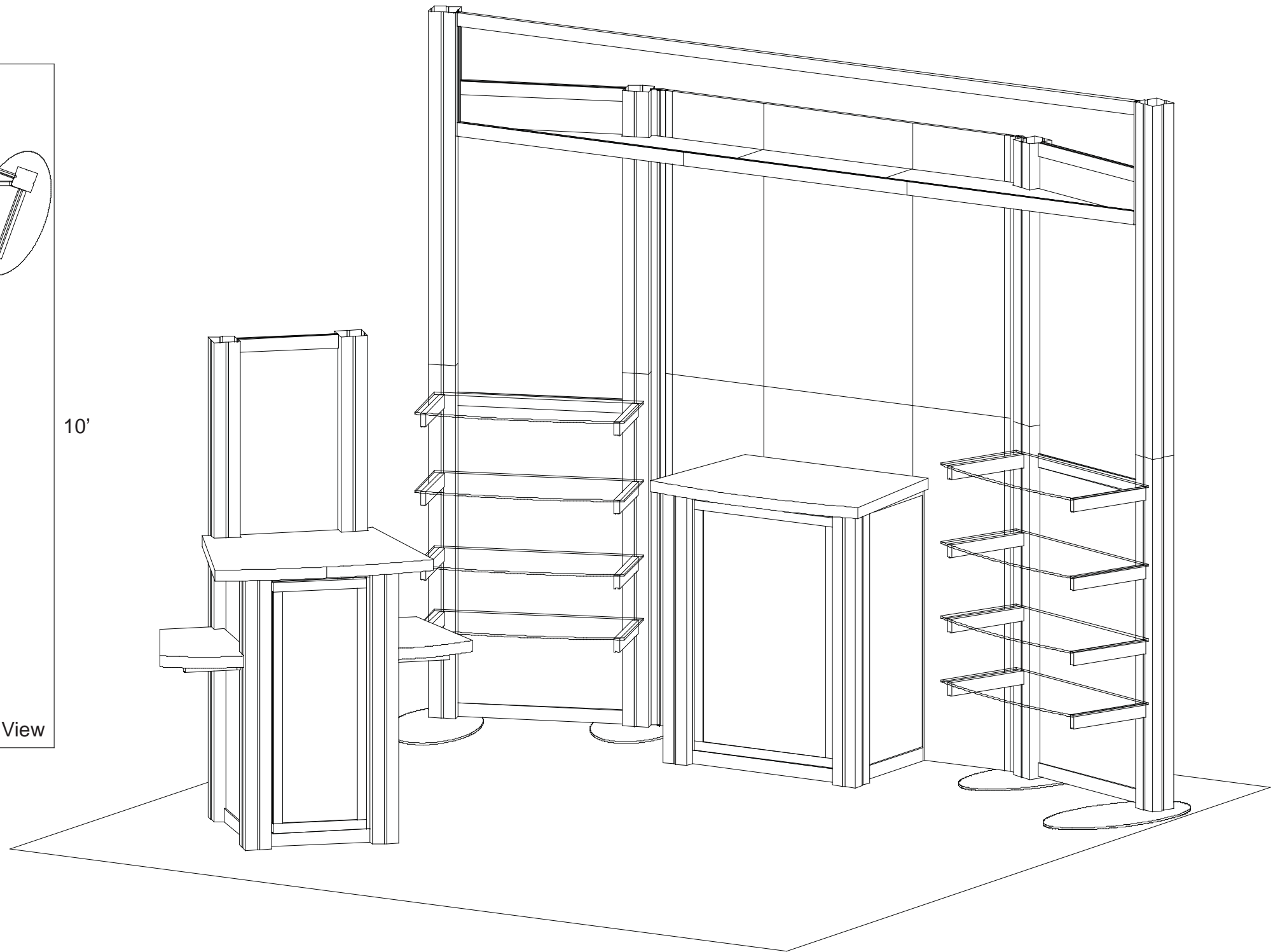

WHEN DISASSEMBLING ALUMINUM EXTRUSION, TIGHTEN ALL SETSCREWS AND LOCKS TO PREVENT LOSS DURING SHIPPING

visionary™ IDESIGNS

Using Your Setup Instructions

The Visionary Designs Setup Instructions are created specifically for your configuration. They are laid out sequentially, including an exploded view of the entire display, and then a logical series of detailed steps to assemble the main structure and components. We encourage you to study the instructions **before** attempting to assemble your exhibit.

Each page reminds you to tighten the setscrews after disassembling your exhibit to prevent loss of the locks and setscrews (see below in RED). This is **VERY IMPORTANT**.

Cleaning and Packing Your Display

- 1) Use care when cleaning aluminum extrusion or acrylic inserts. Use only non-abrasive cleaners.
- 2) When cleaning laminate inserts or countertops, use mild cleansers and a soft material such as cotton.
- 3) Keep all display components away from extreme heat and long exposure to sunlight to avoid warping and fading.
- 4) Retain all packing material. It will make re-packing much easier and will reduce the likelihood of shipping damage.



The Tool

Most Visionary Designs exhibits can be assembled with the supplied Hex Key Tool. Occasionally, a flat head screwdriver may be required.



Typical Connection

Most horizontal extrusion connections have a patented expandable lock. This lock inserts into the groove of an opposing extrusion. Tightening the lock with the Hex Key Tool expands the lock and creates a strong positive connection.



Typical Connection (cont'd)

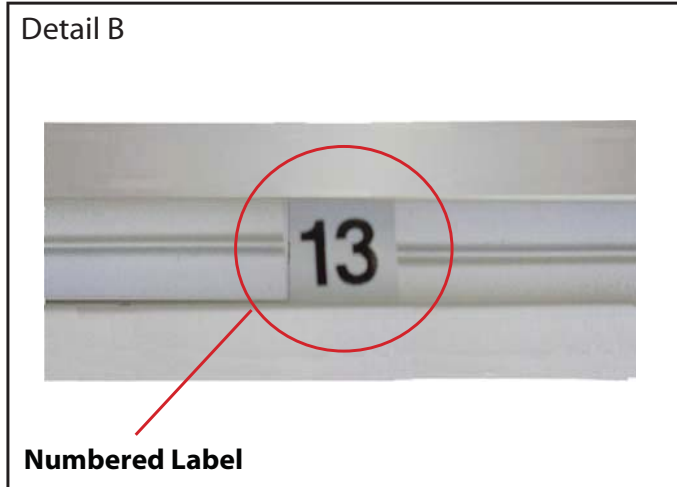

Detail B

Numbered Label

Each extrusion contains a numbered label which corresponds with setup instructions. The label is located within a groove of the extrusion (when possible). With Visionary Designs the labels contain Black numbers unless otherwise specified.



Detail C

Horizontal Inline Connection (remove only one setscrew)

Remove only (1) setscrew when disassembling. Replace setscrew in extrusion after assembling it. Before packing, replace setscrew in extrusion to avoid losing it.

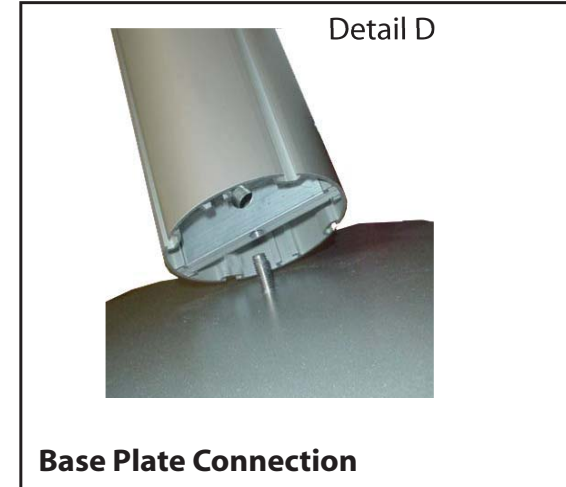

Detail D

Base Plate Connection

Attach base plate to round or square vertical extrusion using the bolt provided. Be careful not to strip the threads.

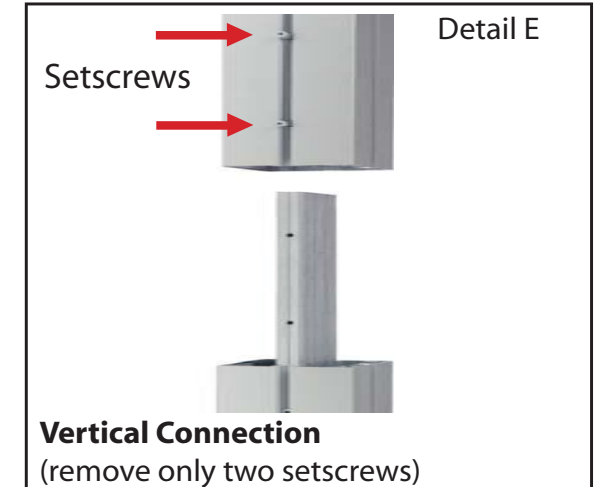

Detail E

Vertical Connection
(remove only two setscrews)

When vertical extrusions are packed in portable cases rather than crates or tubs, they must be broken down into smaller sections which then require assembly.

Remove only (2) setscrews when disassembling. Replace setscrews in extrusion after assembling it. Before packing, replace setscrews in extrusion to avoid losing them.

WHEN DISASSEMBLING ALUMINUM EXTRUSION, TIGHTEN ALL SETSCREWS AND LOCKS TO PREVENT LOSS DURING SHIPPING

866.652.2100

Modul Extrusions Part List

Item	Qty.	Description
1	2	Base Plate
1a	2	Base Plate
2	1	47.5" h Vertical Extrusion
2a	1	38" h Vertical Extrusion
3	1	47.5" h Vertical Extrusion
3a	1	38" h Vertical Extrusion
7	1	47.5" h Vertical Extrusion
7a	1	38" h Vertical Extrusion
8	1	47.5" h Vertical Extrusion
8a	1	38" h Vertical Extrusion
9	1	22.369" w Horizontal Extrusion

Euro LT Panel System - Level 1

Item Number	Description
3	47.5" h Cap
4	14.125" w x 47.5" h Panel
5	23" w x 47.5" h Panel
6	14.125" w x 47.5" h Panel
7	47.5" h Cap

Euro LT Panel System - Level 2

Item Number	Description
3a	38" h Cap
4	14.125" w x 38" h Panel
5	23" w x 38" h Panel
6	14.125" w x 38" h Panel
7a	38" h Cap

Steps:

- 1) Attach lower vertical extrusions to base plates.
- 2) Attach upper vertical extrusions to lower vertical extrusions.
- 3) Connect panel 4 to cap 3 and continue in numerical order.
- 4) Connect panel 4 to cap 3a and continue in numerical order.
- 5) Temporarily use 3-piece ceiling panels to set angle of backwall.
- 6) Attach horizontal extrusions [9] between vertical extrusions, placing inserts between horizontal bars as shown.
- 7) Remove ceiling panels.

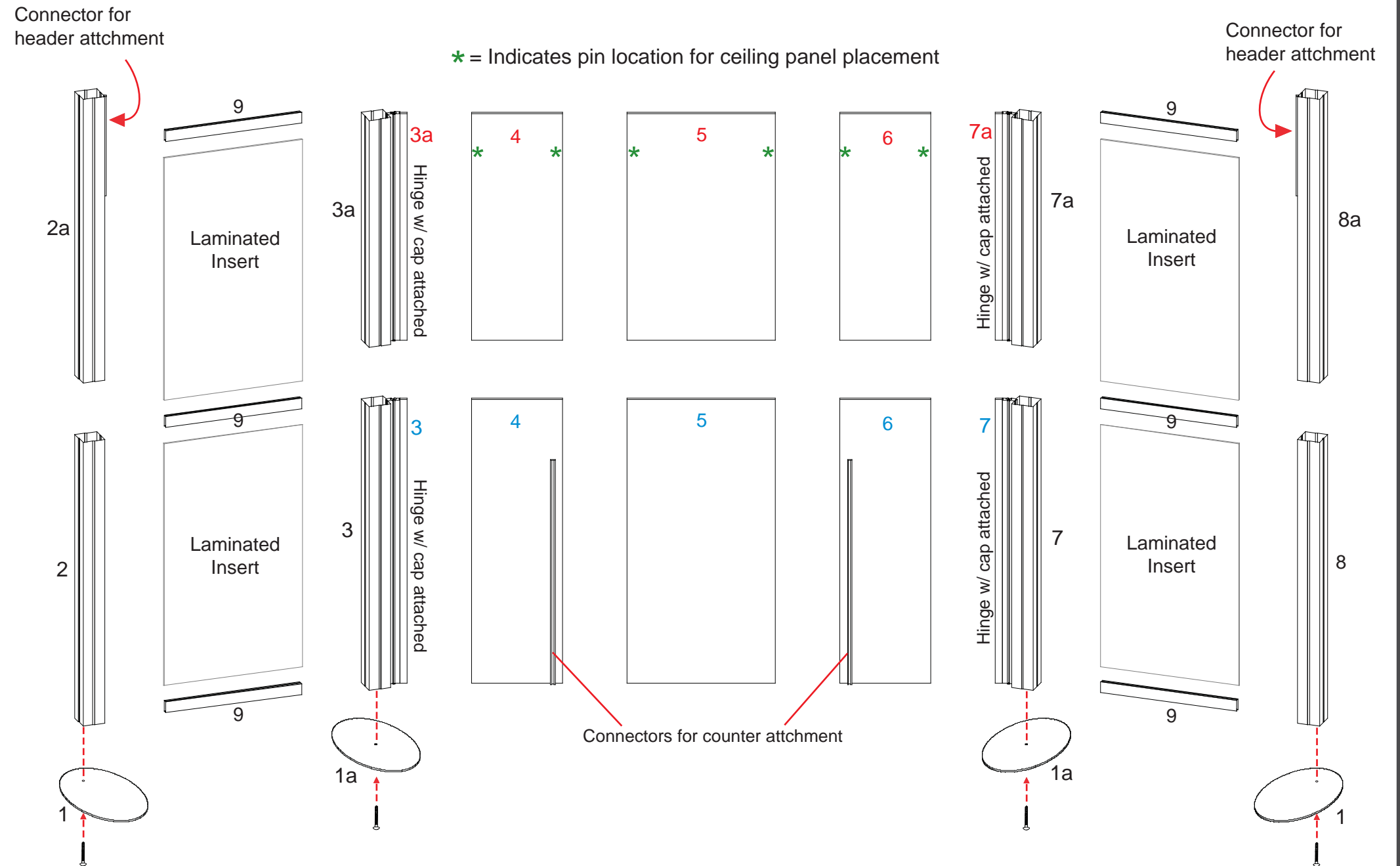
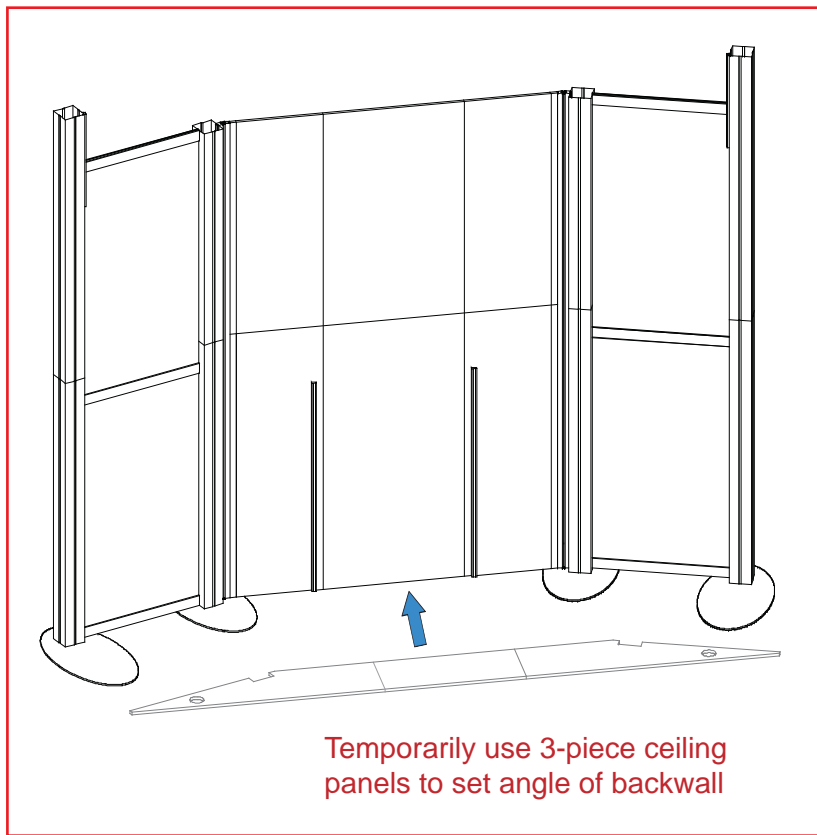

WHEN DISASSEMBLING ALUMINUM EXTRUSION, TIGHTEN ALL SETSCREWS AND LOCKS TO PREVENT LOSS DURING SHIPPING

Item	Qty.	Description
10a/11a	1/1	35" w Horizontal Extrusion
10b/11b	1/1	34.5" w Horizontal Extrusion
10c/11c	1/1	35" w Horizontal Extrusion
12	1	37.5" h Vertical Extrusion
13	1	37.5" h Vertical Extrusion
14	2	22.5" w Horizontal Extrusion
15	4	15.5" w Horizontal Extrusion

Steps:

- 1) Connect horizontal pieces together [10a to 10b to 10c and 11a to 11b to 11c].
- 2) Attach horizontal assemblies between connectors as shown.
- 3) Attach horizontal extrusions [15] between connectors located on backwall panels and vertical extrusions, placing inserts between horizontal bars.
- 4) Attach horizontal extrusions [14] between vertical extrusions [12 and 13], attaching door between horizontal bars.
- 5) Velcro shelf supports inside assembled base, then set internal shelf atop supports.
- 6) Place counter top on assembled base.

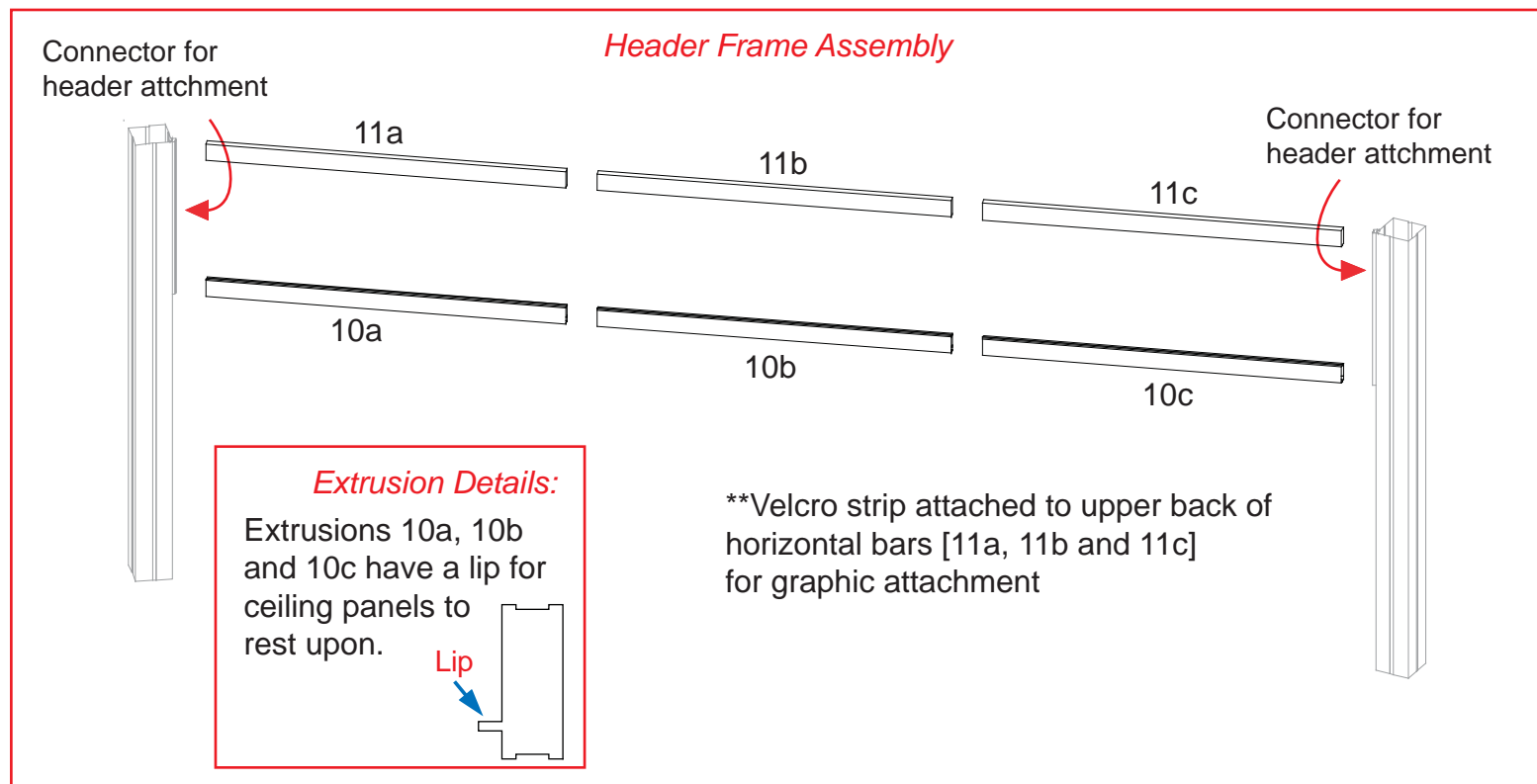
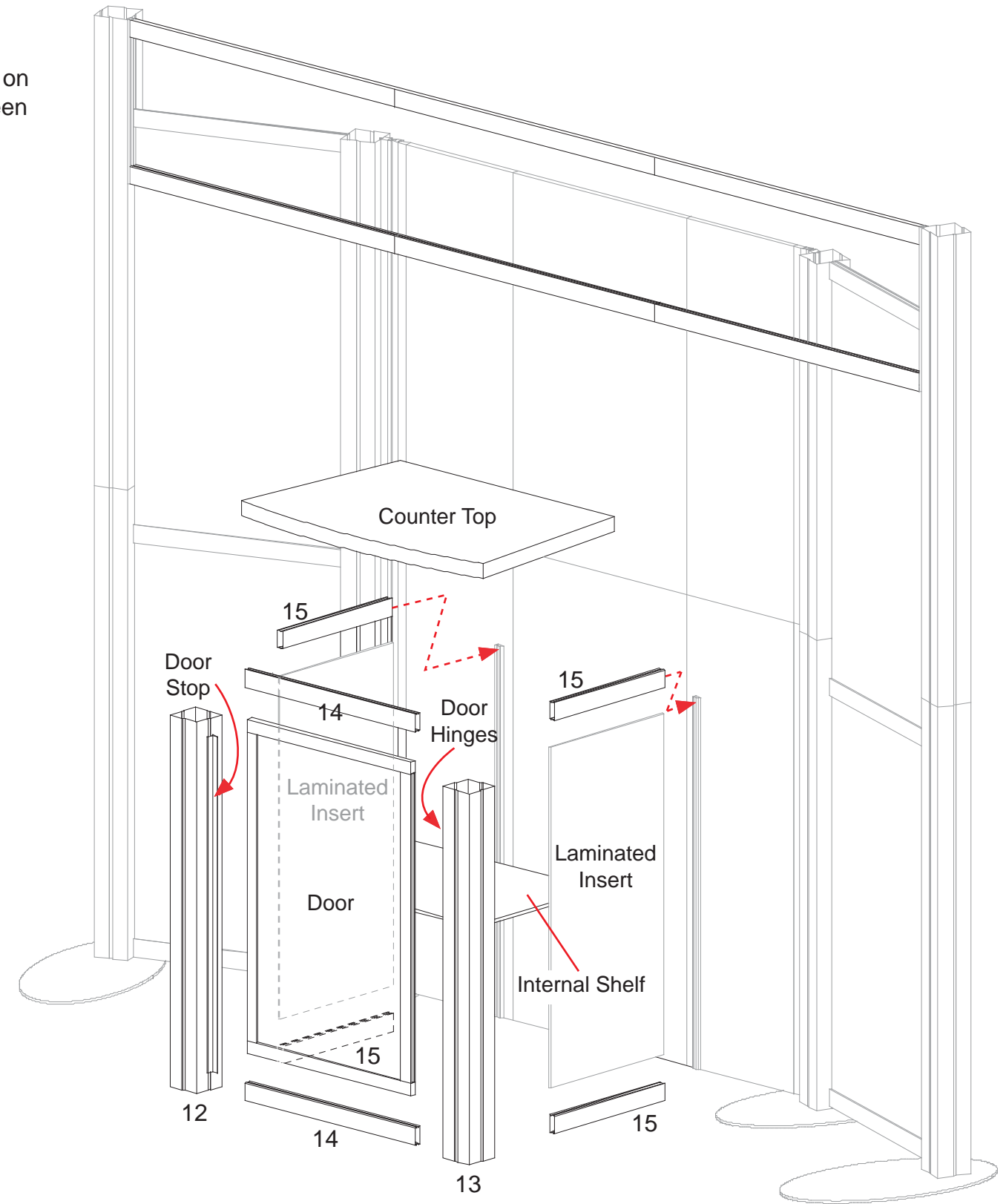

WHEN DISASSEMBLING ALUMINUM EXTRUSION, TIGHTEN ALL SETSCREWS AND LOCKS TO PREVENT LOSS DURING SHIPPING

Item	Qty.	Description
16	16	12" w Shelf Support

Steps:

- 1) Attach pins to backwall panels where indicated.
- 2) Place ceiling panels atop pins and lip of extrusion bars.
- 3) Apply header graphic to assembled frame, see Header Graphic Attachment.
- 4) Attach shelf support extrusions [16] to backwall vertical extrusions at desired height, then place clear shelves atop supports.
- 5) Attach monitor mount to center panel where indicated, see Monitor Mount Attachment details.

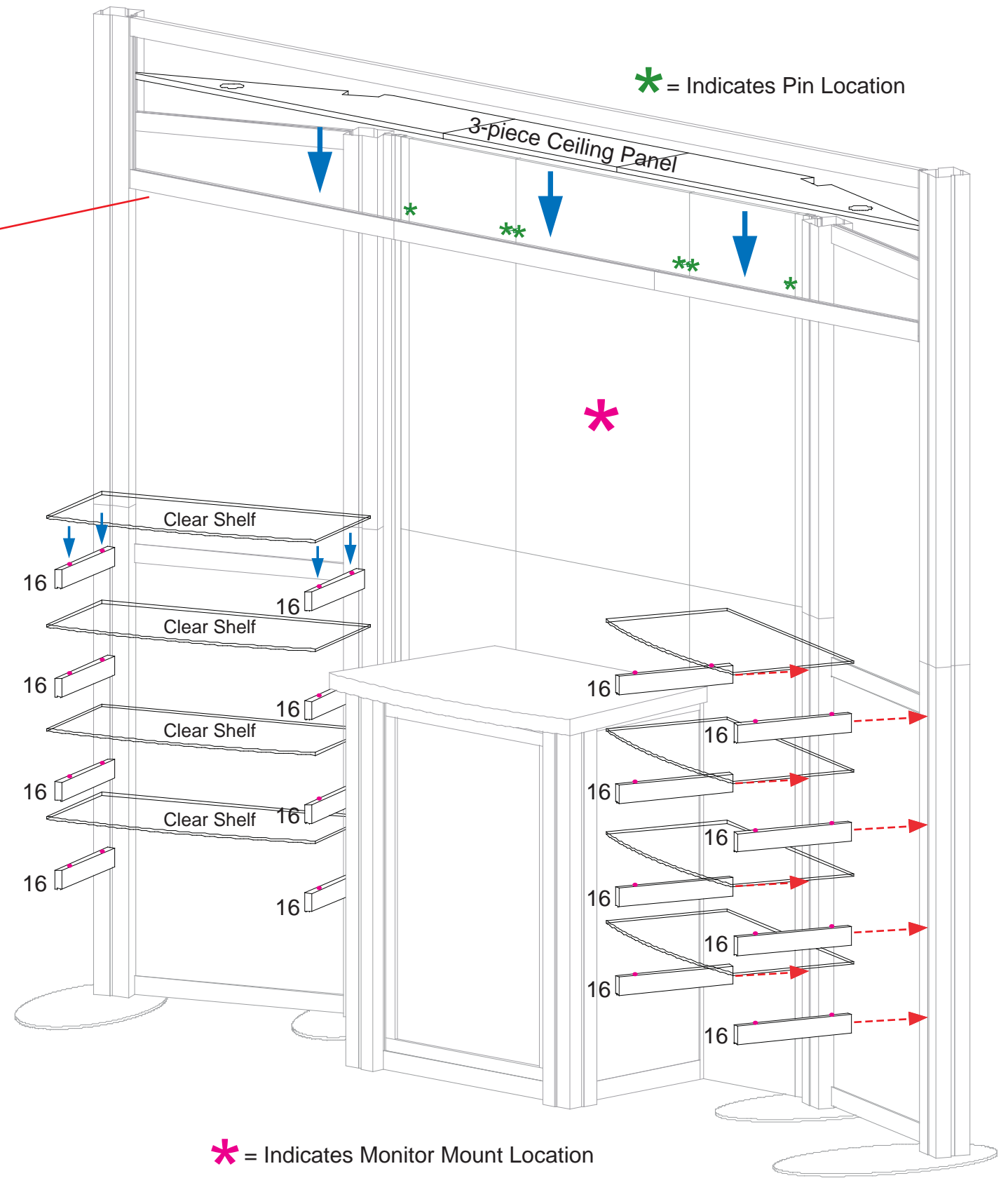
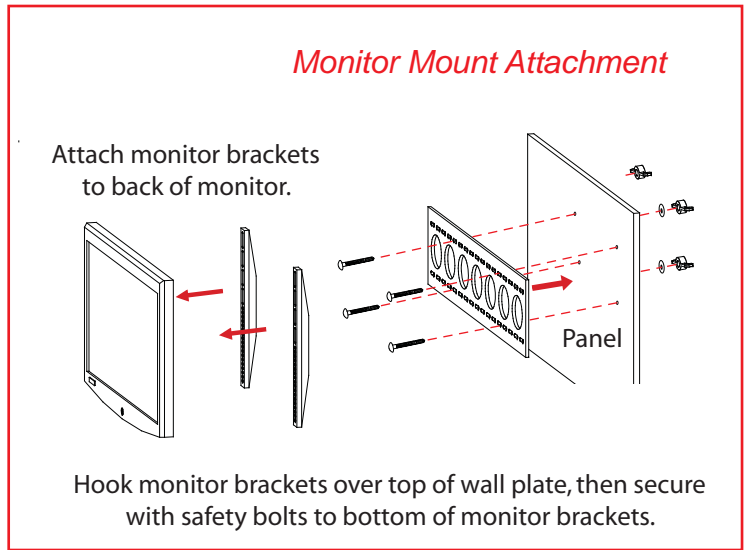
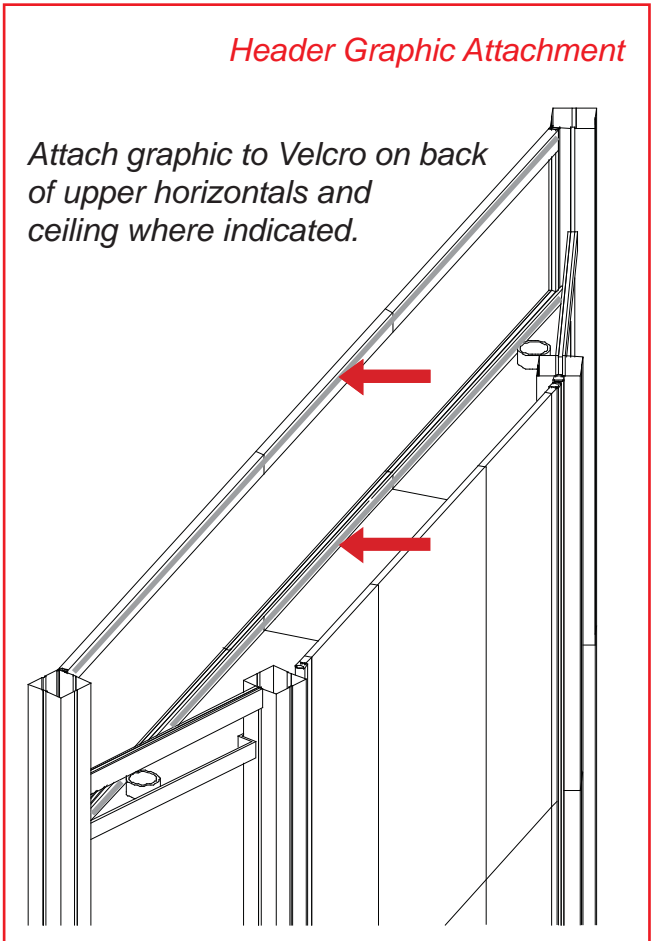
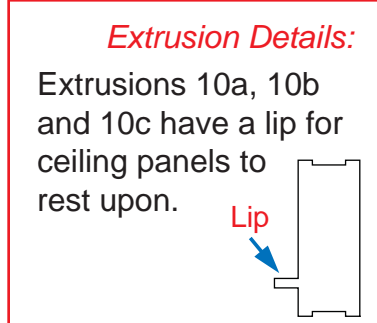

WHEN DISASSEMBLING ALUMINUM EXTRUSION, TIGHTEN ALL SETSCREWS AND LOCKS TO PREVENT LOSS DURING SHIPPING

866.652.2100

Item	Qty.	Description
17	1	37.5" h Vertical Extrusion
18	1	37.5" h Vertical Extrusion
19	1	37.5" h Vertical Extrusion
20	1	37.5" h Vertical Extrusion
21	1	27" h Vertical Extrusion
22	1	27" h Vertical Extrusion
23	5	13.5" w Horizontal Extrusion
24	4	14.5" w Horizontal Extrusion

Steps:

- 1) Attach upper vertical extrusions to lower extrusions [21 to 19 and 22 to 20].
- 2) Attach horizontal extrusions [23 and 24] between vertical extrusions, placing inserts and attaching door where indicated.
- 3) Velcro shelf supports to inside of assembled base, then set internal shelf atop supports.
- 4) Attach shelf supports [25] to connectors where indicated, then set shelves atop supports.
- 5) Place counter top on assembled base.
- 6) Attach monitor mount to assembled workstation where indicated, see Monitor Mount Attachment details.

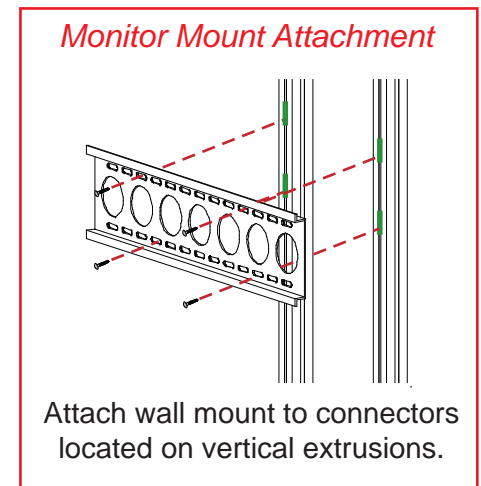
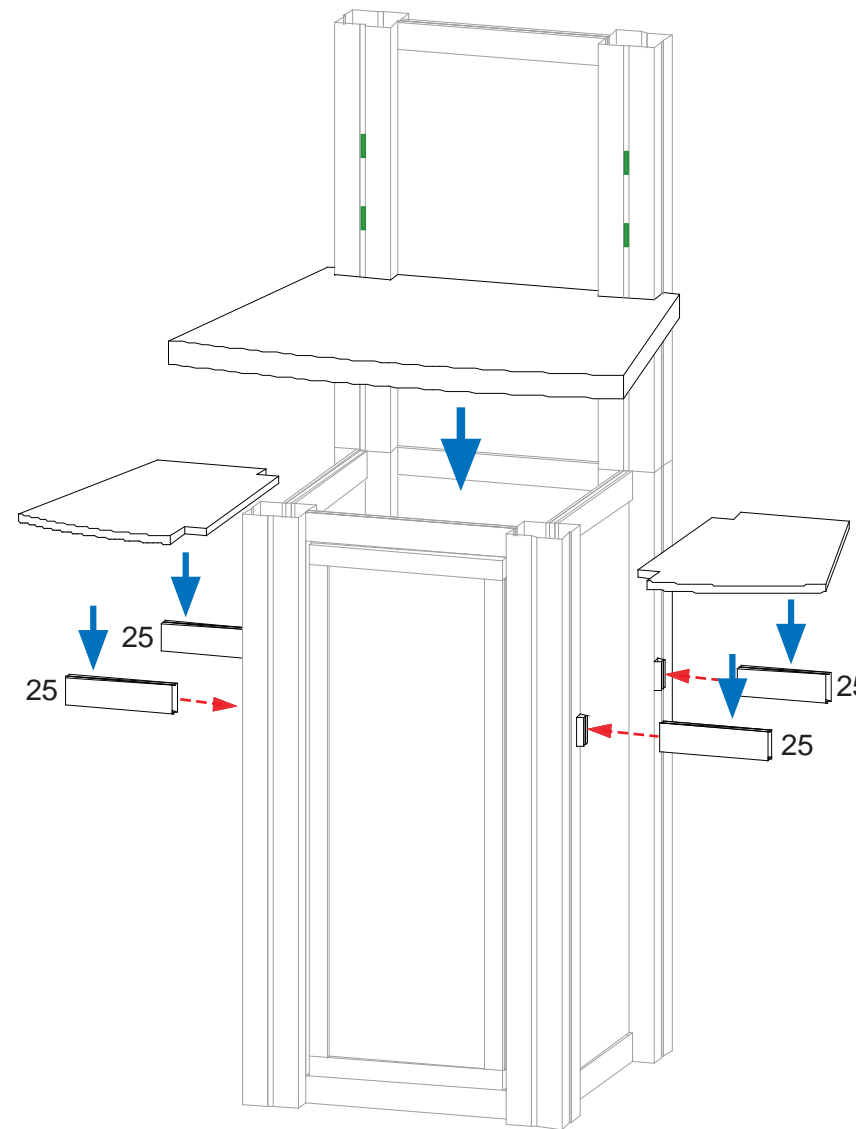
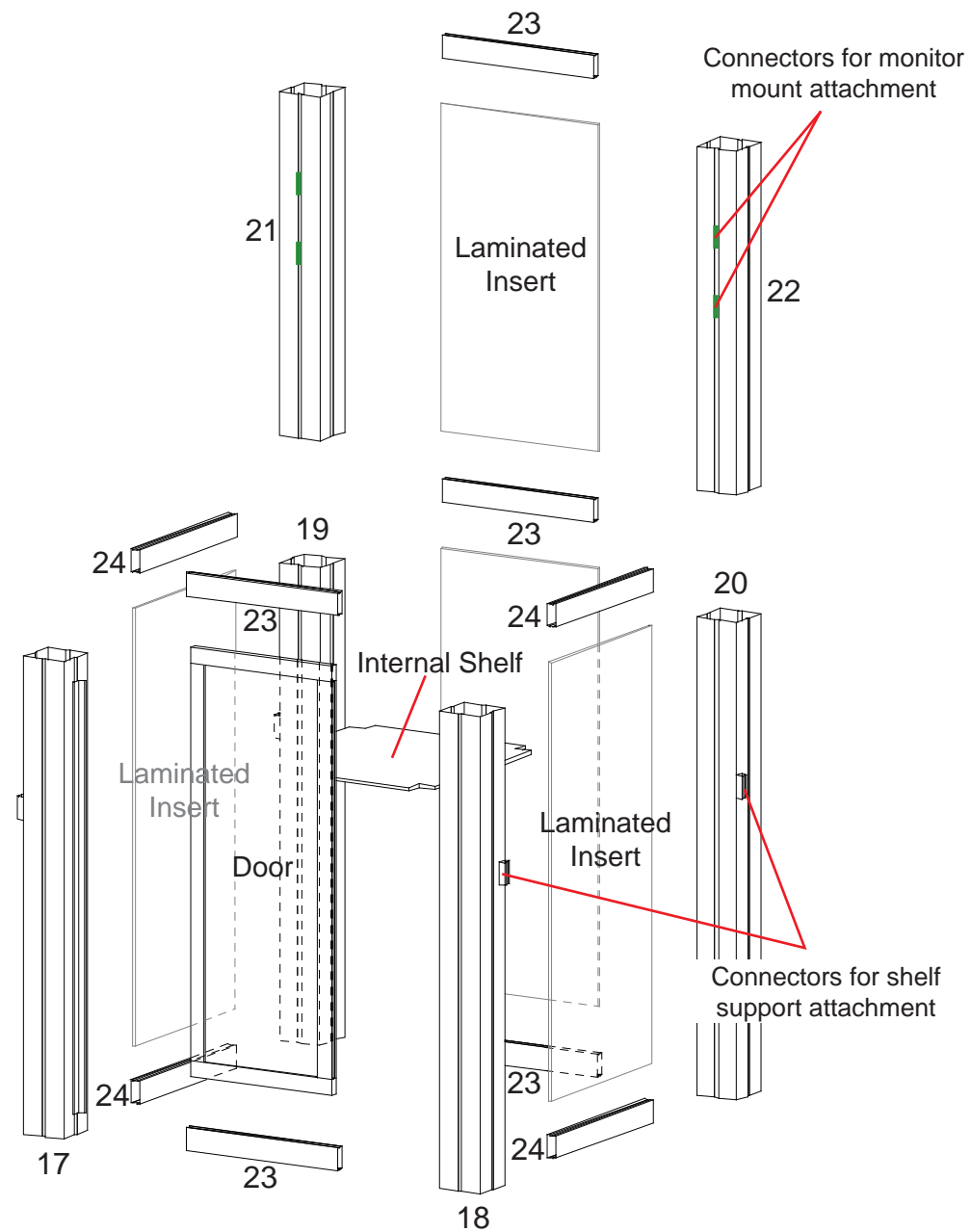
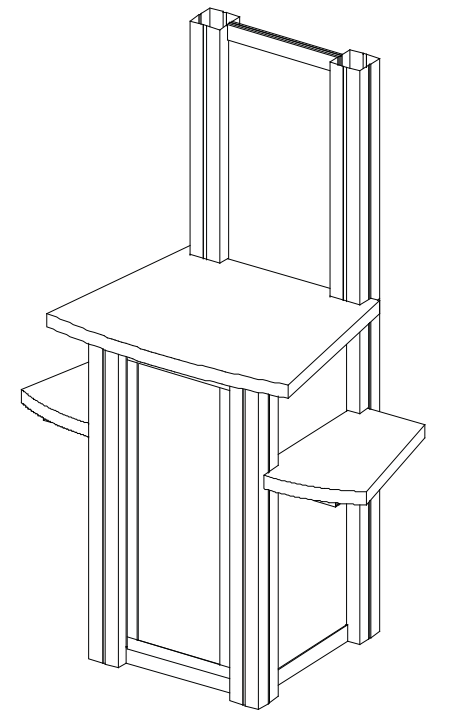

WHEN DISASSEMBLING ALUMINUM EXTRUSION, TIGHTEN ALL SETSCREWS AND LOCKS TO PREVENT LOSS DURING SHIPPING

Backwall Components

Backwall Inserts

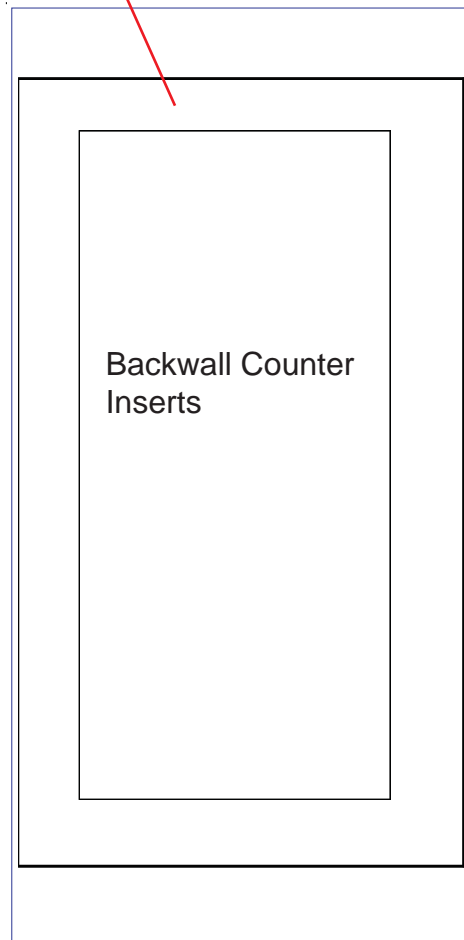

Level 1

Ceiling Pieces

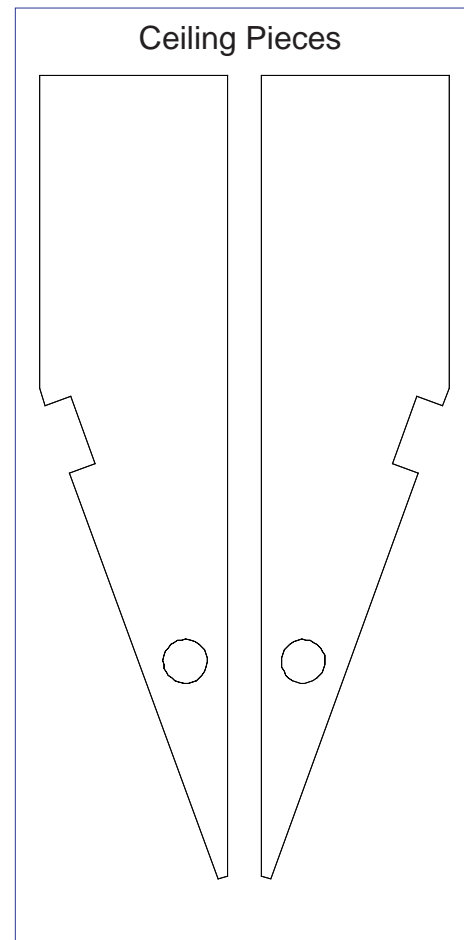

Level 2

(4) Plex Shelves

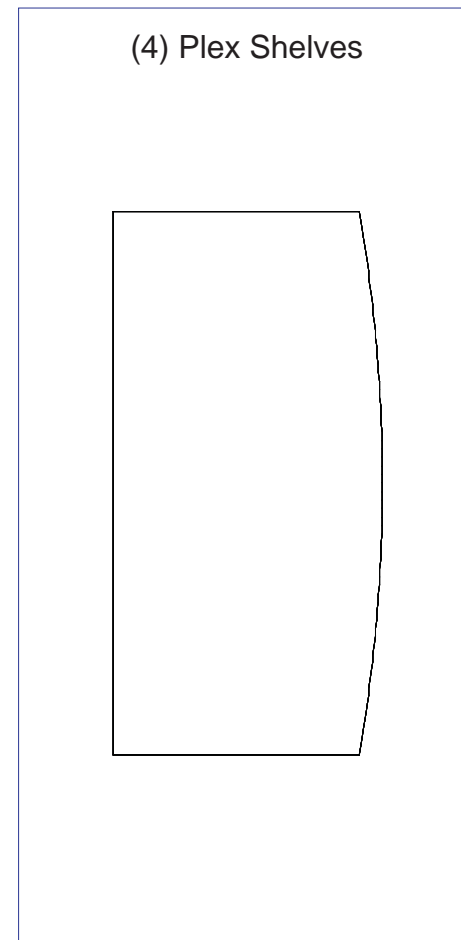

Level 3

Ceiling Piece

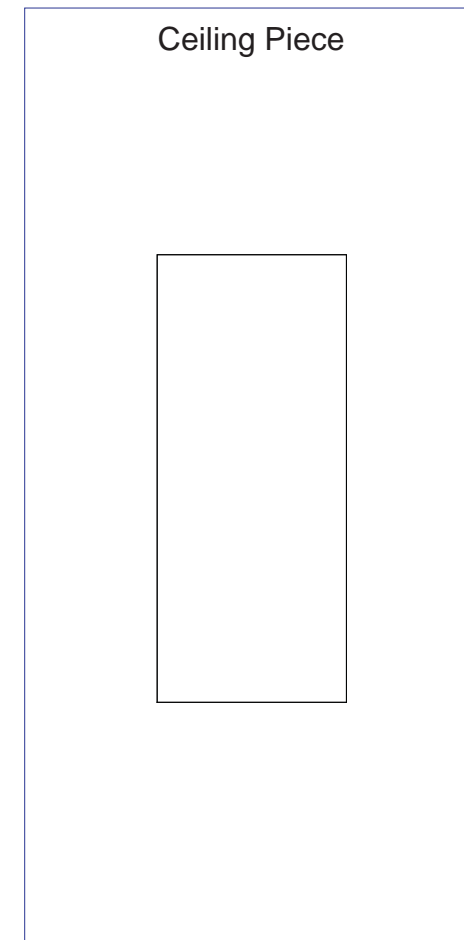

Level 4

**Top view of each level

WHEN DISASSEMBLING ALUMINUM EXTRUSION, TIGHTEN ALL SETSCREWS AND LOCKS TO PREVENT LOSS DURING SHIPPING

Backwall Components

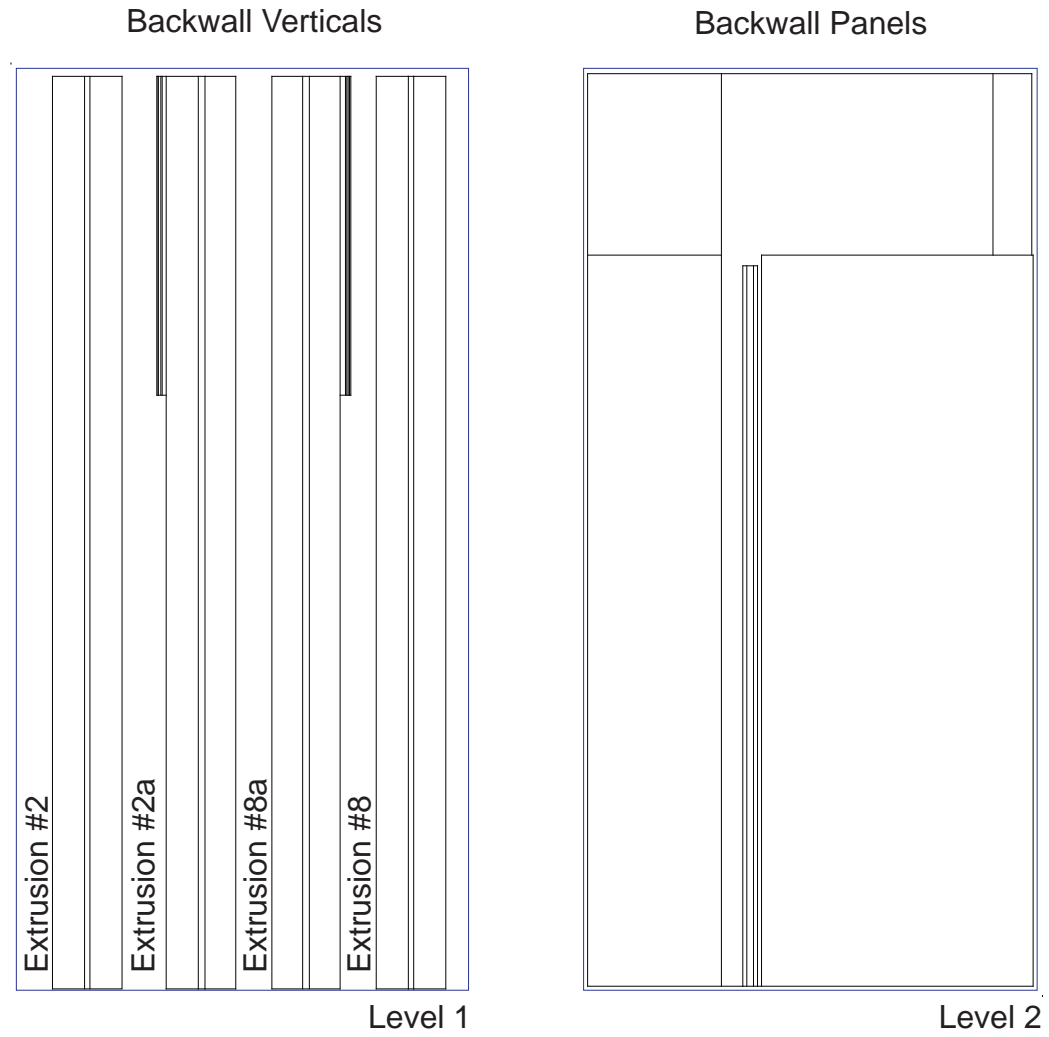

**Top view of each level

WHEN DISASSEMBLING ALUMINUM EXTRUSION, TIGHTEN ALL SETSCREWS AND LOCKS TO PREVENT LOSS DURING SHIPPING

Backwall Components

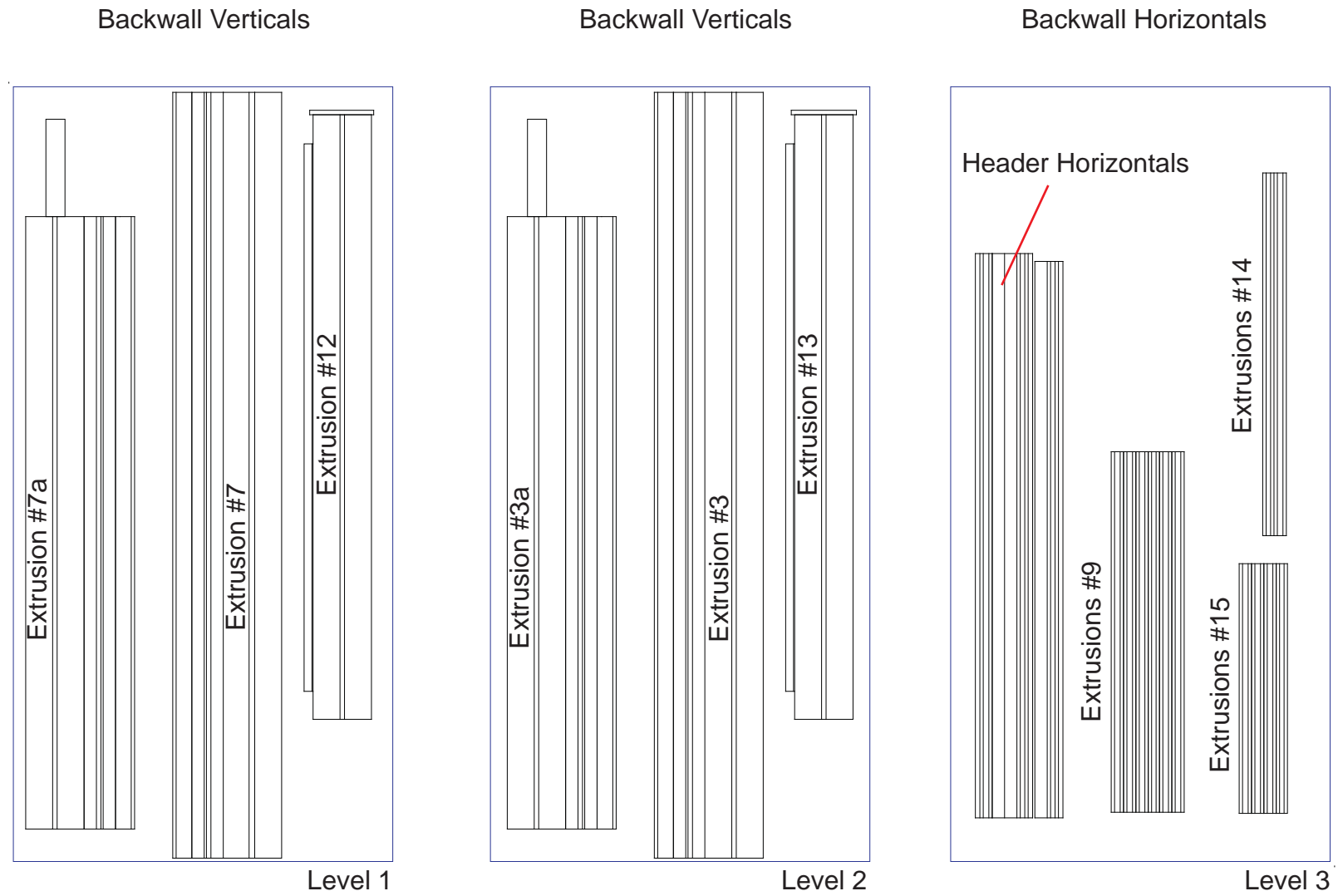

**Top view of each level

WHEN DISASSEMBLING ALUMINUM EXTRUSION, TIGHTEN ALL SETSCREWS AND LOCKS TO PREVENT LOSS DURING SHIPPING

Backwall Components

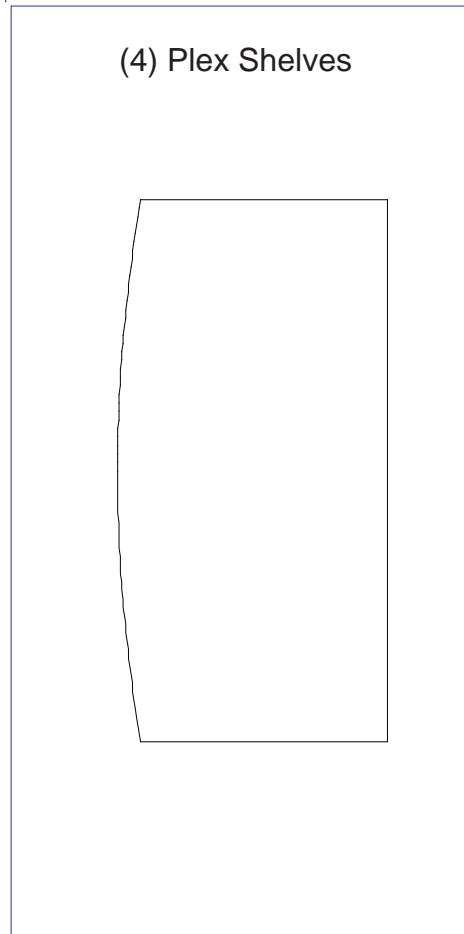

Level 1

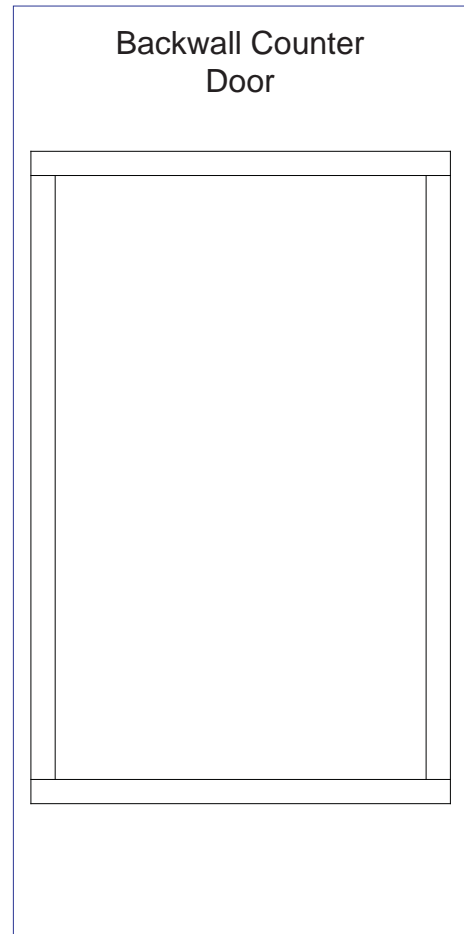

Level 2

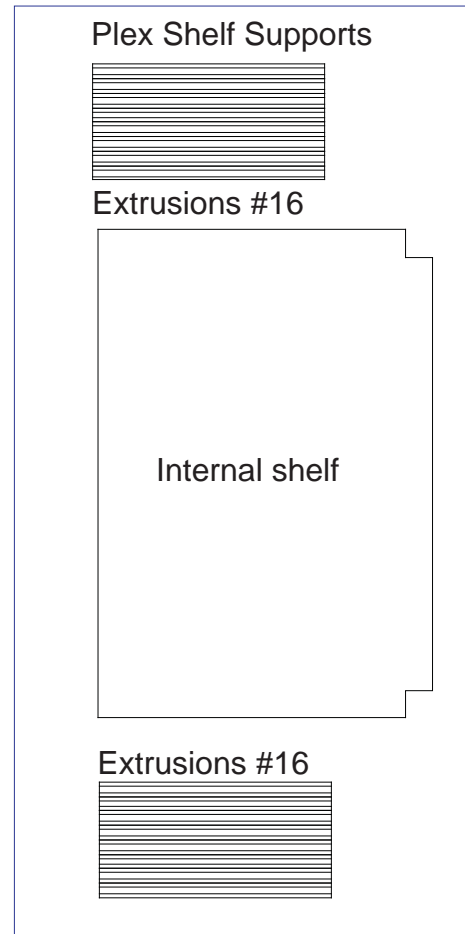

Level 3

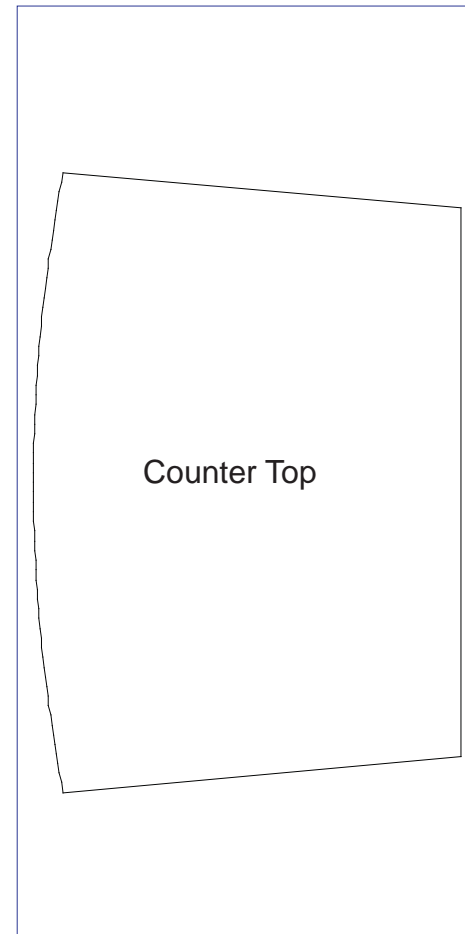

Level 4

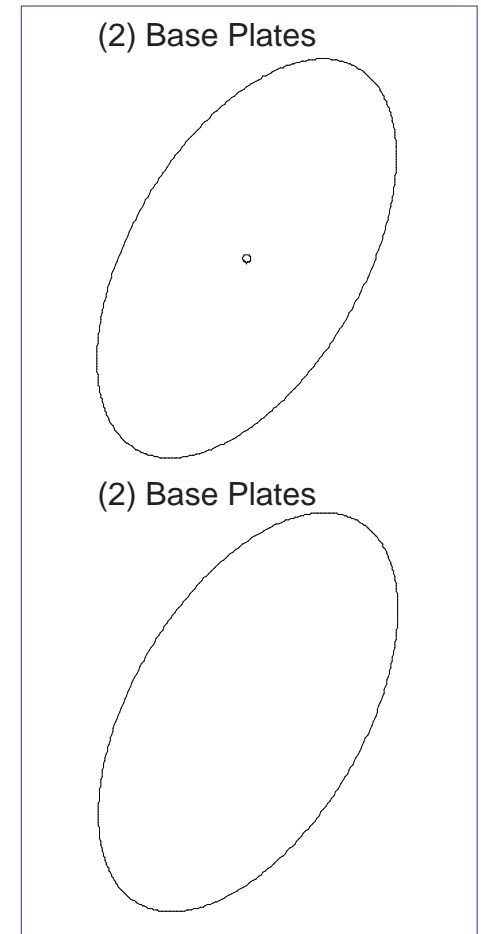

Level 5

**Top view of each level

WHEN DISASSEMBLING ALUMINUM EXTRUSION, TIGHTEN ALL SETSCREWS AND LOCKS TO PREVENT LOSS DURING SHIPPING

Workstation Kiosk Components

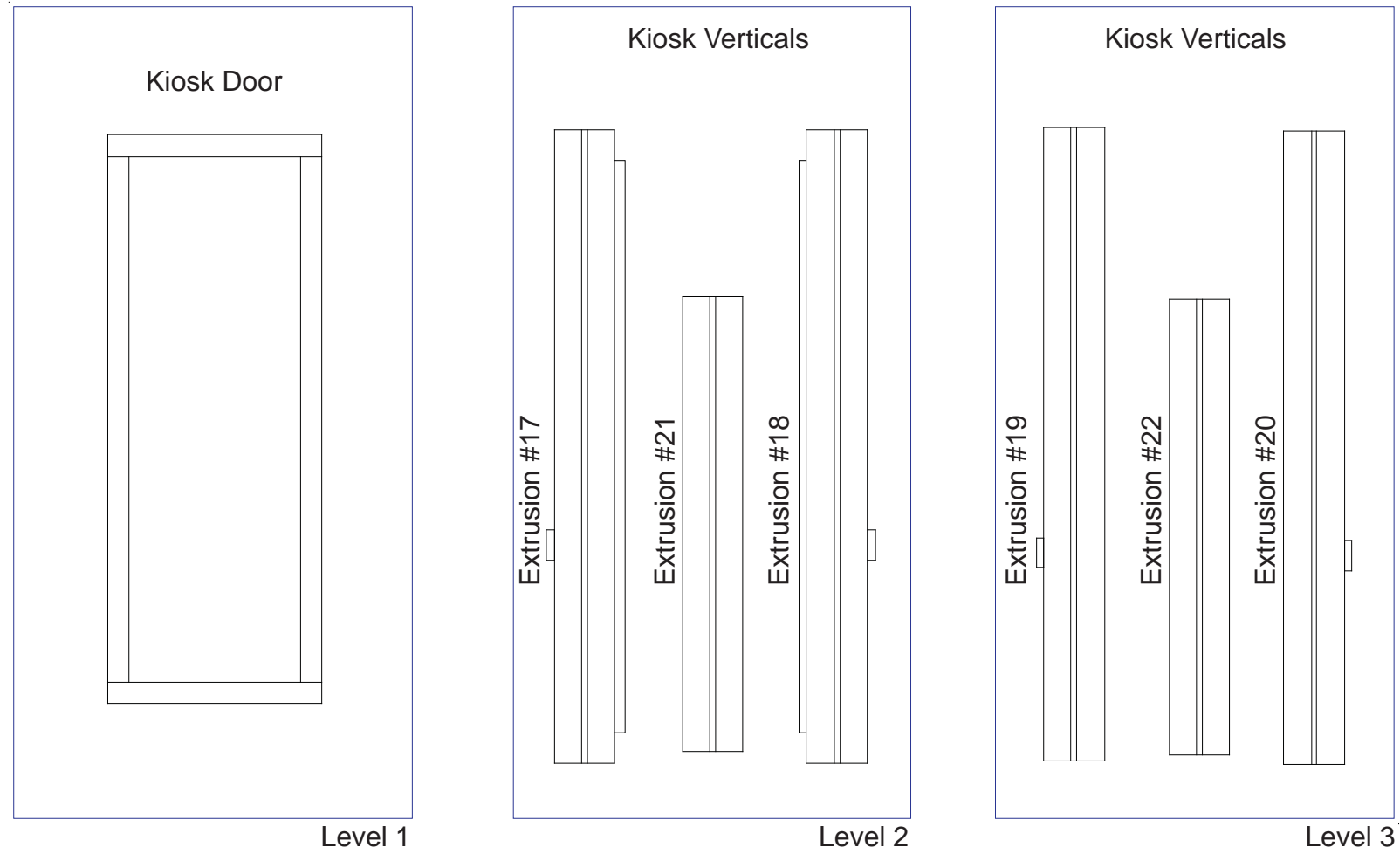

**Top view of each level

WHEN DISASSEMBLING ALUMINUM EXTRUSION, TIGHTEN ALL SETSCREWS AND LOCKS TO PREVENT LOSS DURING SHIPPING

Workstation Kiosk Components

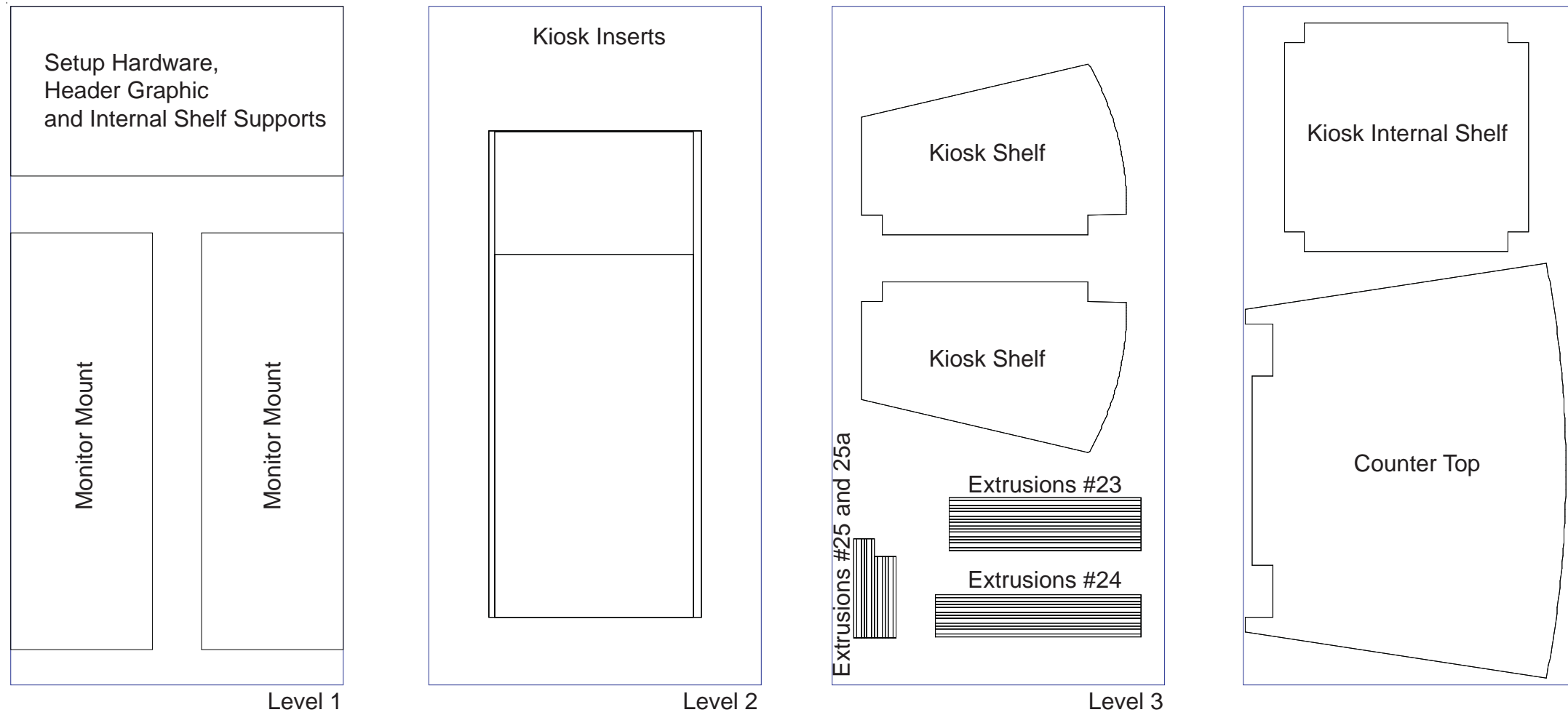

**Top view of each level

WHEN DISASSEMBLING ALUMINUM EXTRUSION, TIGHTEN ALL SETSCREWS AND LOCKS TO PREVENT LOSS DURING SHIPPING