

# euro It | *HYBRIDS*

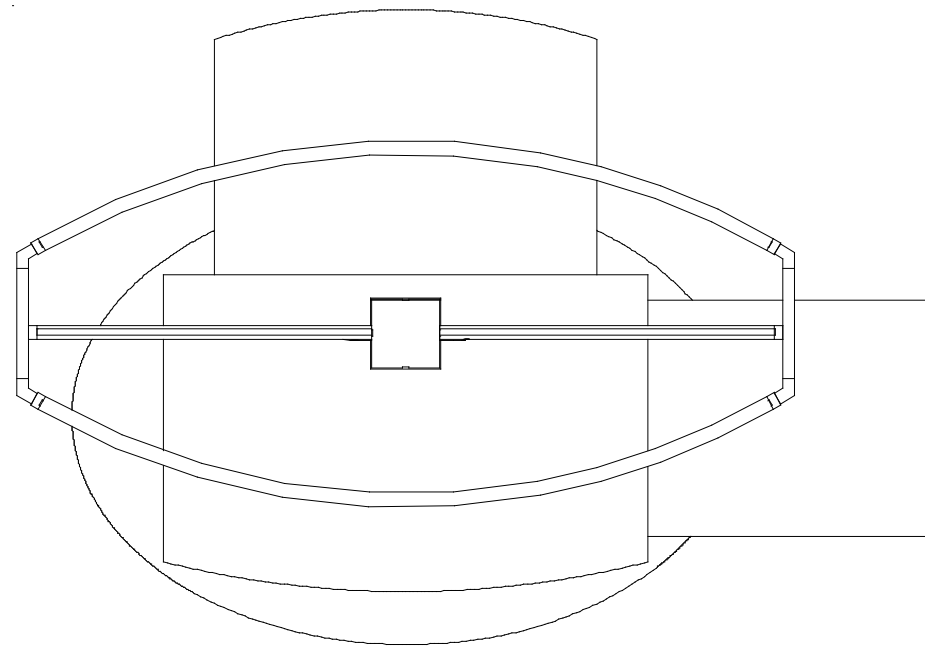

Plan View

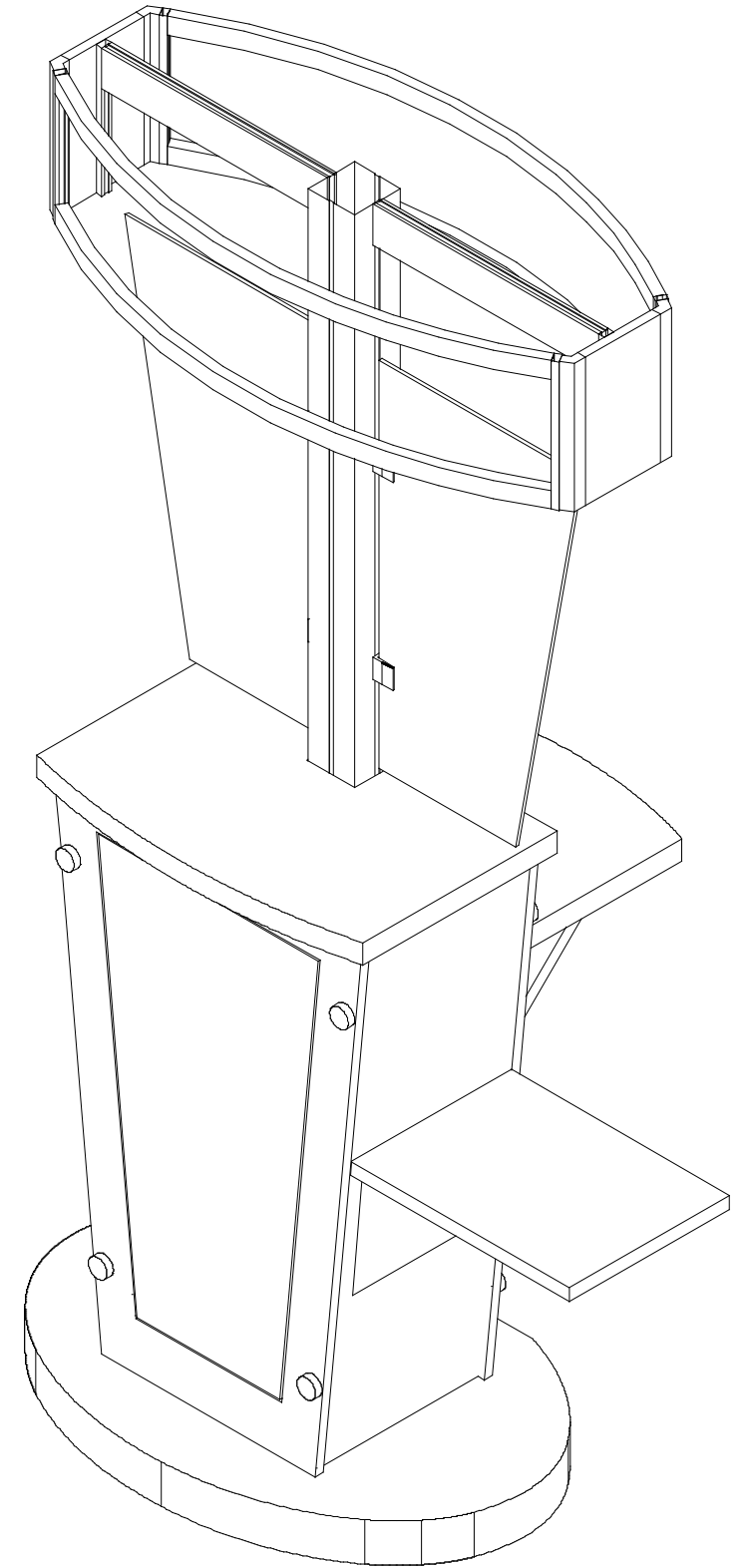
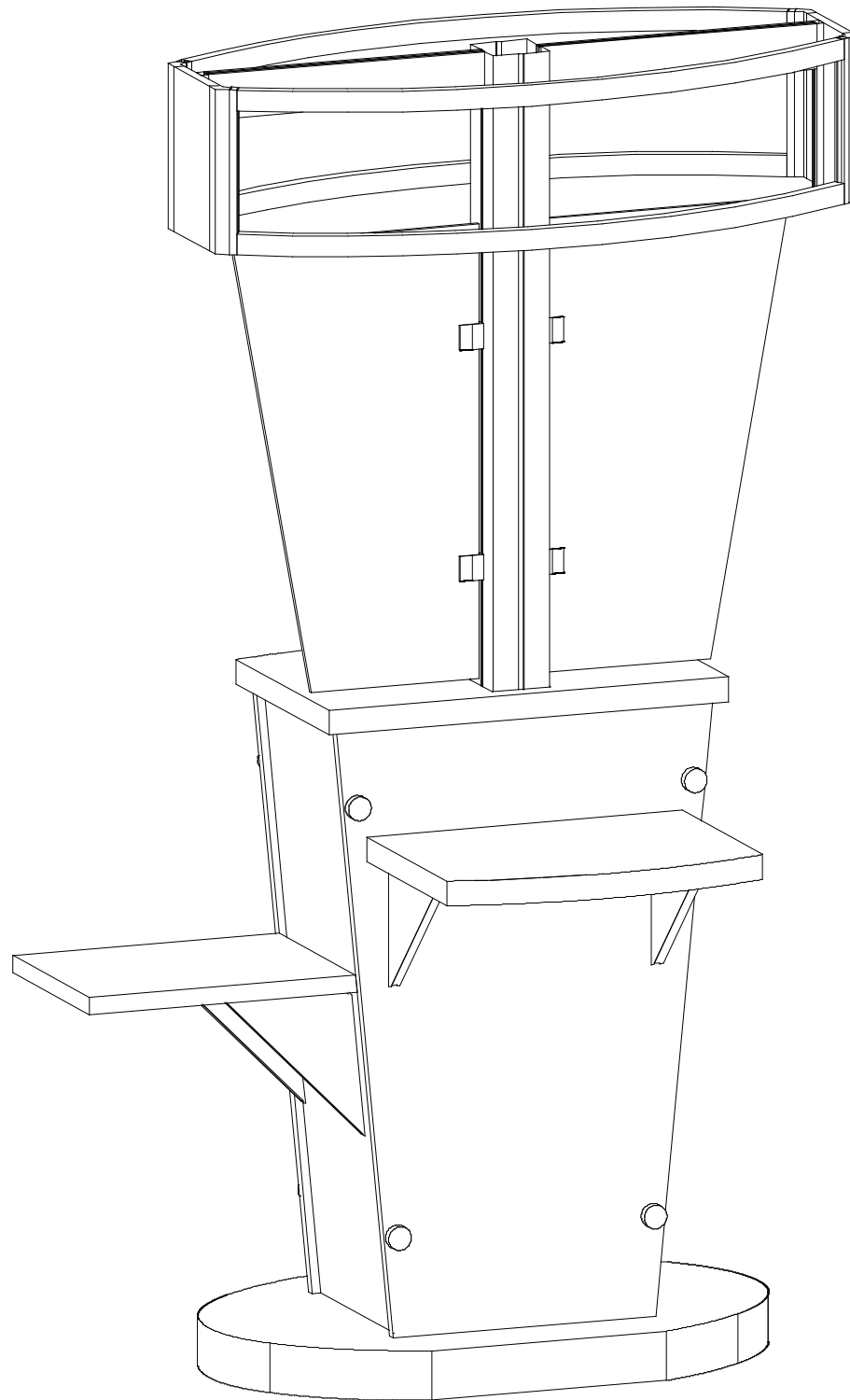

**WHEN DISASSEMBLING ALUMINUM EXTRUSION, TIGHTEN ALL SETSCREWS AND LOCKS TO PREVENT LOSS DURING SHIPPING**

# euro lt | HYBRIDS

## Using Your Setup Instructions

The Euro LT Hybrids Setup Instructions are created specifically for your configuration. They are laid out sequentially in levels, including exploded views, and a logical series of detailed steps to assemble the main structure and components. We encourage you to study the instructions **before** attempting to assemble your exhibit.

Each page reminds you to tighten the setscrews after disassembling your exhibit to prevent loss of the locks and setscrews (see below in RED). This is VERY IMPORTANT.

## Cleaning and Packing Your Display

- 1) Use care when cleaning aluminum extrusion or acrylic inserts. Use only non-abrasive cleaners.
- 2) When cleaning laminate inserts, countertops, or panels use mild cleansers and a soft material such as cotton.
- 3) Keep all display components away from extreme heat and long exposure to sunlight to avoid warping and fading.
- 4) Retain all packing material. It will make re-packing much easier and will reduce the likelihood of shipping damage.

## General Setup Instructions for Extrusion System



The Tool

Most exhibits can be assembled with the supplied Hex Key Tool. Occasionally, a flat head screwdriver may be required.



Typical Connection

Most horizontal extrusion connections have a patented expandable lock. This lock inserts into the groove of an opposing extrusion. Tightening the lock with the Hex Key Tool expands the lock and creates a strong positive connection.



Typical Connection (cont'd)

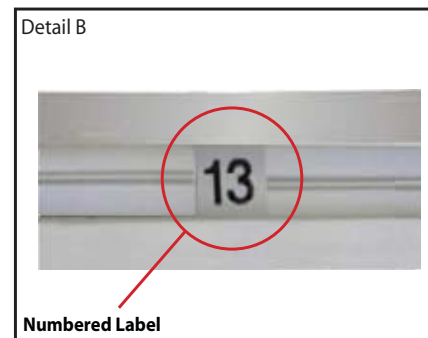

Numbered Label

Each extrusion contains a numbered label which corresponds with setup instructions. The label is located within a groove of the extrusion (when possible). With extrusion components the labels contain Black numbers unless otherwise specified.

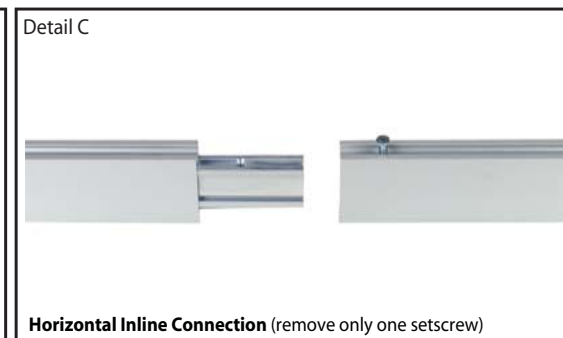

Horizontal Inline Connection (remove only one setscrew)

Remove only (1) setscrew when disassembling. Replace setscrew in extrusion after assembling it. Before packing, replace setscrew in extrusion to avoid losing it.

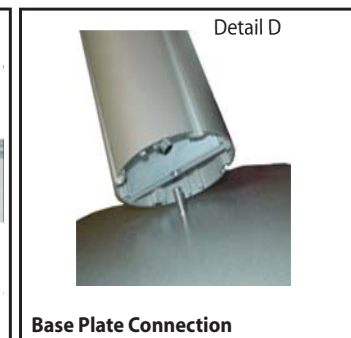

Base Plate Connection

Attach base plate to round or square vertical extrusion using the bolt provided. Be careful not to strip the threads.

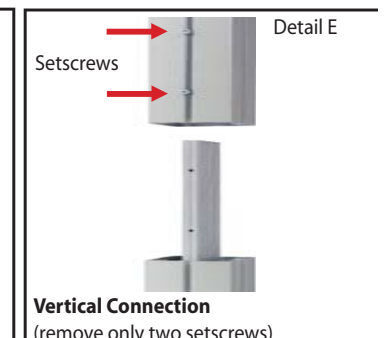

Vertical Connection (remove only two setscrews)

When vertical extrusions are packed in portable cases rather than crates or tubs, they must be broken down into smaller section which then require assembly.

Remove only (2) setscrews when disassembling. Replace setscrews in extrusion after assembling it. Before packing, replace setscrews in extrusion to avoid losing them.

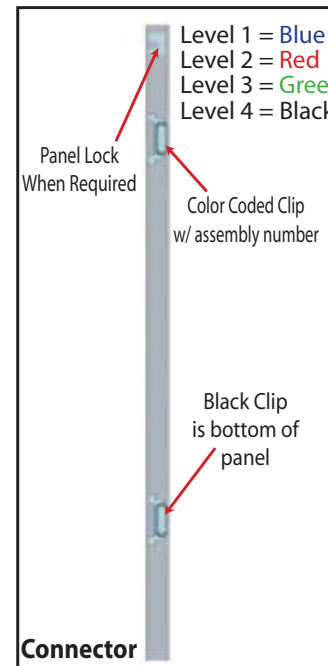

Connector

Each component has 2 clips, the lower clip is ALWAYS black. The top clip is color coded to distinguish which level. The color coded clip also contains the numbered label.

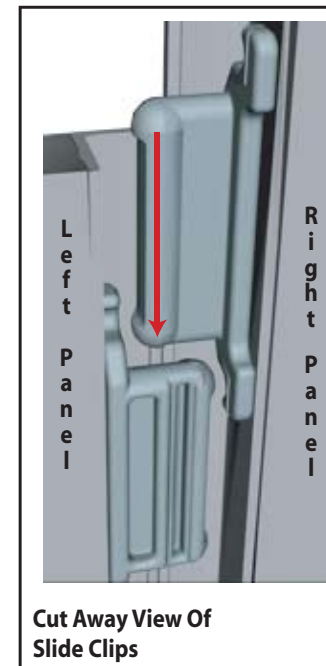

Cut Away View Of Slide Clips

Components connect together by aligning them and sliding downward connecting clips together.

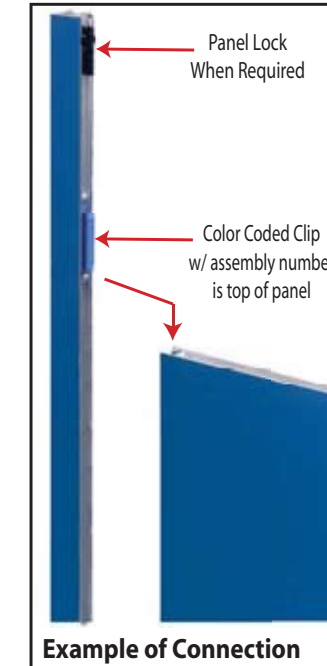

Example of Connection

Configurations are assembled from left to right, usually starting with #1 and following the numbered sequence.

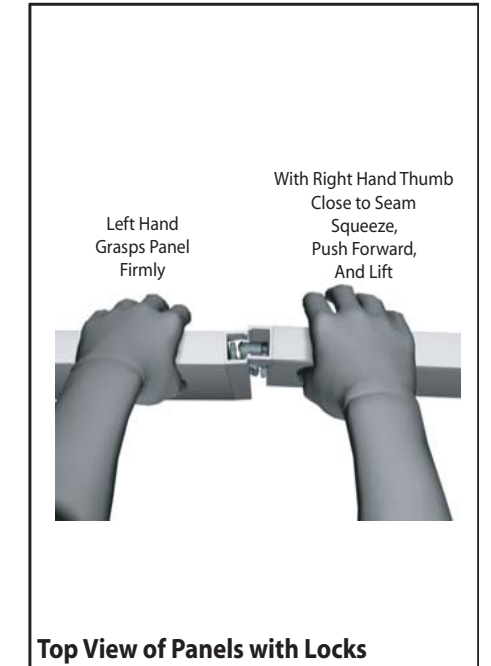

Top View of Panels with Locks

The first level of components contain panel locks that are located at the top of the panel for extra stability and seamless connection. When disassembling panels twist top connection slightly and lift right panel upward.

**WHEN DISASSEMBLING ALUMINUM EXTRUSION, TIGHTEN ALL SETSCREWS AND LOCKS TO PREVENT LOSS DURING SHIPPING**

866.652.2100

Setup Instructions:

- A) Place Square Vertical extrusion [1] atop holes located on base and secure using bolt provided.
- B) Assemble Pedestal atop Base using standoff screws to secure the front panel with door and back panel of the pedestal to the side panels.
- C) After assembling front, back, and side panels, attach the shelf supports with Velcro on the inside of panels then place internal shelf. Place Counter atop Vertical post resting on assembled base, secure counter to Vertical post using thumbscrews provided.

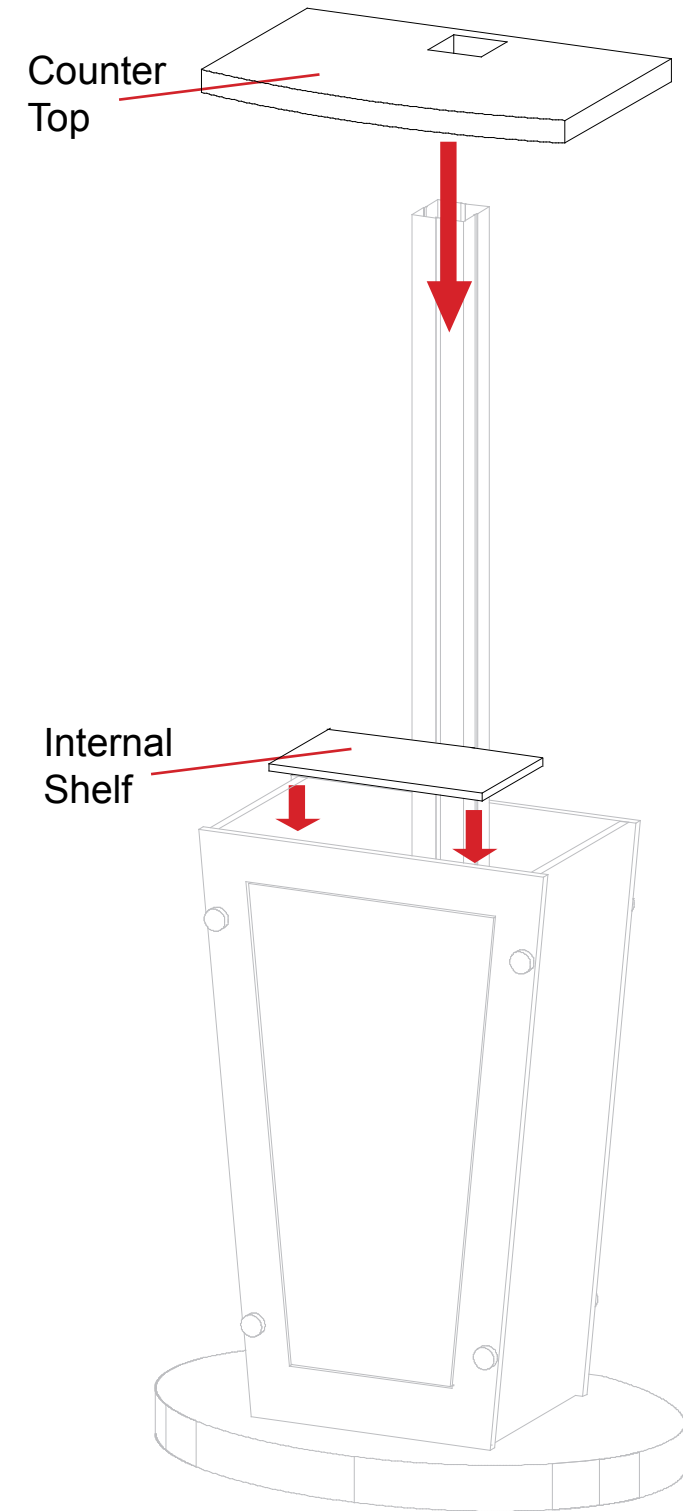
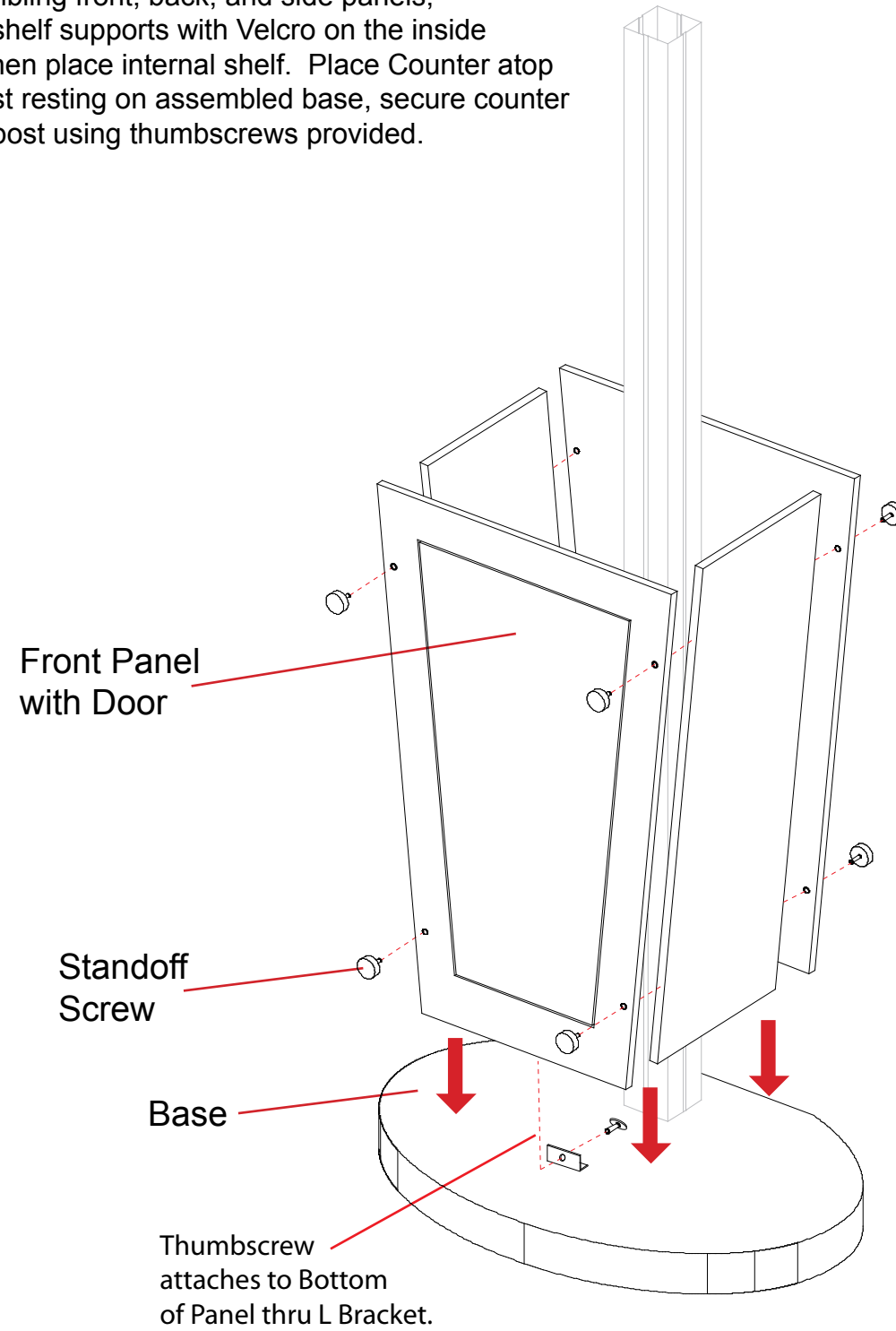
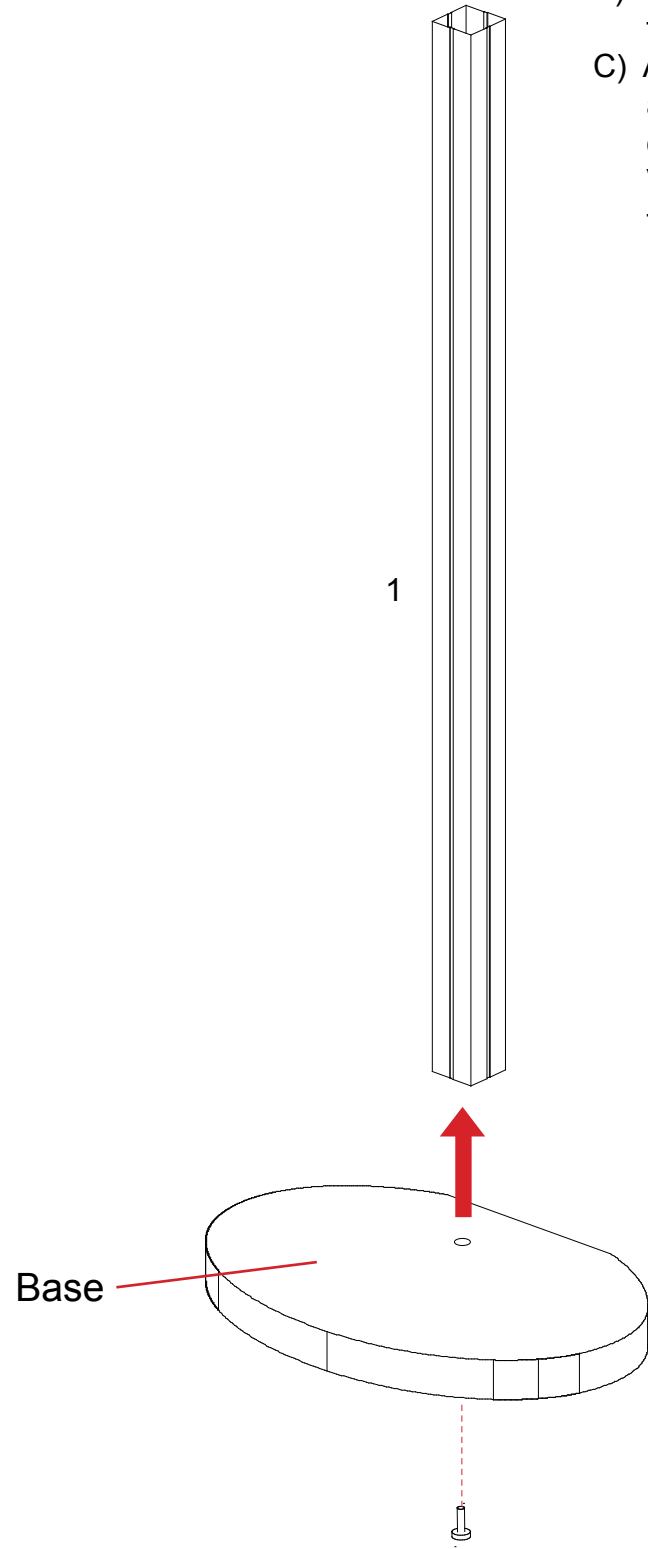

**WHEN DISASSEMBLING ALUMINUM EXTRUSION, TIGHTEN ALL SETSCREWS AND LOCKS TO PREVENT LOSS DURING SHIPPING**

866.652.2100

Item	Qty.	Description
2	2	38.4911" Curved Horizontal Extrusion
3	2	38.4911" Curved Horizontal Extrusion
4	2	Assembled Side Panel
5	2	17.477"h Horizontal Extrusion
6	2	Angled Shelf Support
7	2	Angled Shelf Support

Steps:

- 1) Connect angled shelf supports [6 and 7] to pedestal base as shown at right.
- 2) Place shelves atop supports and secure to base using hardware provided.
- 3) Attach wings according to detail.
- 4) Connect curved horizontal extrusions [2 and 3] between side panel assemblies [4] as shown.
- 5) Connect horizontal extrusions [5] between panel assemblies [4] making sure that grooves on extrusions [5] face up.
- 6) Connect assembled header piece to square vertical extrusion [1].

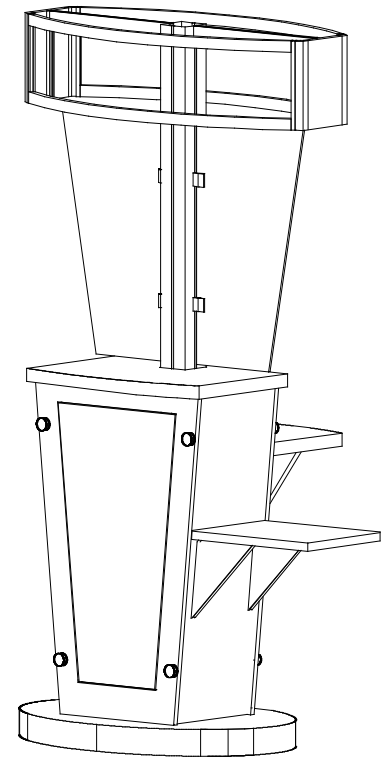
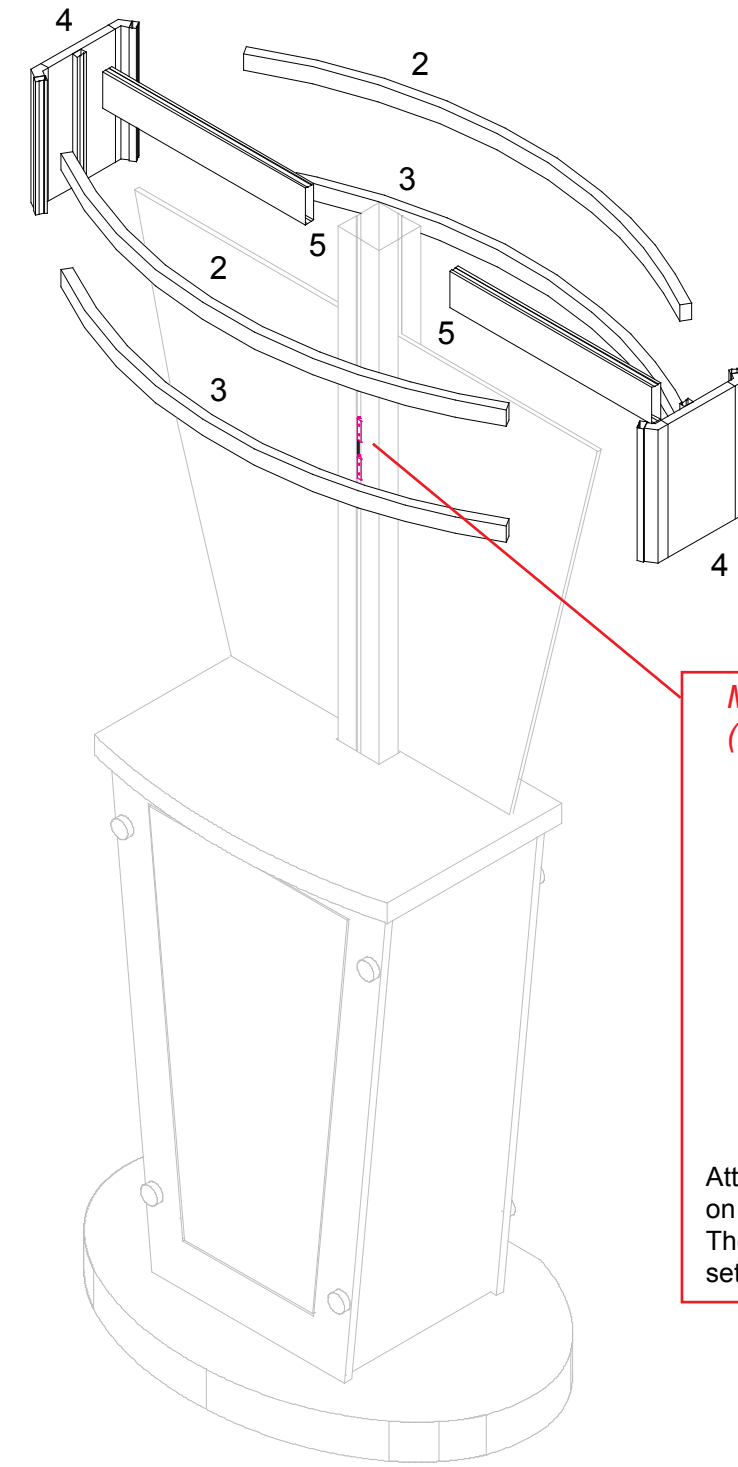
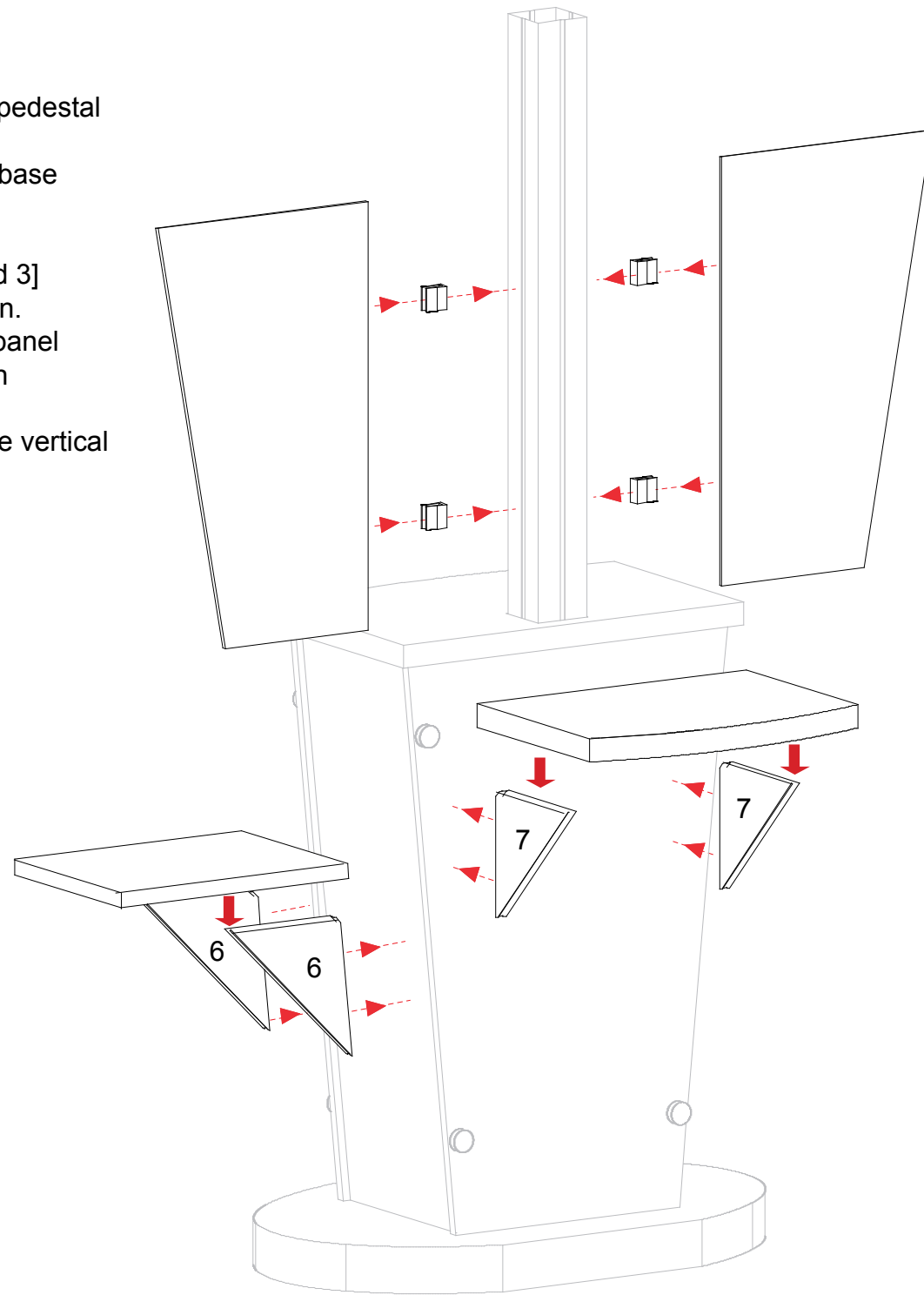

**Wing Attachment**

Slide A10 Clamp into groove of square extrusion.

A10

When desired location is found, tighten set screw to secure.

Set-Screw

Tighten black plastic set screw to secure Wing in place.

Black Plastic Set-screw

**Monitor Mount Attachment (both sides)**

Attach back plate to connectors on vertical extrusion using screws. Then attach top plate and tighten setscrews to secure.

**WHEN DISASSEMBLING ALUMINUM EXTRUSION, TIGHTEN ALL SETSCREWS AND LOCKS TO PREVENT LOSS DURING SHIPPING**