

Plan View

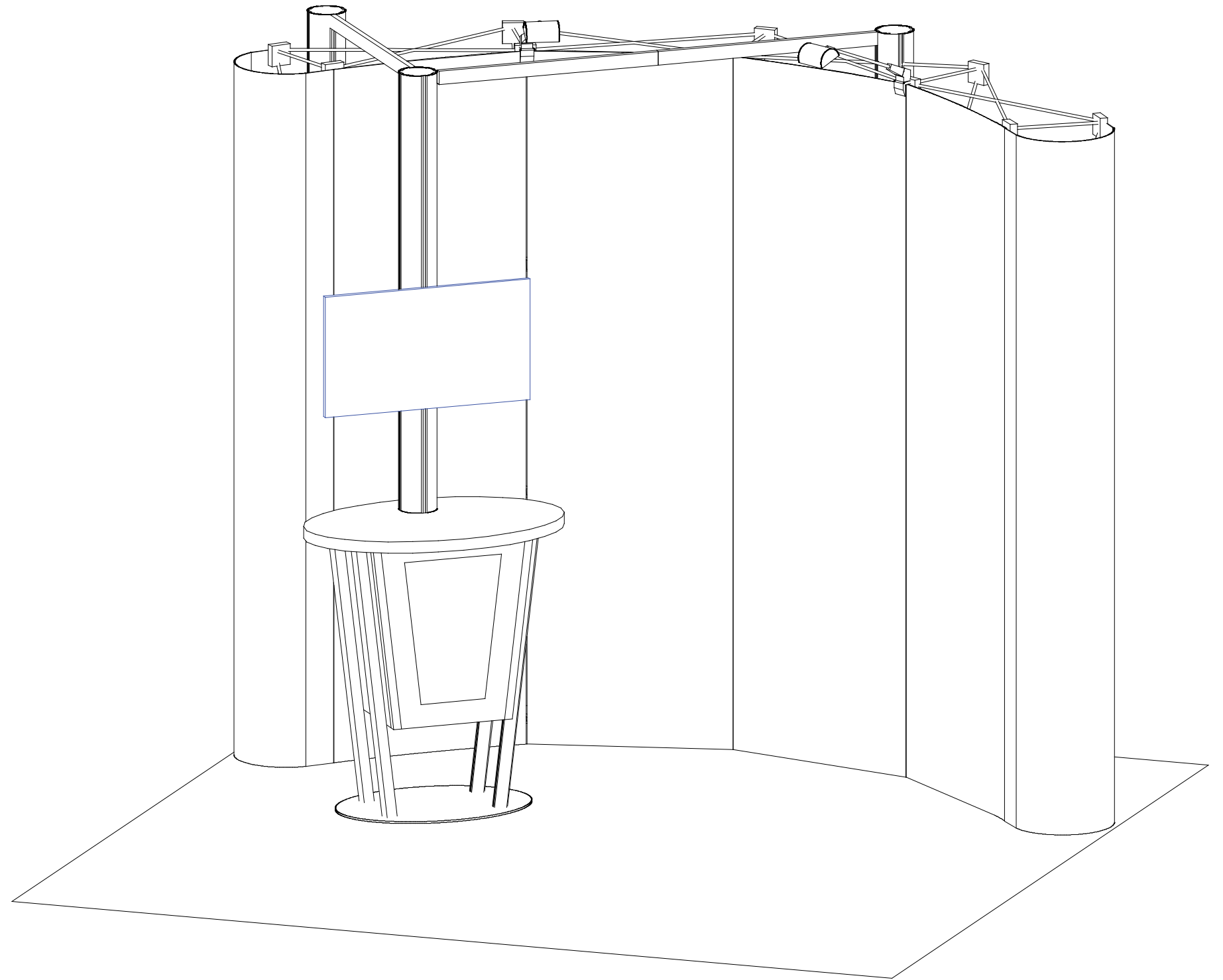

WHEN DISASSEMBLING ALUMINUM EXTRUSION, TIGHTEN ALL SETSCREWS AND LOCKS TO PREVENT LOSS DURING SHIPPING

visionary™ IDESIGNS

Using Your Setup Instructions

The Visionary Designs Setup Instructions are created specifically for your configuration. They are laid out sequentially, including an exploded view of the entire display, and then a logical series of detailed steps to assemble the main structure and components. We encourage you to study the instructions **before** attempting to assemble your exhibit.

Each page reminds you to tighten the setscrews after disassembling your exhibit to prevent loss of the locks and setscrews (see below in RED). This is **VERY IMPORTANT**.

Cleaning and Packing Your Display

- 1) Use care when cleaning aluminum extrusion or acrylic inserts. Use only non-abrasive cleaners.
- 2) When cleaning laminate inserts or countertops, use mild cleansers and a soft material such as cotton.
- 3) Keep all display components away from extreme heat and long exposure to sunlight to avoid warping and fading.
- 4) Retain all packing material. It will make re-packing much easier and will reduce the likelihood of shipping damage.



The Tool

Most Visionary Designs exhibits can be assembled with the supplied Hex Key Tool. Occasionally, a flat head screwdriver may be required.



Detail A

Typical Connection



Typical Connection (cont'd)

Most horizontal extrusion connections have a patented expandable lock. This lock inserts into the groove of an opposing extrusion. Tightening the lock with the Hex Key Tool expands the lock and creates a strong positive connection.



Detail B

Numbered Label

Each extrusion contains a numbered label which corresponds with setup instructions. The label is located within a groove of the extrusion (when possible). With Visionary Designs the labels contain Black numbers unless otherwise specified.



Detail C

Horizontal Inline Connection (remove only one setscrew)

Remove only (1) setscrew when disassembling. Replace setscrew in extrusion after assembling it. Before packing, replace setscrew in extrusion to avoid losing it.



Detail D

Base Plate Connection

Attach base plate to round or square vertical extrusion using the bolt provided. Be careful not to strip the threads.

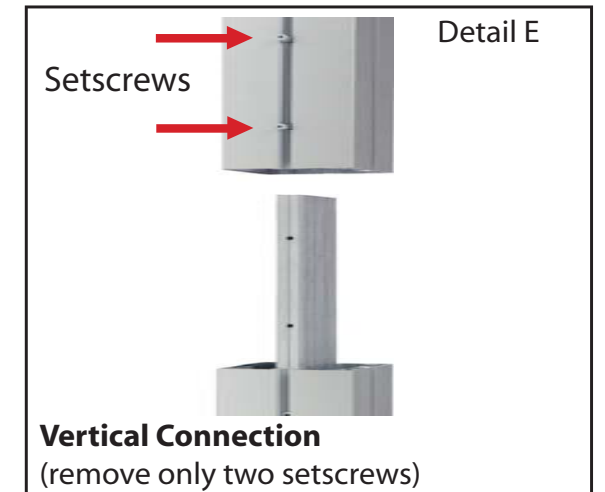

Detail E

Vertical Connection
(remove only two setscrews)

When vertical extrusions are packed in portable cases rather than crates or tubs, they must be broken down into smaller sections which then require assembly.

Remove only (2) setscrews when disassembling. Replace setscrews in extrusion after assembling it. Before packing, replace setscrews in extrusion to avoid losing them.

WHEN DISASSEMBLING ALUMINUM EXTRUSION, TIGHTEN ALL SETSCREWS AND LOCKS TO PREVENT LOSS DURING SHIPPING

866.652.2100

Modul Extrusion: Part List

Item	Qty.	Description
1	1	Base Plate
2	2	Right Leg Extrusion
3	2	Left Leg Extrusion
4/4A	1	Vertical Extrusion for Monitor Mount Attachment

EURO LT System: Part List

Item	Qty.	Description
1	1	Tapered Panel w/ Door
2	1	Side Panel
3	1	Tapered Panel
4	1	Side Panel

Steps:

- 1) Attach left leg extrusions [3] to panel [2] and right leg extrusions [2] to panel [4] using supplied screws, see detail illustration below.
- 2) Attach leg assemblies to base plate [1] using bolts as shown.

Steps (Cont'd):

- 3) Assemble panels [1 and 3] to panels [2 and 3] as shown.
- 4) Attach pins to back of panels [1 and 3], then set floor atop pins.
- 5) Velcro shelf supports to inside of assembled base, then set shelf atop supports.
- 6) Attach vertical extrusion [4 and 4a] to counter using supplied bolt.
- 7) Set assembled counter atop assembled base.
- 8) Attach monitor mount to vertical extrusion where indicated, see monitor mount attachment detail.

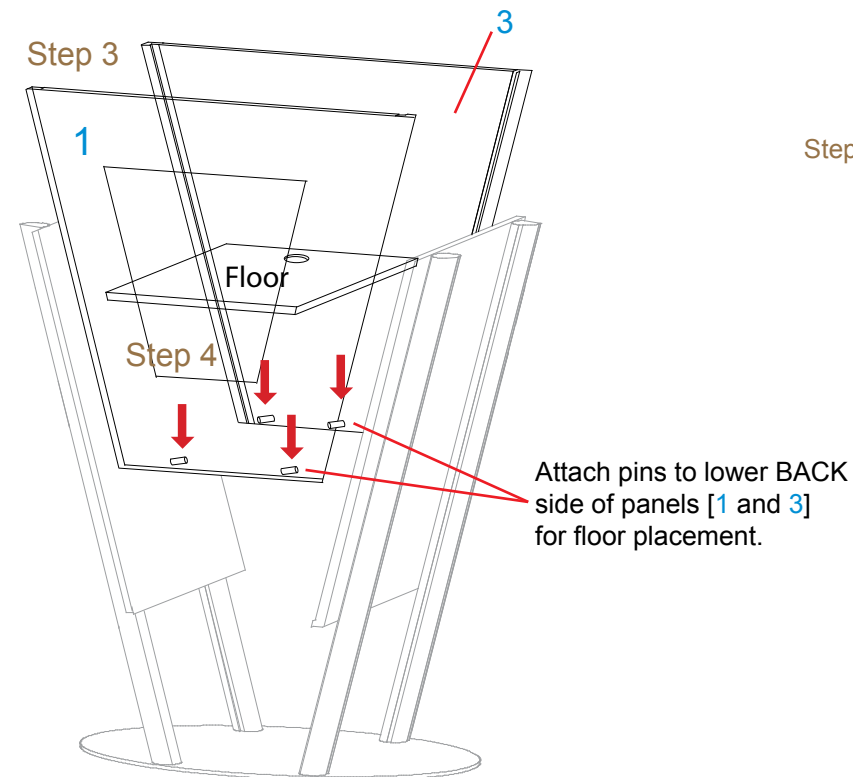
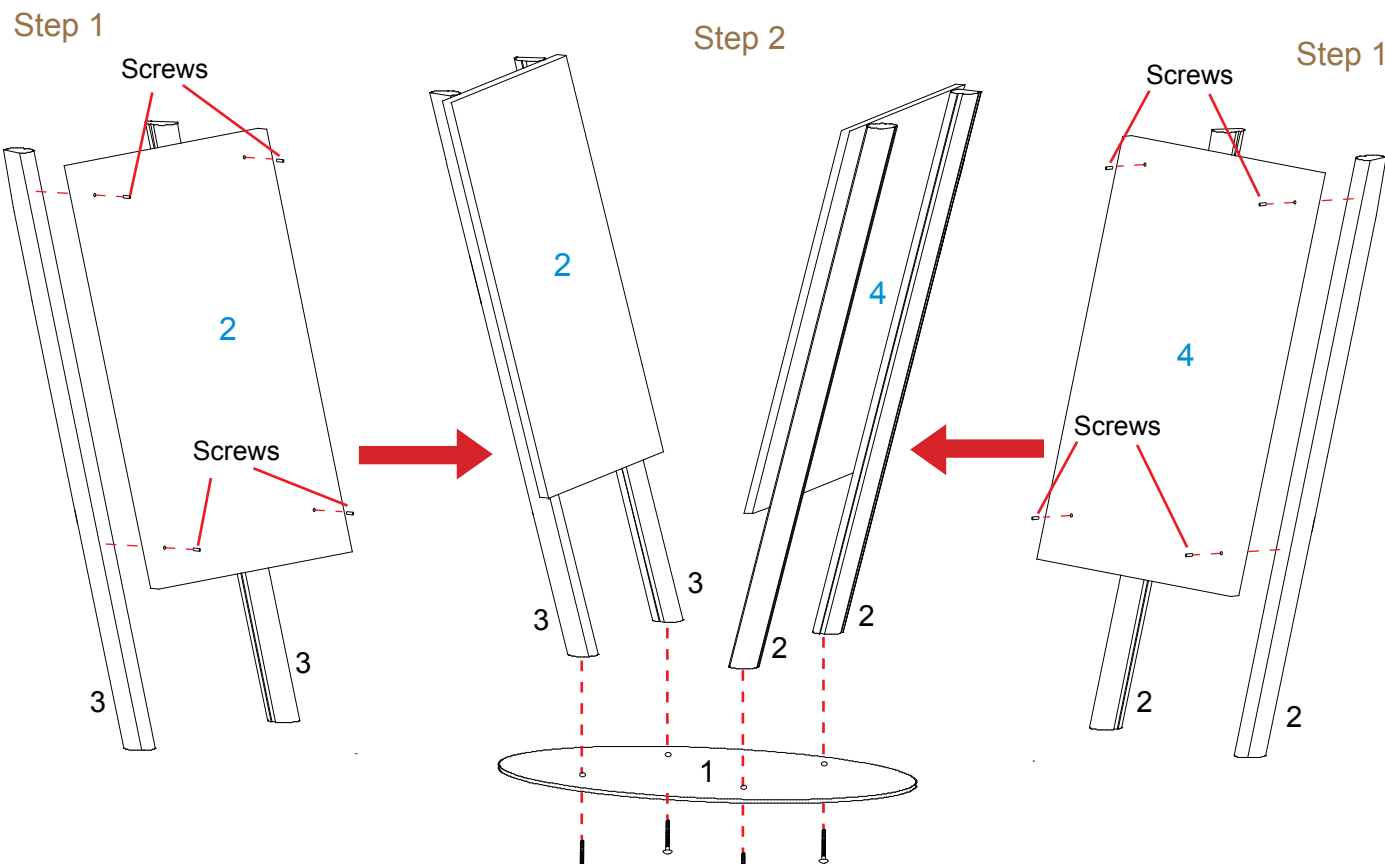
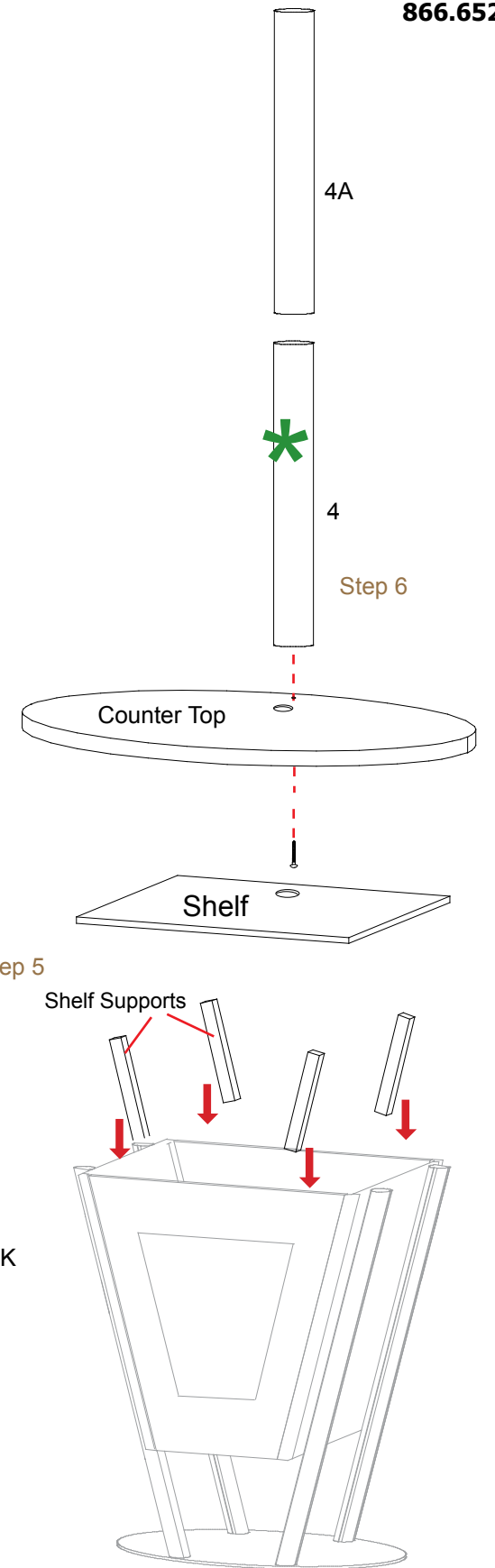
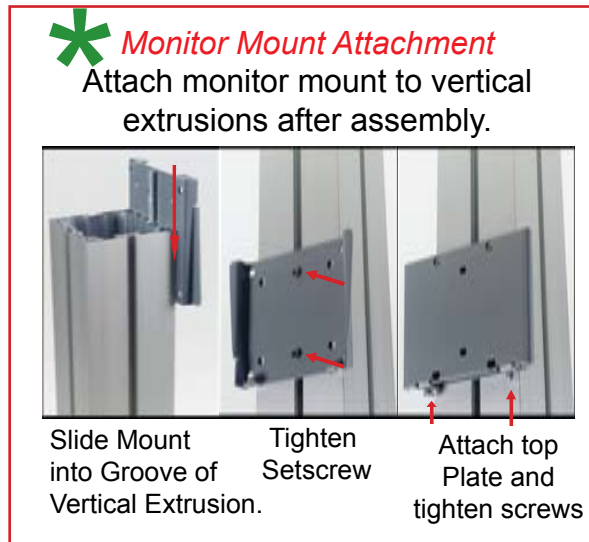

WHEN DISASSEMBLING ALUMINUM EXTRUSION, TIGHTEN ALL SETSCREWS AND LOCKS TO PREVENT LOSS DURING SHIPPING

866.652.2100

Part Number	Qty for Step	Description
5	2	Base Plates
6	2	47.75" h Lower Vertical extrusion
7	2	48" h Upper Vertical extrusion
8	1	30" w Horizontal extrusion
9	1	30" w Horizontal extrusion
10	1	30" w Horizontal extrusion

Steps

- 1) Attach 48" h Vertical extrusions [7] to 47.75" vertical extrusions [6] as shown.
- 2) Attach assembled verticals to base plates [5], refer to General Info page, Detail D.
- 3) Connect horizontal extrusion [9 to 10].
- 4) Attach assembled extrusions [9/10 and 8] between verticals [7 and 4A from previous page].

 **Monitor Mount Attachment**

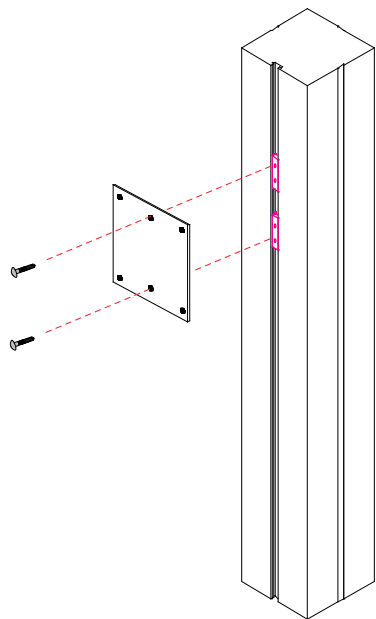

Attach back plate to connectors on vertical extrusion using screws. Then attach top plate and tighten setscrews to secure.

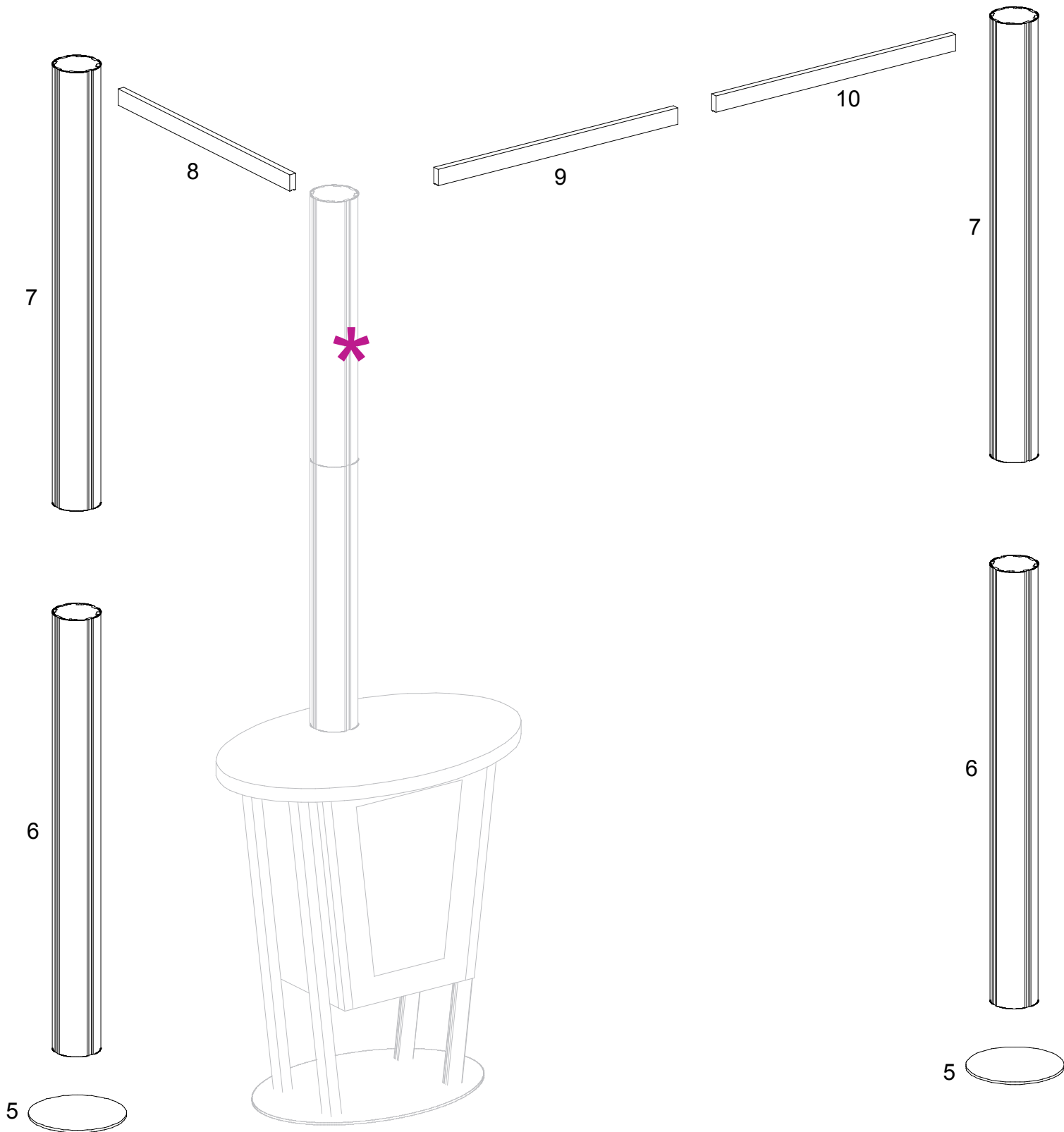

WHEN DISASSEMBLING ALUMINUM EXTRUSION, TIGHTEN ALL SETSCREWS AND LOCKS TO PREVENT LOSS DURING SHIPPING

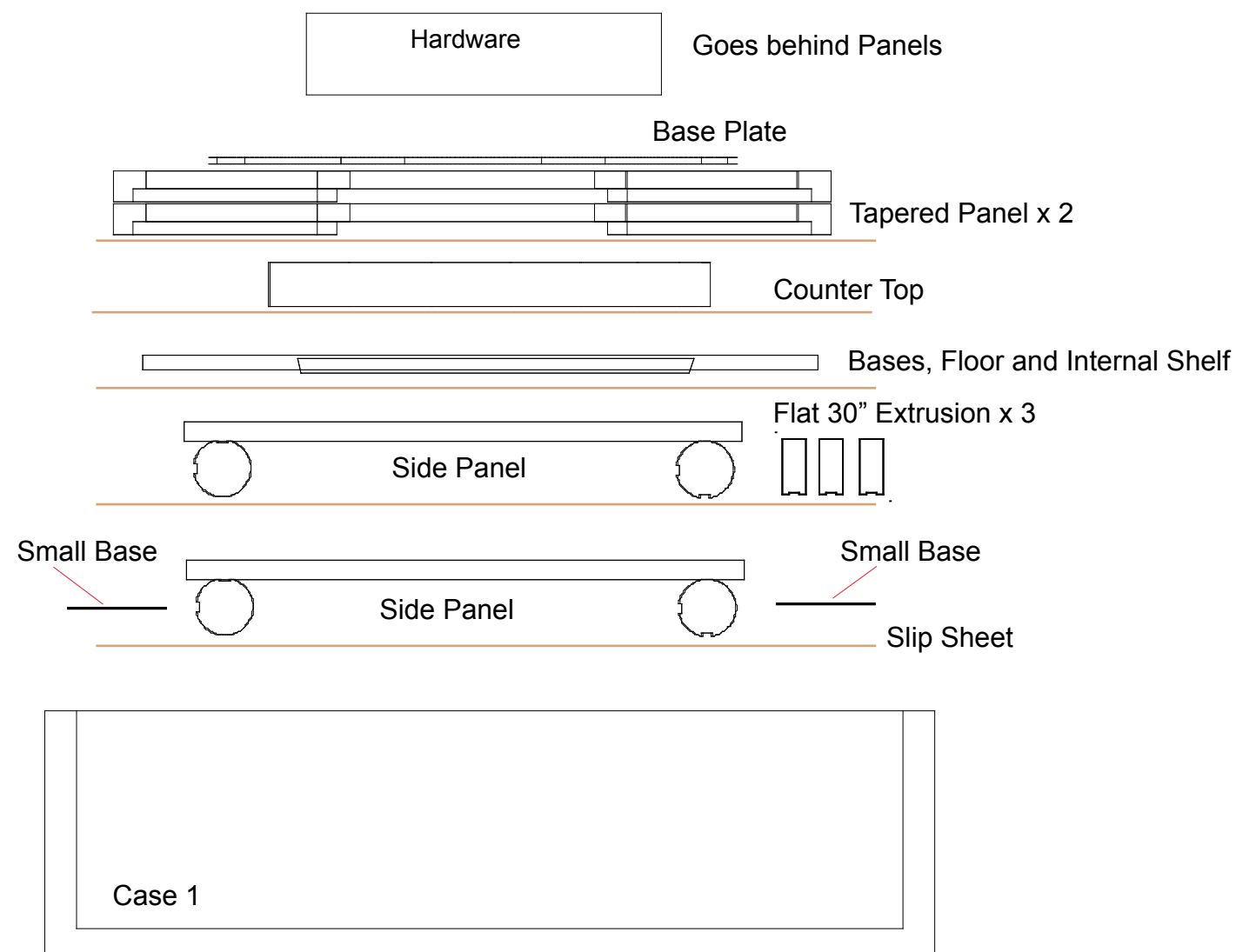

WHEN DISASSEMBLING ALUMINUM EXTRUSION, TIGHTEN ALL SETSCREWS AND LOCKS TO PREVENT LOSS DURING SHIPPING

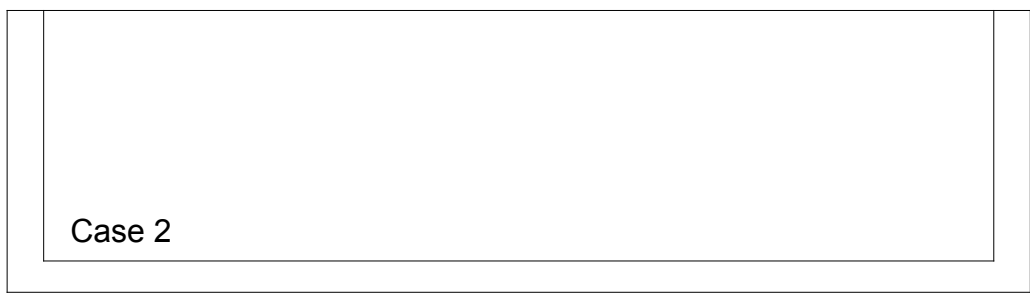
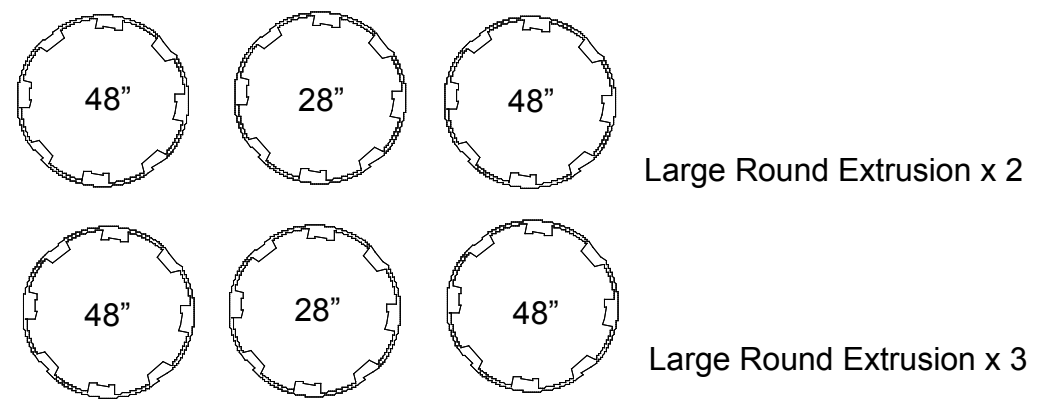

WHEN DISASSEMBLING ALUMINUM EXTRUSION, TIGHTEN ALL SETSCREWS AND LOCKS TO PREVENT LOSS DURING SHIPPING