

20'

20'

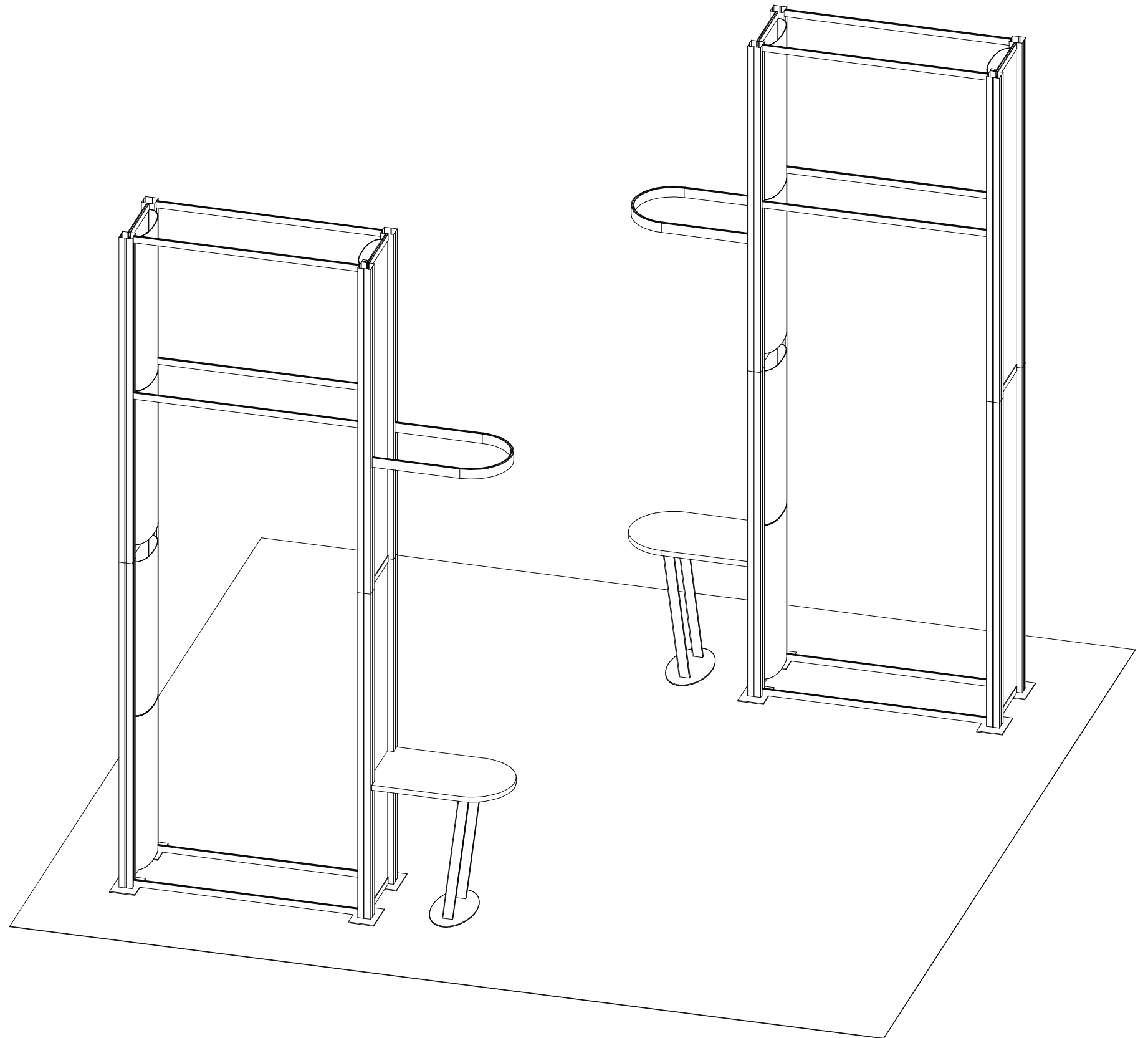

WHEN DISASSEMBLING ALUMINUM EXTRUSION, TIGHTEN ALL SETSCREWS AND LOCKS TO PREVENT LOSS DURING SHIPPING

# visionary™ IDESIGNS

## Using Your Setup Instructions

The Visionary Designs Setup Instructions are created specifically for your configuration. They are laid out sequentially, including an exploded view of the entire display, and then a logical series of detailed steps to assemble the main structure and components. We encourage you to study the instructions **before** attempting to assemble your exhibit.

Each page reminds you to tighten the setscrews after disassembling your exhibit to prevent loss of the locks and setscrews (see below in RED). This is **VERY IMPORTANT**.

## Cleaning and Packing Your Display

- 1) Use care when cleaning aluminum extrusion or acrylic inserts. Use only non-abrasive cleaners.
- 2) When cleaning laminate inserts or countertops, use mild cleansers and a soft material such as cotton.
- 3) Keep all display components away from extreme heat and long exposure to sunlight to avoid warping and fading.
- 4) Retain all packing material. It will make re-packing much easier and will reduce the likelihood of shipping damage.



**The Tool**

Most Visionary Designs exhibits can be assembled with the supplied Hex Key Tool. Occasionally, a flat head screwdriver may be required.



Detail A

**Typical Connection**



**Typical Connection (cont'd)**

Most horizontal extrusion connections have a patented expandable lock. This lock inserts into the groove of an opposing extrusion. Tightening the lock with the Hex Key Tool expands the lock and creates a strong positive connection.



Detail B

**Numbered Label**

Each extrusion contains a numbered label which corresponds with setup instructions. The label is located within a groove of the extrusion (when possible). With Visionary Designs the labels contain Black numbers unless otherwise specified.



Detail C

**Horizontal Inline Connection** (remove only one setscrew)

Remove only (1) setscrew when disassembling. Replace setscrew in extrusion after assembling it. Before packing, replace setscrew in extrusion to avoid losing it.

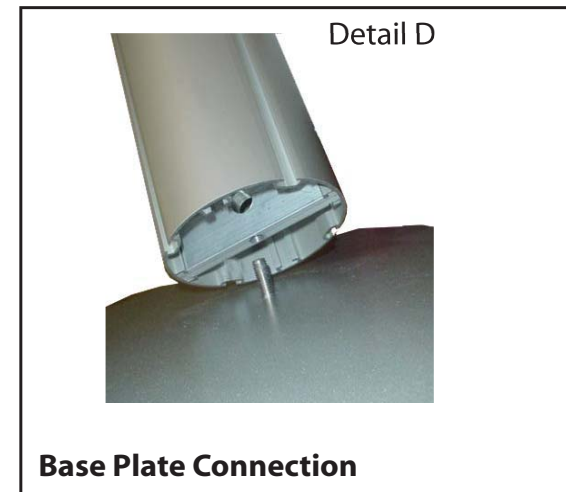

Detail D

**Base Plate Connection**

Attach base plate to round or square vertical extrusion using the bolt provided. Be careful not to strip the threads.



Detail E

**Vertical Connection**  
(remove only two setscrews)

When vertical extrusions are packed in portable cases rather than crates or tubs, they must be broken down into smaller sections which then require assembly.

Remove only (2) setscrews when disassembling. Replace setscrews in extrusion after assembling it. Before packing, replace setscrews in extrusion to avoid losing them.

**WHEN DISASSEMBLING ALUMINUM EXTRUSION, TIGHTEN ALL SETSCREWS AND LOCKS TO PREVENT LOSS DURING SHIPPING**

Item	Qty	Description
1	4	Square Base Plate
2	1	96" h Lower Vertical Extrusion
3	1	96" h Lower Vertical Extrusion
4	1	96" h Lower Vertical Extrusion
5	1	96" h Lower Vertical Extrusion
6	1	96" h Upper Vertical Extrusion
7	1	96" h Upper Vertical Extrusion
8	1	96" h Upper Vertical Extrusion
9	1	96" h Upper Vertical Extrusion
10	1	18" w Horizontal Extrusion
11	1	18" w Horizontal Extrusion

Steps:

- 1) Attach lower vertical extrusions [2, 3, 4 and 5] to base plates [1].
- 2) Attach upper vertical extrusions to lower vertical extrusions.
- 3) Connect horizontal extrusions between vertical assemblies, placing Plex panels where indicated.
- 4) Repeat steps for second unit.

**Note:** Velcro Strips must be on inside behind Plex panels

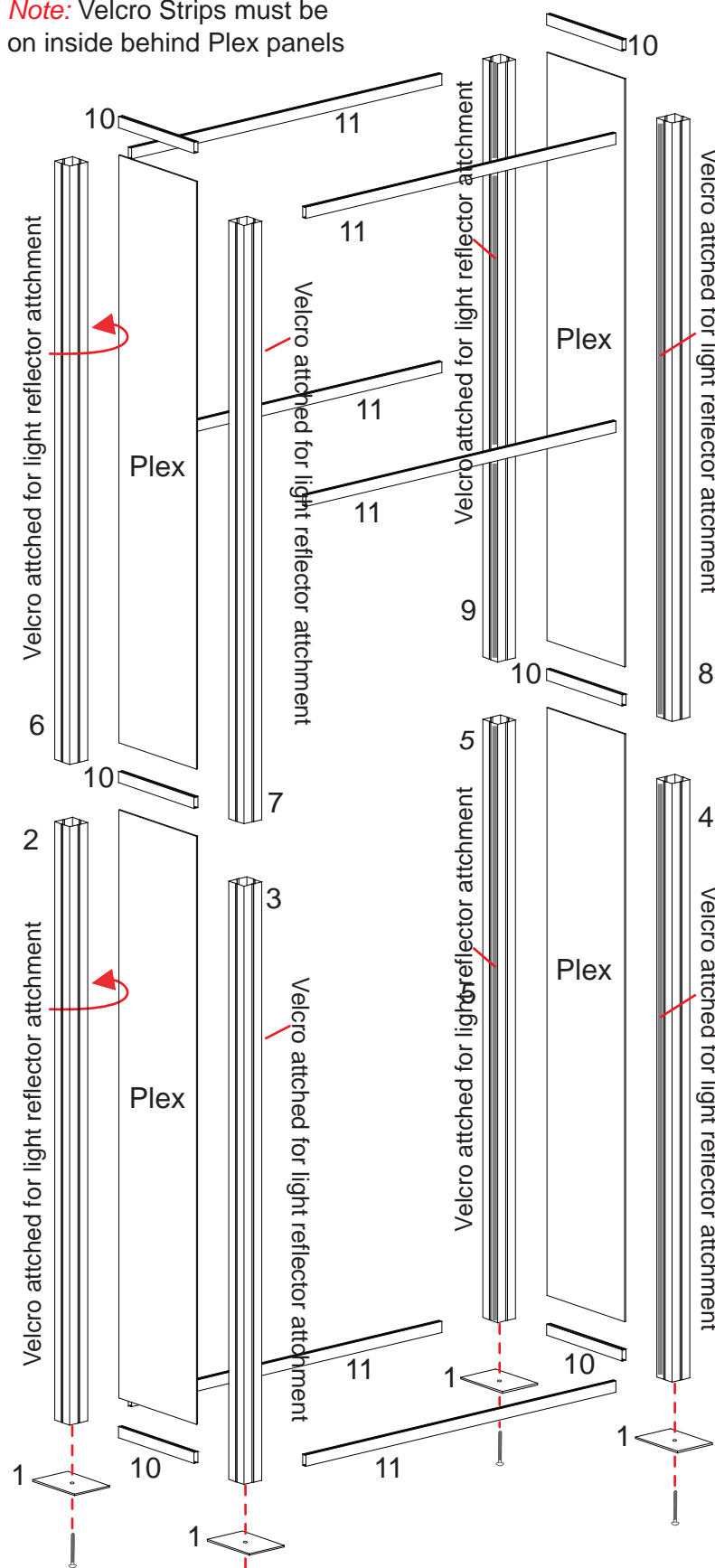

866.652.2100

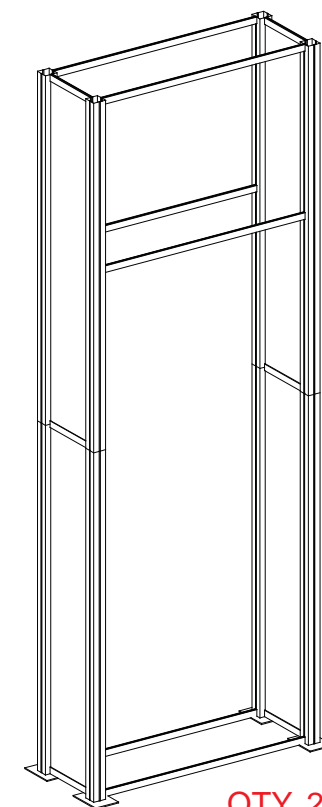

QTY. 2

**WHEN DISASSEMBLING ALUMINUM EXTRUSION, TIGHTEN ALL SETSCREWS AND LOCKS TO PREVENT LOSS DURING SHIPPING**

Item	Qty	Description
12	1	Oval Base Plate
13	1	Counter Support Extrusion
14	1	Counter Support Extrusion
15	1	24" w Horizontal Extrusion
16	1	24" w Horizontal Extrusion
17	1	Half Curve Extrusion

Steps:

- 1) Attach counter supports [13 and 14] to base plate [12].
- 2) Attach counter top to counter supports, see counter attachment details.
- 3) Attach extrusions [15 and 16] to half curve extrusion [17], then attach extrusion assembly to assembled tower at desired location.
- 4) Repeat steps for second unit.

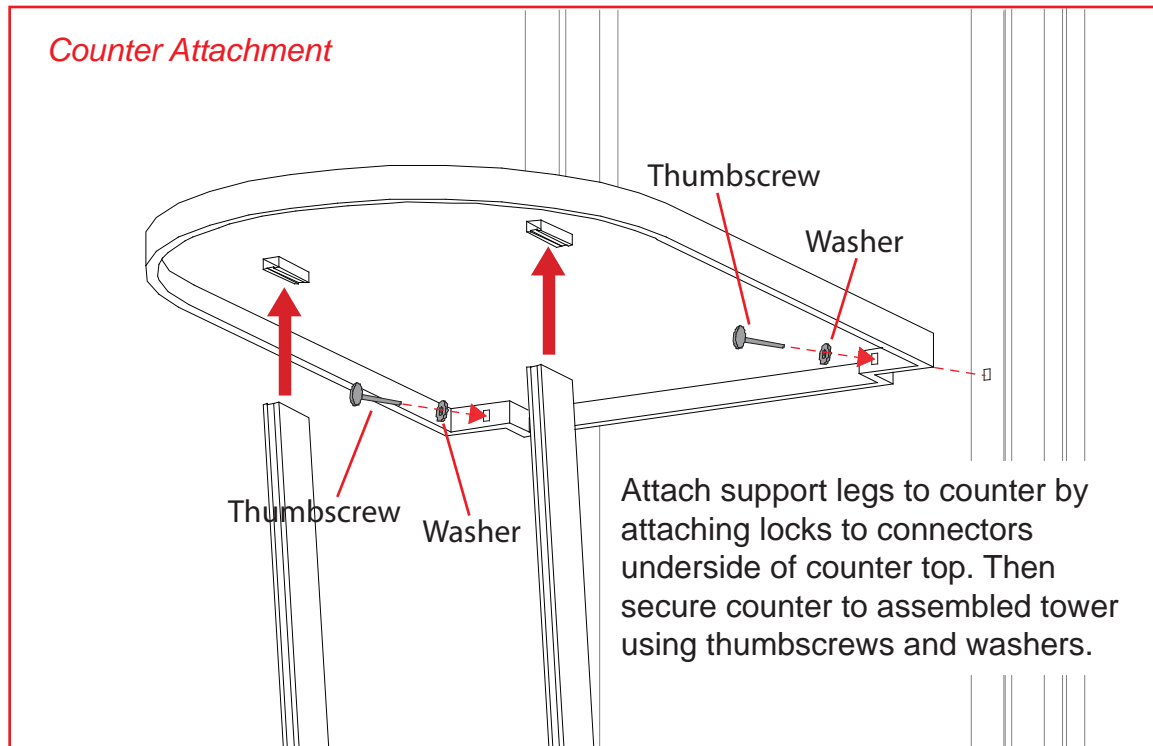
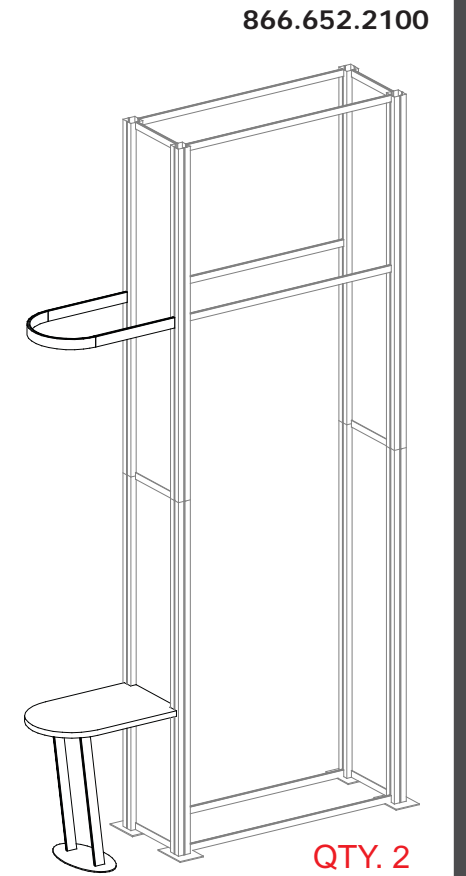
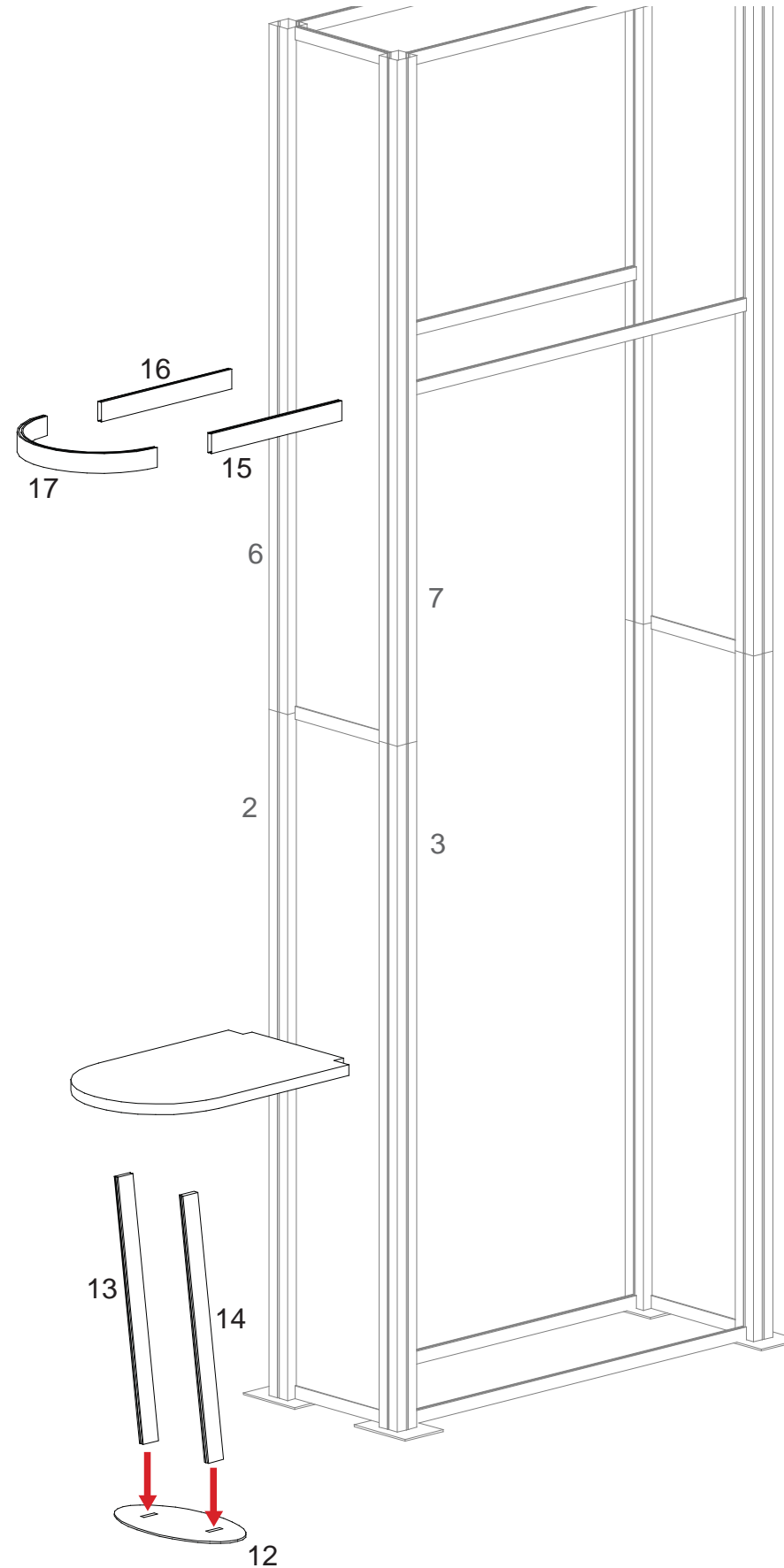

**WHEN DISASSEMBLING ALUMINUM EXTRUSION, TIGHTEN ALL SETSCREWS AND LOCKS TO PREVENT LOSS DURING SHIPPING**

Steps:

- 1) Attach light reflectors to assembled tower, see light reflector attachment details.

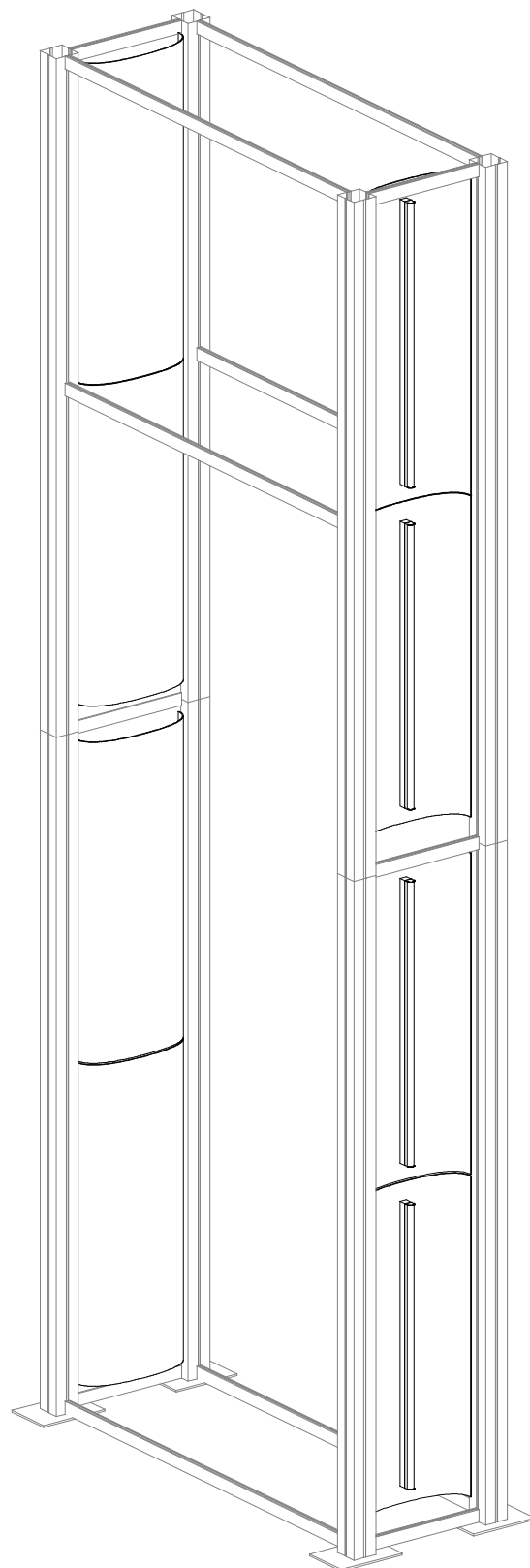

*Light Reflector Attachment*

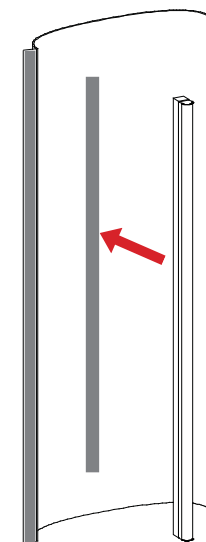

Attach fluorescent light to Velcro strip on light reflector.

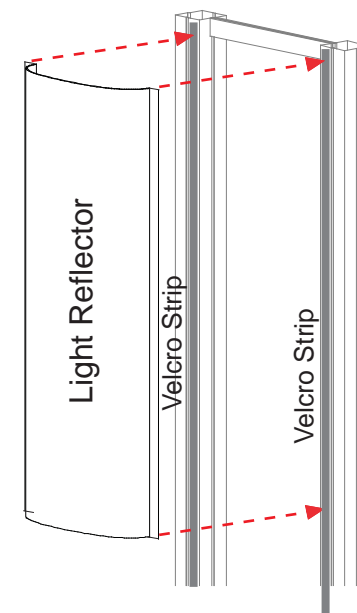

Then attach light reflector to Velcro on Uprights.

**WHEN DISASSEMBLING ALUMINUM EXTRUSION, TIGHTEN ALL SETSCREWS AND LOCKS TO PREVENT LOSS DURING SHIPPING**