

Perfect 10 Hybrid Displays

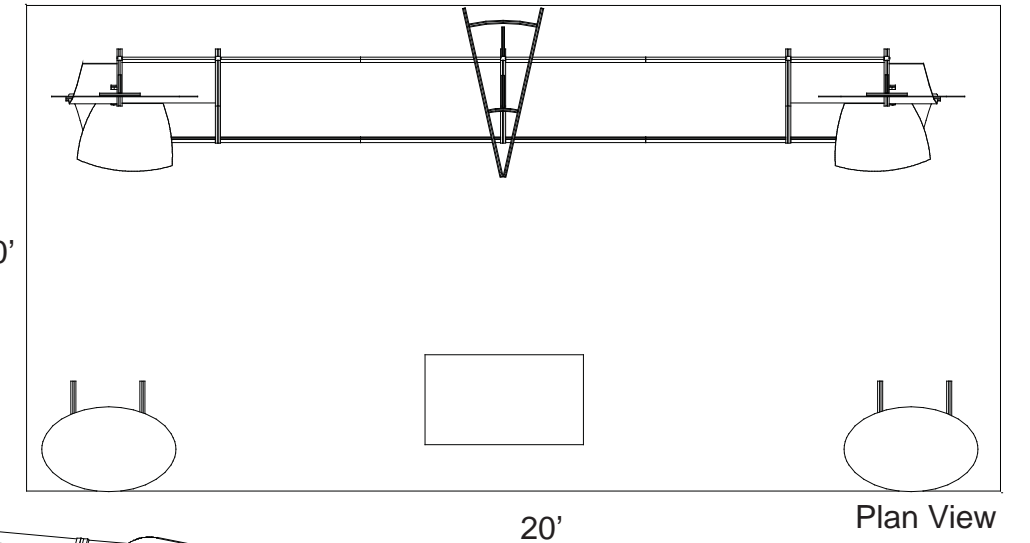
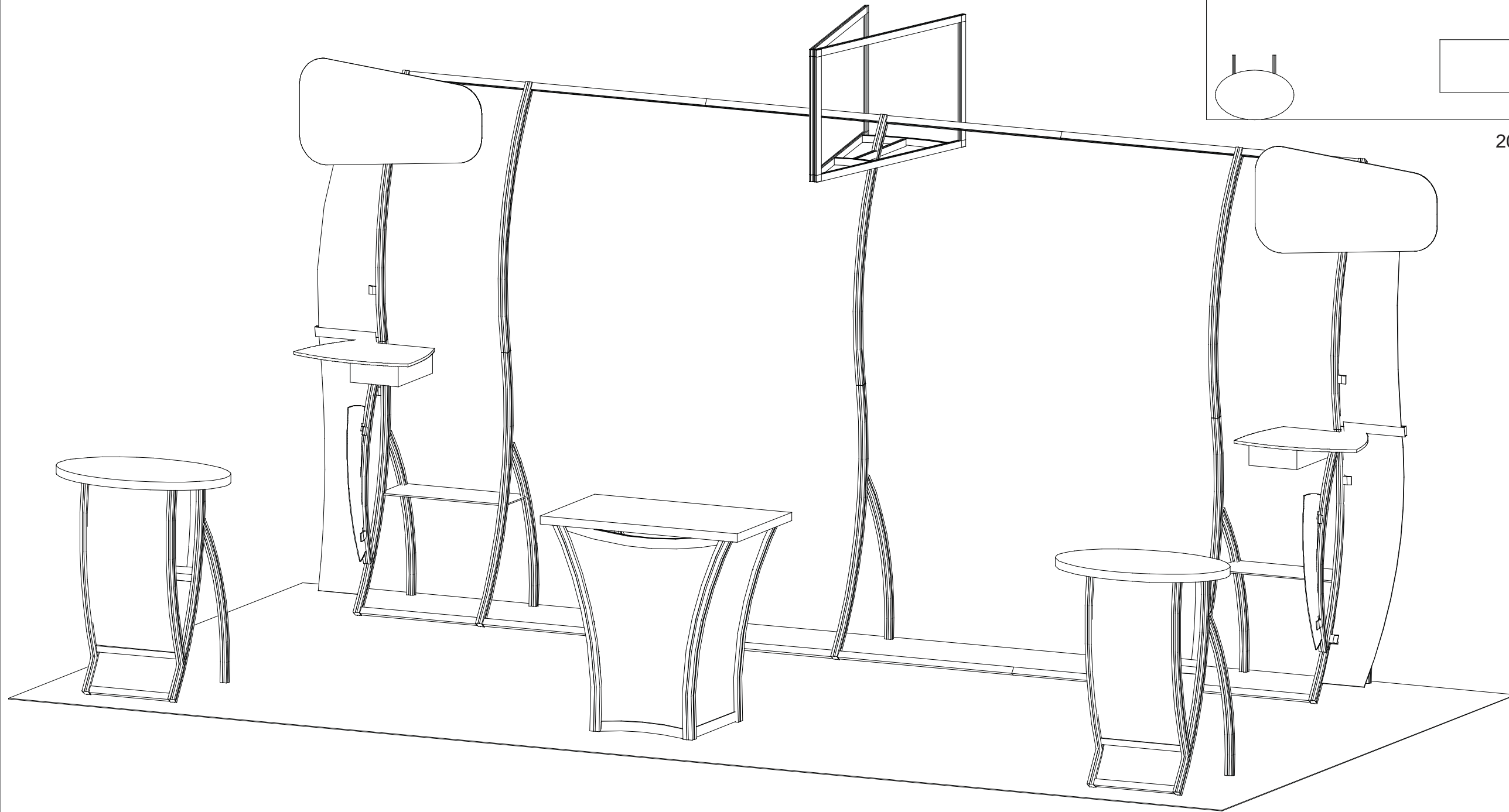

WHEN DISASSEMBLING TIGHTEN ALL BLACK KNOBS TO PREVENT LOSS DURING SHIPPING

866.652.2100

Part Number	Description
1	Left Leg Assembly w/ A10 Clamps Attached
2	Middle Leg Assembly
3A	Upper Curved Vertical w/ A10 Clamps Attached
3	Upper Curved Vertical
4	23" w Horizontal

NOTE: When assembling horizontals they should be placed approximately one inch from TOP and BOTTOM.

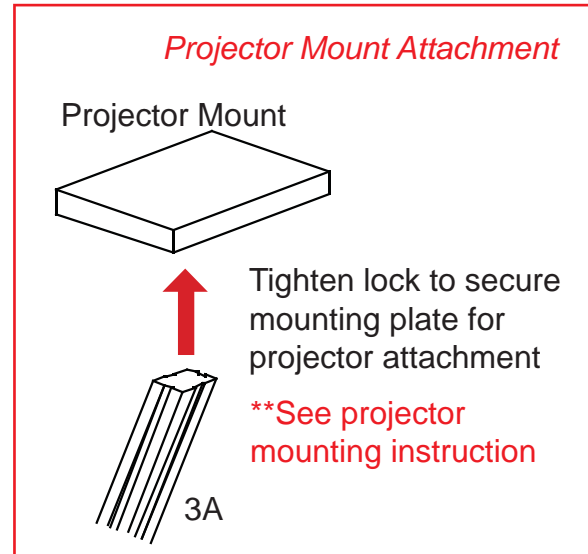

Step 1:
NOTE: Can be assembled either face down on floor then lifted upright or upright as shown in drawings.

- A) Connect vertical leg assemblies [1 and 2] together by connecting horizontal extrusions [4] between assemblies tightening BLACK knobs on backside of extrusion making sure Velcro faces toward BACK and placing it about one inch up from bottom and tightening.
- B) Connect vertical extrusions [3 and 3A] to leg assemblies [1 and 2] using vertical connection bar as shown.
- C) Connect upper horizontal extrusion [4] between verticals [3 and 3A] placing it about one inch down from top.

NOTE: Make sure the lock is flush with extrusion before tightening. If lock will not fully engage, gently rock lock and extrusion while turning knob until lock fully opens.

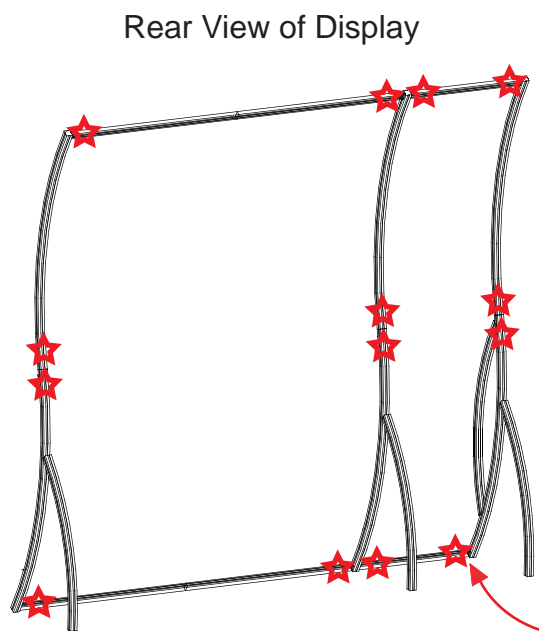

Rear View of Display

STAR indicates location of knobs on BACKSIDE of unit.

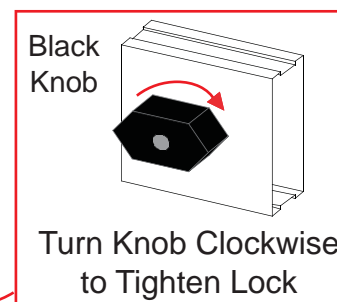

Step 1

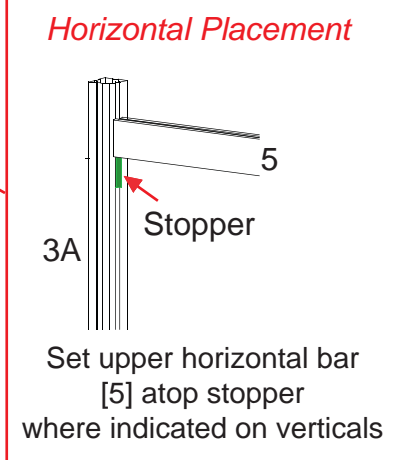
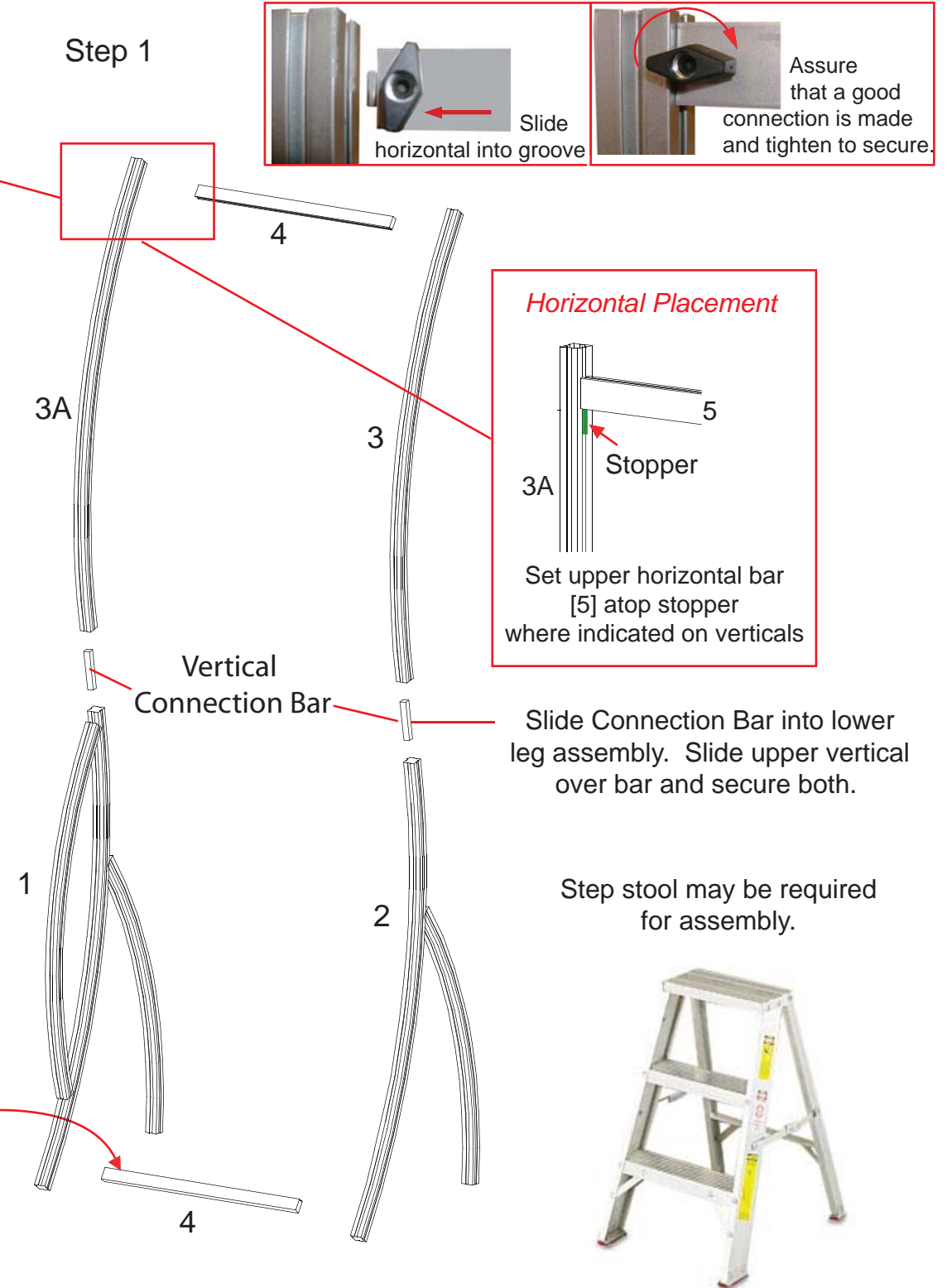

Slide Connection Bar into lower leg assembly. Slide upper vertical over bar and secure both.

Step stool may be required for assembly.



WHEN DISASSEMBLING TIGHTEN ALL BLACK KNOBS TO PREVENT LOSS DURING SHIPPING

Part Number	Description
5	Right Leg Assembly
6	Upper Curved Vertical
7	69" w Horizontal w/ Hinge Facing UP
8	69" w Horizontal w/ Hinge Facing DOWN

Step 2:

NOTE: Can be assembled either face down on floor then lifted upright or upright as shown in drawings.

- A) Connect vertical extrusion [6] to leg assembly [5] using vertical connection bar as shown.
- B) Connect horizontal extrusions [7 and 8] between vertical assemblies by tightening BLACK knobs on backside of extrusion making sure Velcro faces toward BACK.

NOTE: Make sure the lock is flush with extrusion before tightening. If lock will not fully engage, gently rock lock and extrusion while turning knob until lock fully opens.

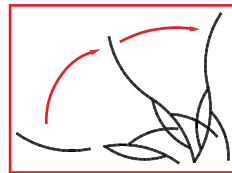

Step 2

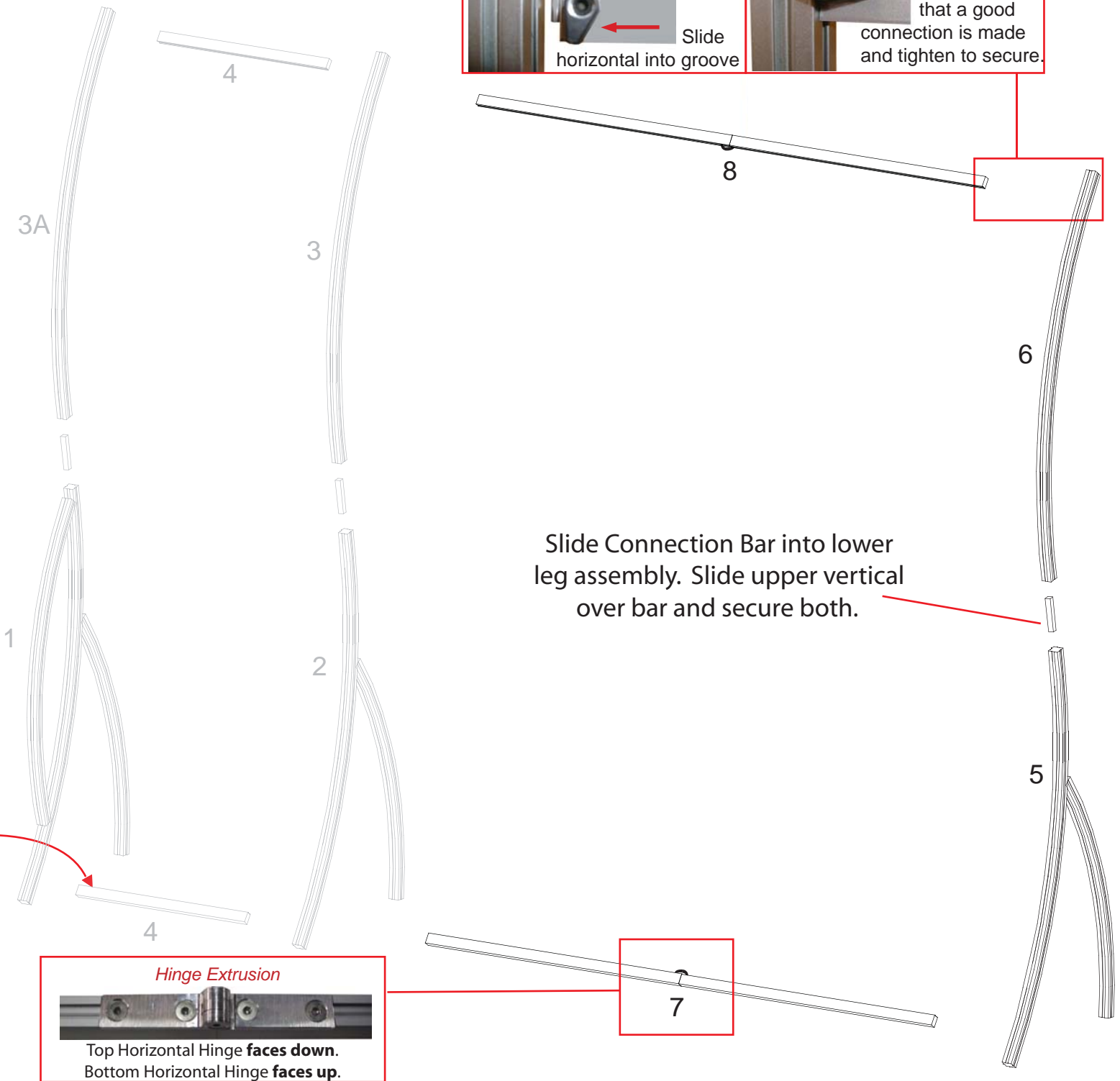

NOTE: When assembling horizontals they should be placed approximately one inch from TOP and BOTTOM.

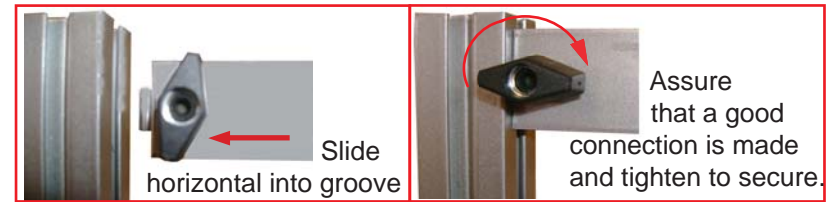

Slide horizontal into groove

Assure that a good connection is made and tighten to secure.

Rear View of Display

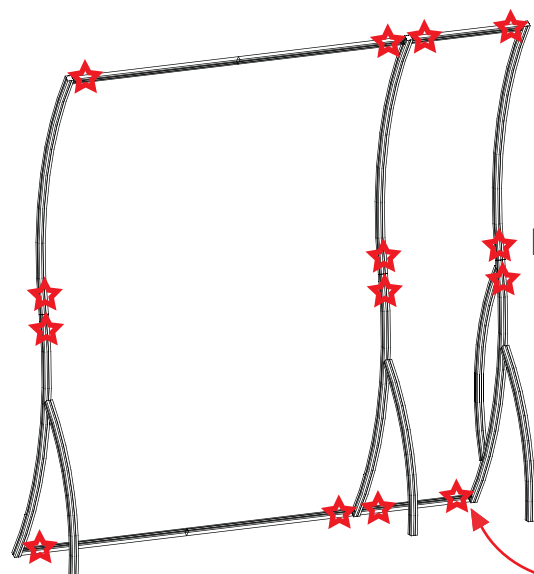

STAR indicates location of knobs on BACKSIDE of unit.

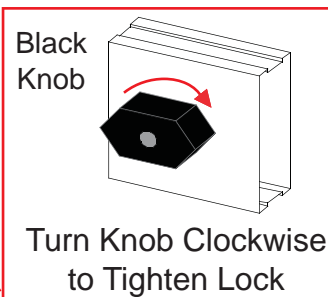

Black Knob

Turn Knob Clockwise to Tighten Lock



Hinge Extrusion

Top Horizontal Hinge faces down.
Bottom Horizontal Hinge faces up.

Slide Connection Bar into lower leg assembly. Slide upper vertical over bar and secure both.

WHEN DISASSEMBLING TIGHTEN ALL BLACK KNOBS TO PREVENT LOSS DURING SHIPPING

Part Number	Description
9	Middle Leg Assembly
10	Upper Curved Vertical
11	69" w Horizontal w/ Hinge Facing UP
12	69" w Horizontal w/ Hinge Facing DOWN

866.652.2100

NOTE: When assembling horizontals they should be placed approximately one inch from TOP and BOTTOM.

Step 1:

NOTE: Can be assembled either face down on floor then lifted upright or upright as shown in drawings.

- A) Connect vertical extrusion [10] to leg assembly [9] using vertical connection bar as shown.
- B) Connect horizontal extrusions [11 and 12] between vertical assemblies by tightening BLACK knobs on backside of extrusion making sure Velcro faces toward BACK.

NOTE: Make sure the lock is flush with extrusion before tightening. If lock will not fully engage, gently rock lock and extrusion while turning knob until lock fully opens.

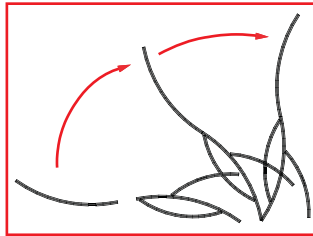

Step 3



Rear View of Display

Step stool may be required for assembly.

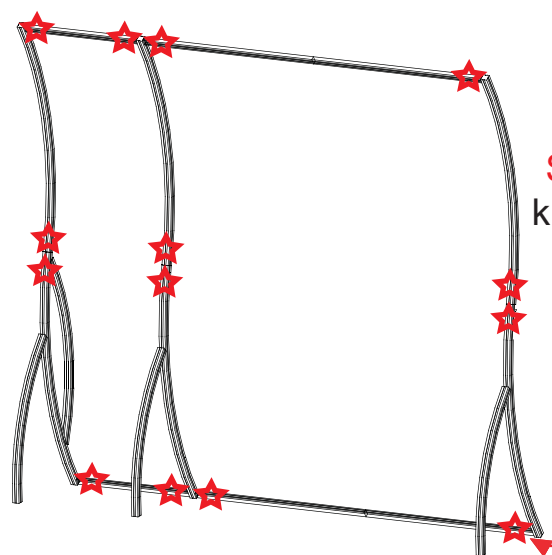

STAR indicates location of knobs on BACKSIDE of unit.

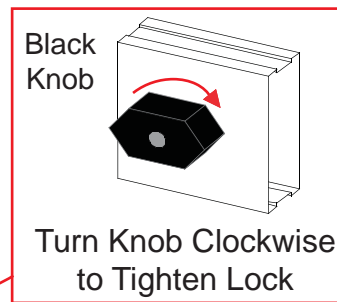

Slide Connection Bar into lower leg assembly. Slide upper vertical over bar and secure both.

Vertical Connection Bar

WHEN DISASSEMBLING TIGHTEN ALL BLACK KNOBS TO PREVENT LOSS DURING SHIPPING

866.652.2100

Part Number	Description
13	Right Leg Assembly w/ A10 Clamps Attached
14	Upper Curved Vertical w/ A10 Clamps Attached
15	23" w Horizontal

NOTE: When assembling horizontals they should be placed approximately one inch from TOP and BOTTOM.

Step 4

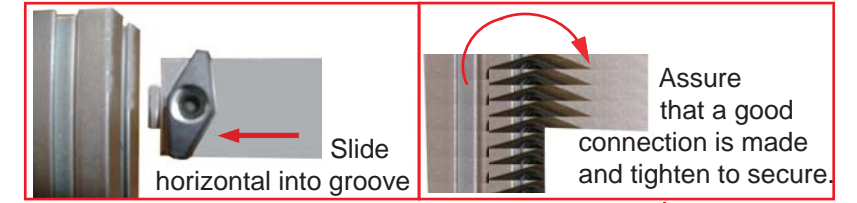

Step 2:

NOTE: Can be assembled either face down on floor then lifted upright or upright as shown in drawings.

- A) Connect vertical extrusion [14] to leg assembly [13] using vertical connection bar as shown.
- B) Connect horizontal extrusions [15] between vertical assemblies by tightening BLACK knobs on backside of extrusion making sure Velcro faces toward BACK.



NOTE: Make sure the lock is flush with extrusion before tightening. If lock will not fully engage, gently rock lock and extrusion while turning knob until lock fully opens.

Projector Mount Attachment

Projector Mount

Tighten lock to secure mounting plate for projector attachment

****See projector mounting instruction**

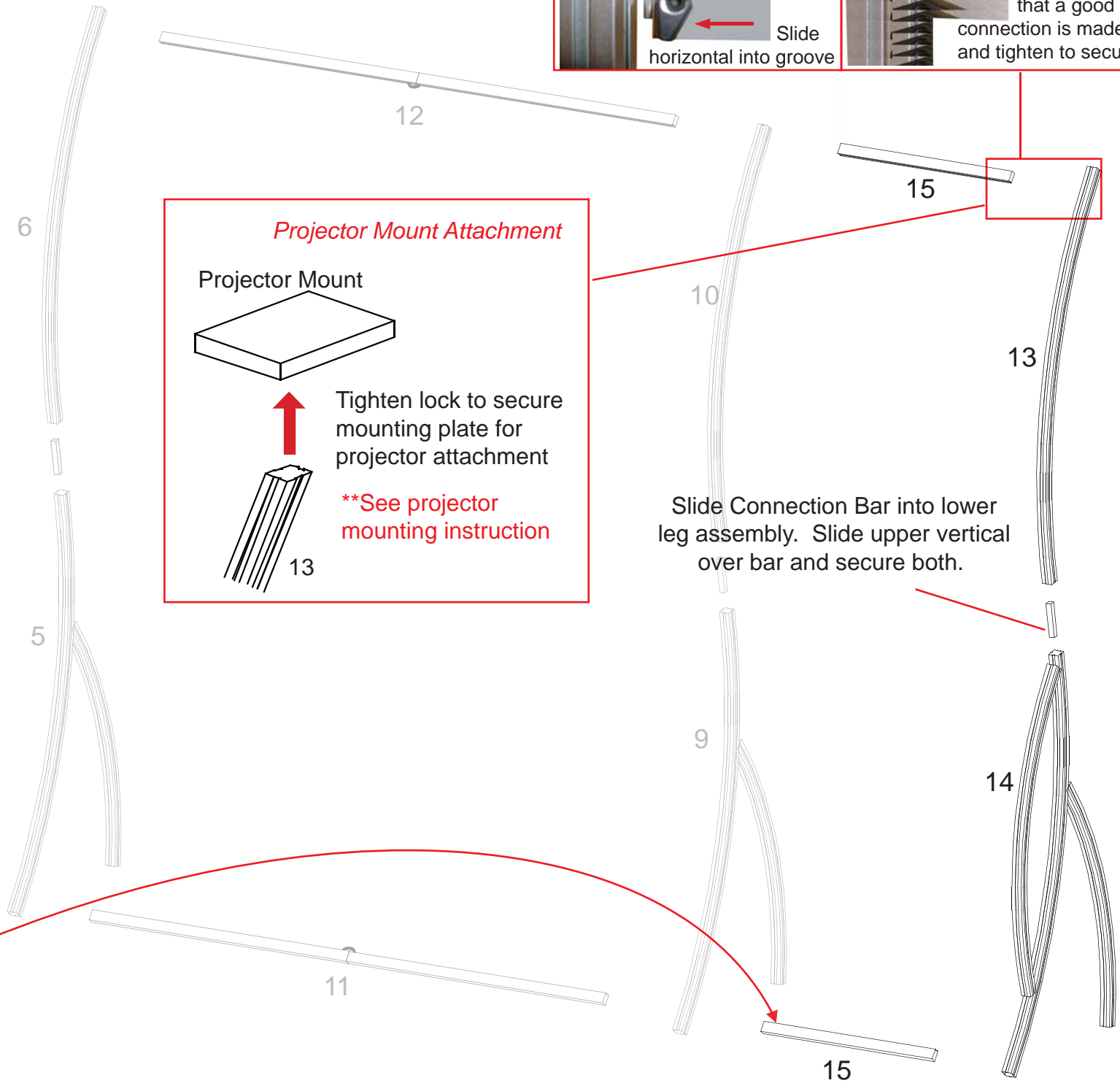

Rear View of Display

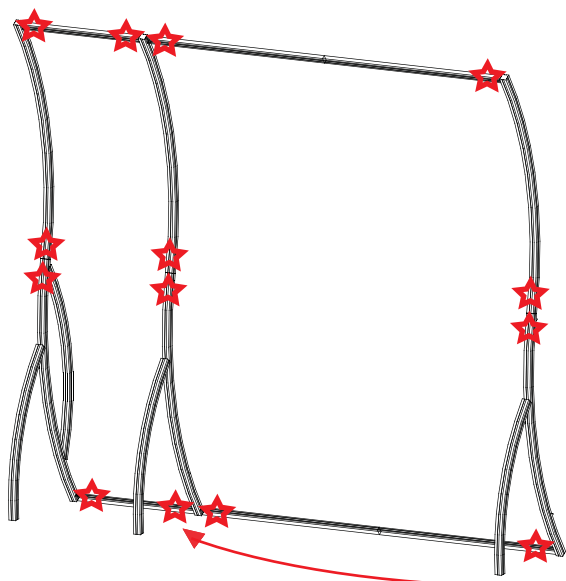

STAR indicates location of knobs on BACKSIDE of unit.

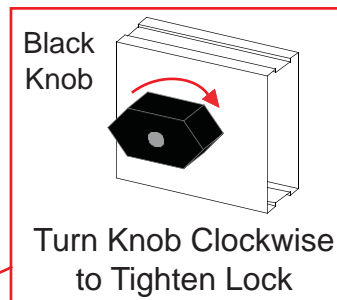

WHEN DISASSEMBLING TIGHTEN ALL BLACK KNOBS TO PREVENT LOSS DURING SHIPPING

Part Number	Qty	Description
17	1	Curve Horizontal Extrusion
18	1	Horizontal Extrusion
19	1	Horizontal Extrusion
20	1	Curve Horizontal Extrusion
21	1	Curve Horizontal Extrusion

Projector Screen Frame A

Part Number	Qty	Description
22	1	Lower Horizontal Extrusion
23	1	Side Extrusion
24	1	Upper Horizontal Extrusion
25	1	Side Extrusion
26	1	Lower Horizontal Extrusion

Projector Screen Frame B

Part Number	Qty	Description
27	1	Lower Horizontal Extrusion
28	1	Side Extrusion
29	1	Upper Horizontal Extrusion
30	1	Side Extrusion
31	1	Lower Horizontal Extrusion

- Steps:
- 1) Attach horizontal pieces together [18 to 17 and 19 to 20].
 - 2) Assemble screen frame pieces together.
 - 3) Connect 2 assembled frames together by attaching assembled horizontal pieces from step 1 to back of both frames.

866.652.2100

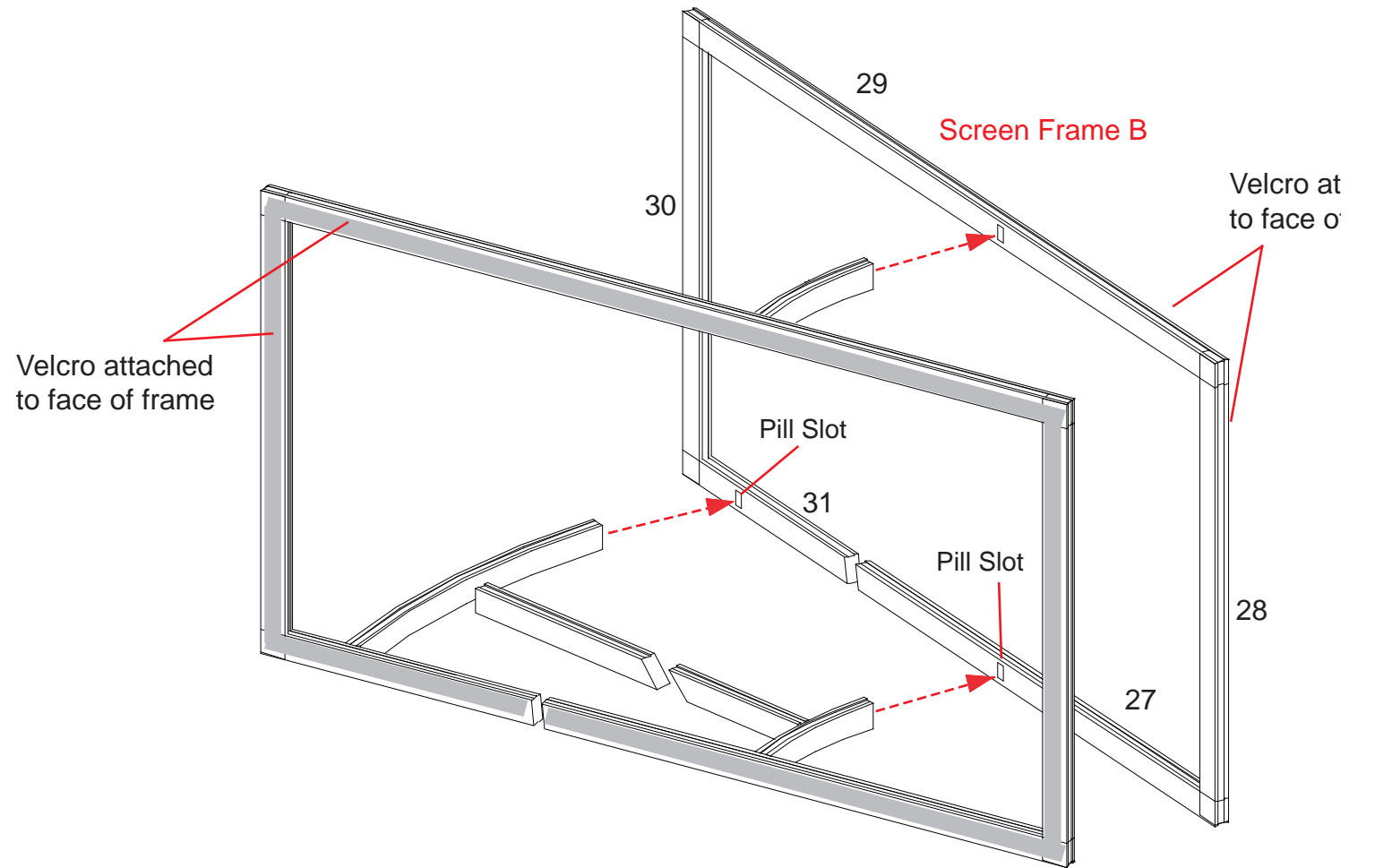
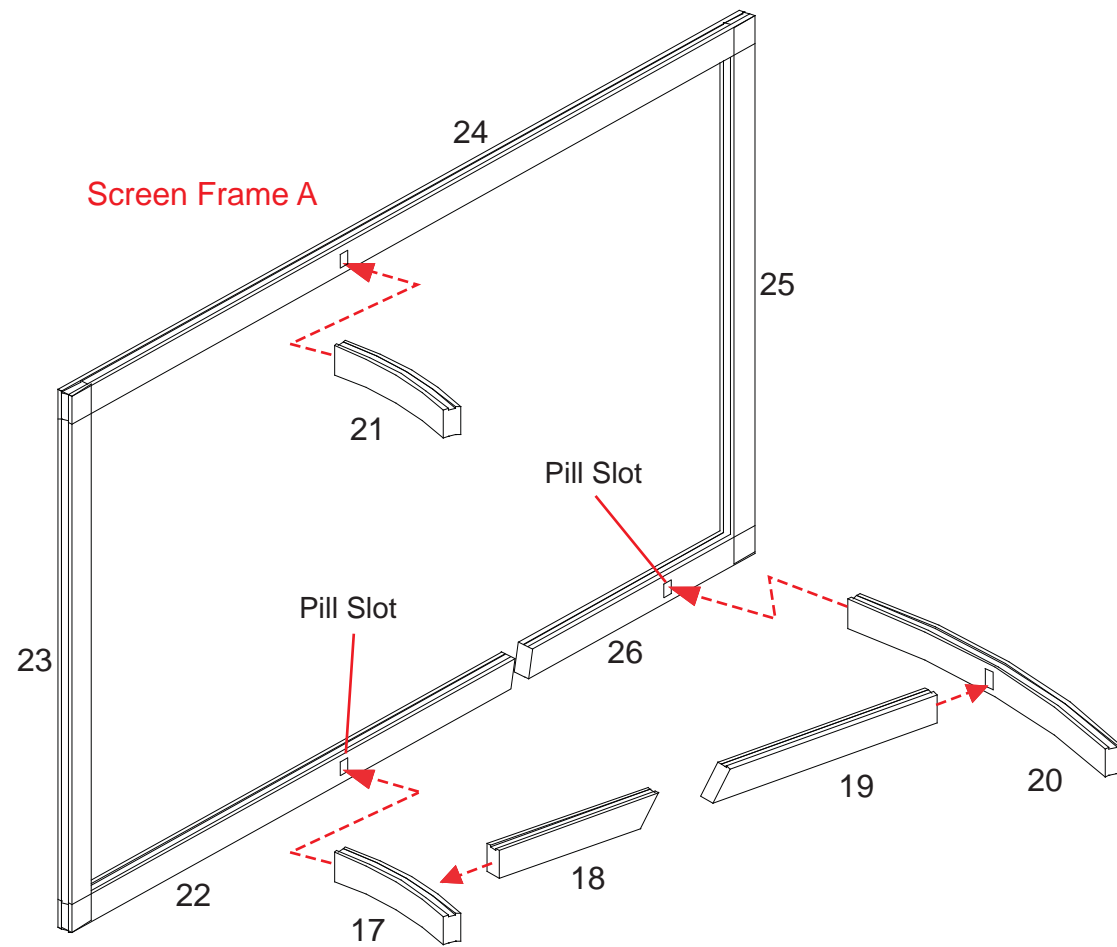
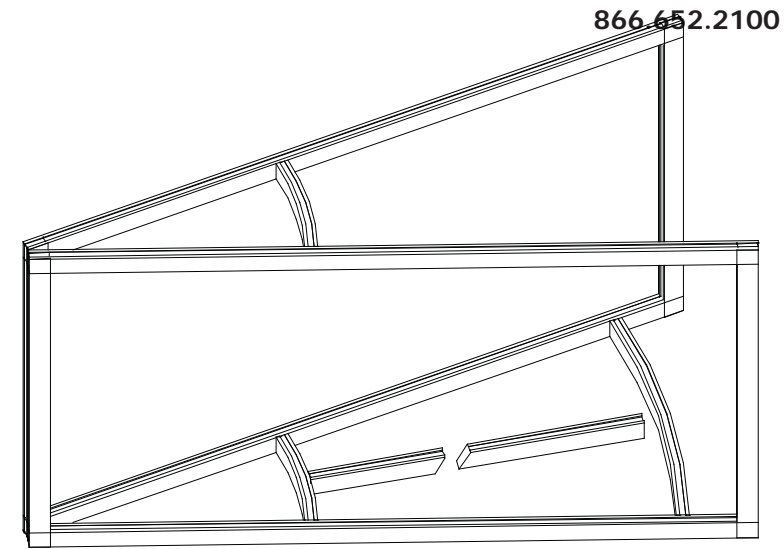

WHEN DISASSEMBLING TIGHTEN ALL BLACK KNOBS TO PREVENT LOSS DURING SHIPPING

866.652.2100

Decorative Blade Attachment
(if accidentally removed)
Slide A10 Clamp into groove of square extrusion.



When desired location is found, tighten set screw to secure.



Tighten black plastic set screw to secure Wing in place.



Attach decorative wing and blades to A10's attached to Backwall as shown.

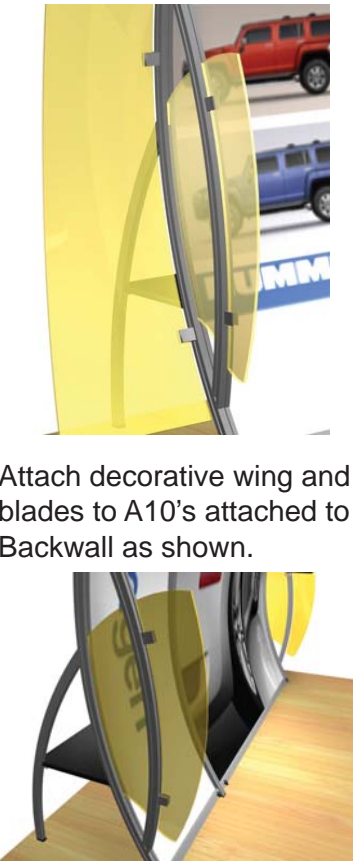

Hex Key Tool
(if necessary)



Flathead Screwdriver



Projector Screen Frame Attachment

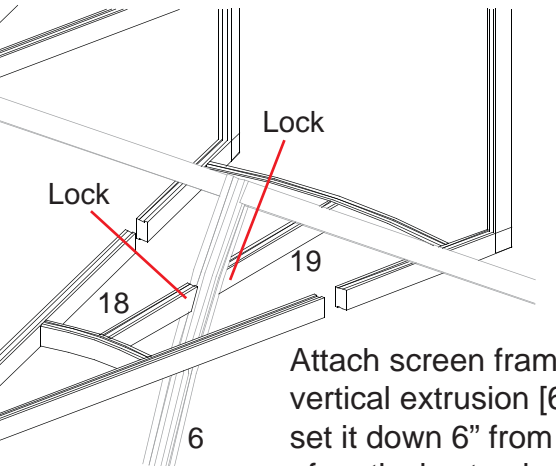

Attach screen frame to vertical extrusion [6] and set it down 6" from top of vertical extrusion.

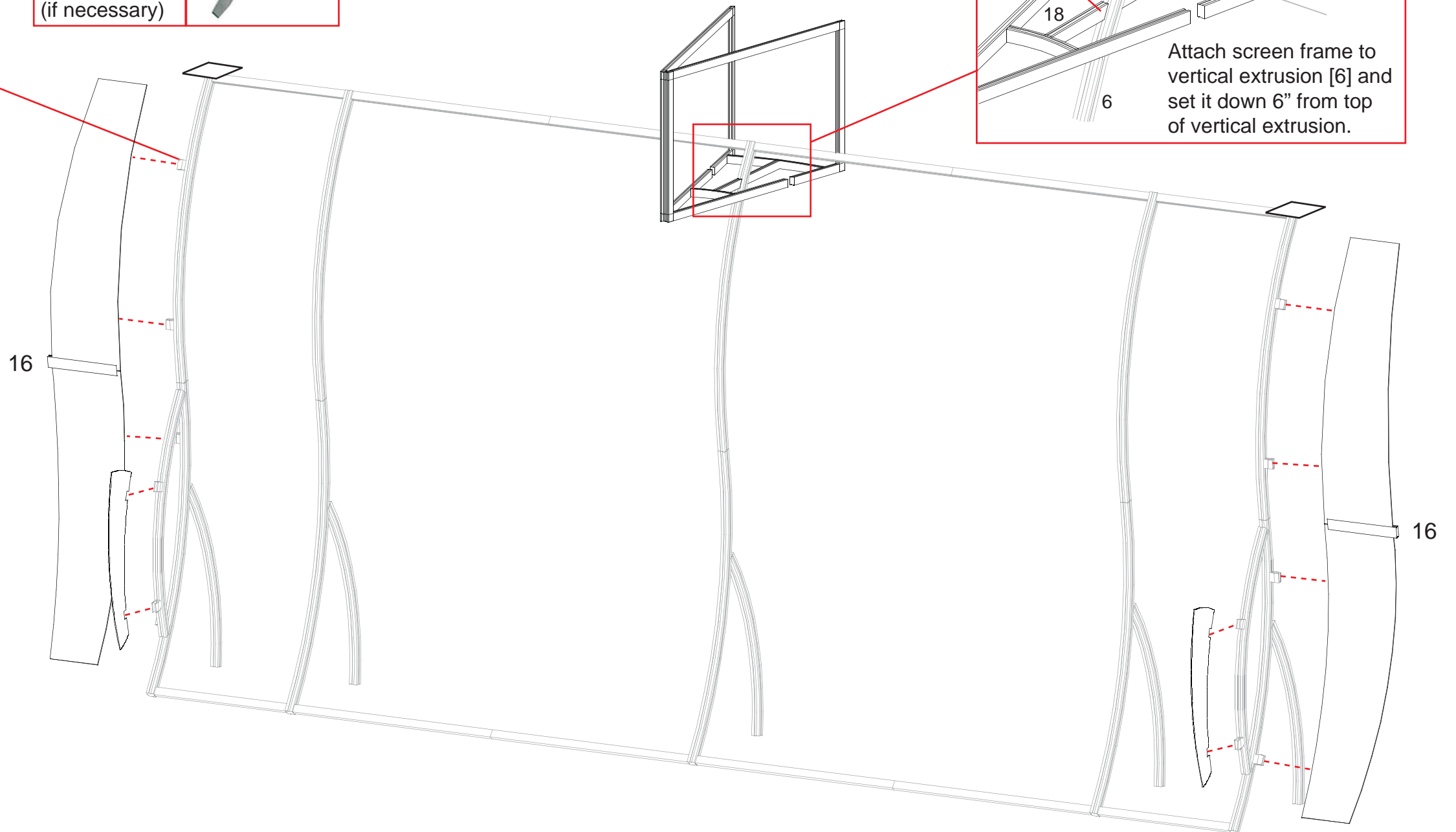

Literature Rack Attachment

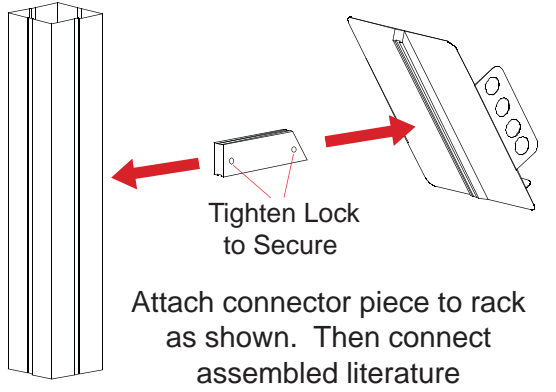

Tighten Lock to Secure

Attach connector piece to rack as shown. Then connect assembled literature rack to vertical extrusion.

WHEN DISASSEMBLING TIGHTEN ALL BLACK KNOBS TO PREVENT LOSS DURING SHIPPING

866.652.2100

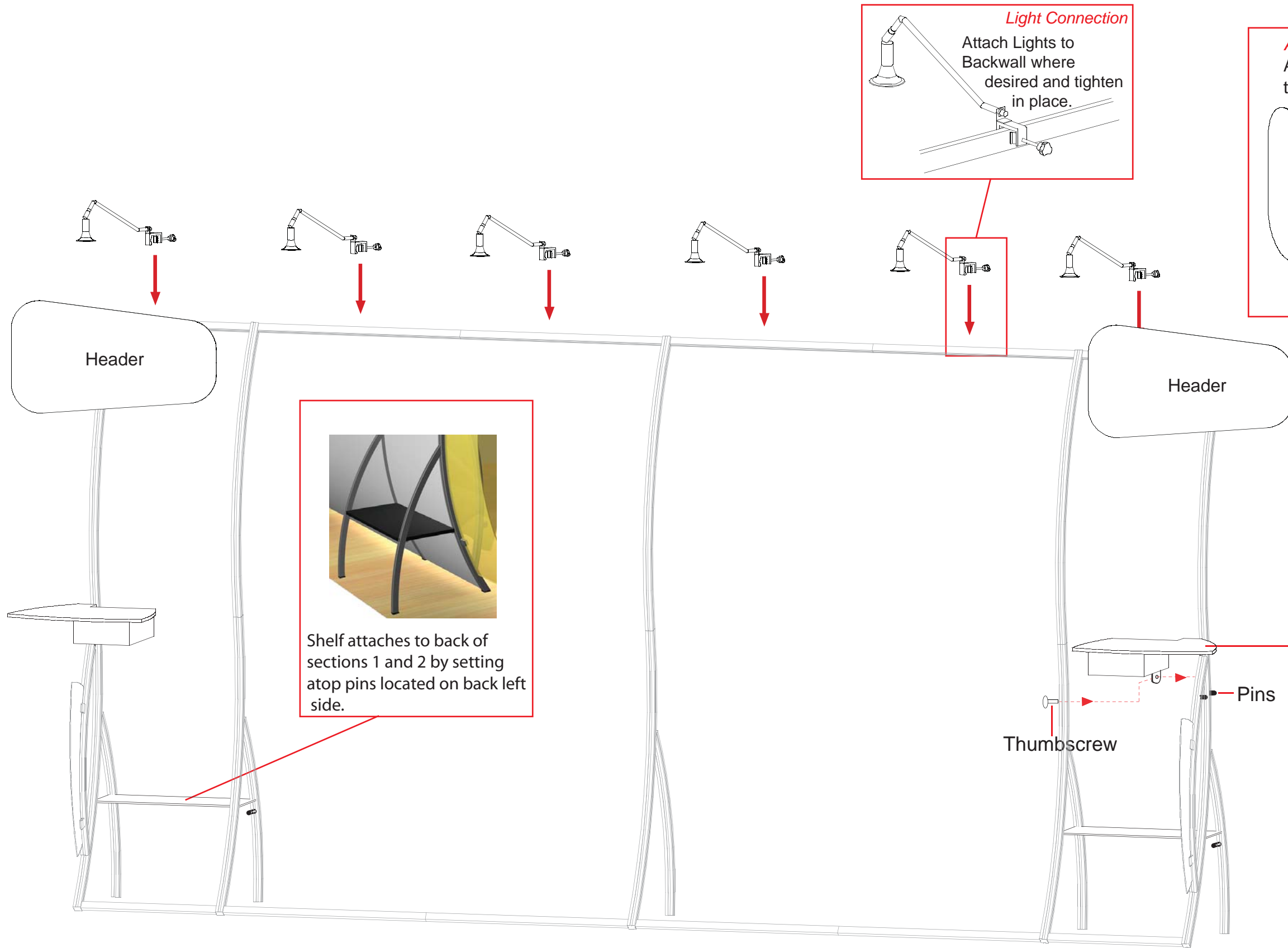

Light Connection
 Attach Lights to Backwall where desired and tighten in place.

Accessory Attachment
 Attach Header support to Backwall then attach header to support by Velcroing it.

Shelf attaches to back of sections 1 and 2 by setting atop pins located on back left side.

Cubby Attachment
 Shelf attaches to section 5 by setting atop pins located on right side and securing into place with thumbscrew on left.

Slide onto back pin first.
 When attaching counter you will need to first slide shelf onto back pin then set down on front pin.

WHEN DISASSEMBLING TIGHTEN ALL BLACK KNOBS TO PREVENT LOSS DURING SHIPPING

Part Number	Description
A	Left Leg Assembly
B	Right Leg Assembly
C	Horizontal Extrusion
D	Horizontal Extrusion w/ Door Stopper

Step 1:

- A) Connect lower horizontal extrusion [C] between bottom of leg assemblies [A and B] as shown.
- B) Insert Laminated infill into grooves of leg assemblies [A and B].
- C) Attach extrusion door between leg assemblies [A and B] and atop laminated infill.
- D) Attach upper horizontal extrusion w/ door stopper [D] between leg assemblies [A and B], and set flush with top of legs [A and B].

NOTE: Make sure the lock is flush with extrusion before tightening. If lock will not fully engage, gently rock lock and extrusion while turning knob until lock fully opens.

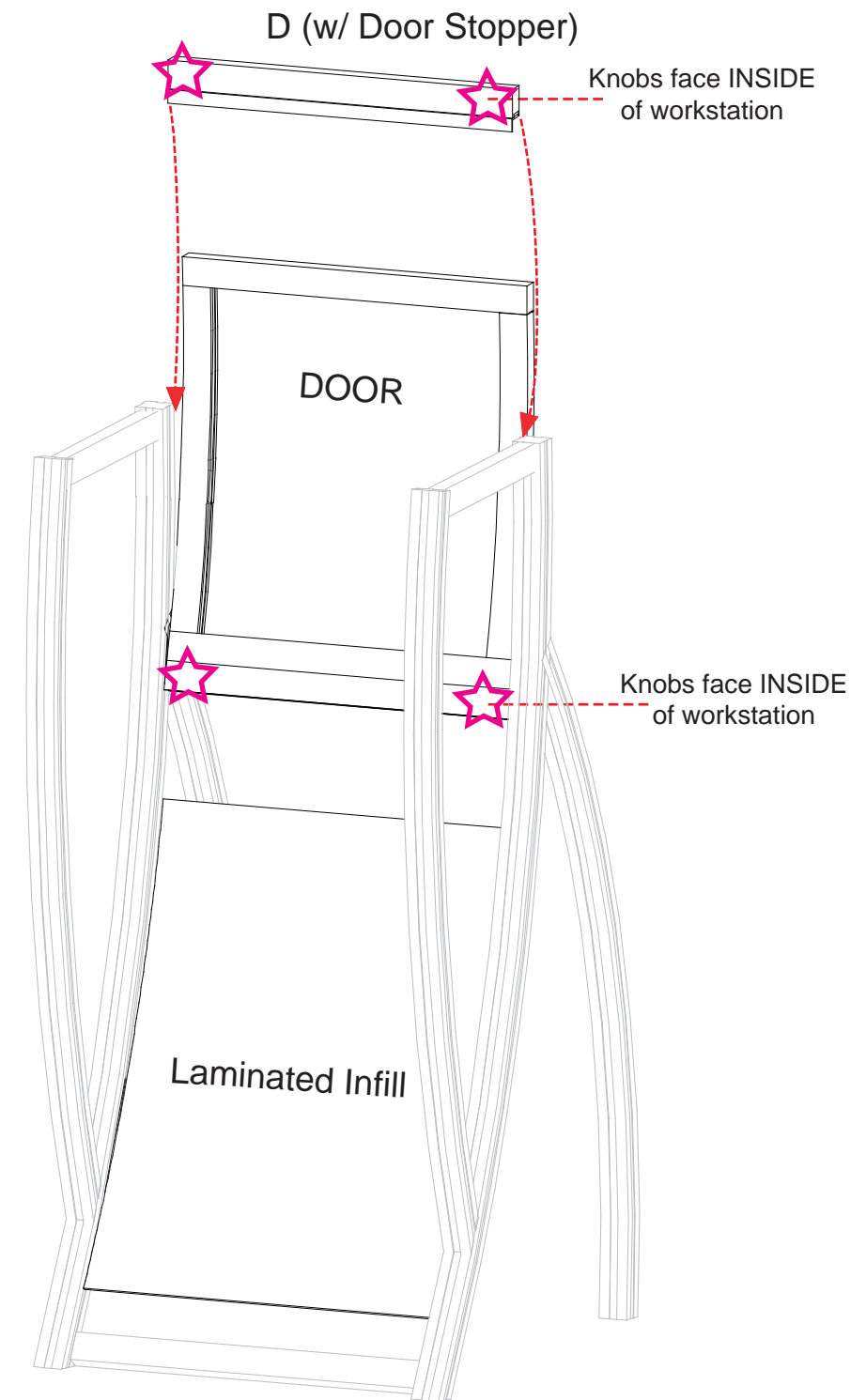
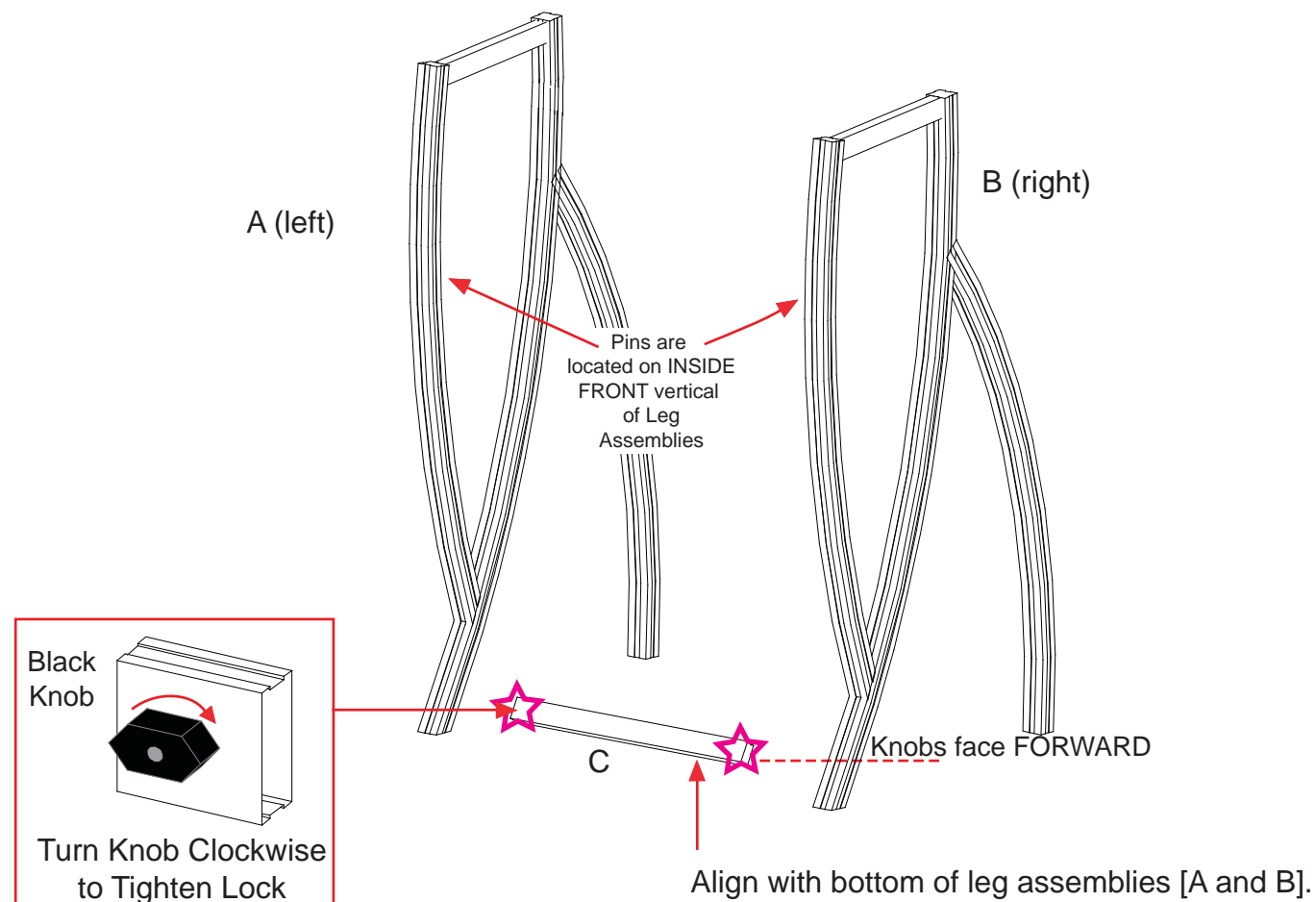

WHEN DISASSEMBLING TIGHTEN ALL BLACK KNOBS TO PREVENT LOSS DURING SHIPPING

Part Number	Description
E	Horizontal Extrusion
F	Horizontal Extrusion

Step 2:

- A) Attach horizontal extrusion [E] between vertical leg assemblies [A and B] as shown below.
- B) Insert Laminated infill into grooves of vertical leg assemblies [A and B].
- C) Attach upper horizontal extrusion [F] between vertical leg assemblies [A and B] atop infill.
- D) Place internal shelf into assembled pedestal atop pins..
- E) Set Counter atop assembled pedestal and secure with Velcro straps attached to underside of top.

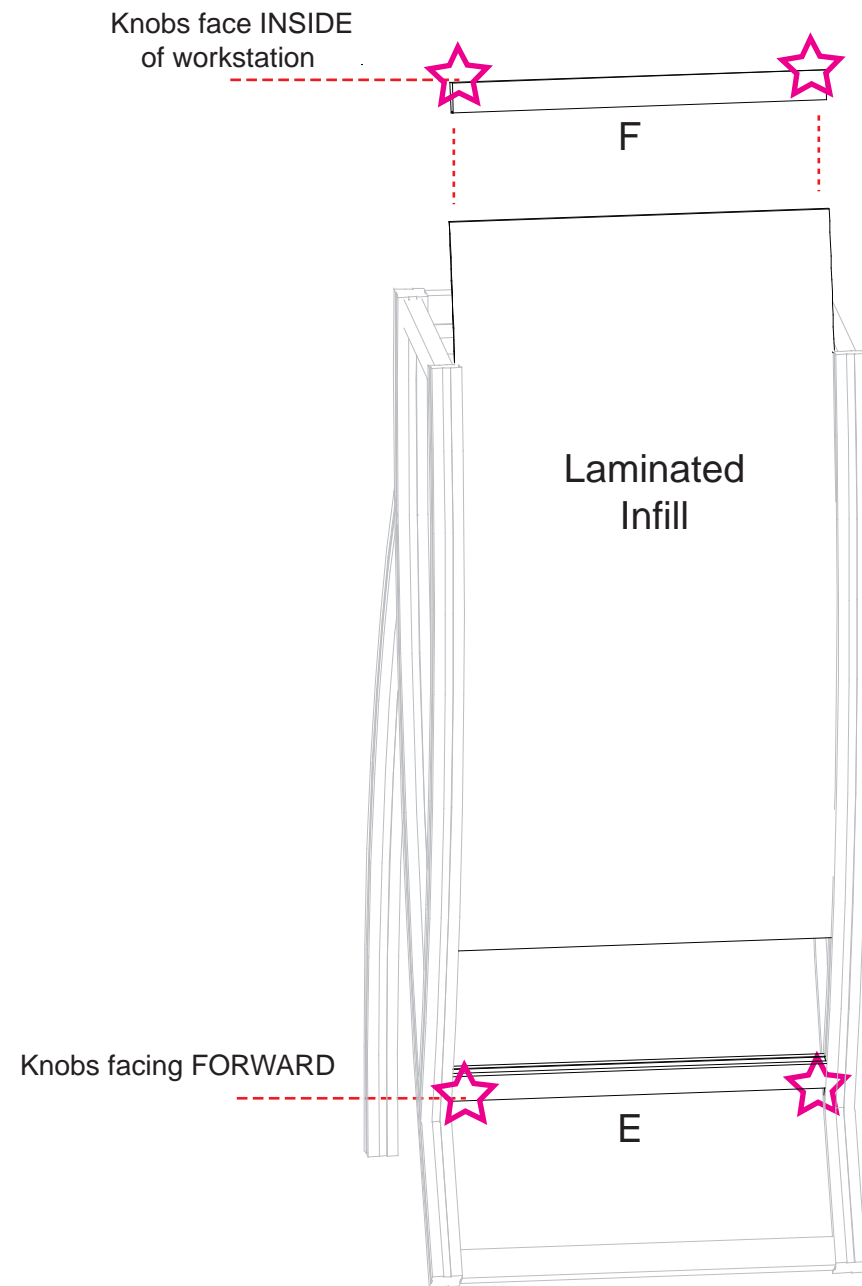

Place internal shelf into workstation then place counter atop assembled workstation.

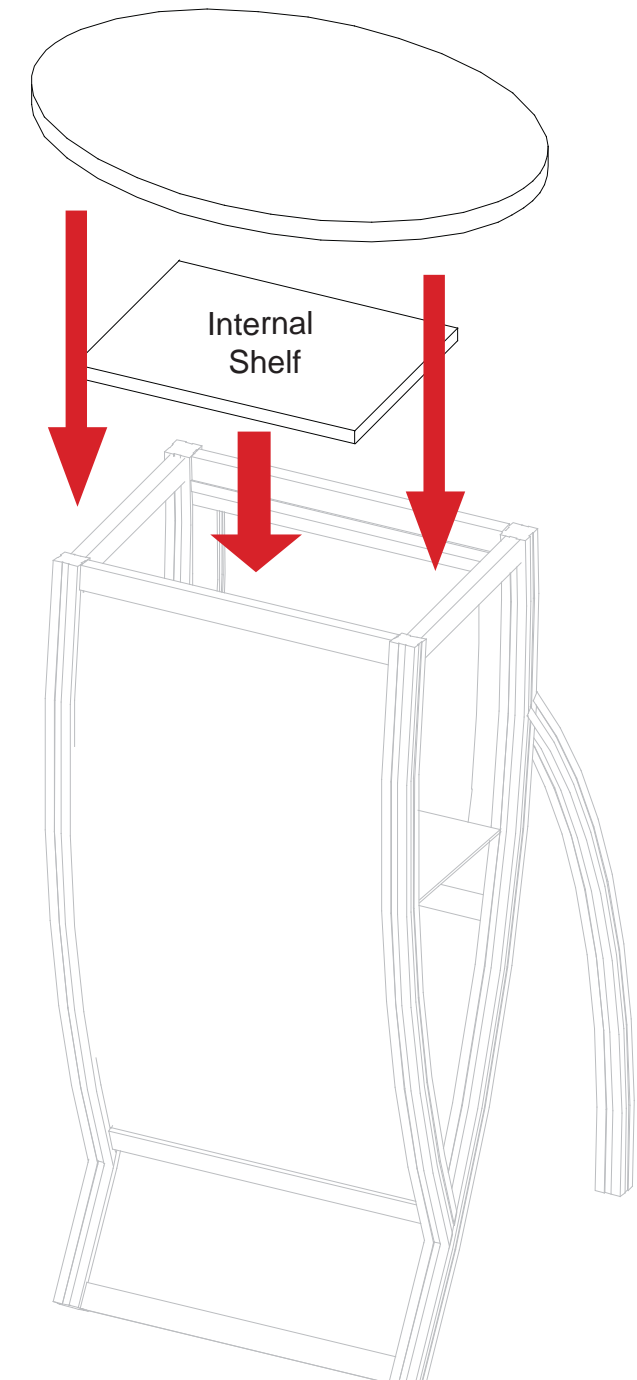

WHEN DISASSEMBLING TIGHTEN ALL BLACK KNOBS TO PREVENT LOSS DURING SHIPPING

Part Number	Qty	Description
32	1	Curved Vertical Extrusion
33	1	Curved Vertical Extrusion with Door Hinges
34	1	Curved Vertical Extrusion with Door Stop
35	1	Curved Vertical Extrusion
36/36a	1/1	16.5w Curve Horizontal Extrusion
37	2	17"w Horizontal Extrusion
38/38a	1/1	32.3"w Curve Horizontal Extrusion
39	2	17"w Horizontal Extrusion

866.652.2100

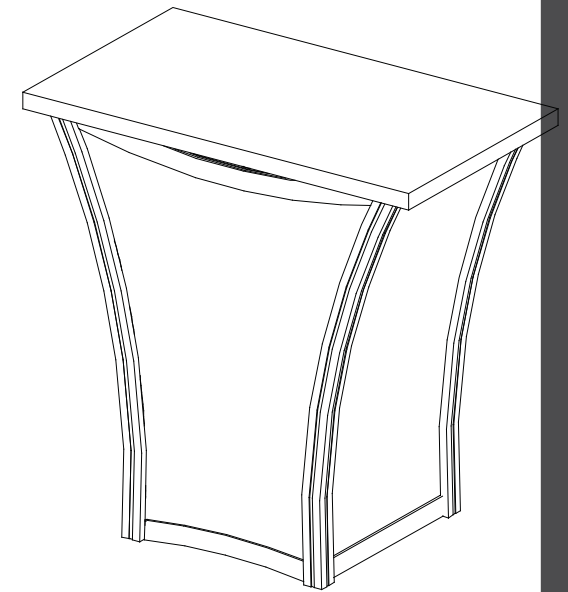

Steps

- 1) Attach lower horizontal extrusions [36, 36a and 37] between vertical extrusions [32, 33, 34 and 35].
- 2) Place inserts where indicated.
- 3) Attach upper horizontal extrusions [38, 38a and 39] between vertical extrusions [32, 33, 34 and 35] and atop inserts and door.
- 4) Attach pins to curved verticals where indicated.
- 5) Set internal shelf atop pins.
- 6) Set counter top on assembled base.

Graphic Attachment

Attach fabric graphic to back of upper and lower horizontal bars [36a and 38a]

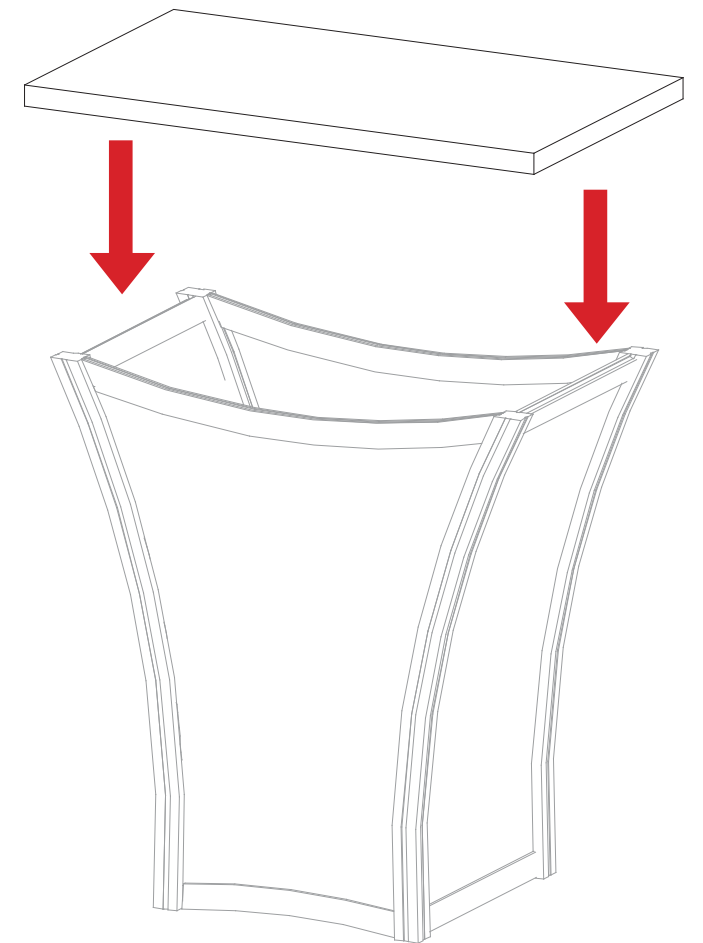
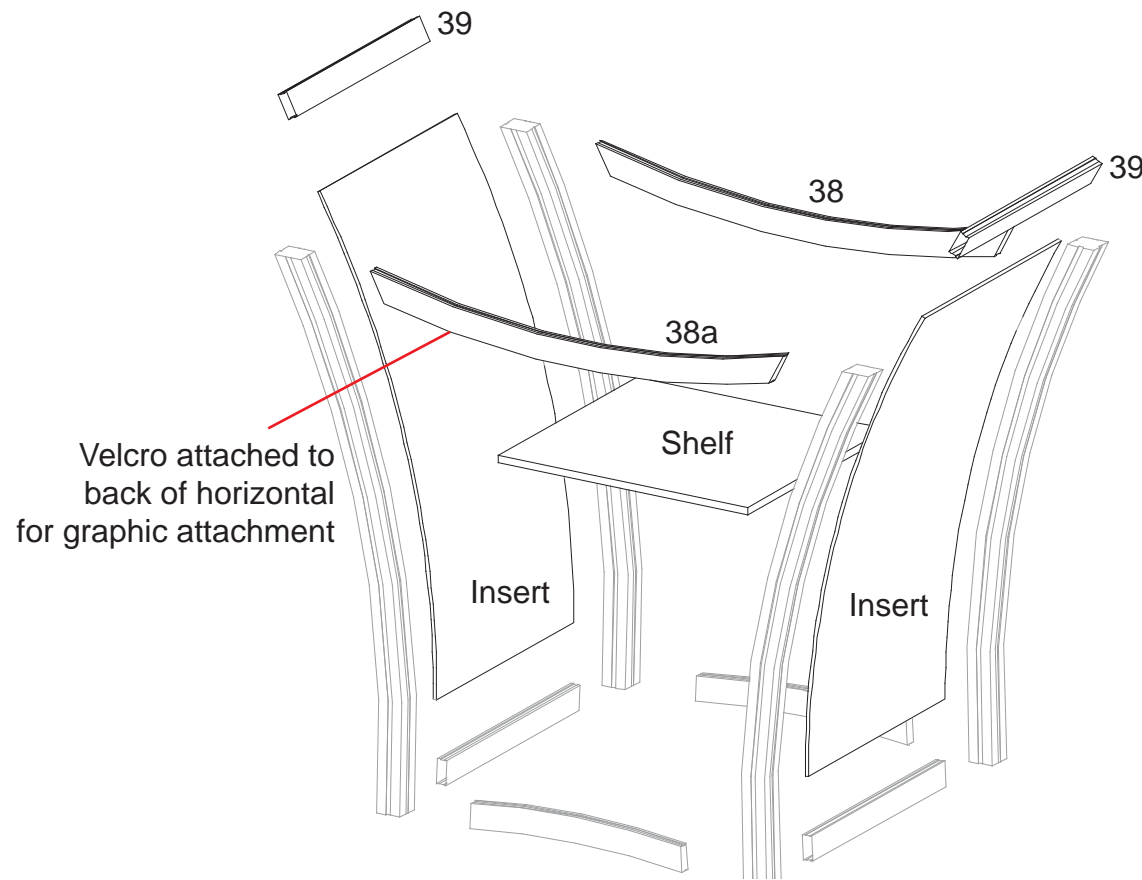
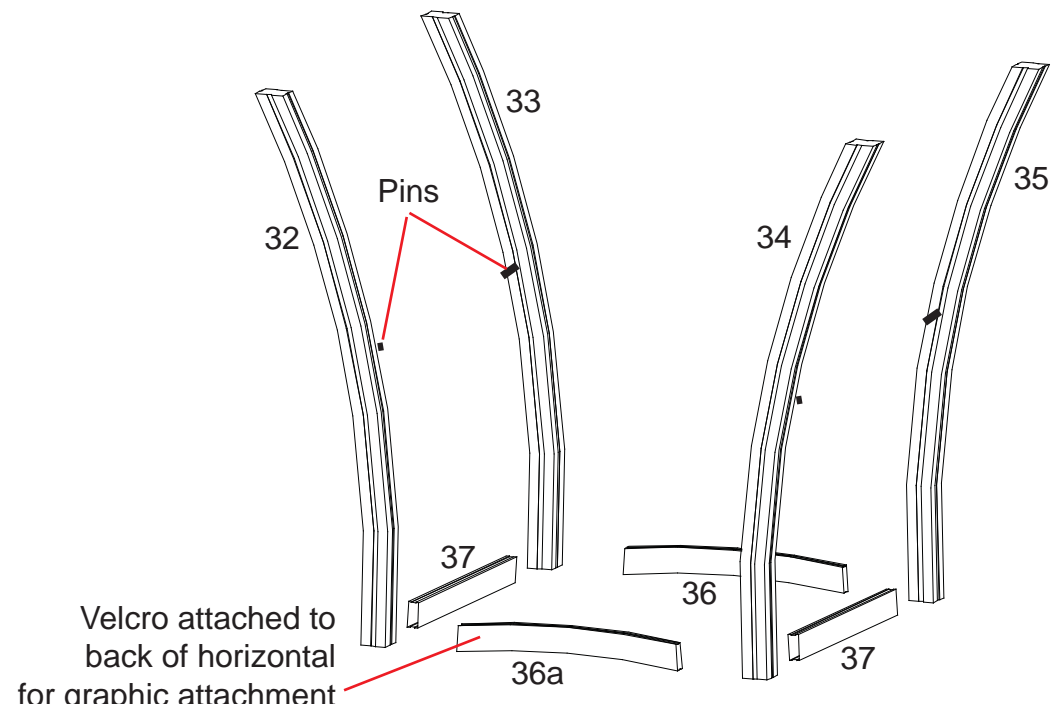

WHEN DISASSEMBLING TIGHTEN ALL BLACK KNOBS TO PREVENT LOSS DURING SHIPPING

Case #1 - Backwall Components

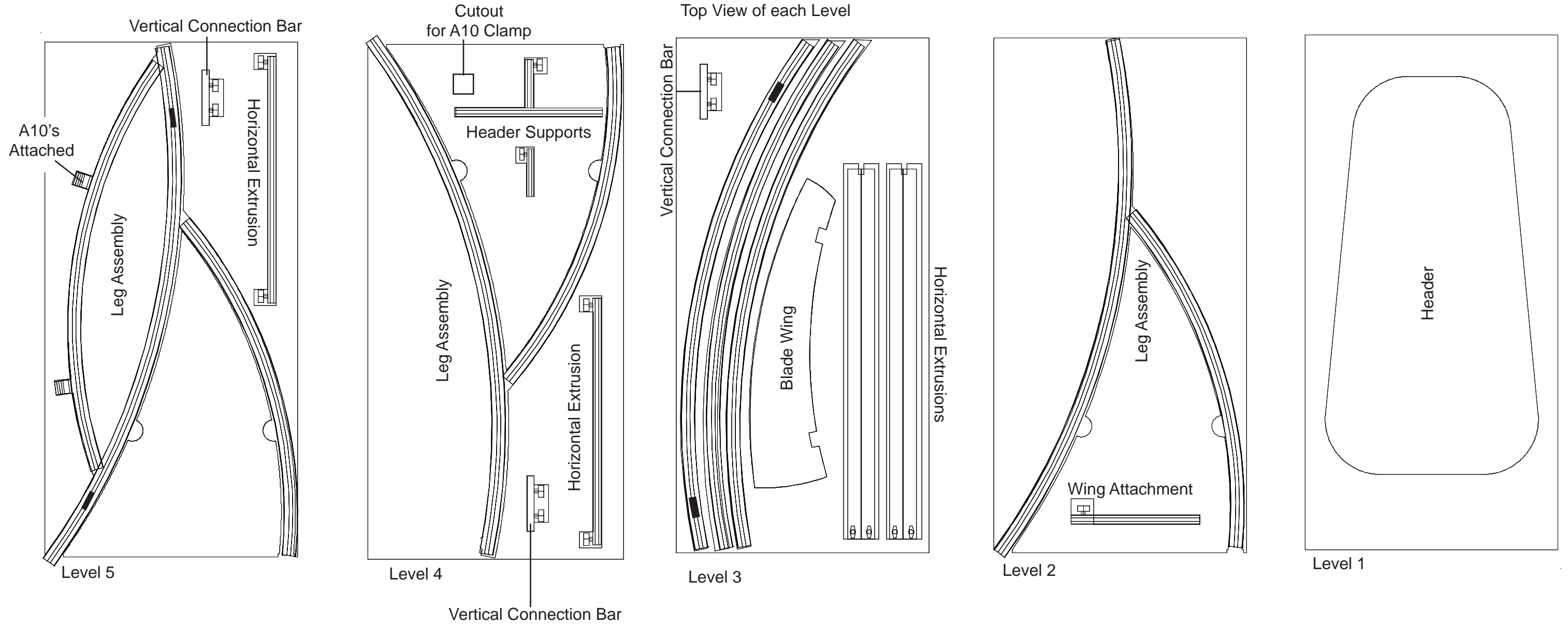

WHEN DISASSEMBLING TIGHTEN ALL BLACK KNOBS TO PREVENT LOSS DURING SHIPPING

Case # 2 - Backwall Components

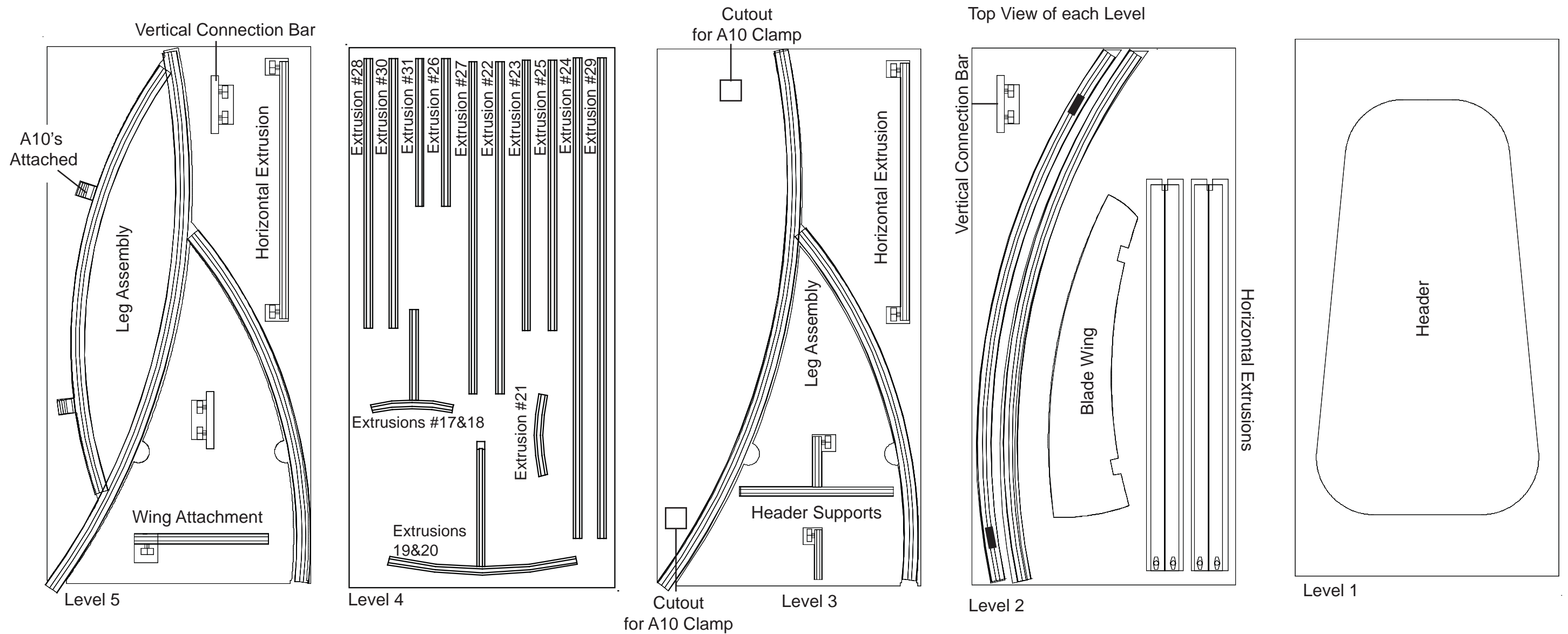

WHEN DISASSEMBLING TIGHTEN ALL BLACK KNOBS TO PREVENT LOSS DURING SHIPPING

Case #3 - Backwall Components

Top View of each Level

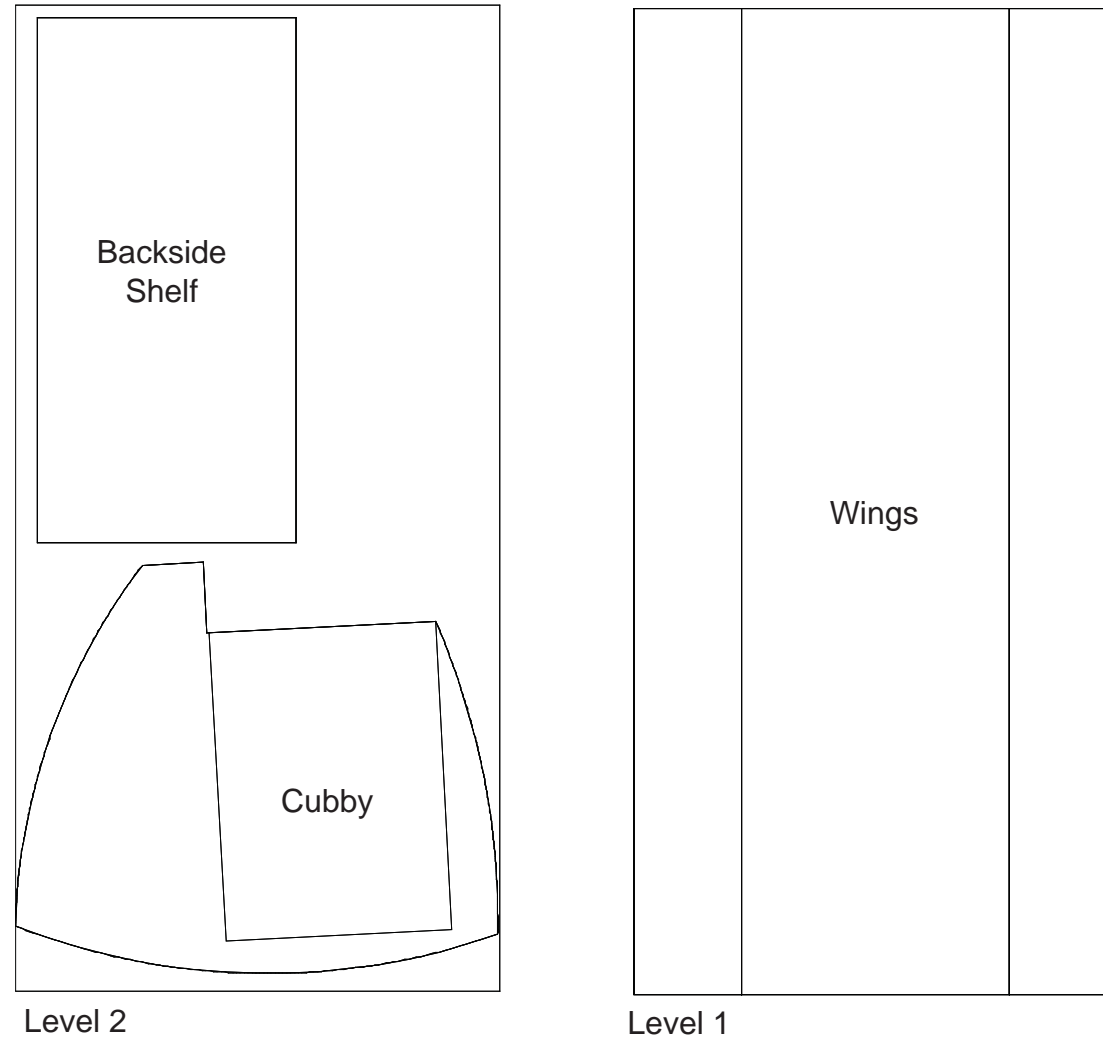

Additional Items:
- Graphics
- Setup Hardware

WHEN DISASSEMBLING TIGHTEN ALL BLACK KNOBS TO PREVENT LOSS DURING SHIPPING

Case # 4 - Backwall Components

Top View of each Level

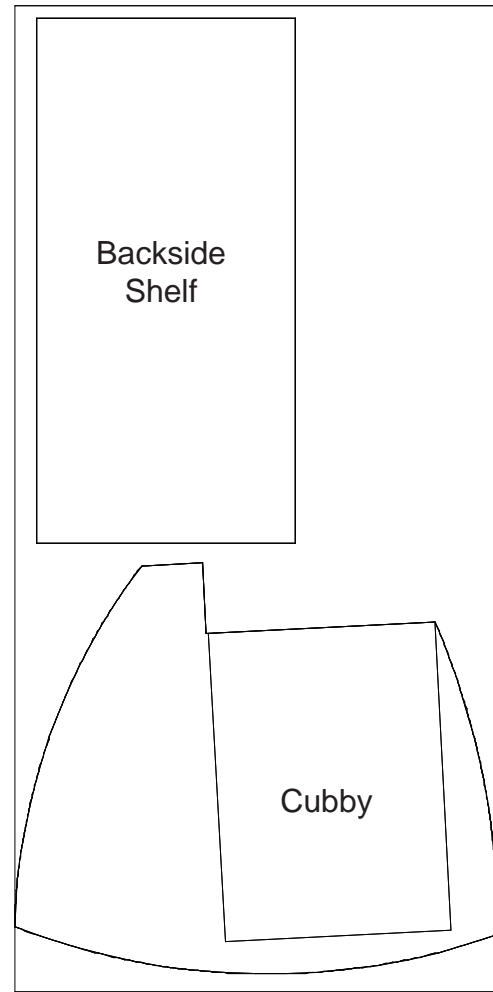

Level 2

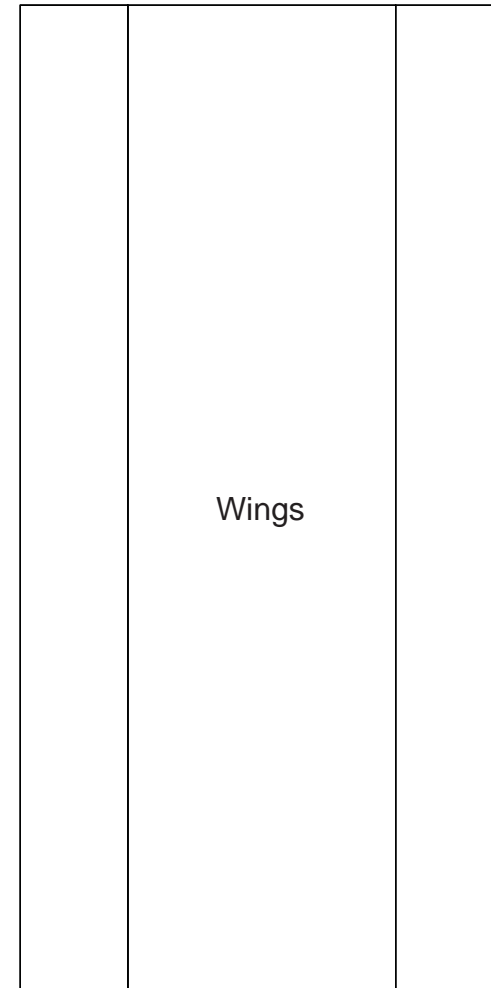

Level 1

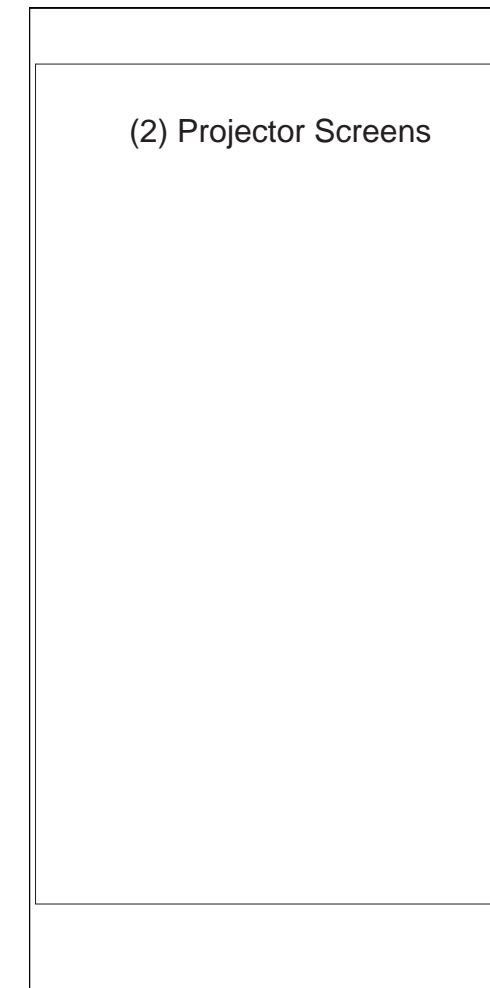

- Additional Items:*
- Graphics
 - (2) Literature Shelves

WHEN DISASSEMBLING TIGHTEN ALL BLACK KNOBS TO PREVENT LOSS DURING SHIPPING

Case # 5 -Workstation Components

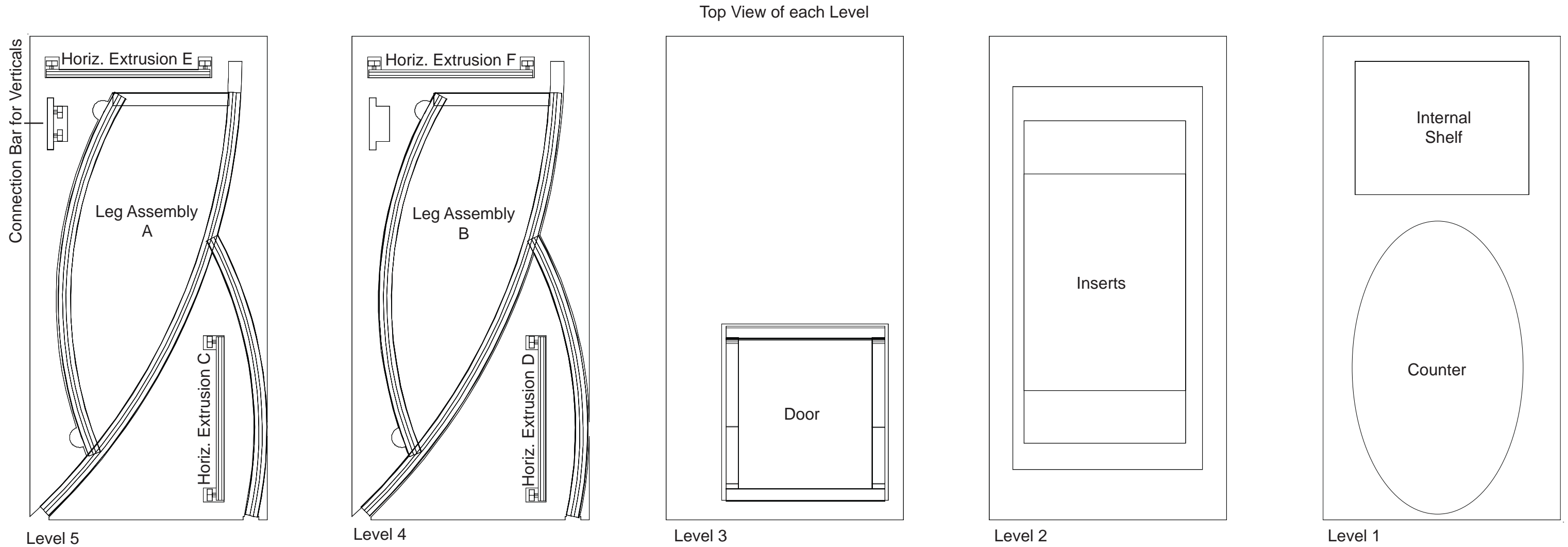

WHEN DISASSEMBLING TIGHTEN ALL BLACK KNOBS TO PREVENT LOSS DURING SHIPPING

Case # 6 - Workstation Components

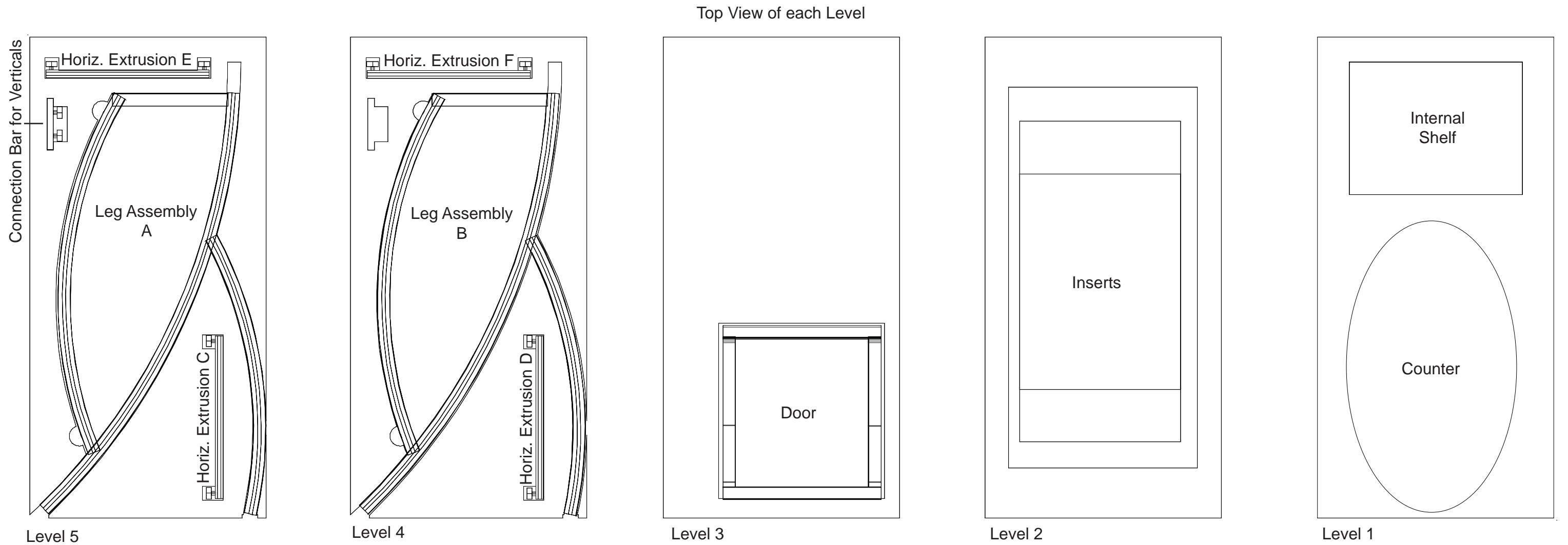

WHEN DISASSEMBLING TIGHTEN ALL BLACK KNOBS TO PREVENT LOSS DURING SHIPPING

Case #7 - Pedestal Components

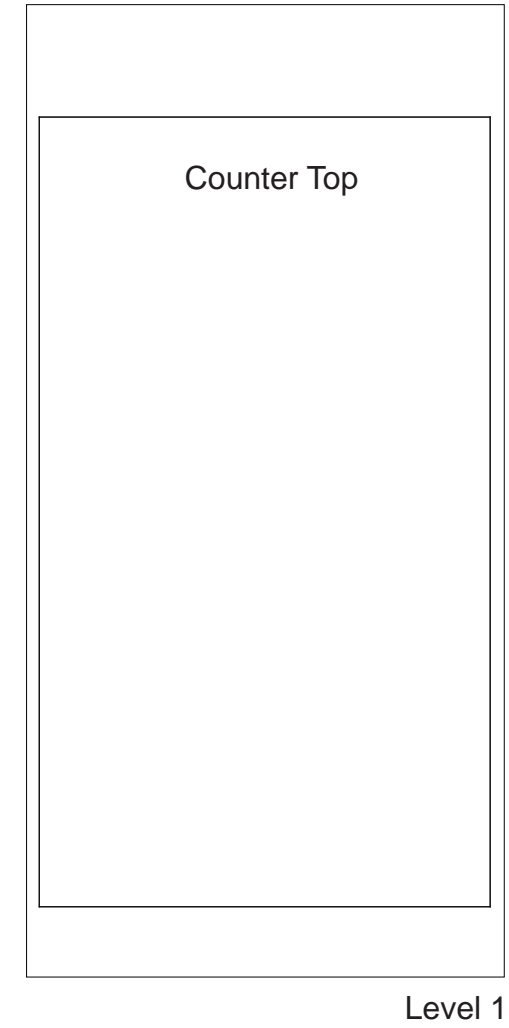
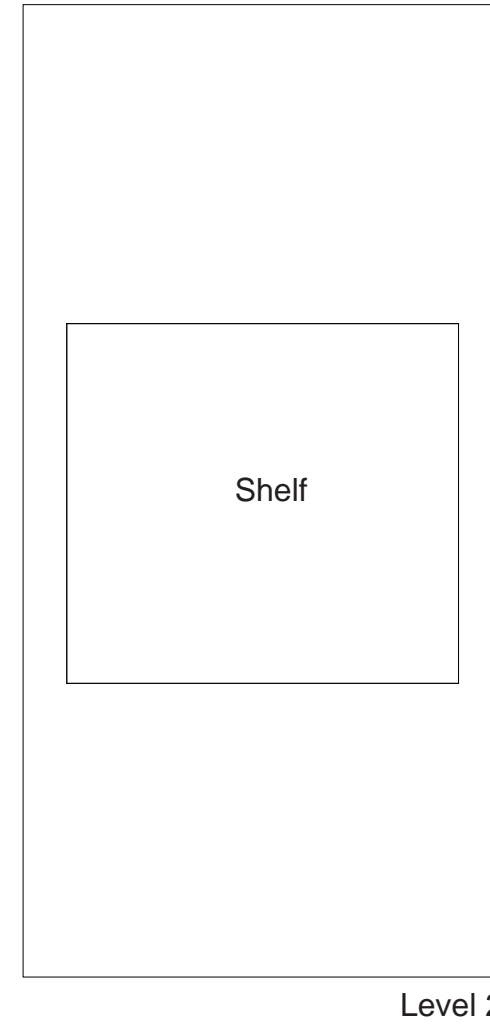
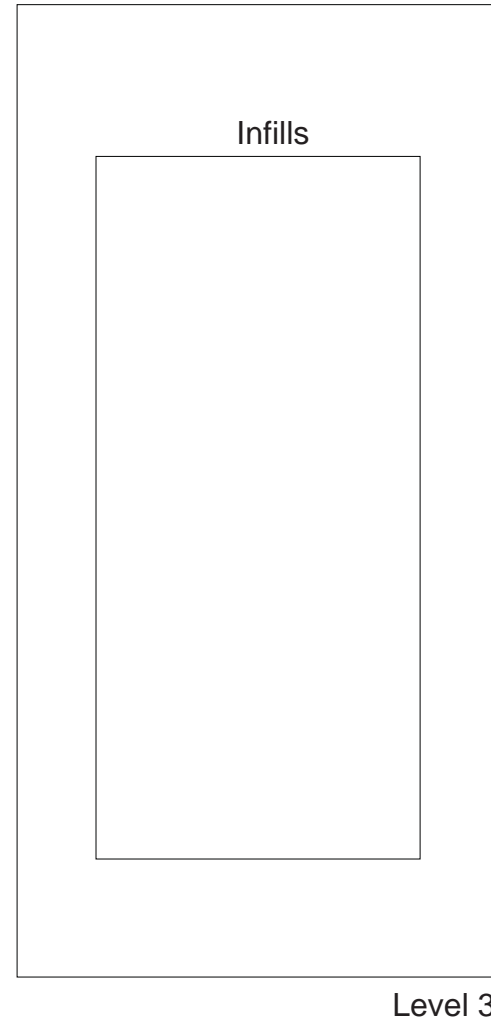
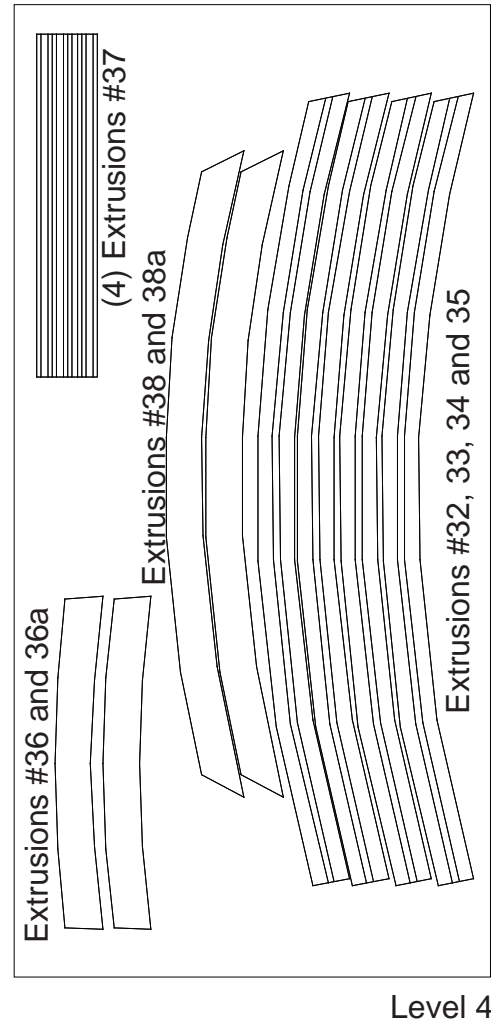

WHEN DISASSEMBLING TIGHTEN ALL BLACK KNOBS TO PREVENT LOSS DURING SHIPPING