

# Perfect 10 Hybrid Displays

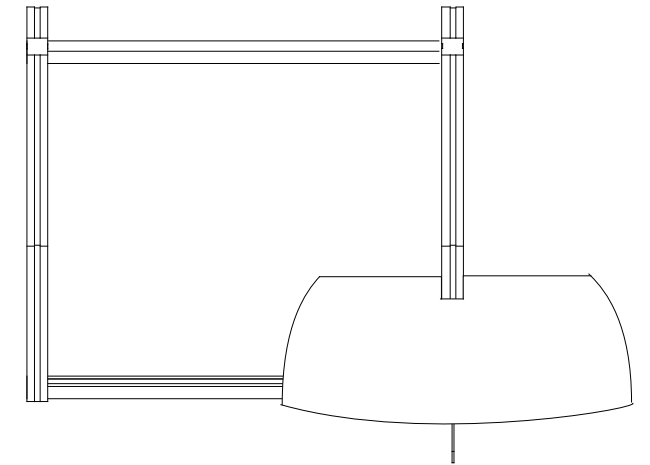
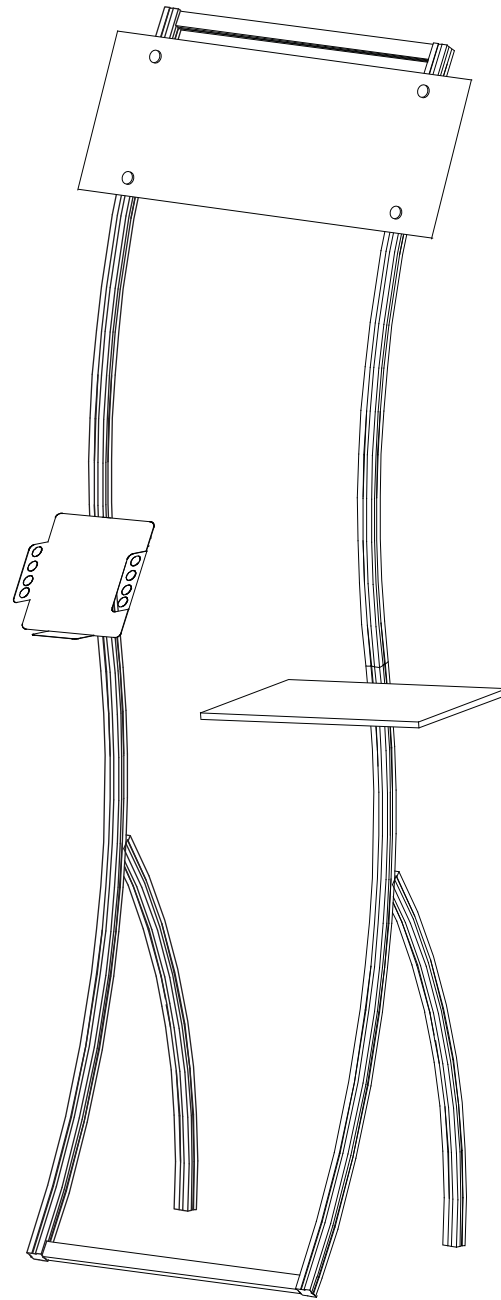

WHEN DISASSEMBLING ALUMINUM EXTRUSION, TIGHTEN ALL SETSCREWS AND LOCKS TO PREVENT LOSS DURING SHIPPING

Part Number	Description
10	Left Leg Assembly
11	Right Leg Assembly
12A	Upper Curved Vertical
12	Upper Curved Vertical
13	23" w Horizontal

**Step 1:**

NOTE: Can be assembled either face down on floor then lifted upright or upright as shown in drawings.



- A) Connect vertical leg assemblies [10 and 11] together by connecting horizontal extrusion [13] between assemblies tightening BLACK knobs on backside of extrusion making sure Velcro faces toward BACK and placing it about one inch up from bottom and tightening.
- B) Connect vertical extrusions [12 and 12A] to leg assemblies [10 and 11] using vertical connection bar as shown.
- C) Connect upper horizontal extrusion [13] between verticals [12 and 12A] placing it about one inch down from top.

**NOTE: Make sure the lock is flush with extrusion before tightening. If lock will not fully engage, gently rock lock and extrusion back and forth while turning knob until lock fully opens.**

Rear View of Display

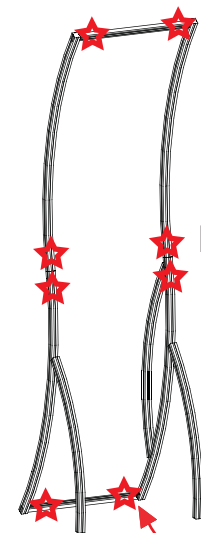

STAR indicates location of knobs on BACKSIDE of unit.

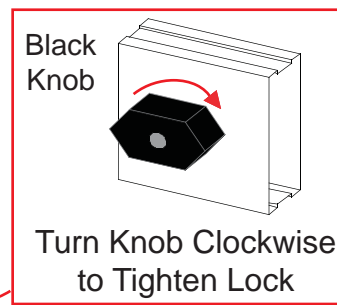

Turn Knob Clockwise to Tighten Lock

**Step 1**

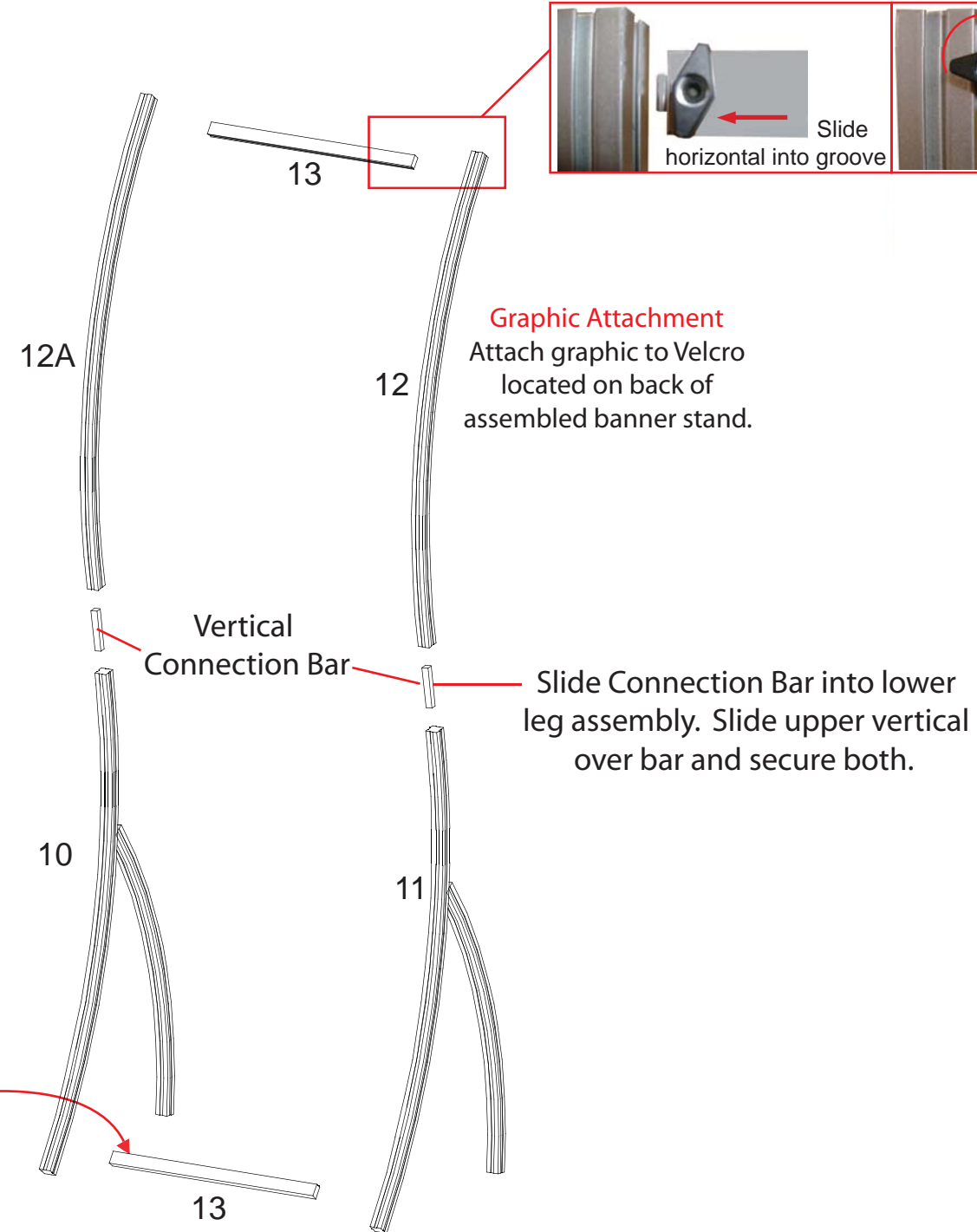

NOTE: When assembling horizontals they should be placed approximately one inch from TOP and BOTTOM.



**Graphic Attachment**  
Attach graphic to Velcro located on back of assembled banner stand.

**WHEN DISASSEMBLING ALUMINUM EXTRUSION, TIGHTEN ALL SETSCREWS AND LOCKS TO PREVENT LOSS DURING SHIPPING**

Attach Header to Banner Station using standoff caps as shown.

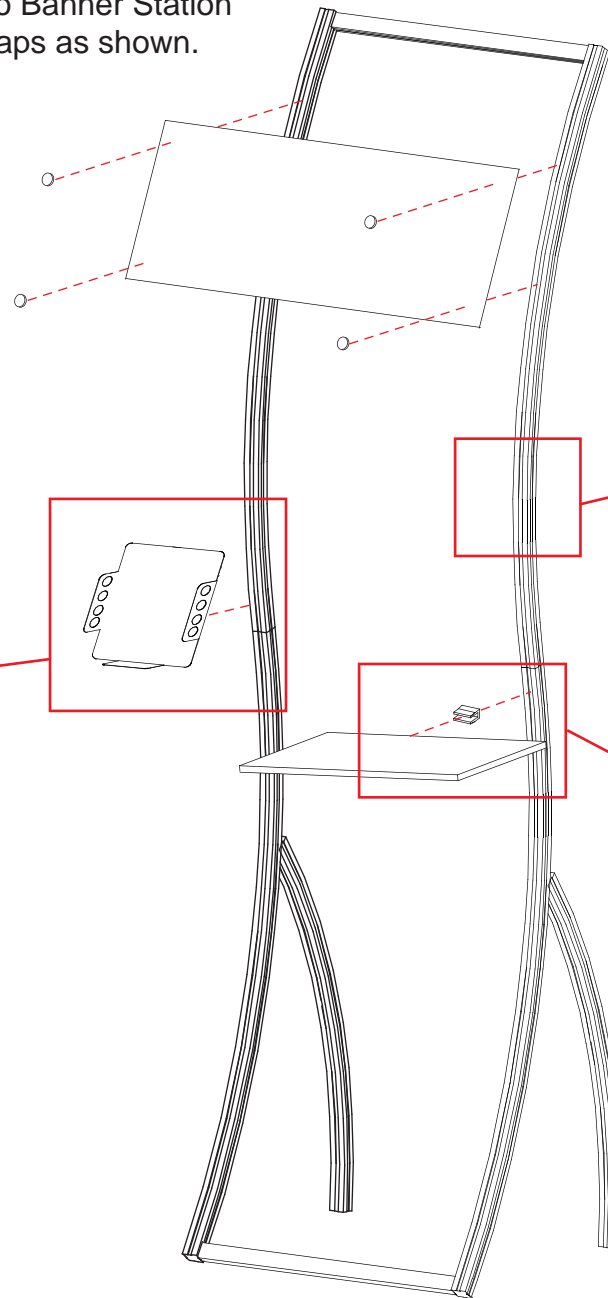

**Literature Rack Attachment**

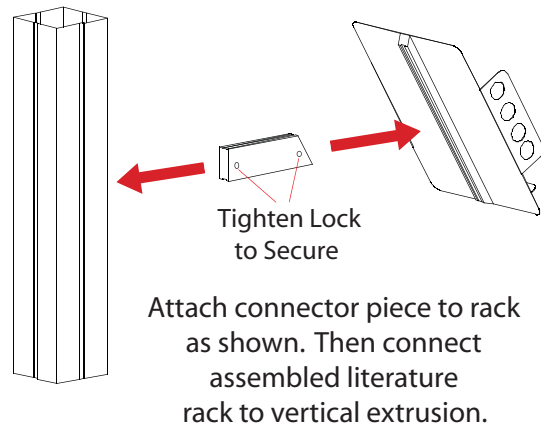

**Monitor Mount Attachment**

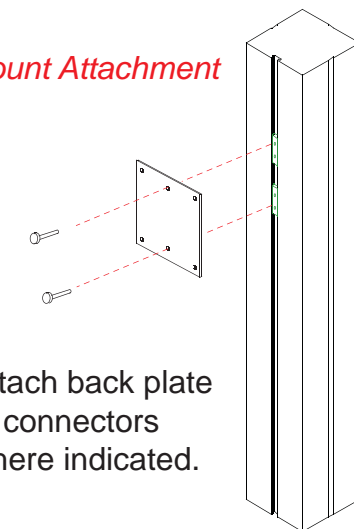

**Shelf Attachment**

Slide A10 Clamp into groove of square extrusion.



When desired location is found, tighten set screw to secure.



Tighten black plastic set screw to secure shelf in place.



Hex Key Tool



(if necessary)

Flathead Screwdriver



**WHEN DISASSEMBLING ALUMINUM EXTRUSION, TIGHTEN ALL SETSCREWS AND LOCKS TO PREVENT LOSS DURING SHIPPING**

Case #1 - Banner Stand Components

Top View of each Level

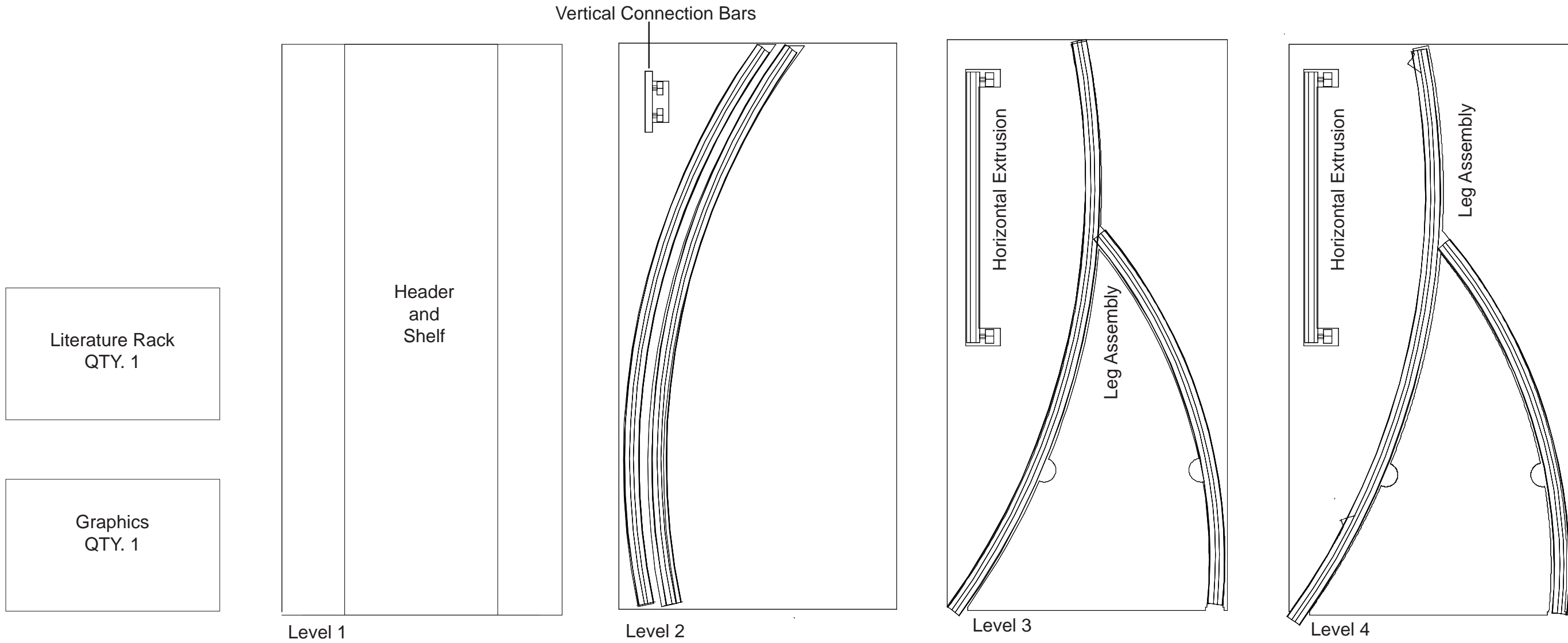

WHEN DISASSEMBLING ALUMINUM EXTRUSION, TIGHTEN ALL SETSCREWS AND LOCKS TO PREVENT LOSS DURING SHIPPING