

visionary[™]
DESIGNS

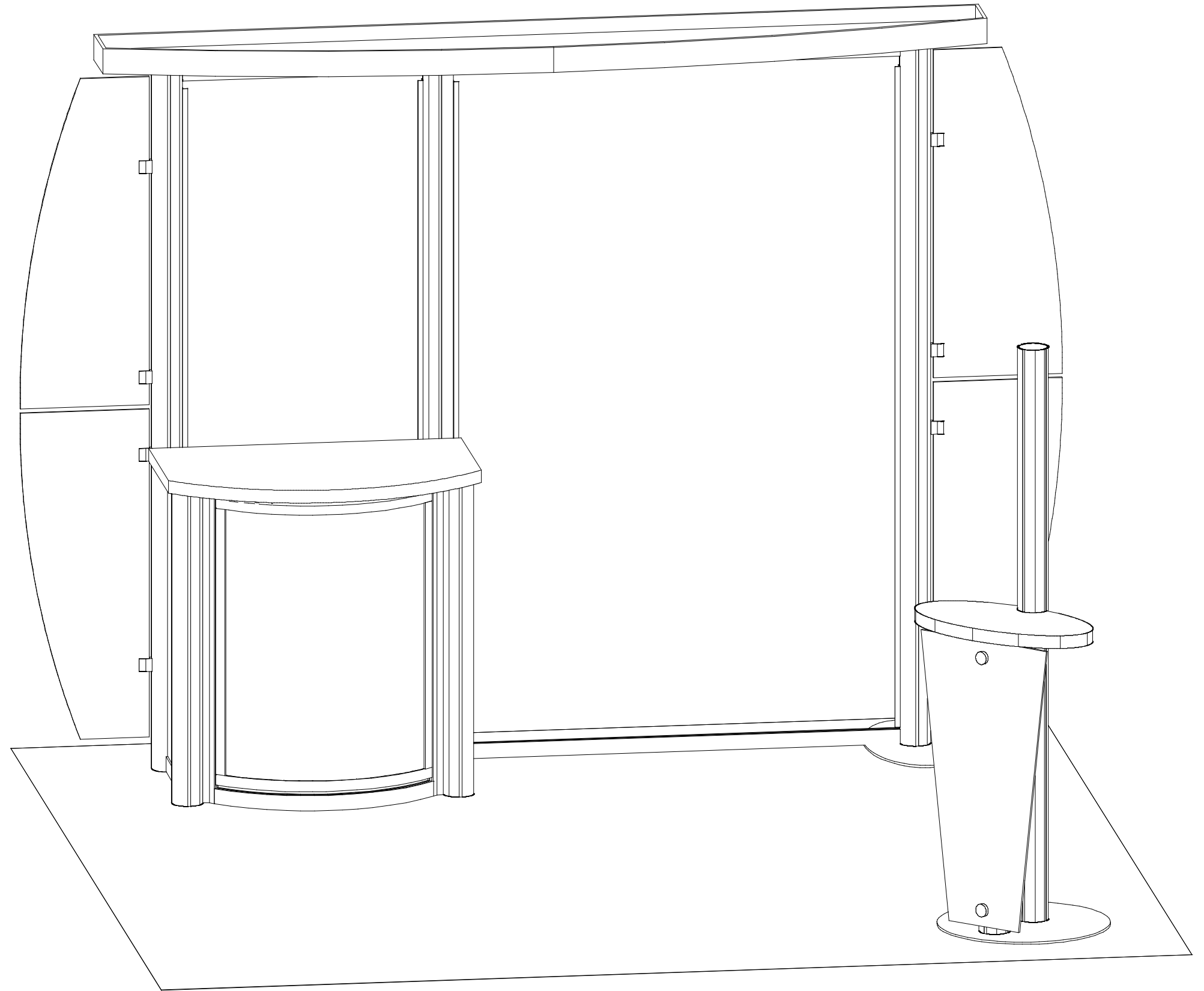
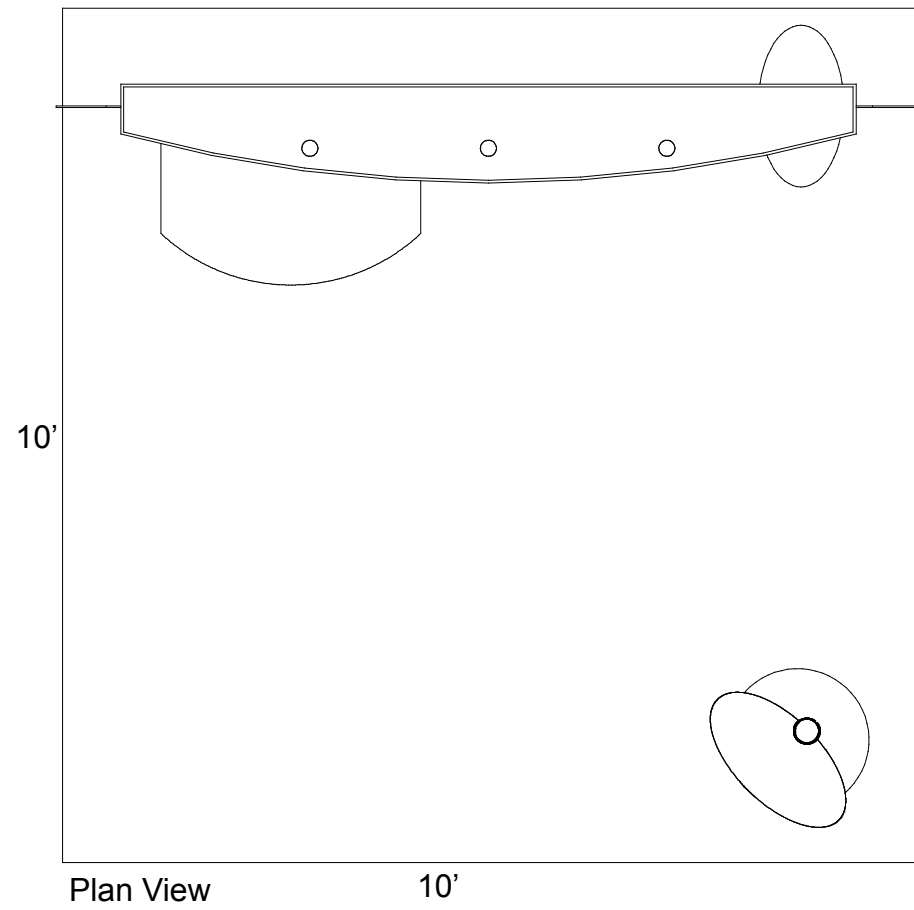

WHEN DISASSEMBLING ALUMINUM EXTRUSION, TIGHTEN ALL SETSCREWS AND LOCKS TO PREVENT LOSS DURING SHIPPING

visionary™ IDESIGNS

Using Your Setup Instructions

The Visionary Designs Setup Instructions are created specifically for your configuration. They are laid out sequentially, including an exploded view of the entire display, and then a logical series of detailed steps to assemble the main structure and components. We encourage you to study the instructions **before** attempting to assemble your exhibit.

Each page reminds you to tighten the setscrews after disassembling your exhibit to prevent loss of the locks and setscrews (see below in RED). This is **VERY IMPORTANT**.

Cleaning and Packing Your Display

- 1) Use care when cleaning aluminum extrusion or acrylic inserts. Use only non-abrasive cleaners.
- 2) When cleaning laminate inserts or countertops, use mild cleansers and a soft material such as cotton.
- 3) Keep all display components away from extreme heat and long exposure to sunlight to avoid warping and fading.
- 4) Retain all packing material. It will make re-packing much easier and will reduce the likelihood of shipping damage.



The Tool

Most Visionary Designs exhibits can be assembled with the supplied Hex Key Tool. Occasionally, a flat head screwdriver may be required.



Typical Connection

Most horizontal extrusion connections have a patented expandable lock. This lock inserts into the groove of an opposing extrusion. Tightening the lock with the Hex Key Tool expands the lock and creates a strong positive connection.



Typical Connection (cont'd)

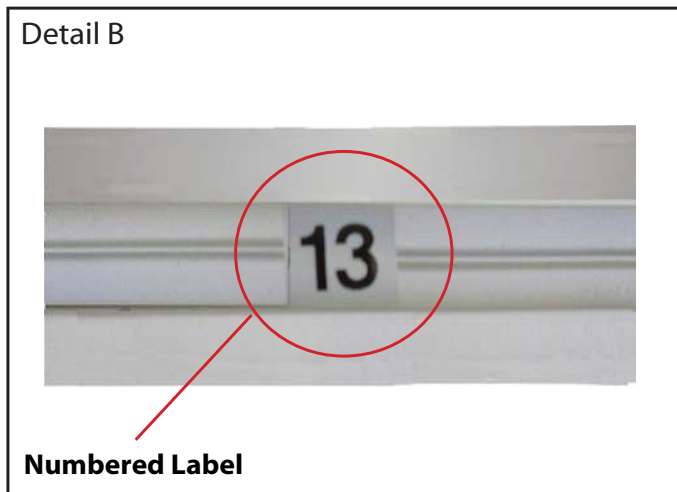

Detail B

Numbered Label

Each extrusion contains a numbered label which corresponds with setup instructions. The label is located within a groove of the extrusion (when possible). With Visionary Designs the labels contain Black numbers unless otherwise specified.



Detail C

Horizontal Inline Connection (remove only one setscrew)

Remove only (1) setscrew when disassembling. Replace setscrew in extrusion after assembling it. Before packing, replace setscrew in extrusion to avoid losing it.

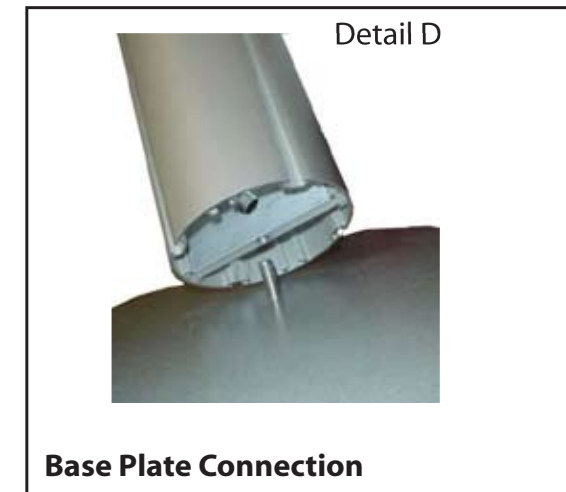

Detail D

Base Plate Connection

Attach base plate to round or square vertical extrusion using the bolt provided. Be careful not to strip the threads.

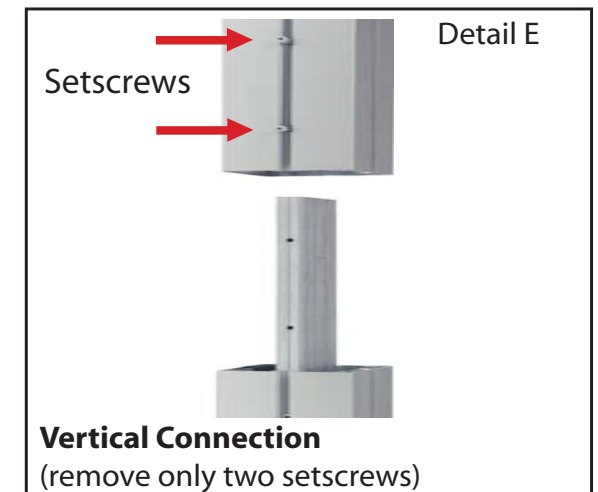

Detail E

Vertical Connection
(remove only two setscrews)

When vertical extrusions are packed in portable cases rather than crates or tubs, they must be broken down into smaller sections which then require assembly.

Remove only (2) setscrews when disassembling. Replace setscrews in extrusion after assembling it. Before packing, replace setscrews in extrusion to avoid losing them.

WHEN DISASSEMBLING ALUMINUM EXTRUSION, TIGHTEN ALL SETSCREWS AND LOCKS TO PREVENT LOSS DURING SHIPPING

866.652.2100

Item	Qty.	Description
1	1	Oval Base Plates
2	1	84" h Vertical Extrusion w/ Canopy Attachment
3	1	84" h Vertical Extrusion
4	1	83.75" h Vertical Extrusion w/ Canopy Attachment
5A/5B	1/1	28" Horizontal Extrusion
6A/6B	1/1	52" Horizontal Extrusion

- Steps**
- 1) Attach Vertical extrusion [4] to the Oval base plate [1].
 - 2) Attach Horizontal extrusions [5A, 5B, 6A and 6B] between vertical extrusions [2, 3 and 4] as shown.

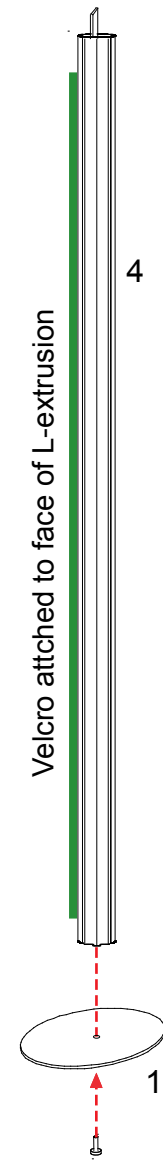
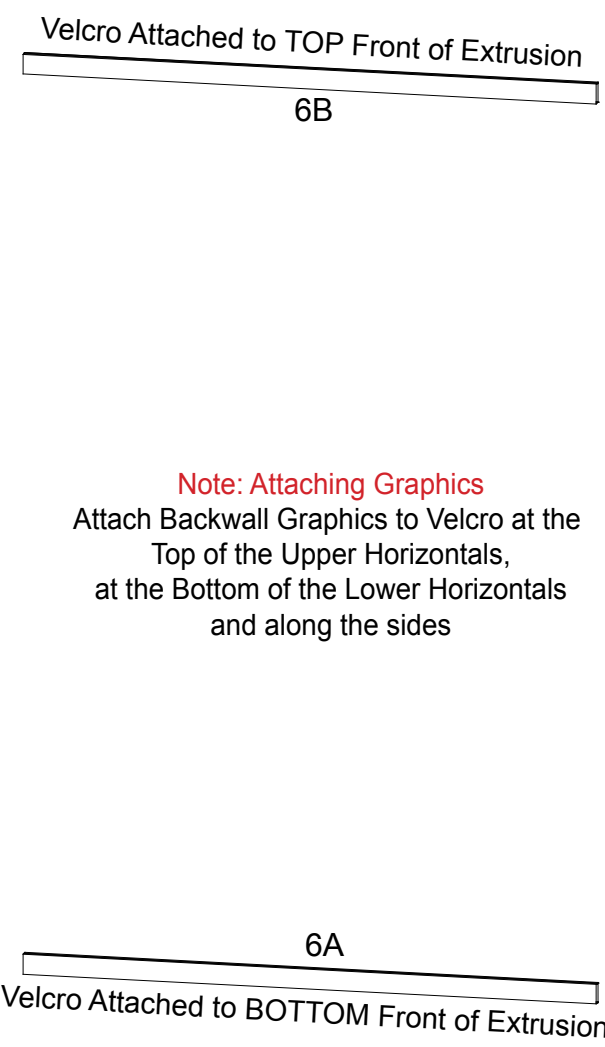
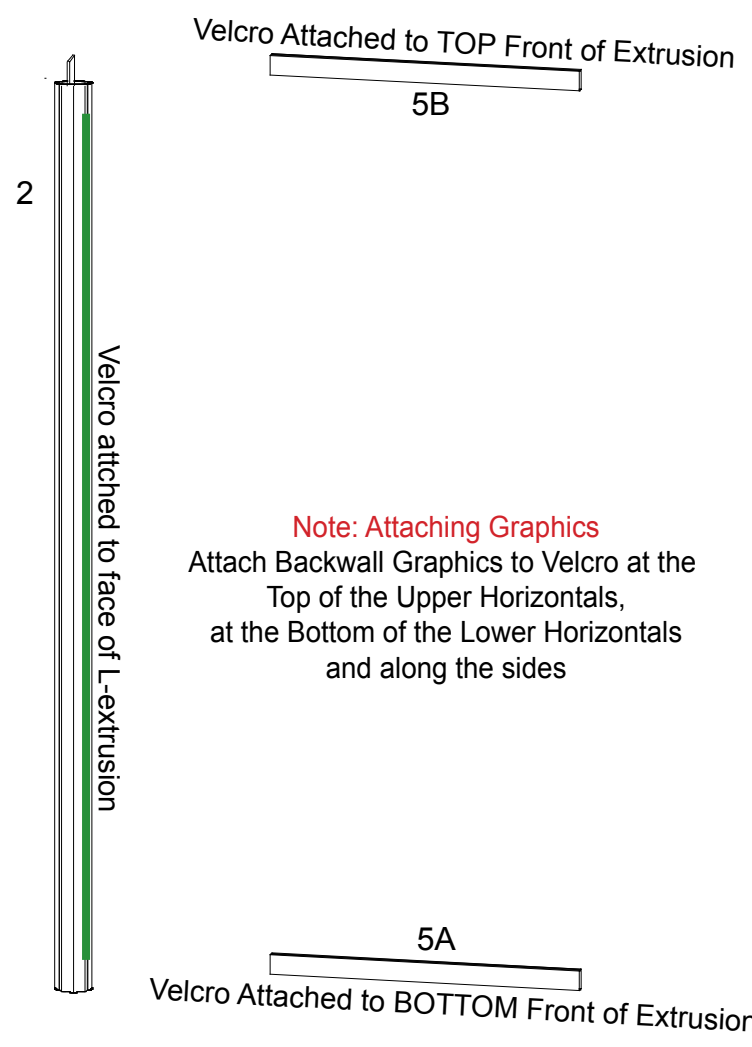
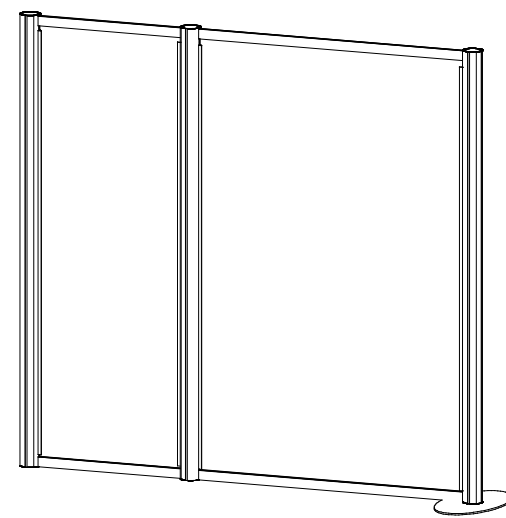

****L-Extrusions are highlighted in GREEN****
 L-Extrusions must stay attached to uprights when shipping.

WHEN DISASSEMBLING ALUMINUM EXTRUSION, TIGHTEN ALL SETSCREWS AND LOCKS TO PREVENT LOSS DURING SHIPPING

866.652.2100

Item	Qty	Description
7	2	38" h Round Vertical Extrusion
8	1	38" h 135° Vertical Extrusion w/ Door Stop
8A	1	38" h 135° Vertical Extrusion w/ Door Hinge
9	4	12.5" w Horizontal Extrusion
10	2	Curved Horizontal Extrusion
	4	Internal Shelf Support

Steps

- 1) Attach 135° extrusions to round vertical extrusions [8 to 7 and 8A to 7] as shown below.
NOTE: Extrusions [7/8 and 7/8A] should remain assembled when shipping.
- 2) Attach lower horizontal extrusions [9 and 10] between vertical extrusions [8 and 8A] as shown.
- 3) Place inserts and door where indicated.
- 4) Attach upper horizontal extrusions [9 and 10] between vertical extrusions [7] as shown.
- 5) Insert internal shelf and set atop velcroed supports.
- 6) Place coner atop assembled pedestal.

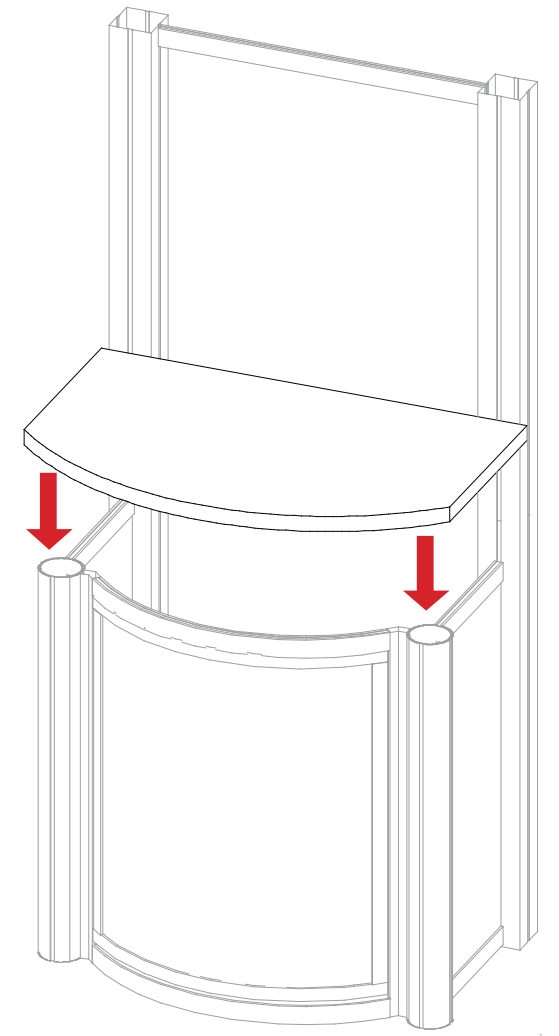
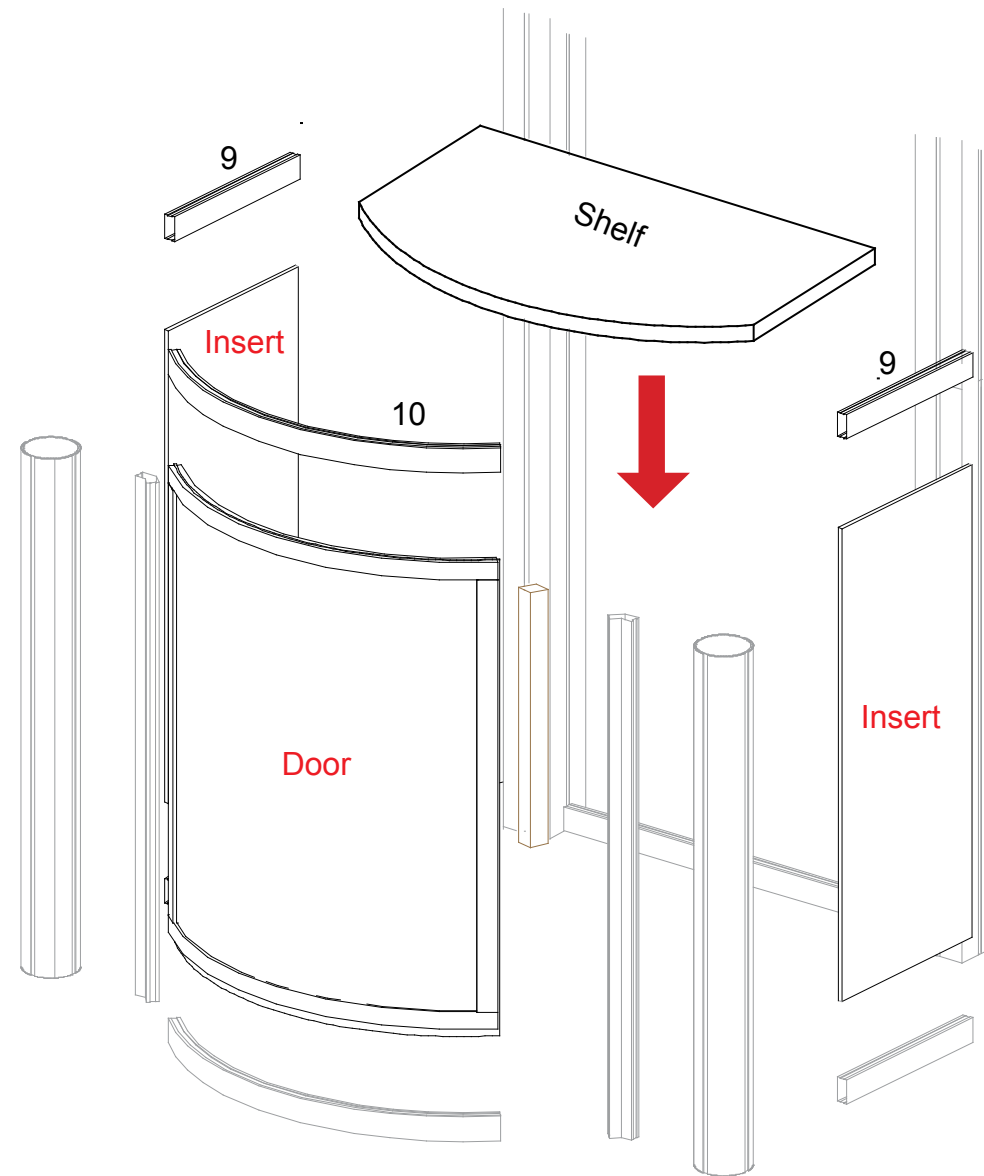
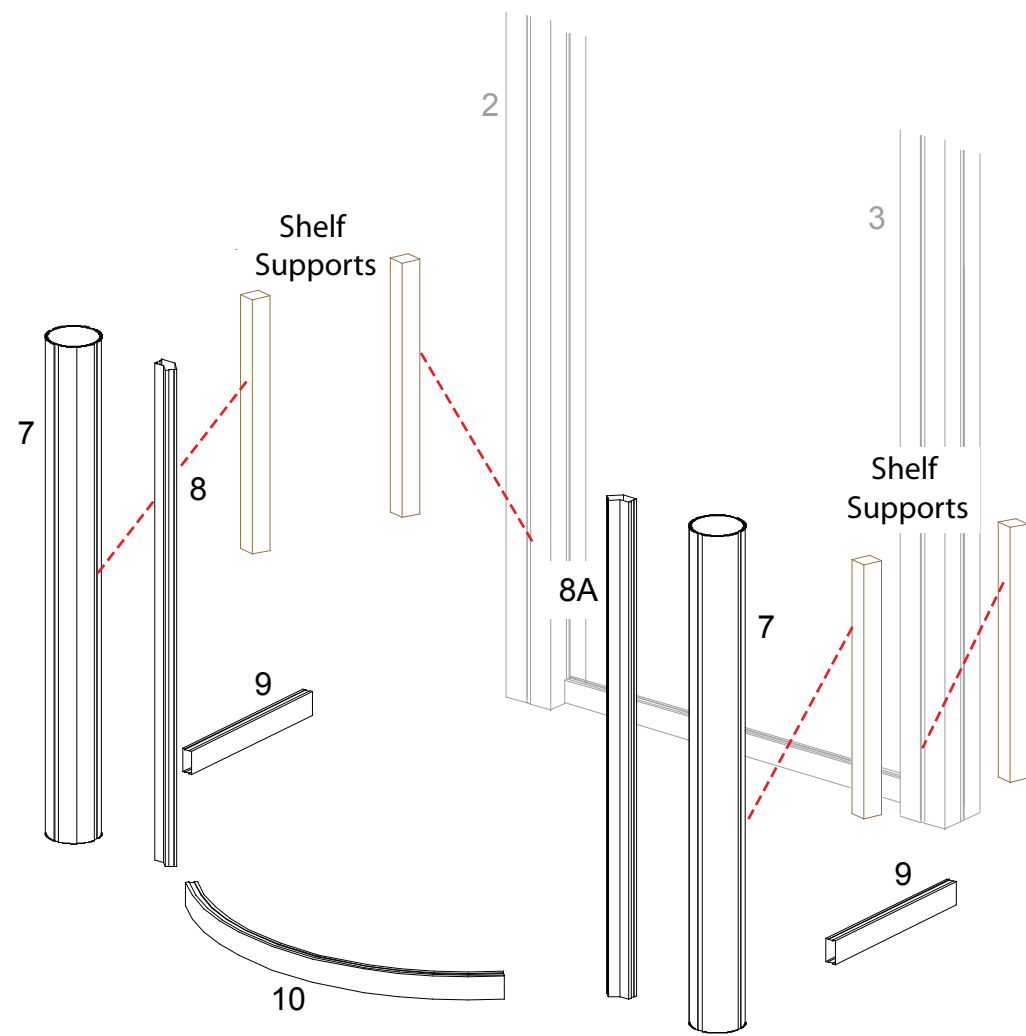
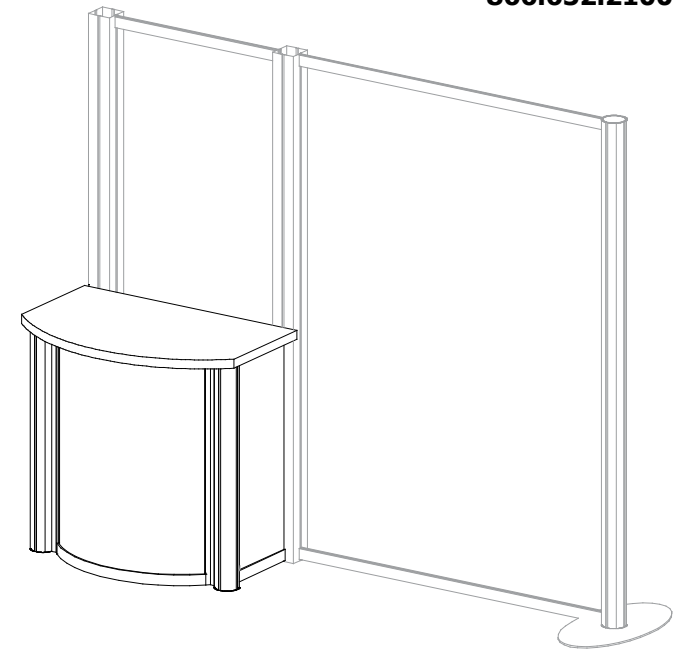

WHEN DISASSEMBLING ALUMINUM EXTRUSION, TIGHTEN ALL SETSCREWS AND LOCKS TO PREVENT LOSS DURING SHIPPING

866.652.2100

Steps

- 1) Attach ceiling to assembled backwall as shown.
- 2) Attach wings using A10 clamps as shown.

Example of Canopy Connection

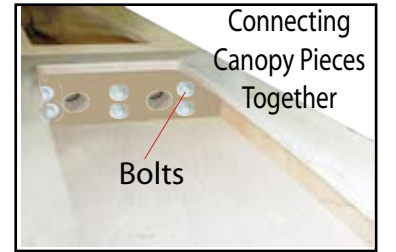

Connect 3 piece Canopy together by using bolts and wing nuts provided.

Wing Attachment

Slide A10 Clamp into groove of square extrusion.

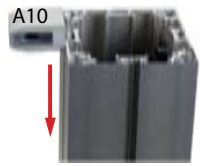

When desired location is found, tighten set screw to secure.



Tighten black plastic set screw to secure Wing in place.

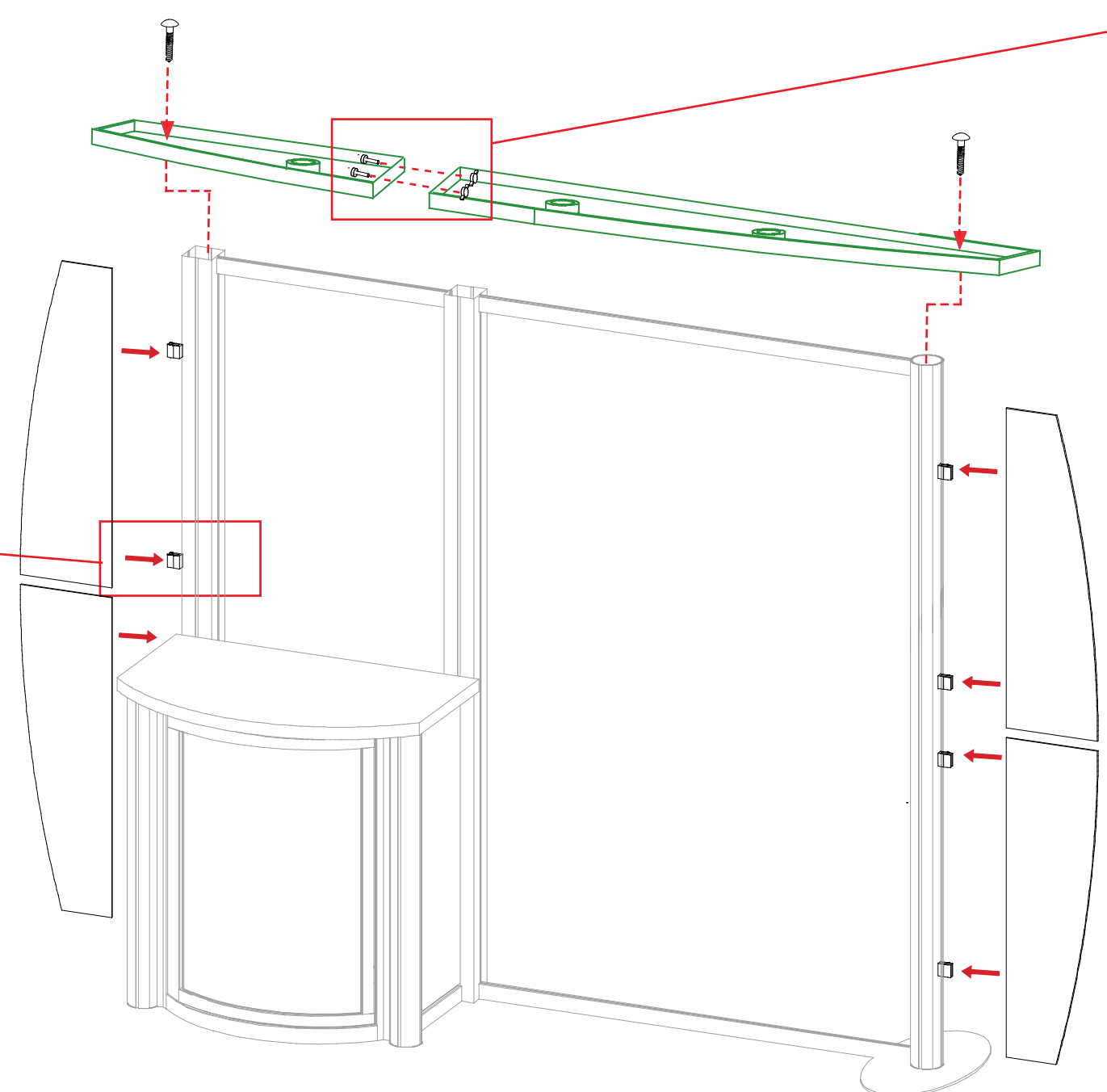

WHEN DISASSEMBLING ALUMINUM EXTRUSION, TIGHTEN ALL SETSCREWS AND LOCKS TO PREVENT LOSS DURING SHIPPING

866.652.2100

Item	Qty.	Description
15	1	18"D Round Base Plate
16	1	68"h Round Vertical Extrusion
17	1	36"h Round Vertical Extrusion

Steps

- 1) Attach vertical extrusions [16 and 17] to base plate [15] as shown.
- 2) Attach tapered plex wing to front of vertical extrusion [17] using standoff caps and round sign to vertical extrusion [16].
- 3) Place and attach counter atop vertical extrusion [17].

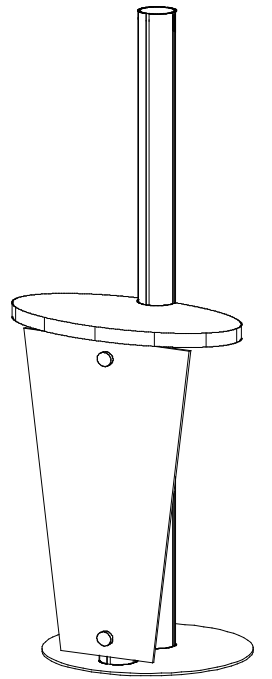
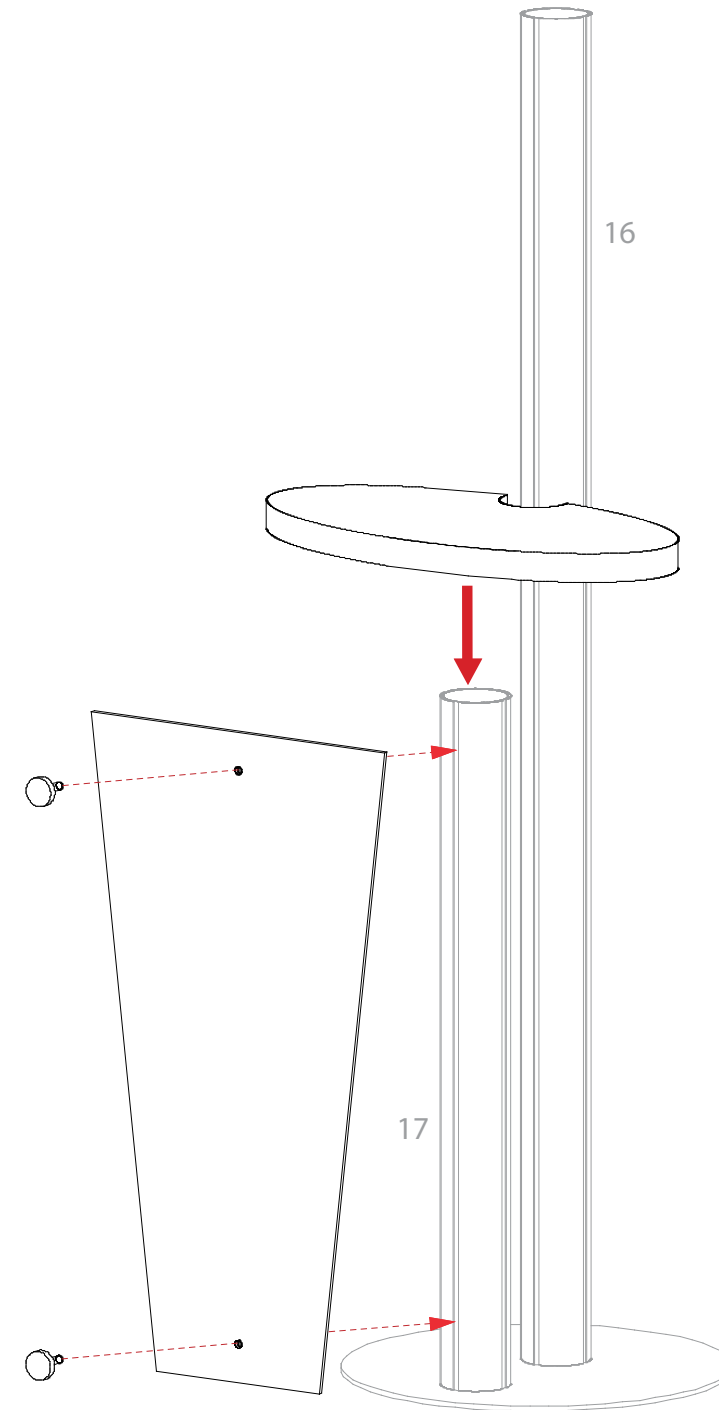
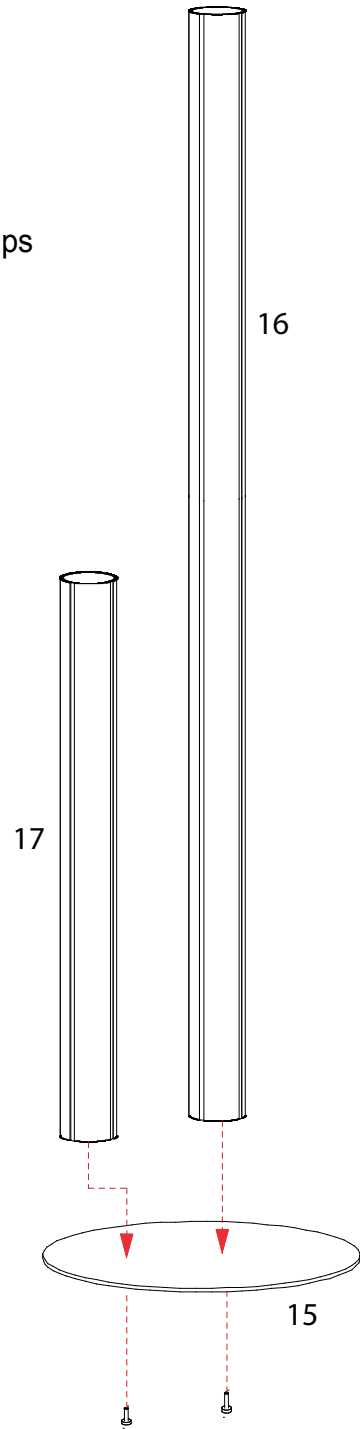

WHEN DISASSEMBLING ALUMINUM EXTRUSION, TIGHTEN ALL SETSCREWS AND LOCKS TO PREVENT LOSS DURING SHIPPING

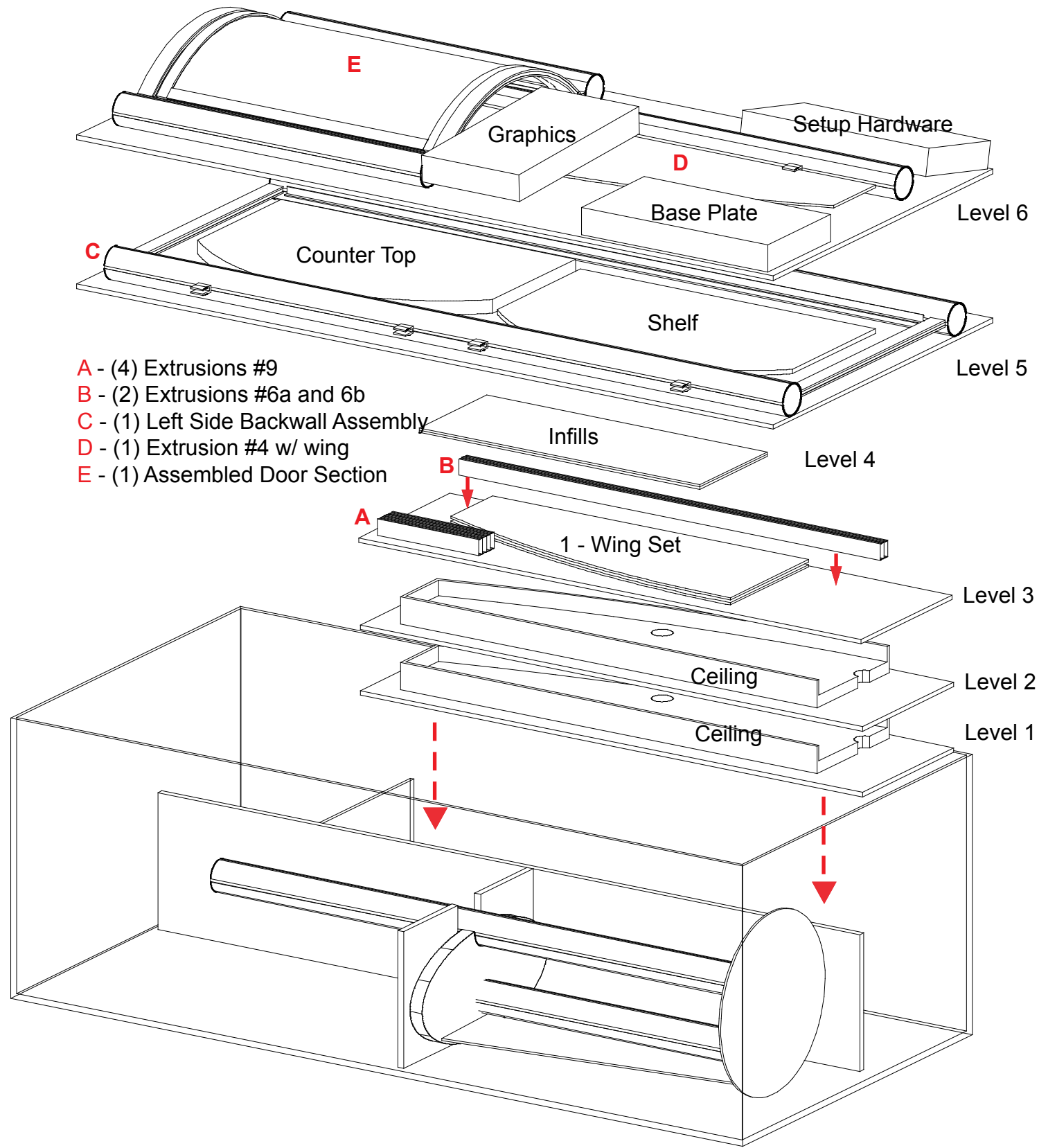

Level 1

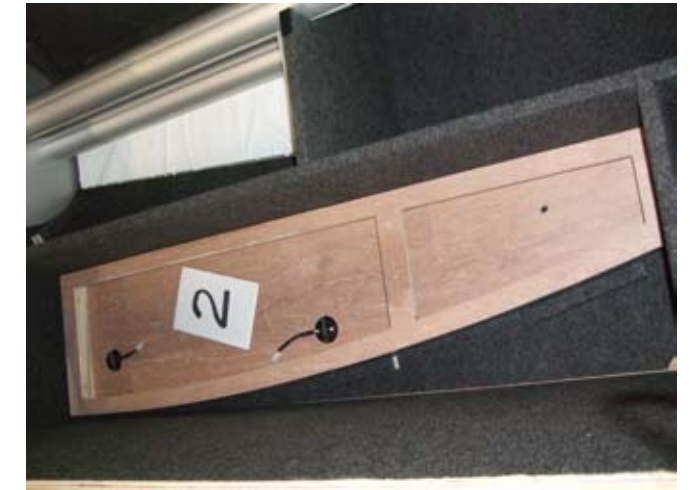

Level 2

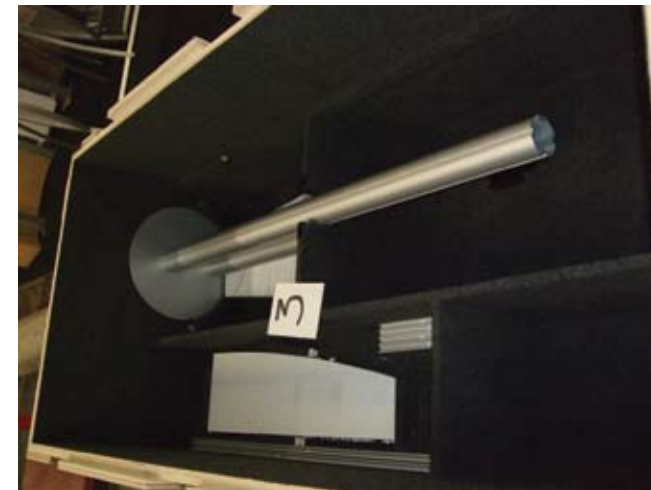

Level 3

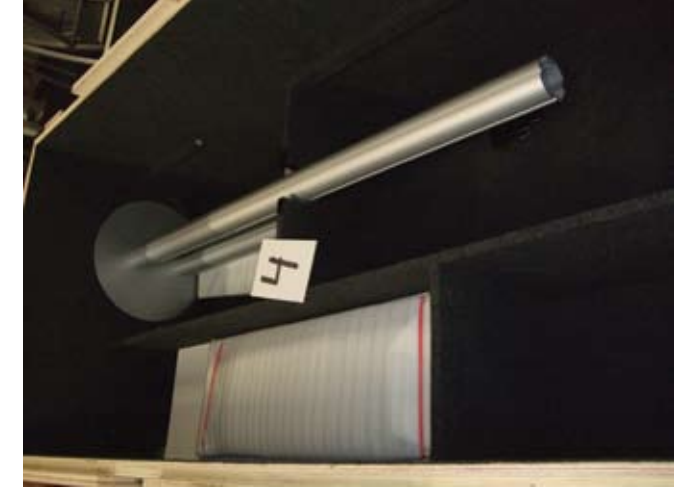

Level 4



Level 5



Level 6

WHEN DISASSEMBLING ALUMINUM EXTRUSION, TIGHTEN ALL SETSCREWS AND LOCKS TO PREVENT LOSS DURING SHIPPING