

# Perfect 10 Hybrid Displays

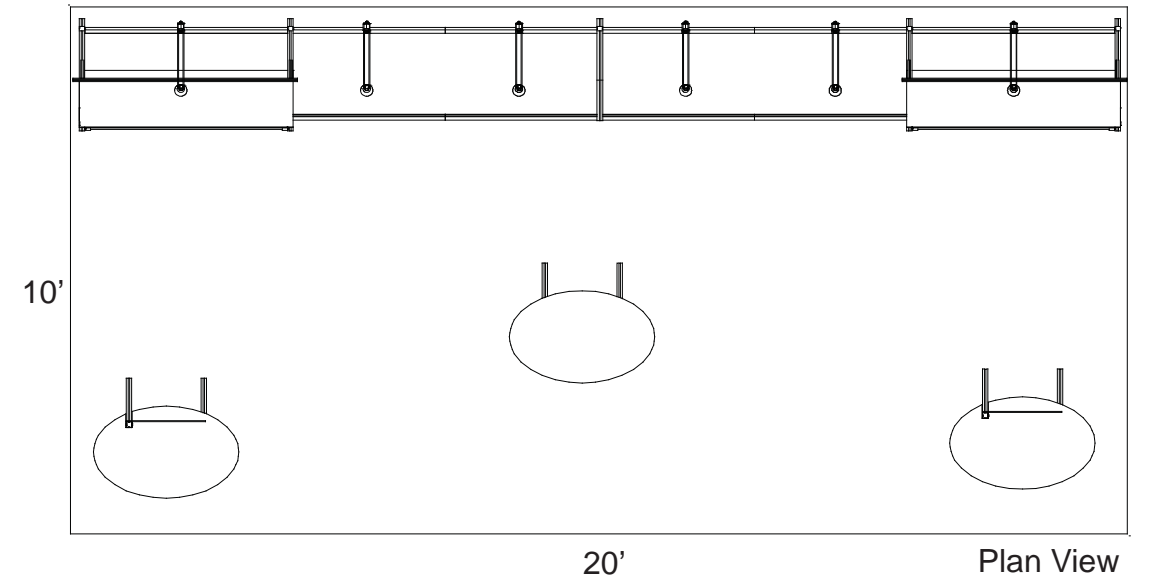
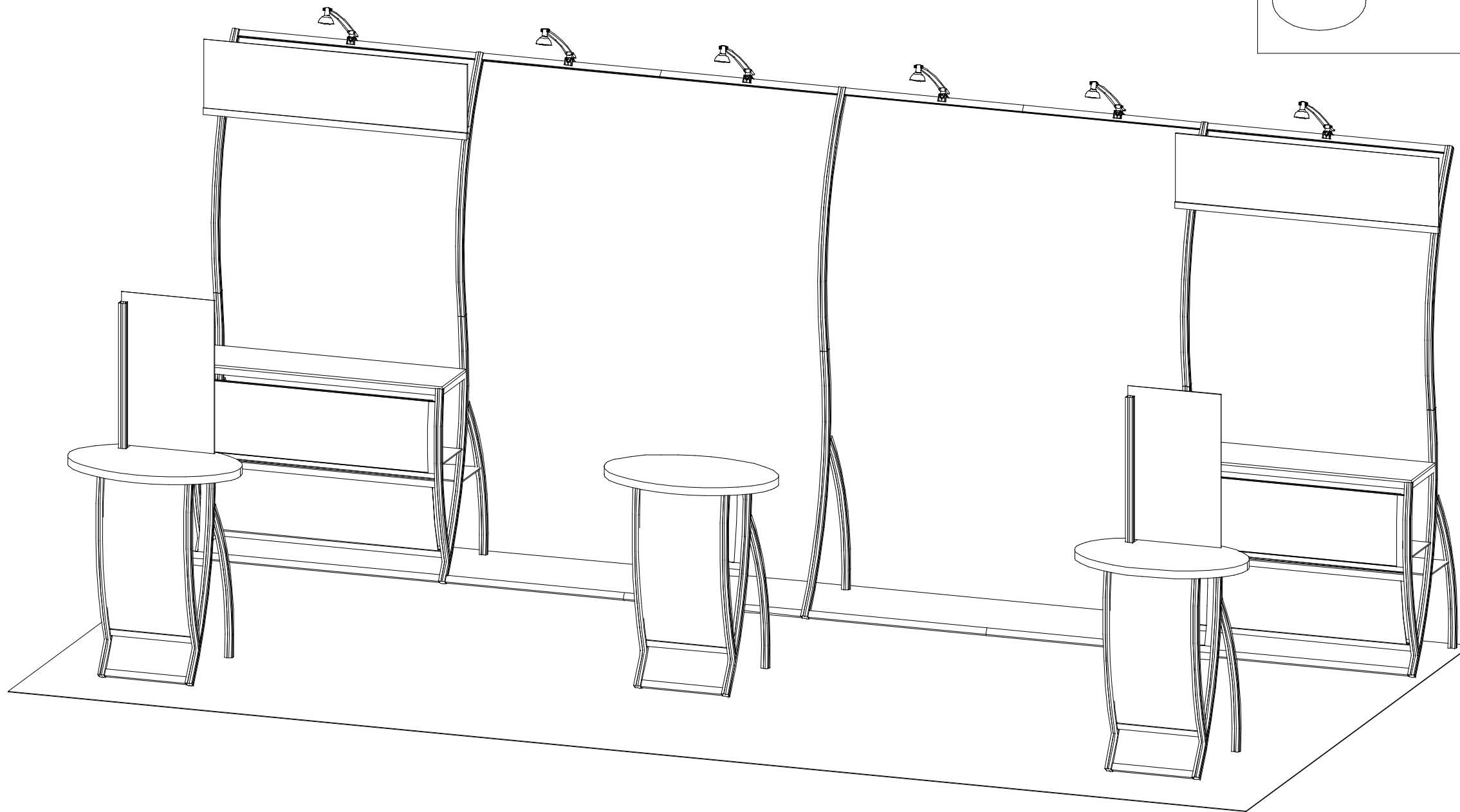

WHEN DISASSEMBLING TIGHTEN ALL KNOBS TO PREVENT LOSS DURING SHIPPING

Part Number	Description
1	Left Leg Assembly
2	Middle Leg Assembly
3	Upper Curved Vertical
4	Upper Curved Vertical
5	46" w Horizontal
6/6a	Side Assembly
7/7a	Side Assembly
8	Lower Horizontal Extrusion
9	Horizontal Extrusion w/ Door Stopper

NOTE: When assembling horizontals they should be placed approximately one inch from TOP and BOTTOM.

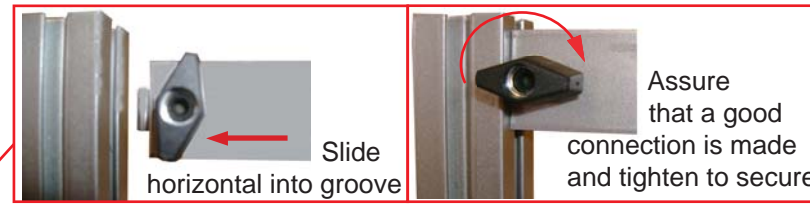

Step 1

Step 1:

NOTE: Can be assembled either face down on floor then lifted upright or upright as shown in drawings.

- A) Connect vertical leg assemblies [1 and 2] together by connecting horizontal extrusions [5] between assemblies tightening BLACK knobs on backside of extrusion making sure Velcro faces toward BACK and placing it about one inch up from bottom and tightening.
- B) Connect vertical extrusions [3 and 4] to leg assemblies [1 and 2] using vertical connection bar as shown.
- C) Connect upper horizontal extrusion [5] between verticals [3 and 4] placing it atop stoppers.
- D) Attach side assemblies [6/6a and 7/7a] to leg assemblies [1 and 2] then connect horizontal extrusion [8] into grooves of curve extrusions [6 and 7].
- E) Slide infill between curve extrusions [6 and 7] and atop extrusion [8].
- F) Attach extrusion door between curve extrusions [6 and 7] and atop infill.
- G) Attach upper horizontal extrusion [9] between curve extrusions [6 and 7] and atop door.

NOTE: Make sure the lock is flush with extrusion before tightening. If lock will not fully engage, gently rock lock and extrusion while turning knob until lock fully opens.

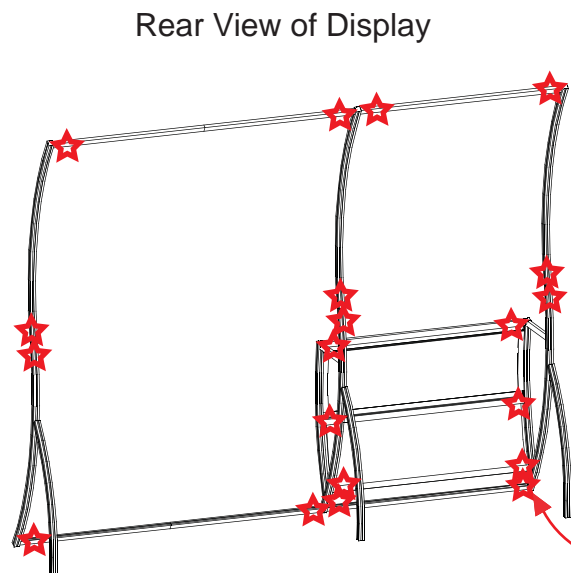

Rear View of Display

STAR indicates location of knobs on BACKSIDE of unit.

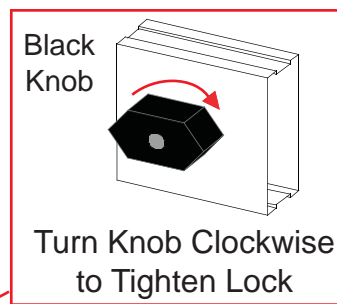

Extrusions 6&6a and 7&7a must stay assembled when shipping in case

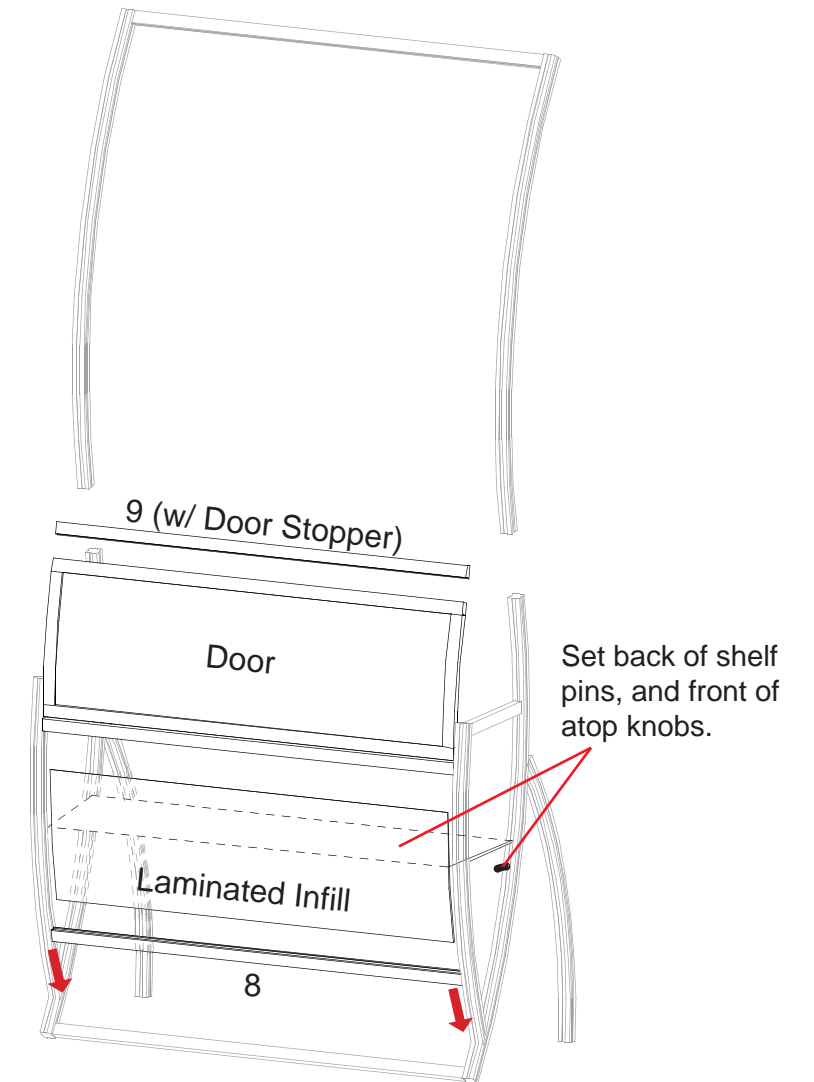
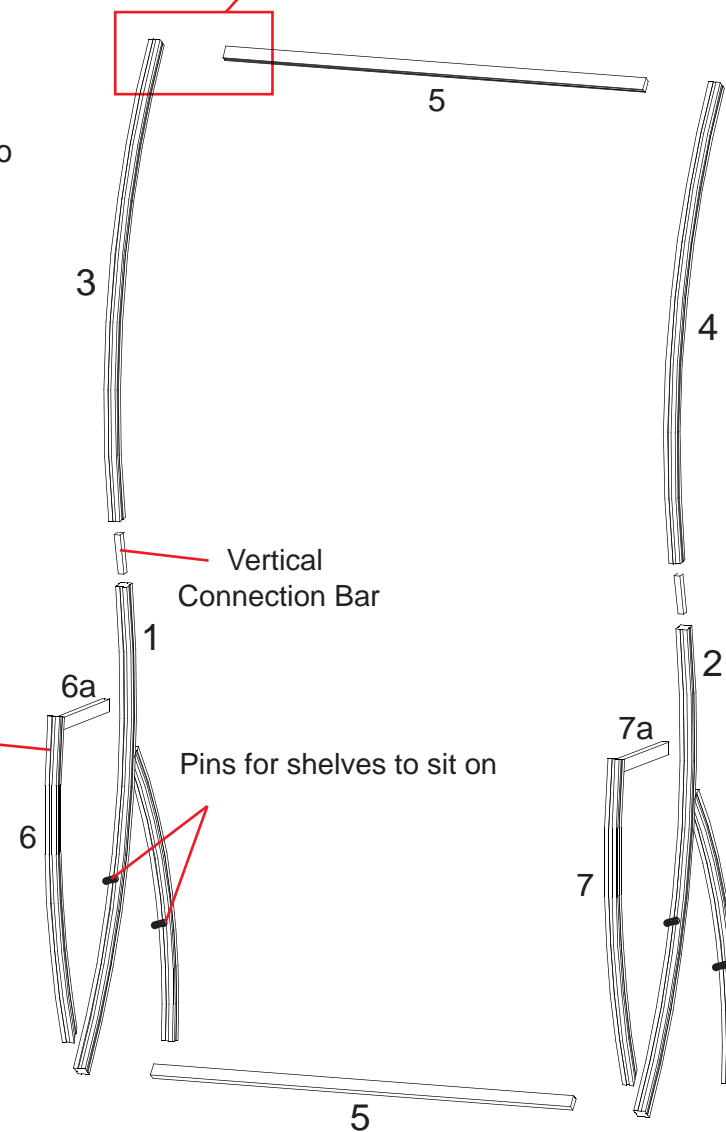

WHEN DISASSEMBLING TIGHTEN ALL KNOBS TO PREVENT LOSS DURING SHIPPING

Part Number	Description
10	Middle Leg Assembly
11	Upper Curved Vertical
12	69" w Horizontal w/ Hinge Facing UP
13	69" w Horizontal w/ Hinge Facing DOWN

NOTE: When assembling horizontals they should be placed approximately one inch from TOP and BOTTOM.

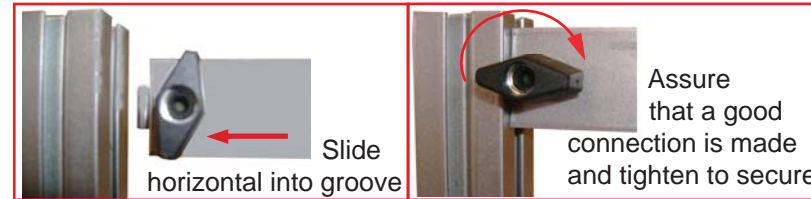

Step 2:

NOTE: Can be assembled either face down on floor then lifted upright or upright as shown in drawings.

- A) Connect vertical extrusion [11] to leg assembly [10] using vertical connection bar as shown.
- B) Connect horizontal extrusions [12 and 13] between vertical assemblies by tightening BLACK knobs on backside of extrusion making sure Velcro faces toward BACK.

NOTE: Make sure the lock is flush with extrusion before tightening. If lock will not fully engage, gently rock lock and extrusion while turning knob until lock fully opens.

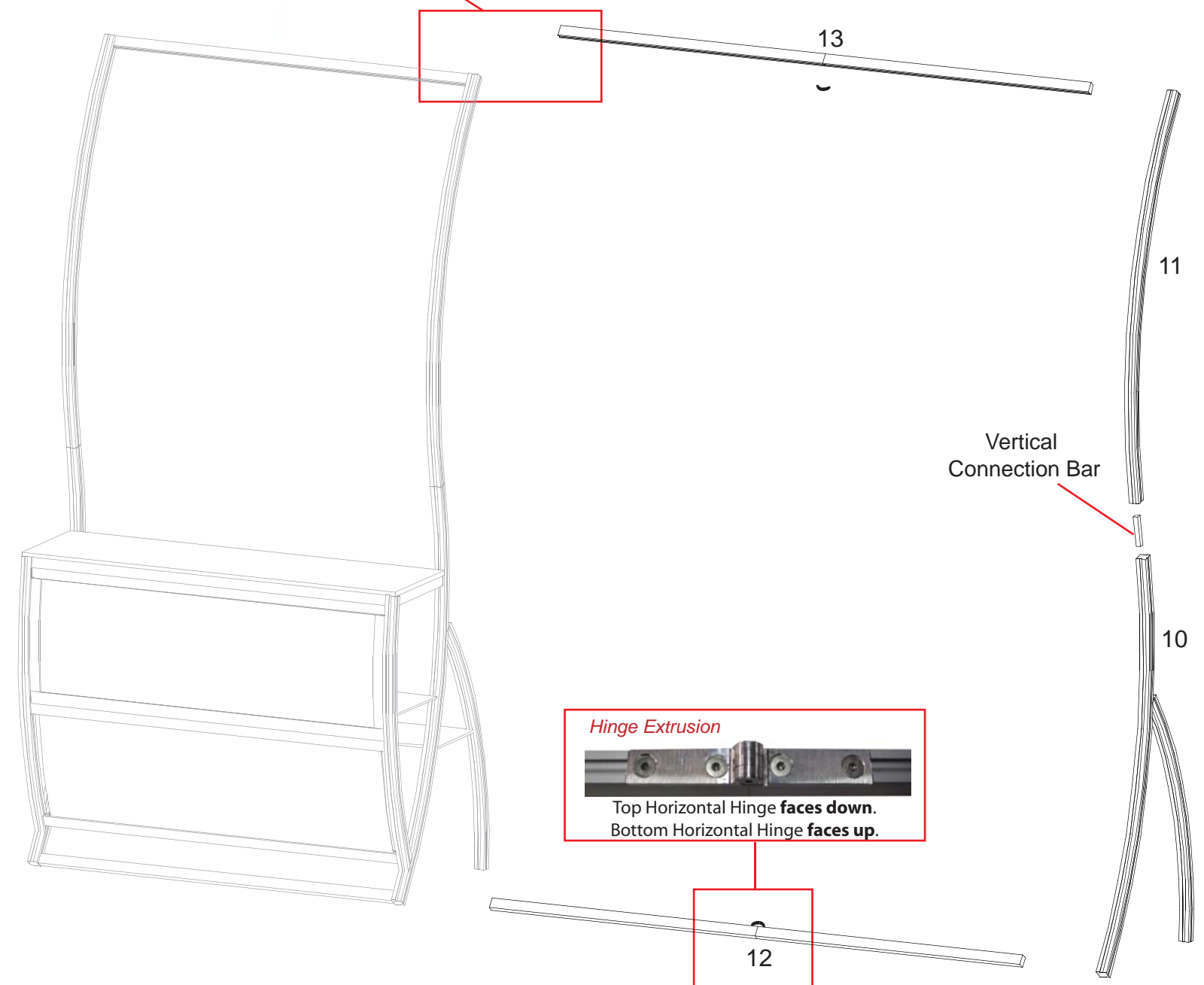

Rear View of Display

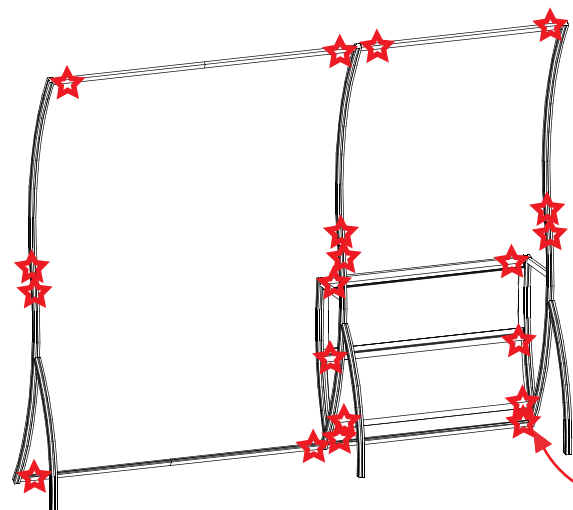

STAR indicates location of knobs on BACKSIDE of unit.

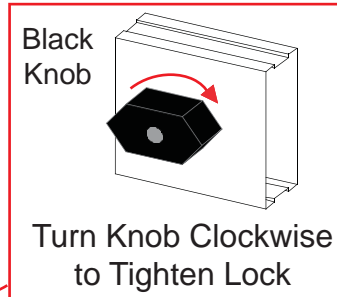

WHEN DISASSEMBLING TIGHTEN ALL KNOBS TO PREVENT LOSS DURING SHIPPING

Part Number	Description
14	Middle Leg Assembly
15	Upper Curved Vertical
16	69" w Horizontal w/ Hinge Facing UP
17	69" w Horizontal w/ Hinge Facing DOWN

NOTE: When assembling horizontals they should be placed approximately one inch from TOP and BOTTOM.

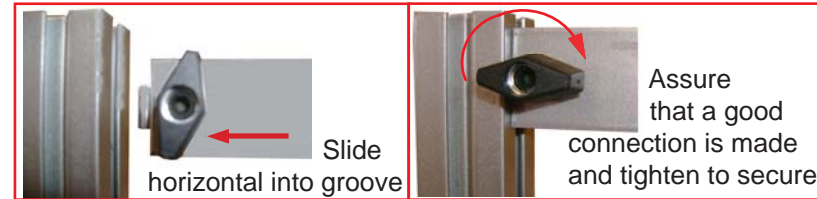

Step 3

Step 3:

NOTE: Can be assembled either face down on floor then lifted upright or upright as shown in drawings.

- A) Connect vertical extrusion [15] to leg assembly [14] using vertical connection bar as shown.
- B) Connect horizontal extrusions [16 and 17] between vertical assemblies by tightening BLACK knobs on backside of extrusion making sure Velcro faces toward BACK.

NOTE: Make sure the lock is flush with extrusion before tightening. If lock will not fully engage, gently rock lock and extrusion while turning knob until lock fully opens.

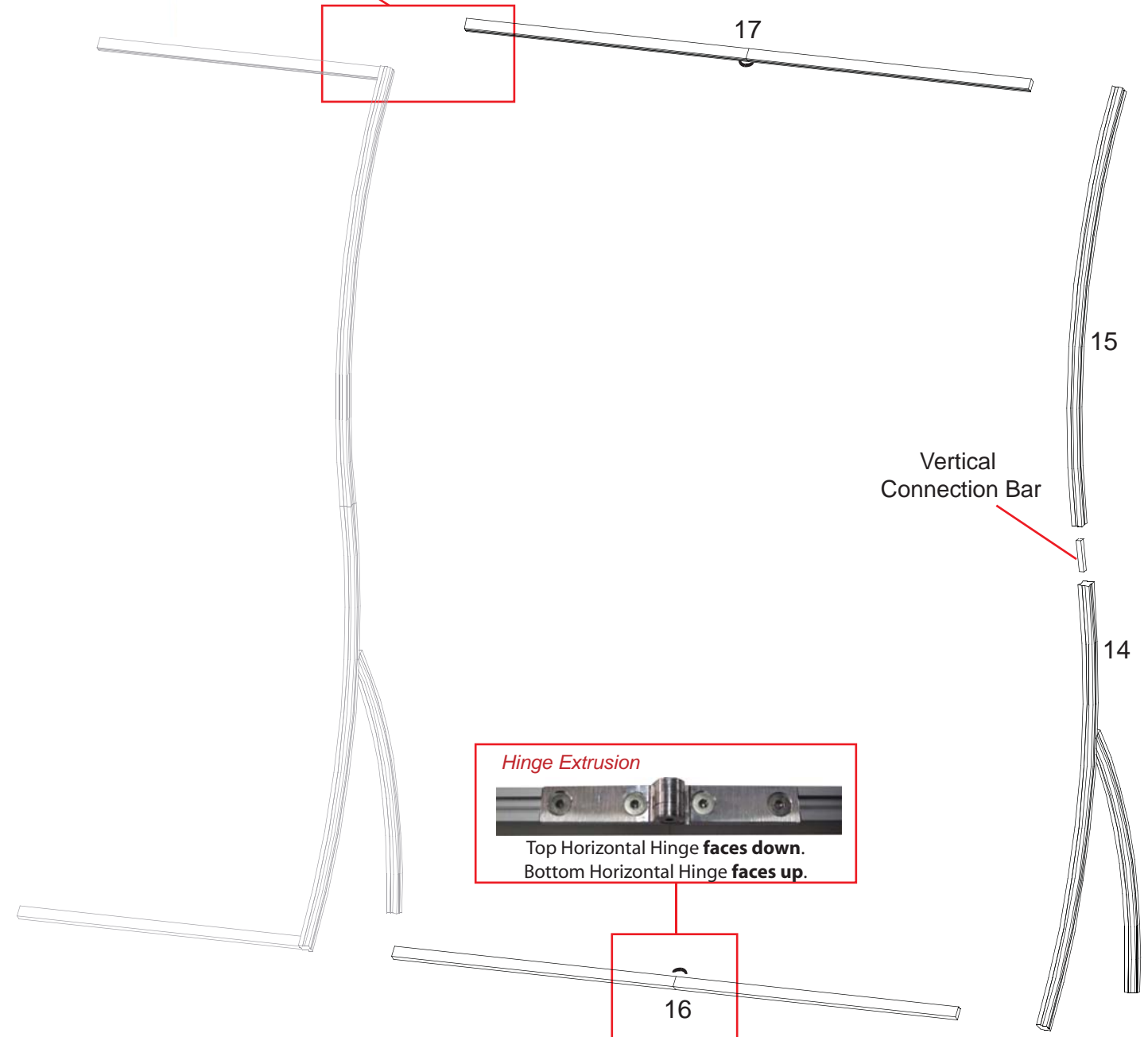

Rear View of Display

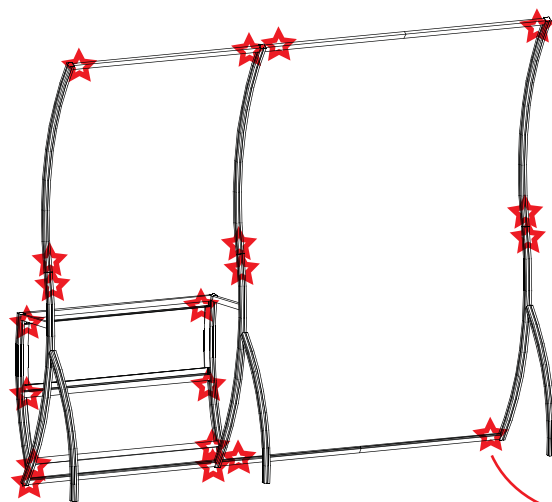

STAR indicates location of knobs on BACKSIDE of unit.

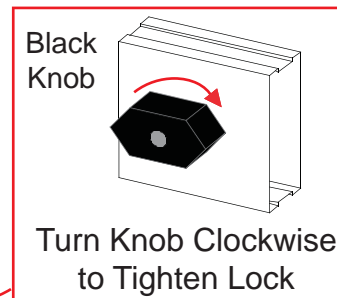

WHEN DISASSEMBLING TIGHTEN ALL KNOBS TO PREVENT LOSS DURING SHIPPING

Part Number	Description
18	Right Leg Assembly
19	Upper Curved Vertical
20	46" w Horizontal
21/21a	Side Assembly
22/22a	Side Assembly
23	Lower Horizontal Extrusion
24	Horizontal Extrusion w/ Door Stopper

NOTE: When assembling horizontals they should be placed approximately one inch from TOP and BOTTOM.

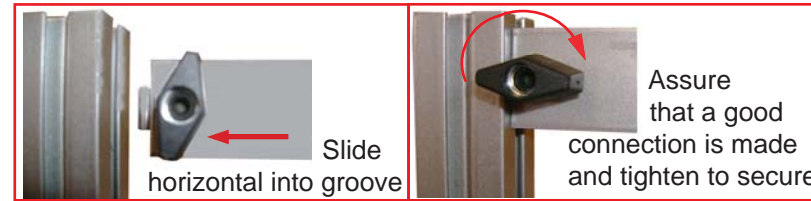

Step 3:  
NOTE: Can be assembled either face down on floor then lifted upright or upright as shown in drawings.

- A) Connect vertical leg assemblies [14 and 18] together by connecting horizontal extrusions [20] between assemblies tightening BLACK knobs on backside of extrusion making sure Velcro faces toward BACK and placing it about one inch up from bottom and tightening.
- B) Connect vertical extrusions [19] to leg assemblies [18] using vertical connection bar as shown.
- C) Connect upper horizontal extrusion [20] between verticals [15 and 19] placing it atop stoppers.
- D) Attach side assemblies [21/21a and 22/22a] to leg assemblies [14 and 18] then connect horizontal extrusion [23] into grooves of curve extrusions [21 and 22].
- E) Slide infill between curve extrusions [6 and 7] and atop extrusion [8].
- F) Attach extrusion door between curve extrusions [6 and 7] and atop infill.
- G) Attach upper horizontal extrusion [9] between curve extrusions [6 and 7] and atop door.

NOTE: Make sure the lock is flush with extrusion before tightening. If lock will not fully engage, gently rock lock and extrusion while turning knob until lock fully opens.

Step 4

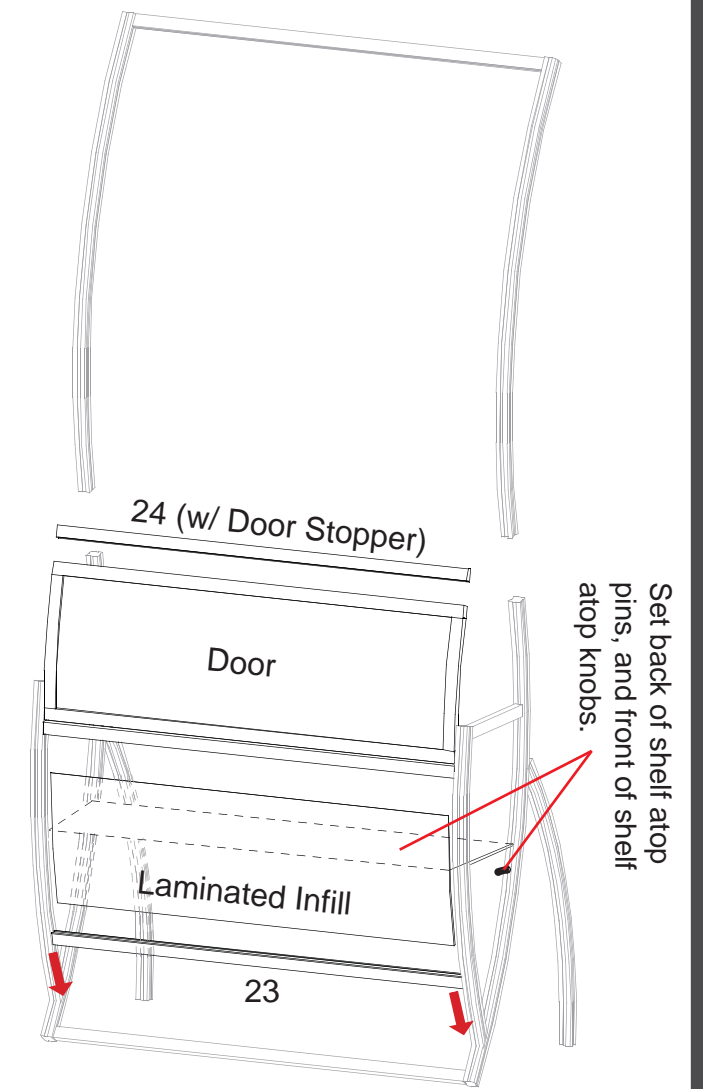
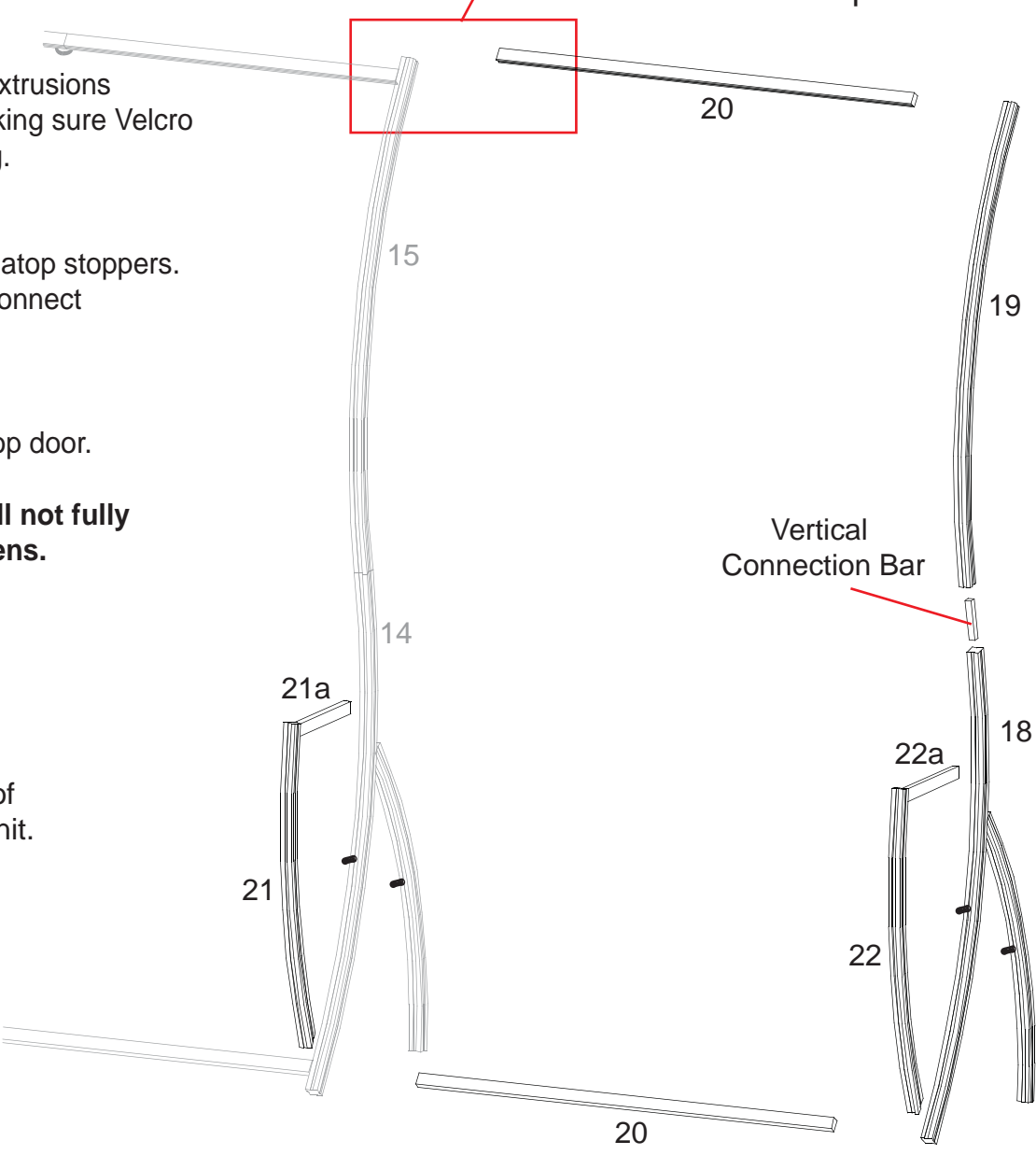

Rear View of Display

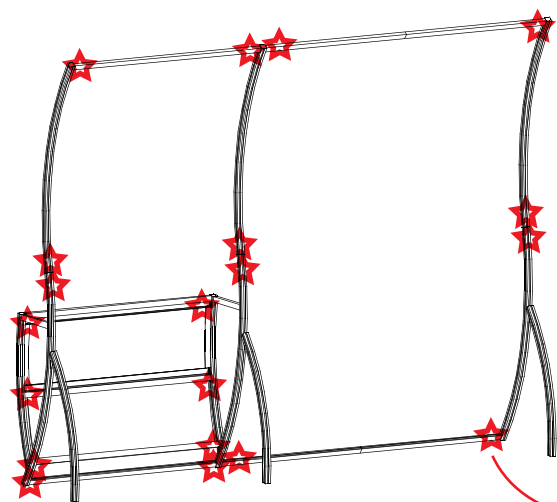

STAR indicates location of knobs on BACKSIDE of unit.

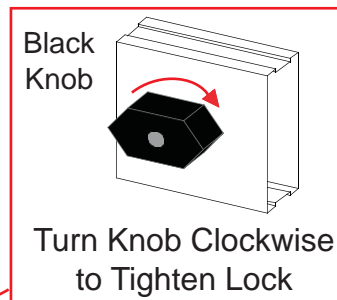

WHEN DISASSEMBLING TIGHTEN ALL KNOBS TO PREVENT LOSS DURING SHIPPING

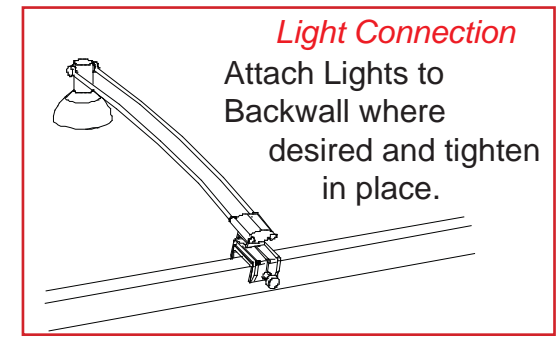
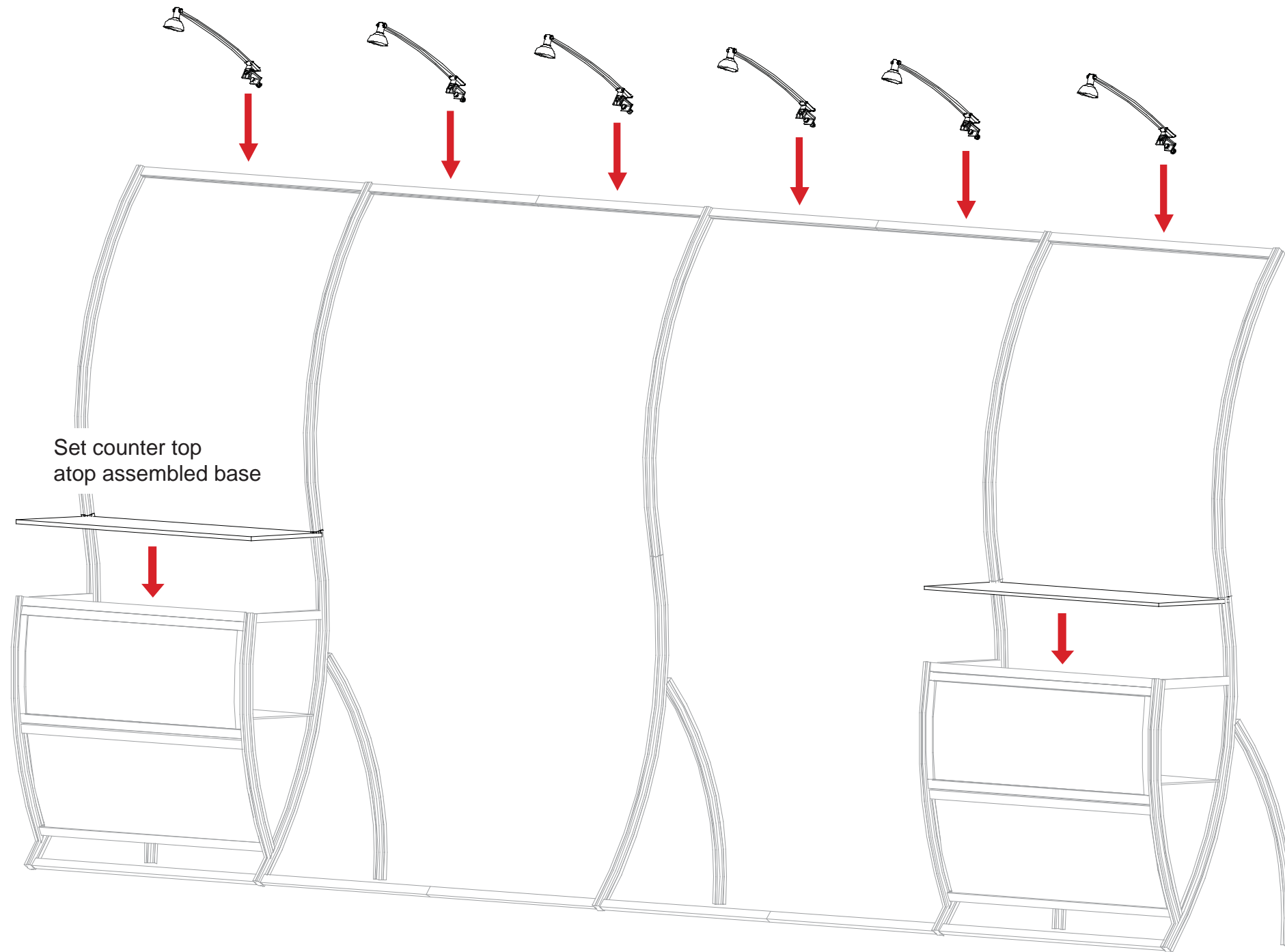

WHEN DISASSEMBLING TIGHTEN ALL KNOBS TO PREVENT LOSS DURING SHIPPING

866.652.2100

*Accessory Attachment*  
Attach Header support  
then Slide header into Groove

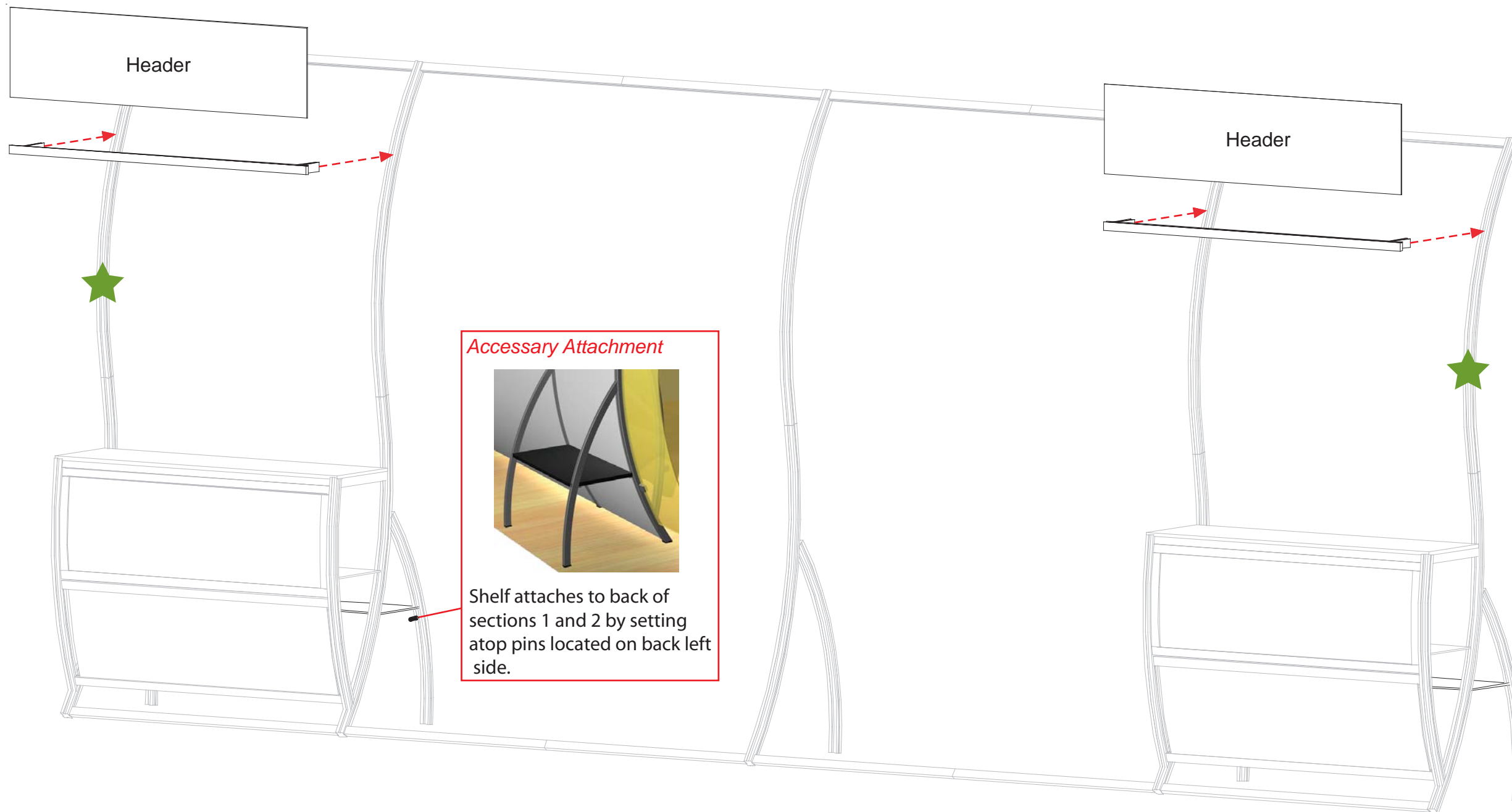

*Accessory Attachment*



Shelf attaches to back of sections 1 and 2 by setting atop pins located on back left side.

*Monitor Mount Attachment*

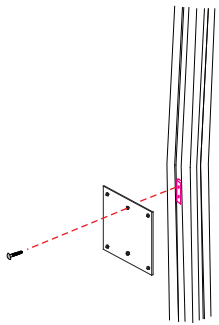

Attach back plate to connectors on vertical extrusion using screws. Then attach top plate and tighten setscrews to secure.

WHEN DISASSEMBLING TIGHTEN ALL KNOBS TO PREVENT LOSS DURING SHIPPING

Part Number	Description
A	Left Leg Assembly
B	Right Leg Assembly
C	Horizontal Extrusion
D	Horizontal Extrusion w/ Door Stopper

Step 1:

- A) Connect lower horizontal extrusion [C] between bottom of leg assemblies [A and B] as shown.
- B) Insert Laminated infill into grooves of leg assemblies [A and B].
- C) Attach extrusion door between leg assemblies [A and B] and atop laminated infill.
- D) Attach upper horizontal extrusion w/ door stopper [D] between leg assemblies [A and B], and set flush with top of legs [A and B].

**NOTE: Make sure the lock is flush with extrusion before tightening. If lock will not fully engage, gently rock lock and extrusion back and forth while turning knob until lock fully opens.**

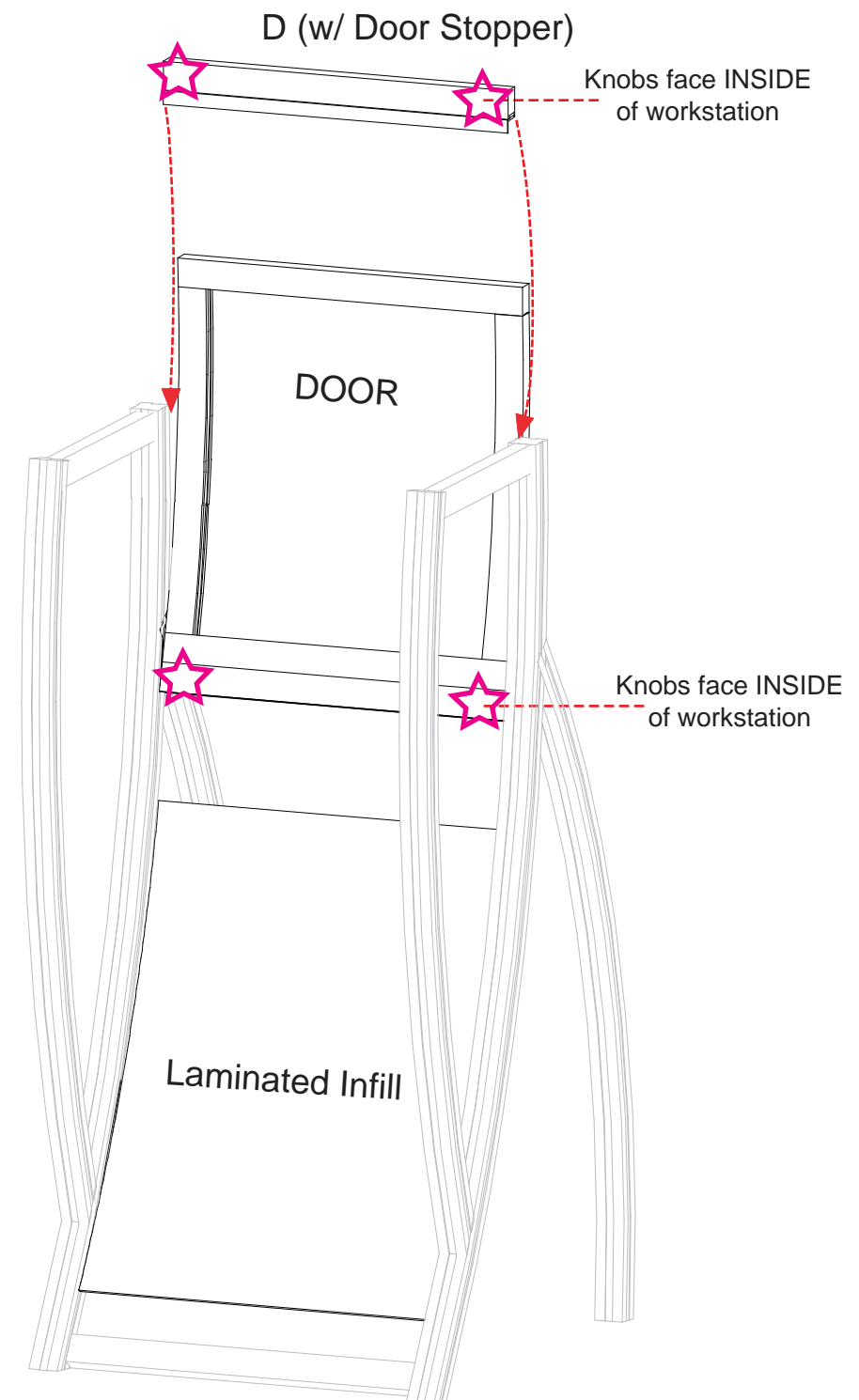
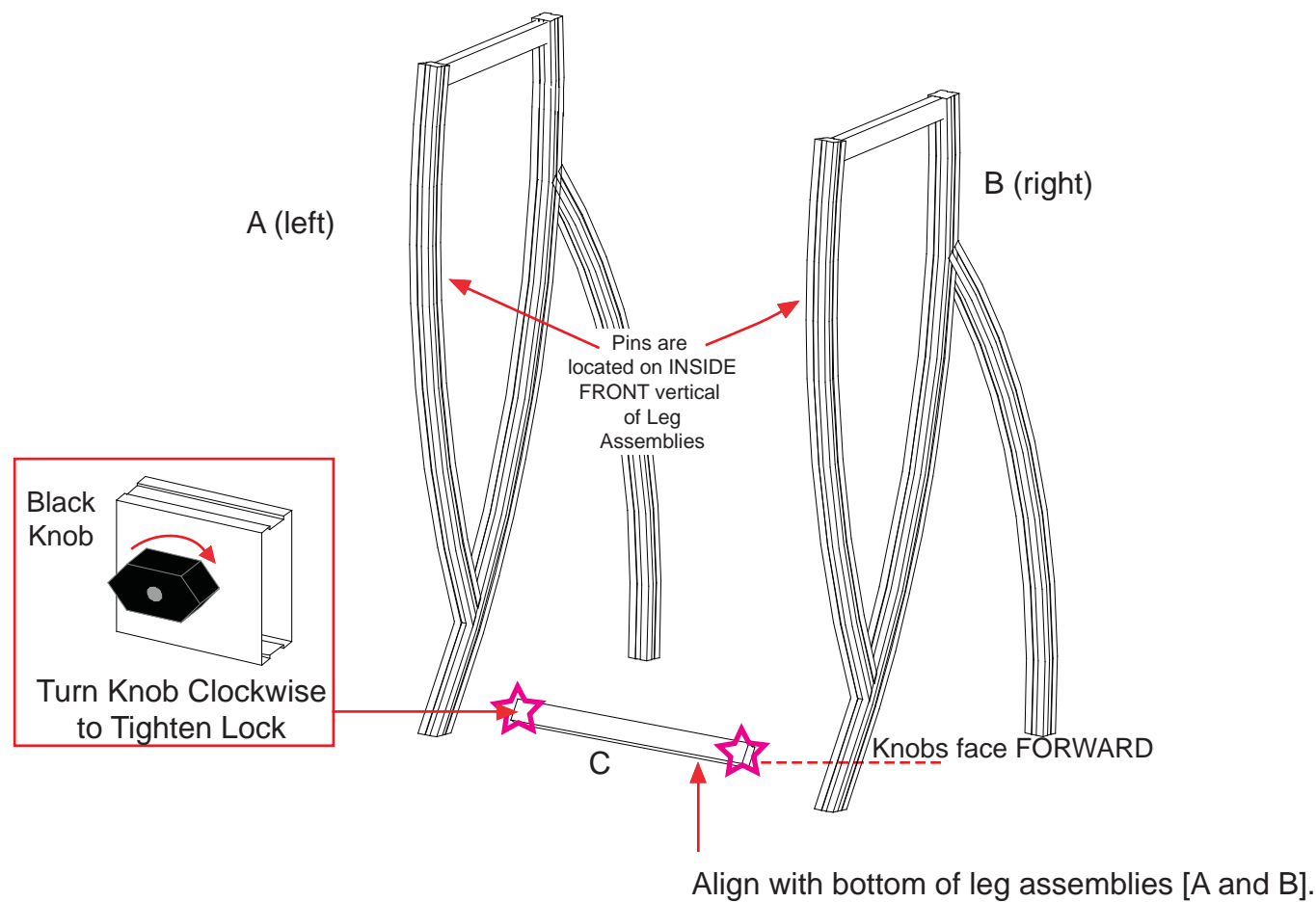

**WHEN DISASSEMBLING TIGHTEN ALL KNOBS TO PREVENT LOSS DURING SHIPPING**

Part Number	Description
E	Horizontal Extrusion
F	Horizontal Extrusion

Step 2:

- A) Attach horizontal extrusion [E] between vertical leg assemblies [A and B] as shown below.
- B) Insert Laminated infill into grooves of vertical leg assemblies [A and B].
- C) Attach upper horizontal extrusion [F] between vertical leg assemblies [A and B] atop infill.
- D) Place internal shelf into assembled pedestal atop pins..
- E) Set Counter atop assembled pedestal and secure with Velcro straps attached to underside of top.

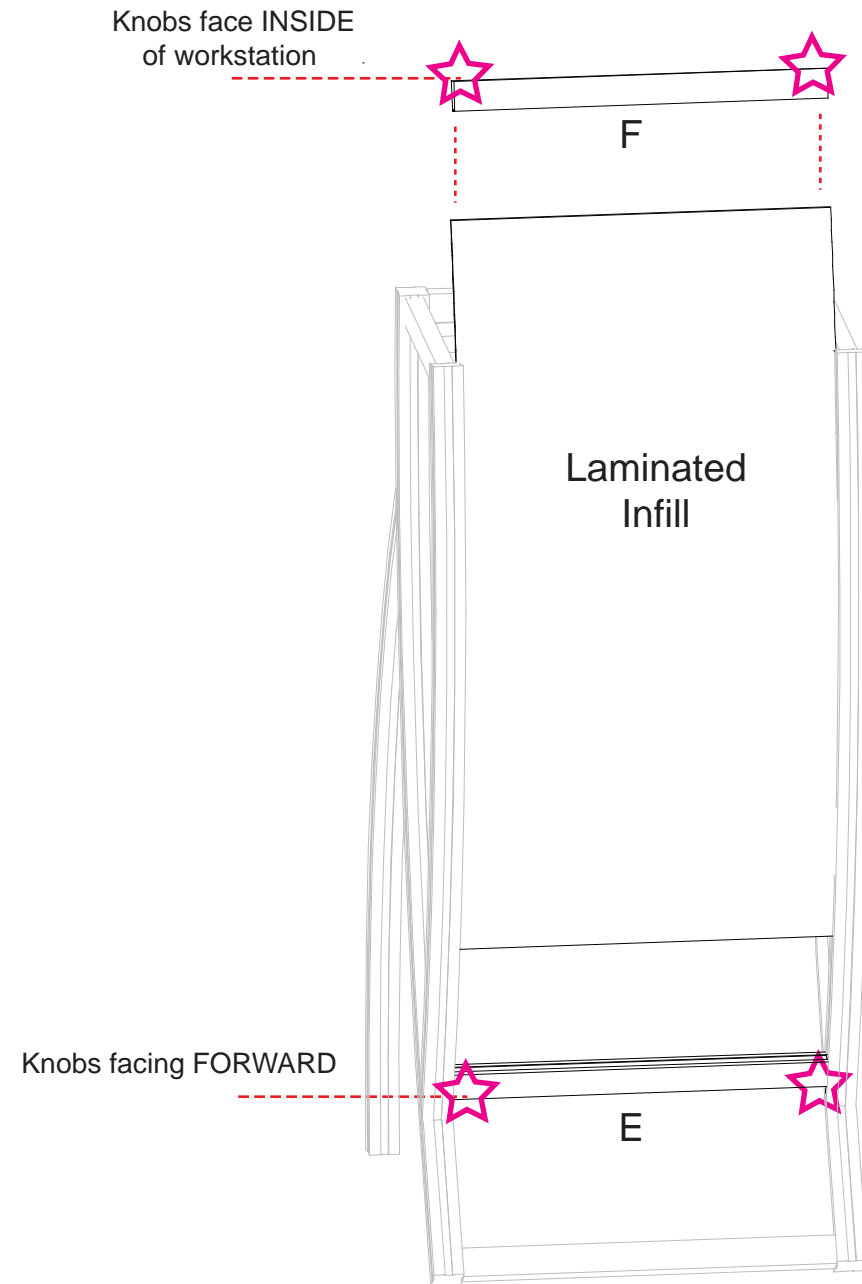

Place internal shelf into workstation then place counter atop assembled workstation.

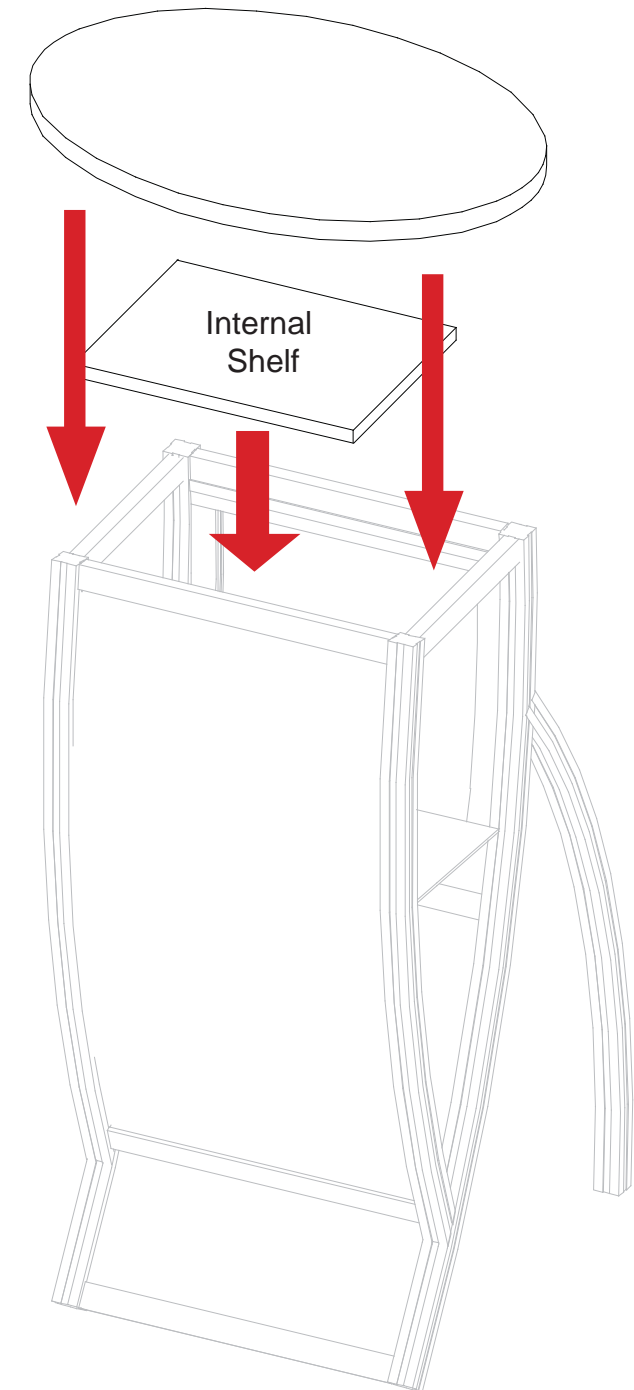

WHEN DISASSEMBLING TIGHTEN ALL KNOBS TO PREVENT LOSS DURING SHIPPING

866.652.2100

Part Number	Description
G	Monitor Mount Extrusion

- Step 3:
- A) Slide Connection Bar into lower leg assembly. Slide upper vertical over bar and secure both.
  - B) Attach Monitor Mount to vertical as shown in Detail below.
  - C) Attach Graphic to back of vertical extrusion as shown.

**Monitor Mount Attachment**

NOTE: Monitor mount should be installed while laying down on floor

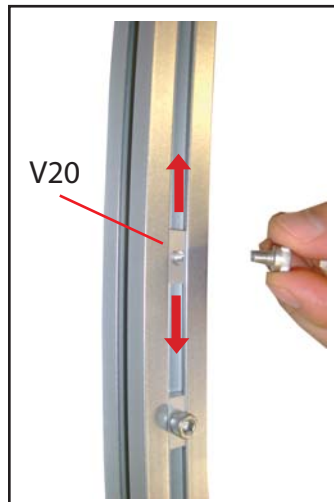

Adjust V20 connector to desired location. Then remove screws.

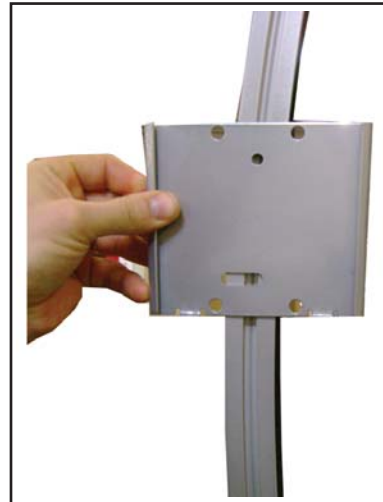

Place mount plate in front of V20 connectors. Then secure with screws.

**Hex Key Tool**



(if necessary)

**Flathead Screwdriver**

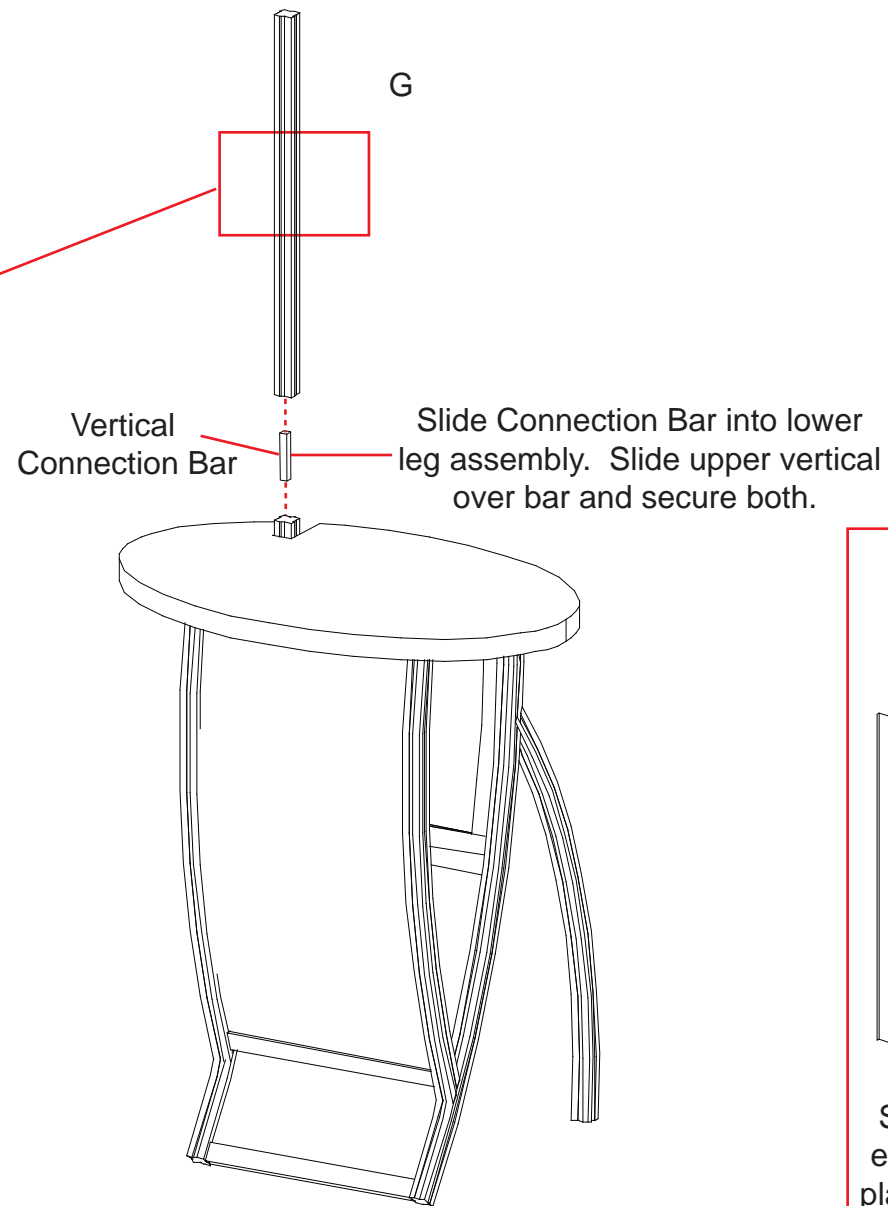

**Graphic Attachment**

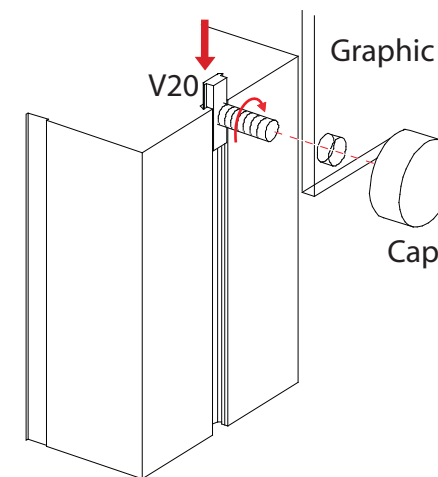

Slide connector into groove of extrusion and twist to secure in place. Secure graphic with caps.

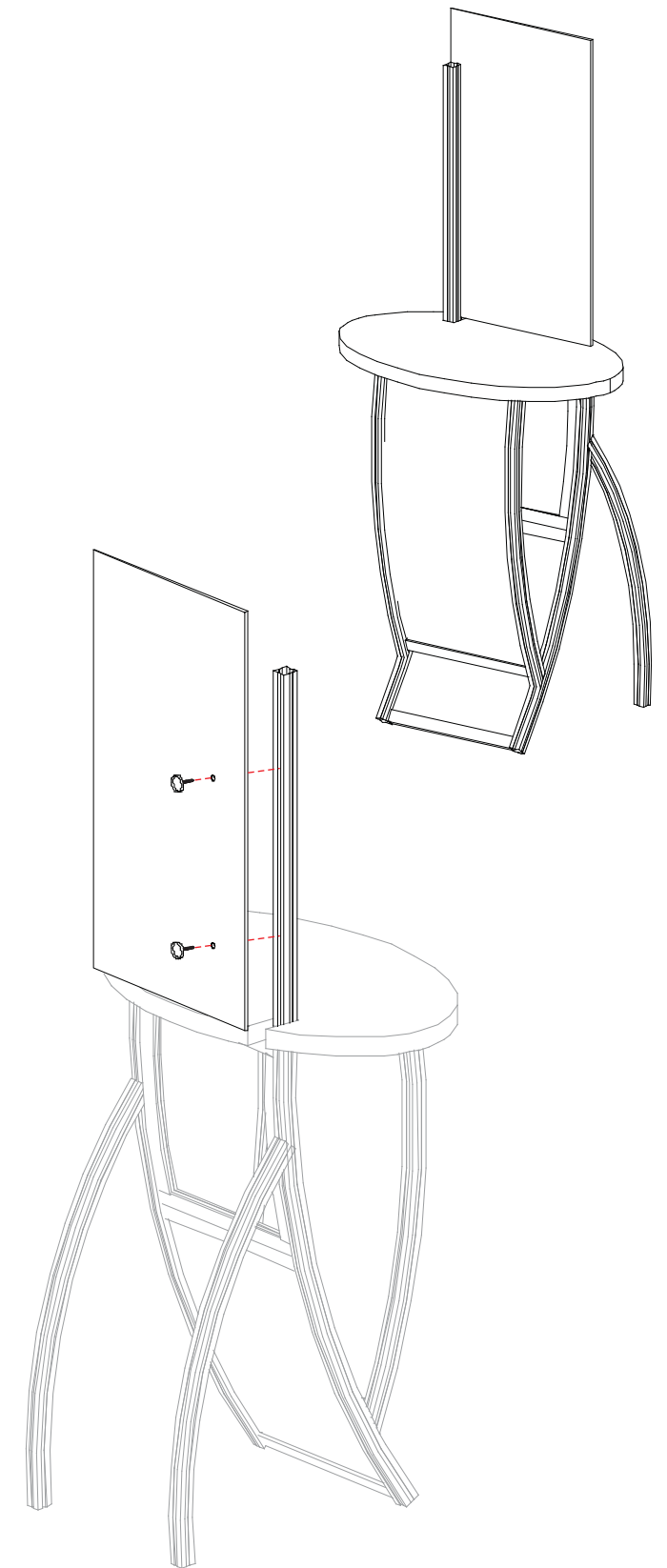

**WHEN DISASSEMBLING TIGHTEN ALL KNOBS TO PREVENT LOSS DURING SHIPPING**

Part Number	Description
AA	Left Leg Assembly
BB	Right Leg Assembly
CC	Horizontal Extrusion
DD	Horizontal Extrusion w/ Door Stopper

Step 1:

- A) Connect lower horizontal extrusion [CC] between bottom of leg assemblies [AA and BB] as shown.
- B) Insert Laminated infill into grooves of leg assemblies [AA and BB].
- C) Attach extrusion door between leg assemblies [AA and BB] and atop laminated infill.
- D) Attach upper horizontal extrusion w/ door stopper [DD] between leg assemblies [AA and BB], and set flush with top of legs [AA and BB].

**NOTE: Make sure the lock is flush with extrusion before tightening. If lock will not fully engage, gently rock lock and extrusion back and forth while turning knob until lock fully opens.**

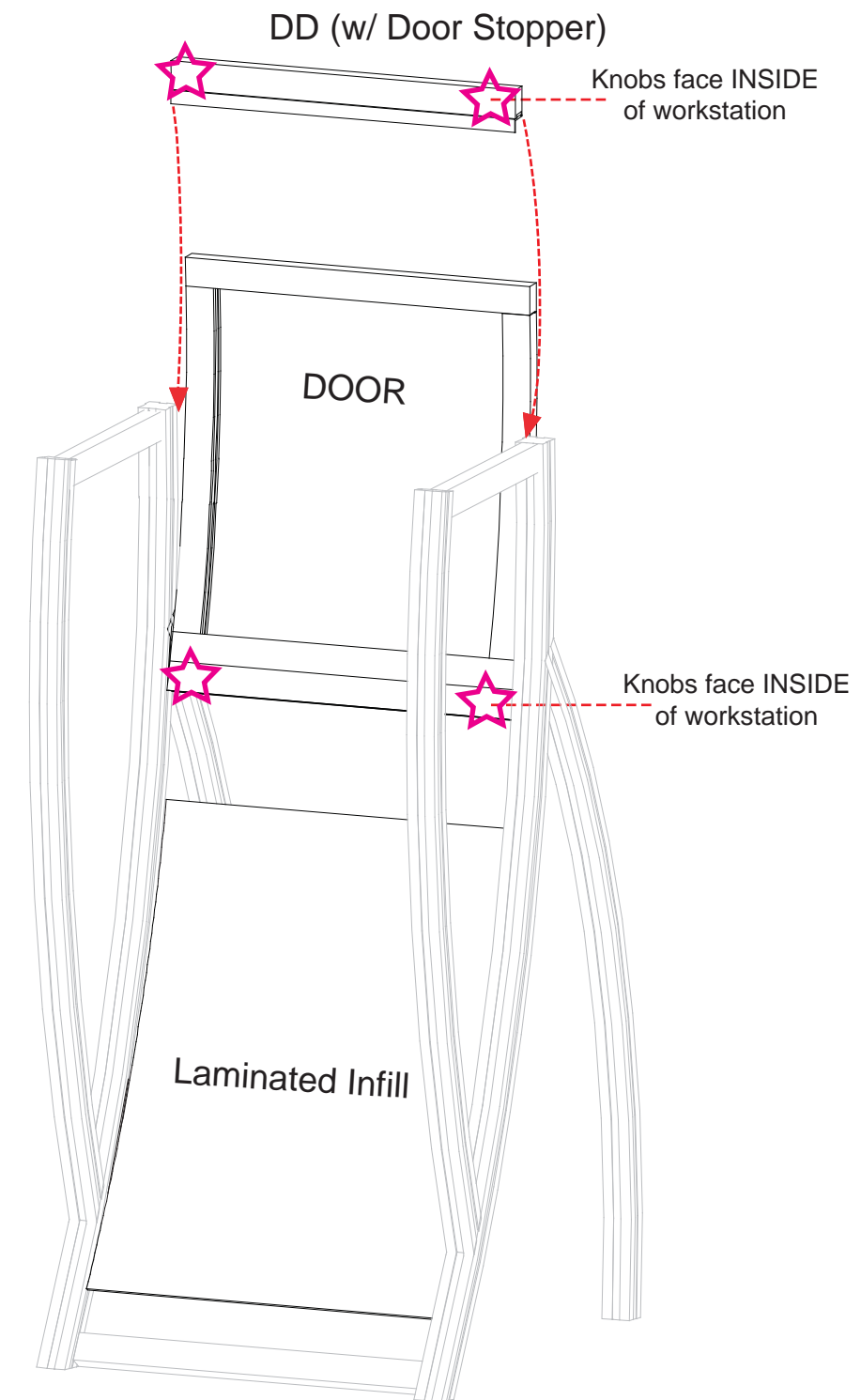
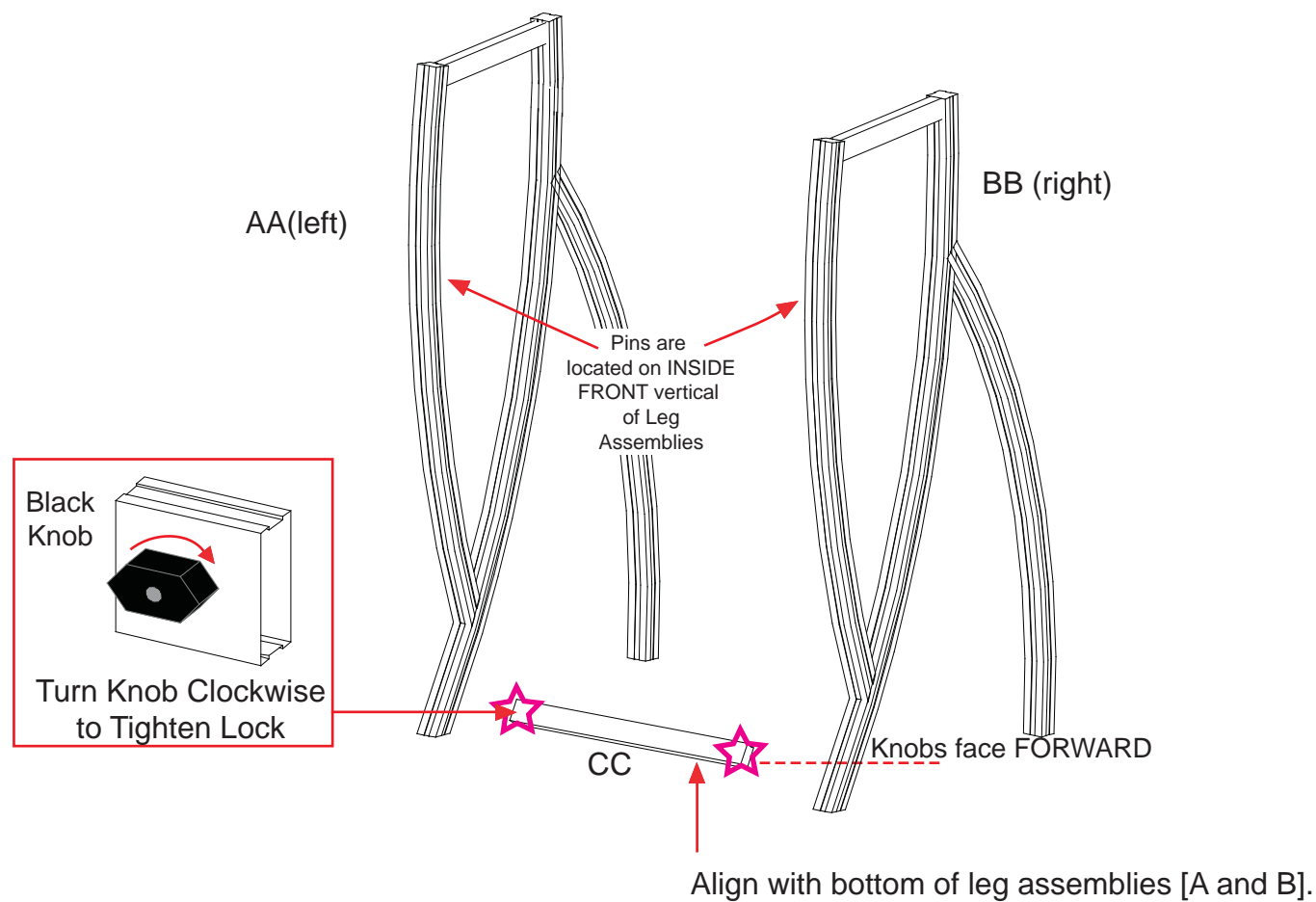

**WHEN DISASSEMBLING TIGHTEN ALL KNOBS TO PREVENT LOSS DURING SHIPPING**

866.652.2100

Part Number	Description
EE	Horizontal Extrusion
FF	Horizontal Extrusion

- Step 2:
- A) Attach horizontal extrusion [EE] between vertical leg assemblies [AA and BB] as shown below.
  - B) Insert Laminated infill into grooves of vertical leg assemblies [AA and BB].
  - C) Attach upper horizontal extrusion [FF] between vertical leg assemblies [AA and BB] atop infill.
  - D) Place internal shelf into assembled pedestal atop pins..
  - E) Set Counter atop assembled pedestal and secure with Velcro straps attached to underside of top.

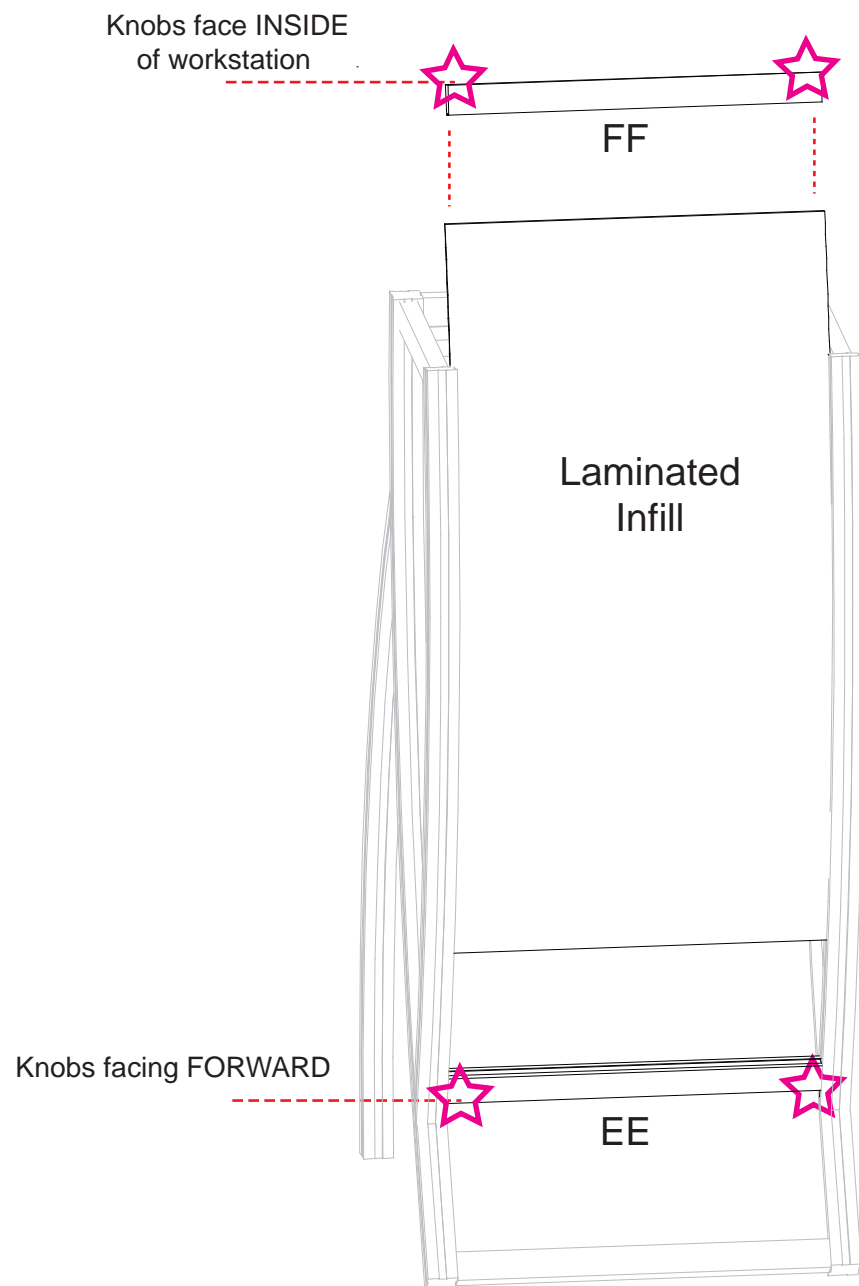

Place internal shelf into workstation then place counter atop assembled workstation.

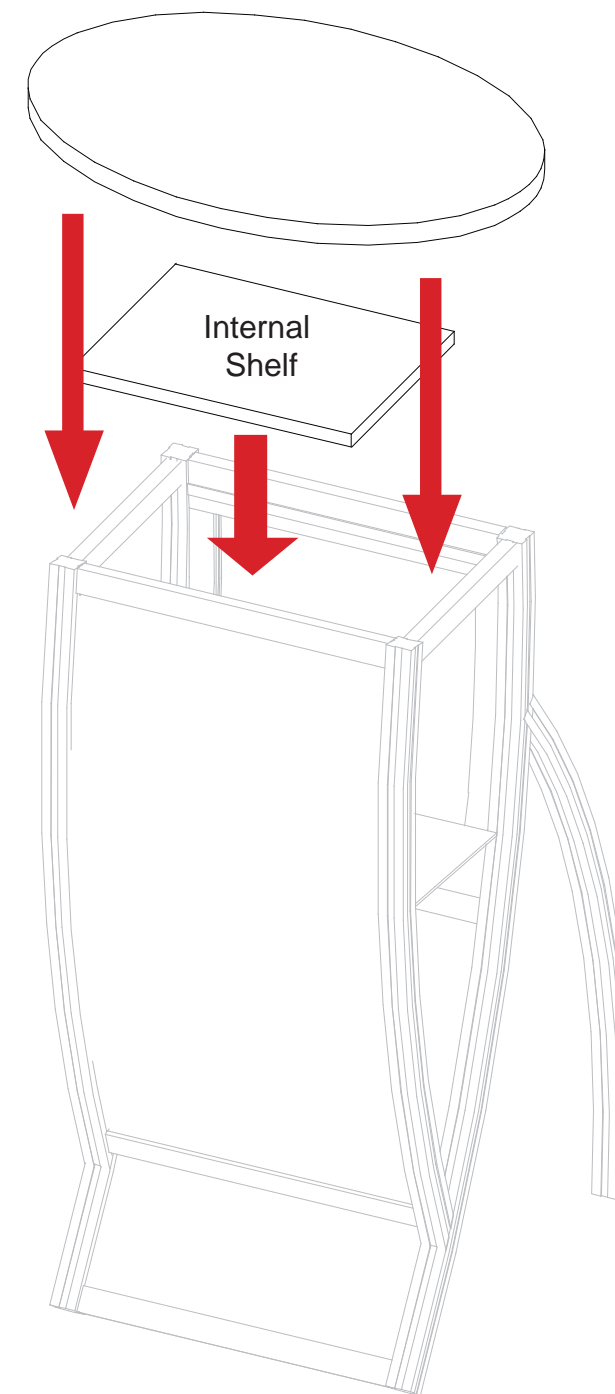

**WHEN DISASSEMBLING TIGHTEN ALL KNOBS TO PREVENT LOSS DURING SHIPPING**

Case #1 - Backwall Components

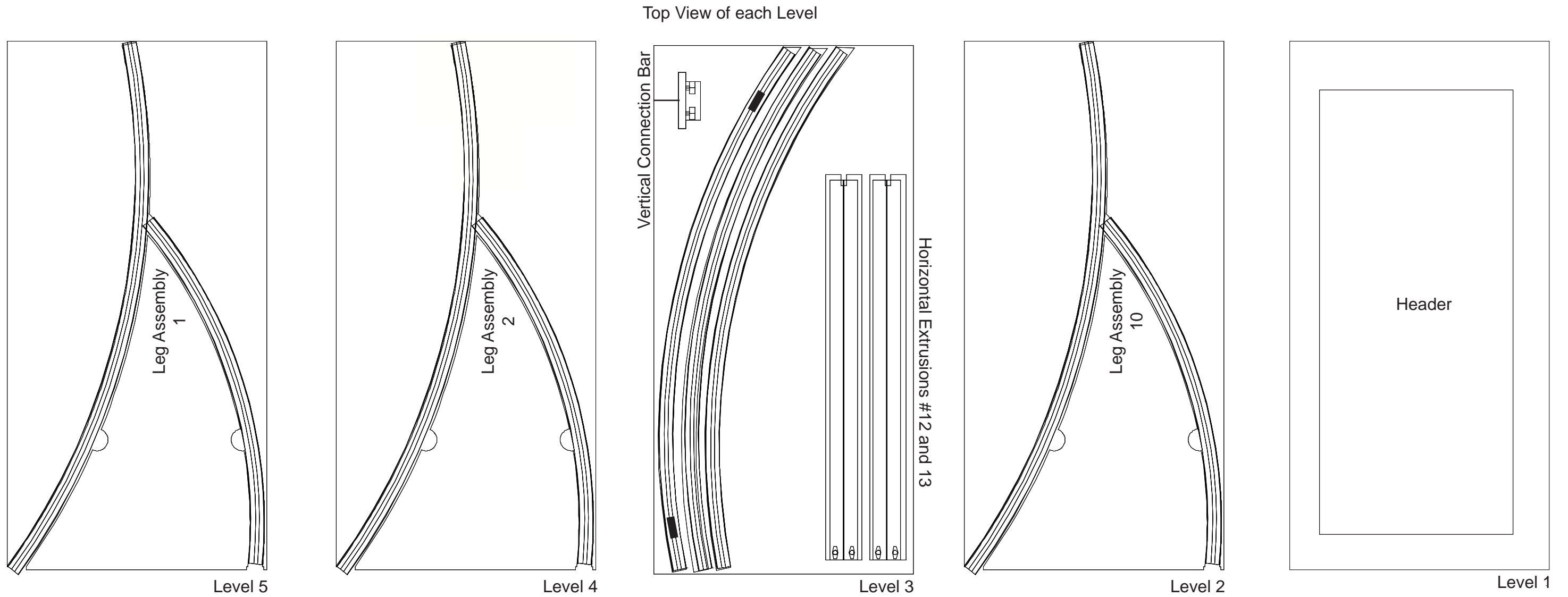

- Additional Items:
- Setup Hardware
  - Graphics
  - Lights

WHEN DISASSEMBLING TIGHTEN ALL KNOBS TO PREVENT LOSS DURING SHIPPING

Case #2 - Backwall Components

Top View of each Level

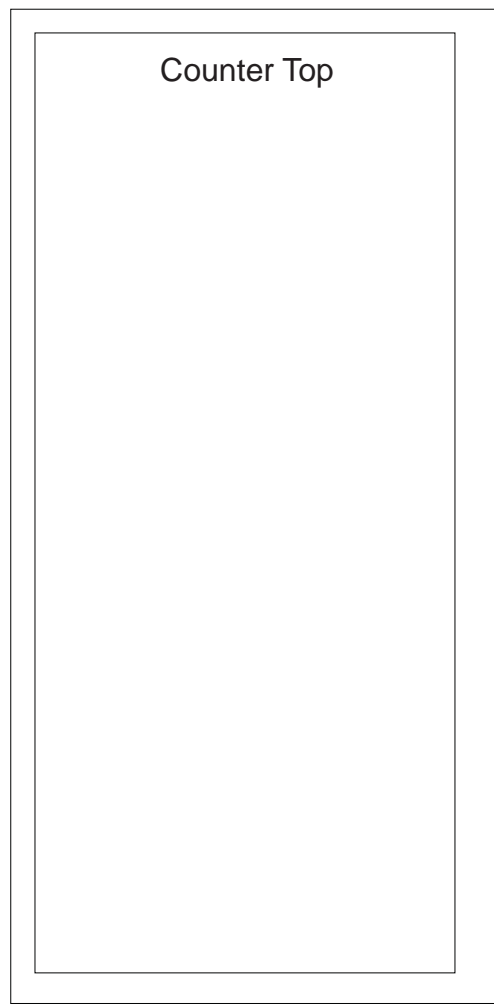

Level 5

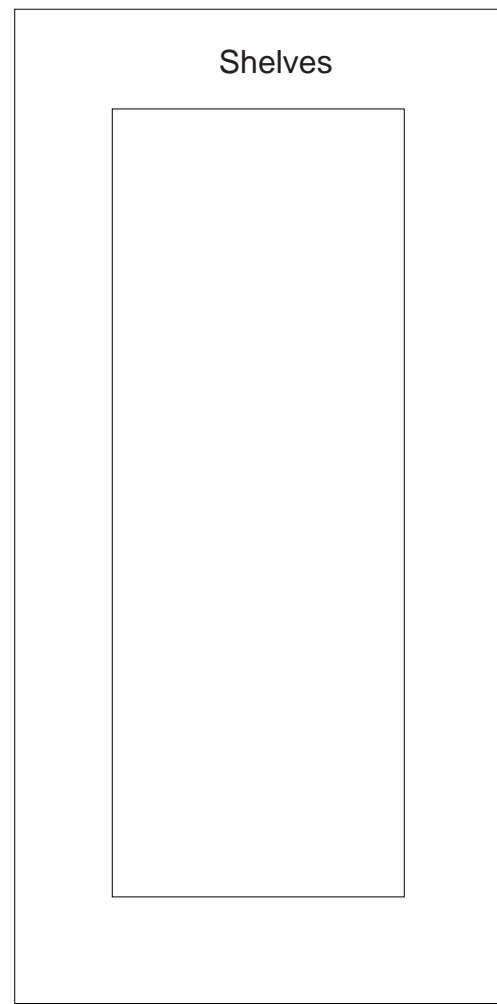

Level 4

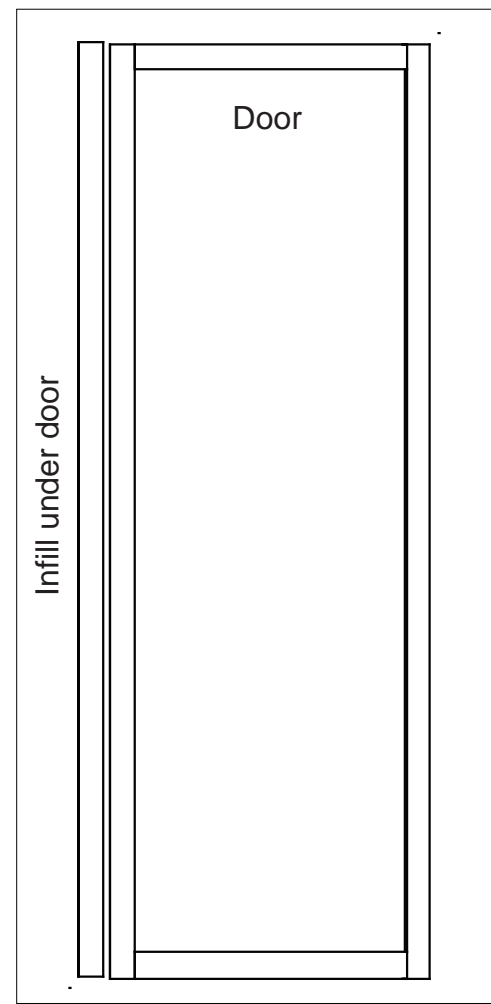

Level 3

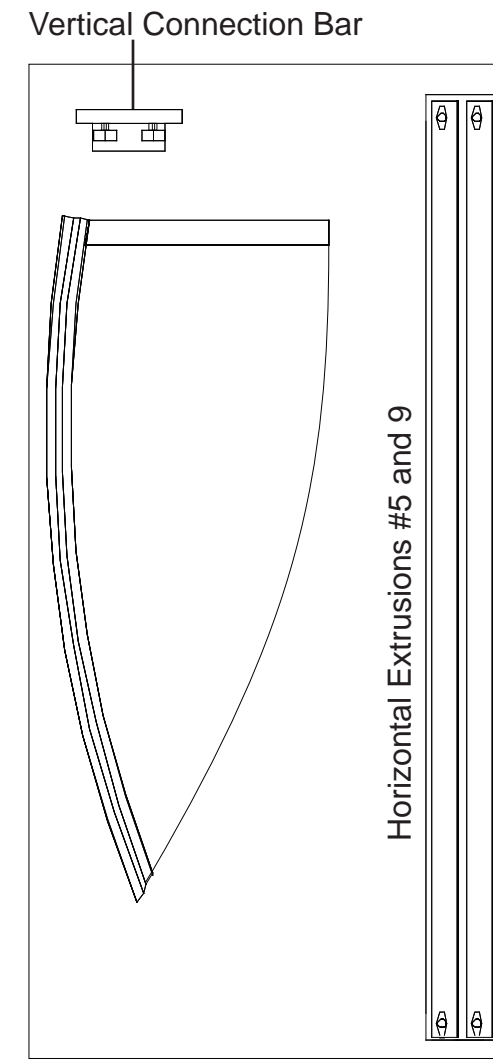

Level 2

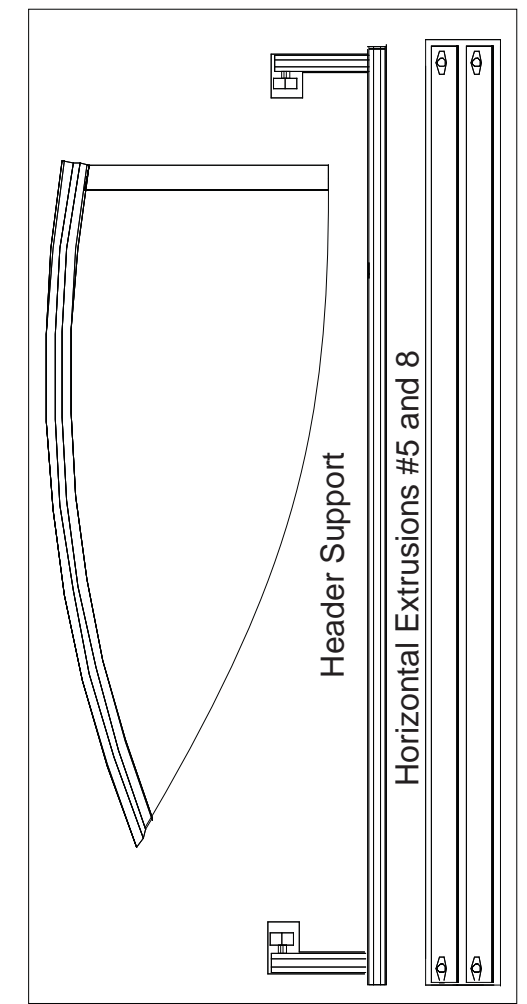

Level 1

WHEN DISASSEMBLING TIGHTEN ALL KNOBS TO PREVENT LOSS DURING SHIPPING

Case #3 - Backwall Components

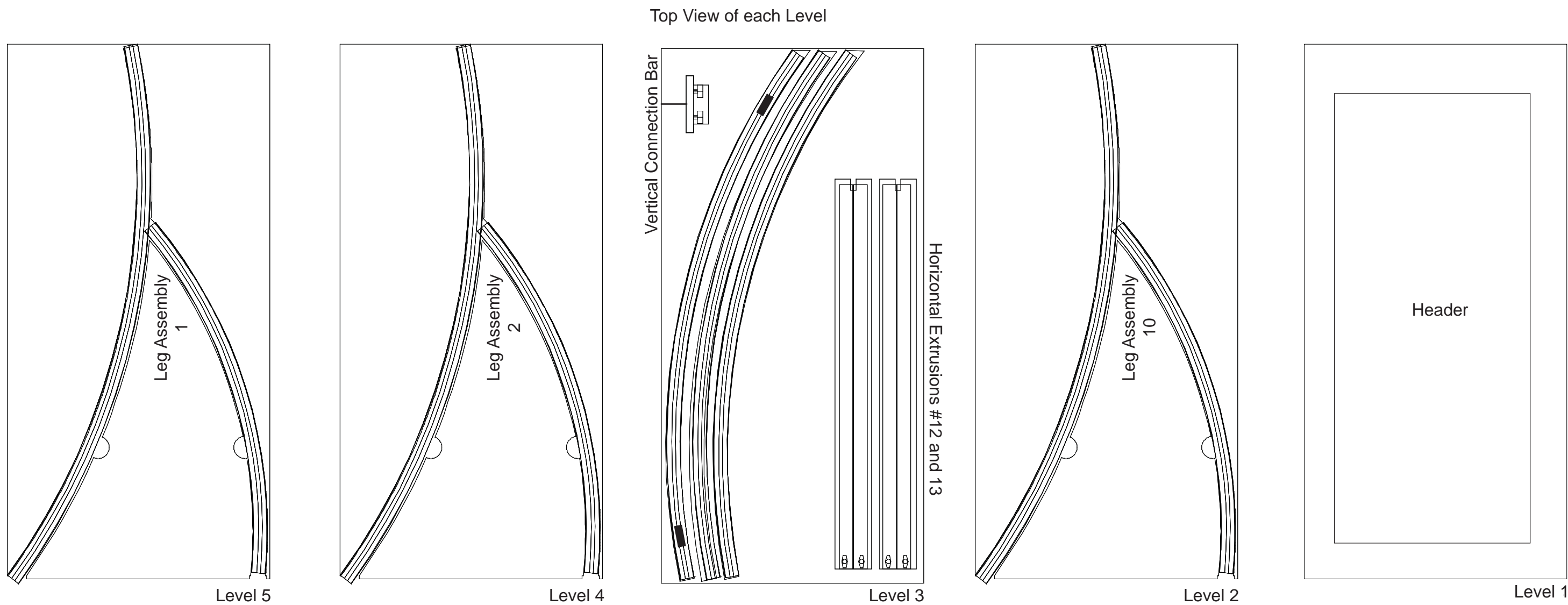

- Additional Items:
- Setup Hardware
  - Graphics
  - Lights

WHEN DISASSEMBLING TIGHTEN ALL KNOBS TO PREVENT LOSS DURING SHIPPING

Case #4 - Backwall Components

Top View of each Level

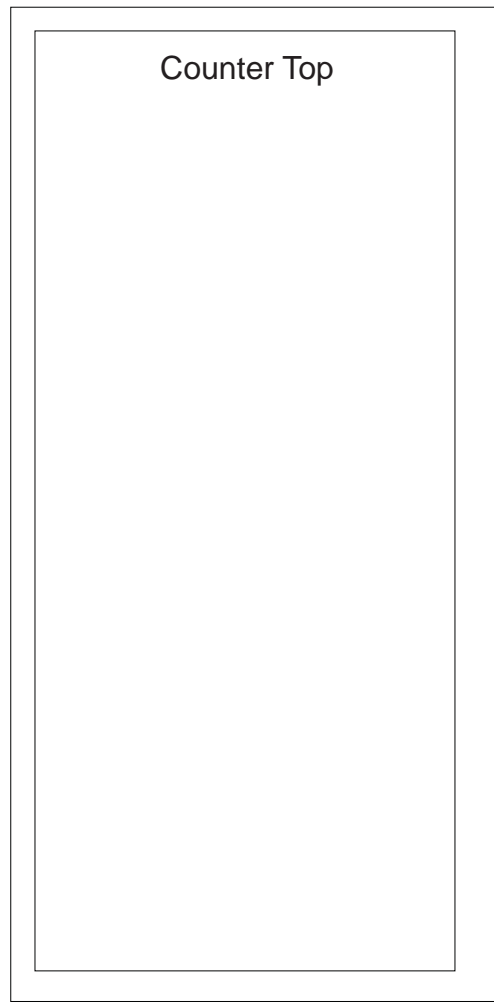

Level 5

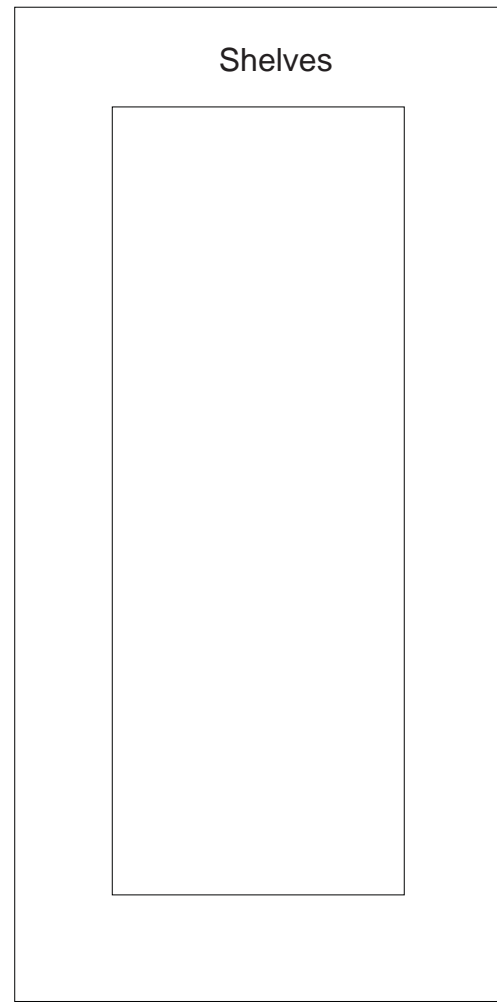

Level 4

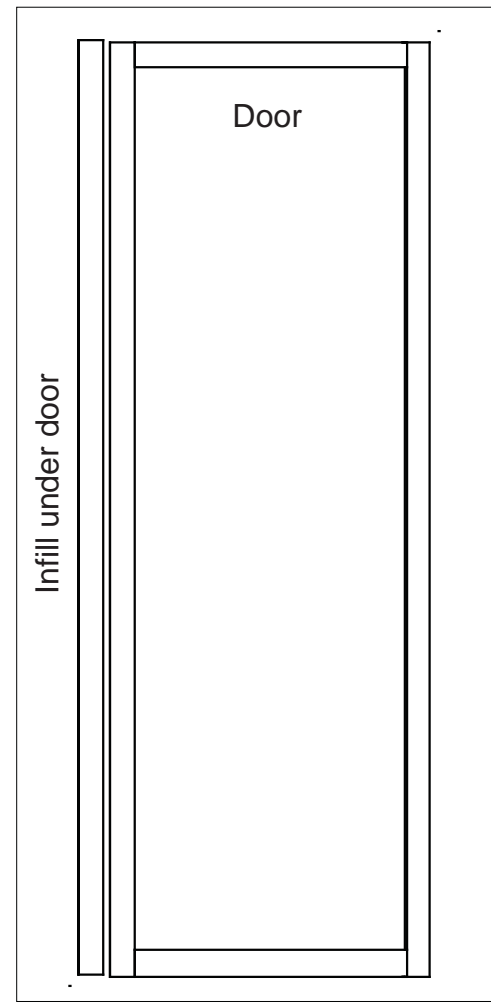

Level 3

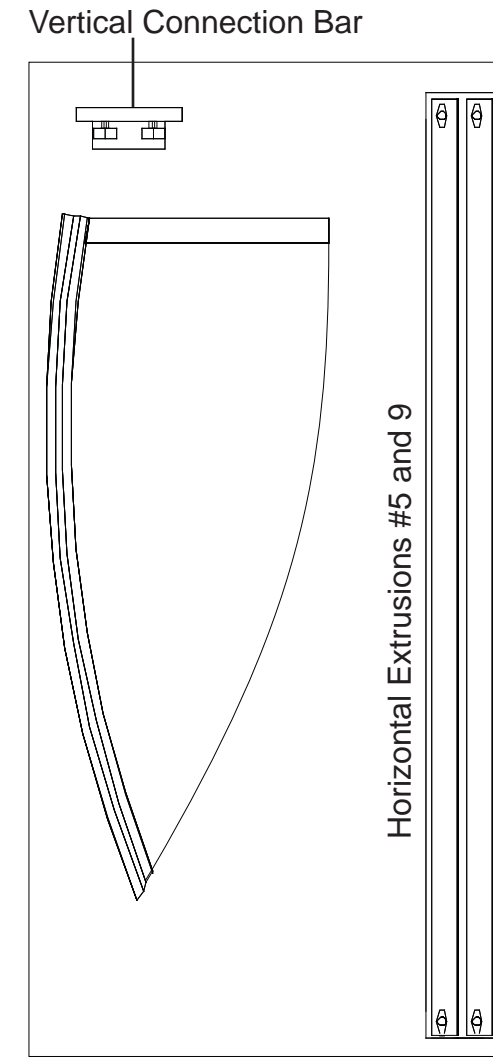

Level 2

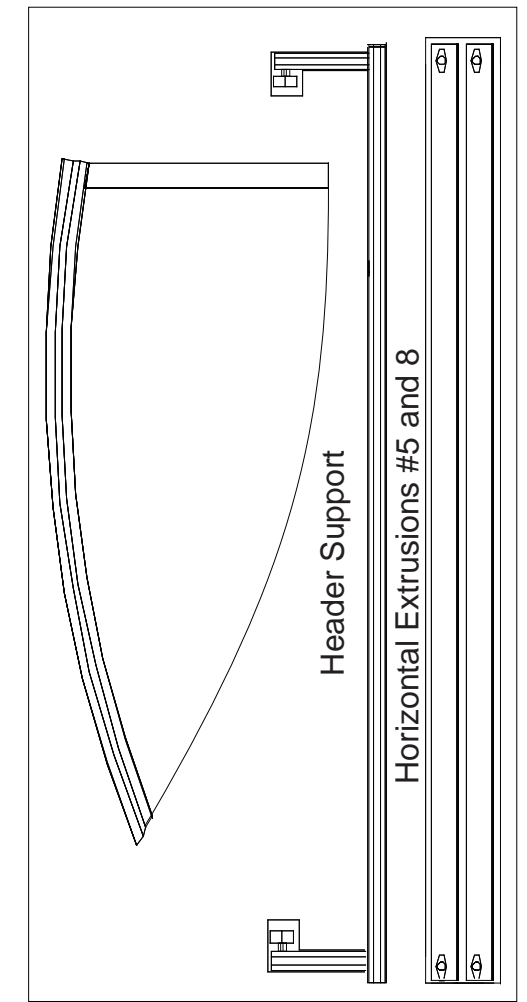

Level 1

WHEN DISASSEMBLING TIGHTEN ALL KNOBS TO PREVENT LOSS DURING SHIPPING

Case #5 - Pedestal Components

Top View of each Level

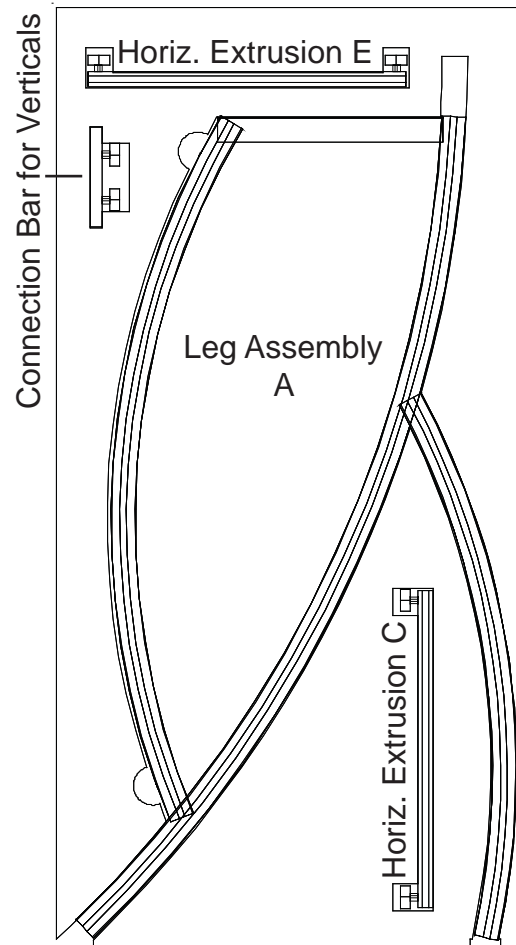

Level 5

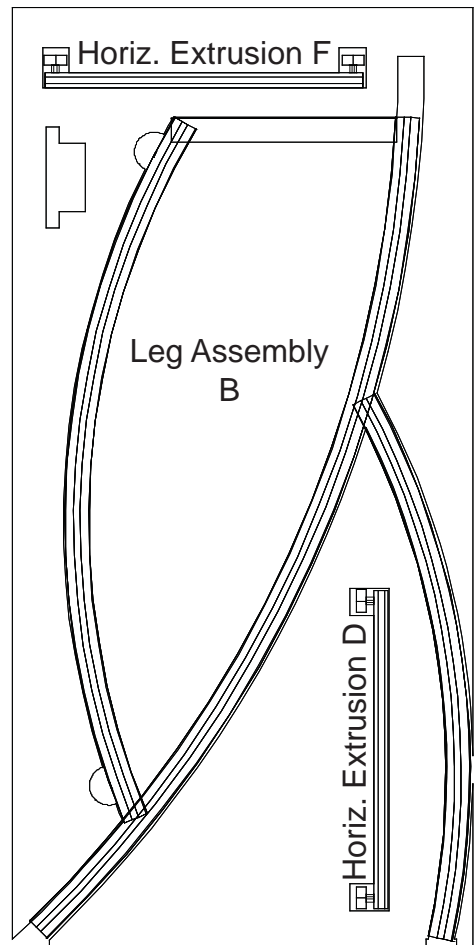

Level 4

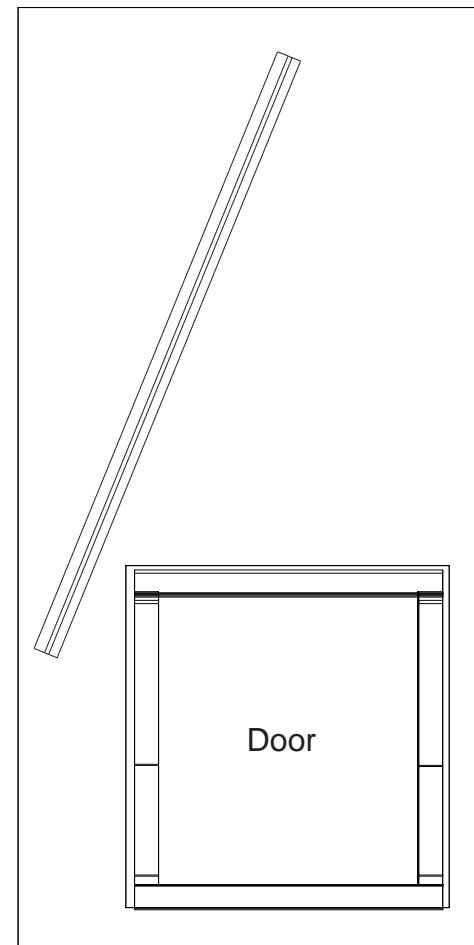

Level 3

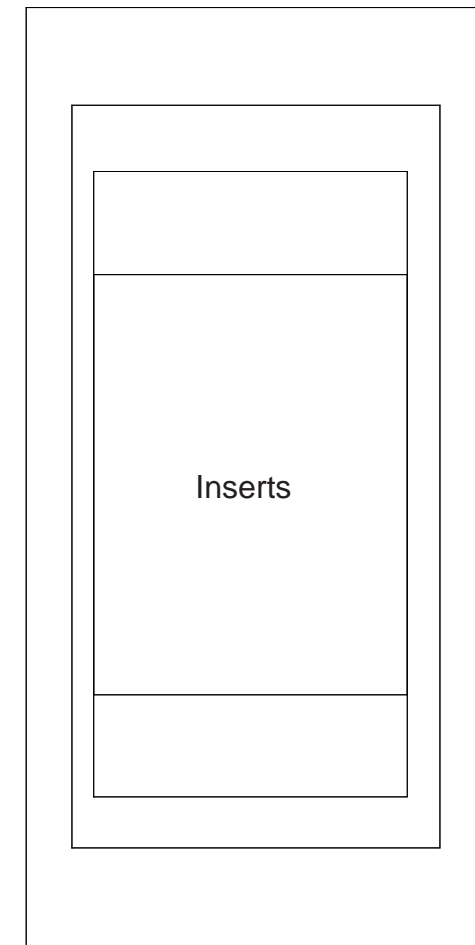

Level 2

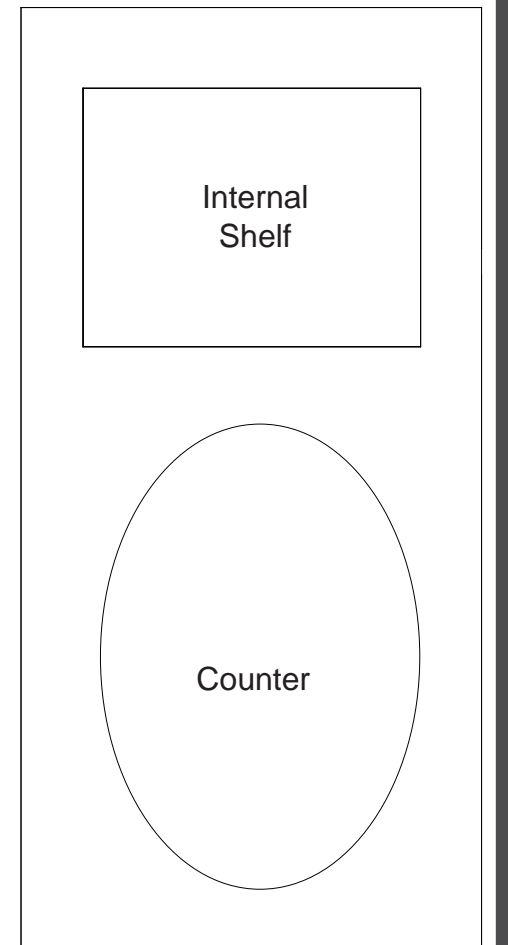

Level 1

WHEN DISASSEMBLING TIGHTEN ALL KNOBS TO PREVENT LOSS DURING SHIPPING

Case #6 - Backwall Components

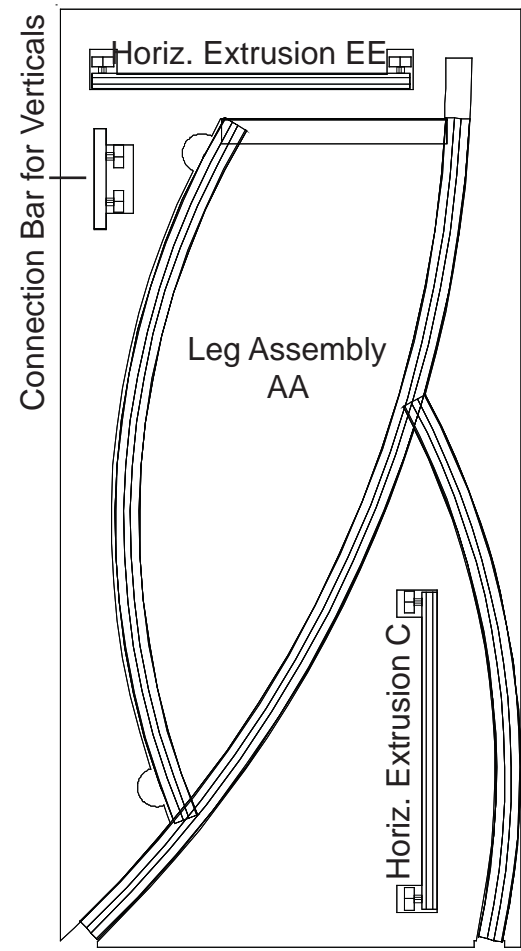

Level 5

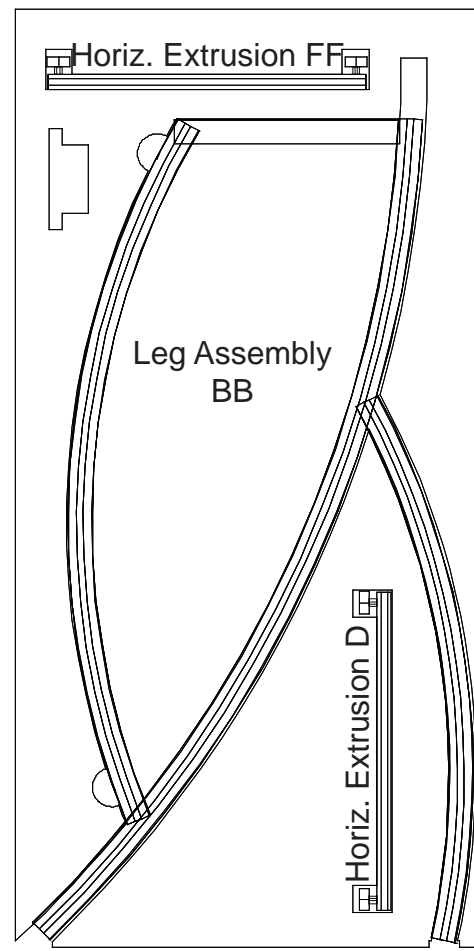

Level 4

Top View of each Level

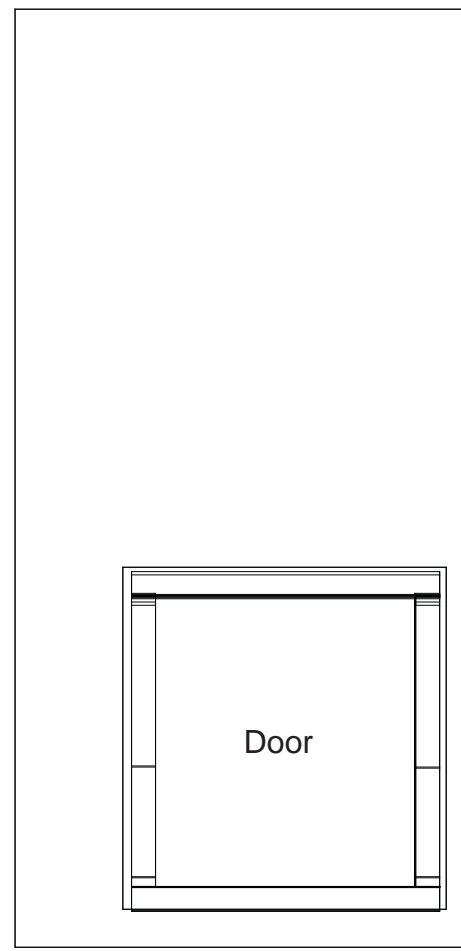

Level 3

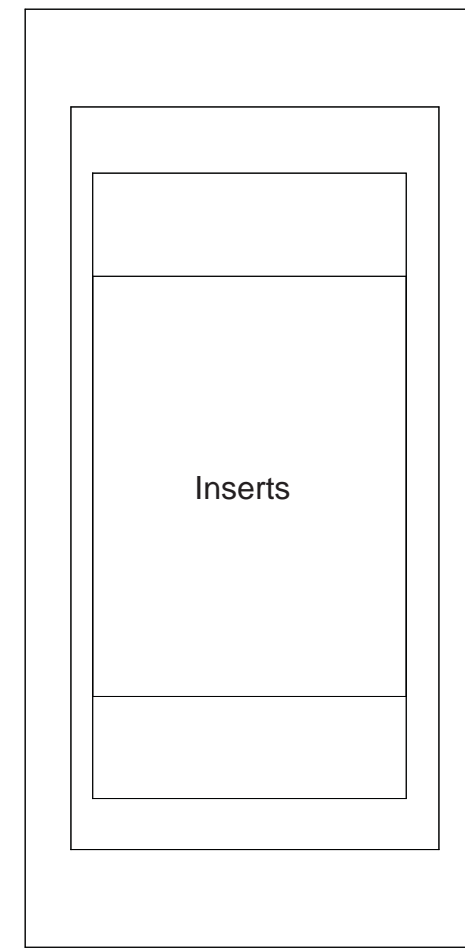

Level 2

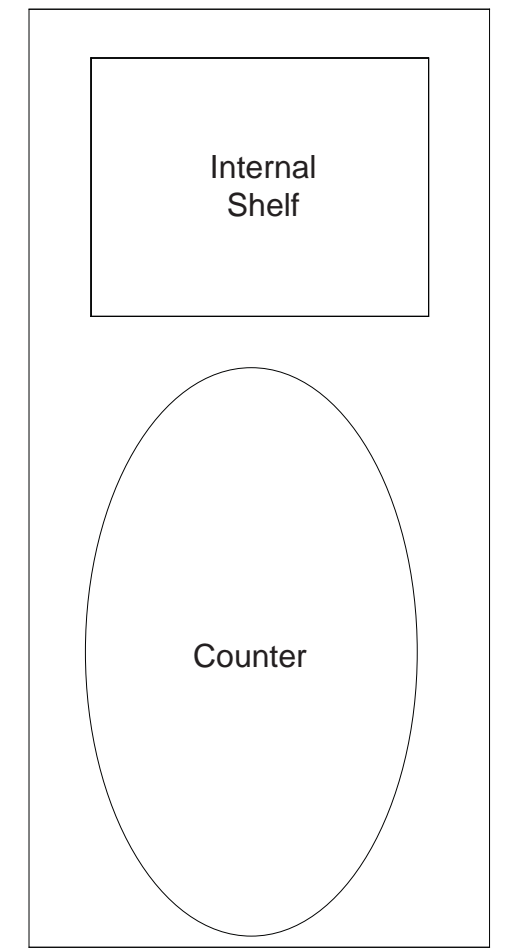

Level 1

WHEN DISASSEMBLING TIGHTEN ALL KNOBS TO PREVENT LOSS DURING SHIPPING

Case #7 - Pedestal Components

Top View of each Level

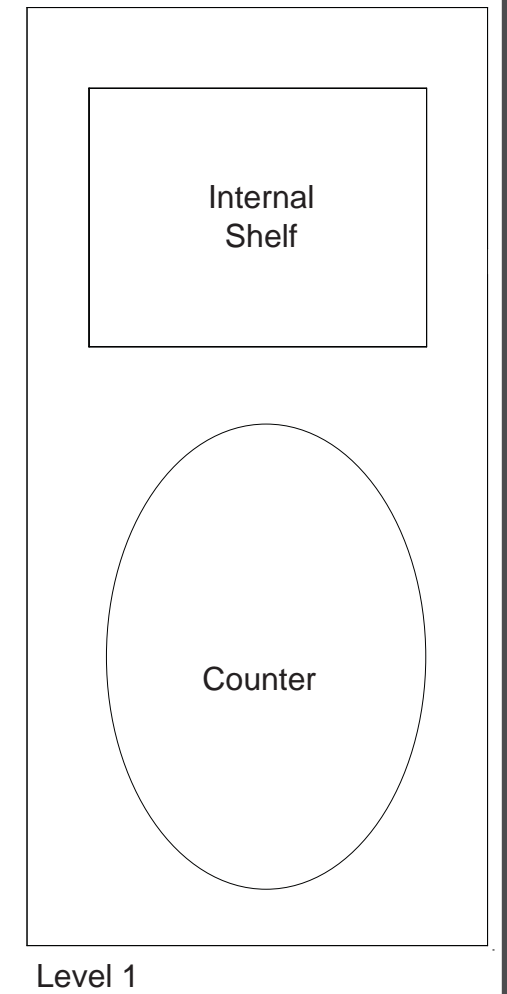
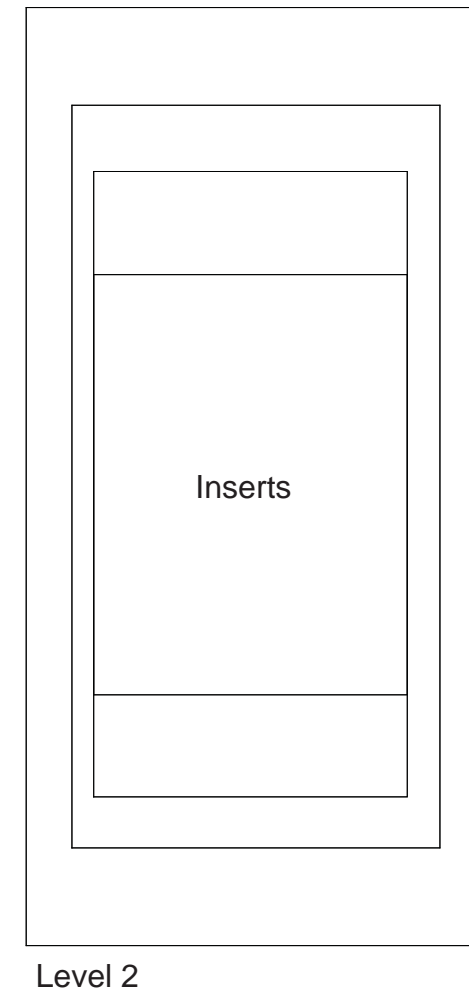
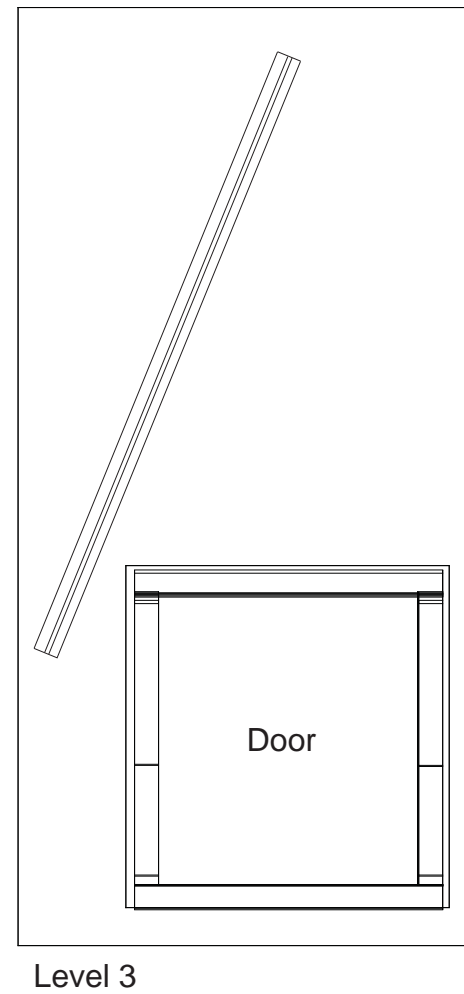
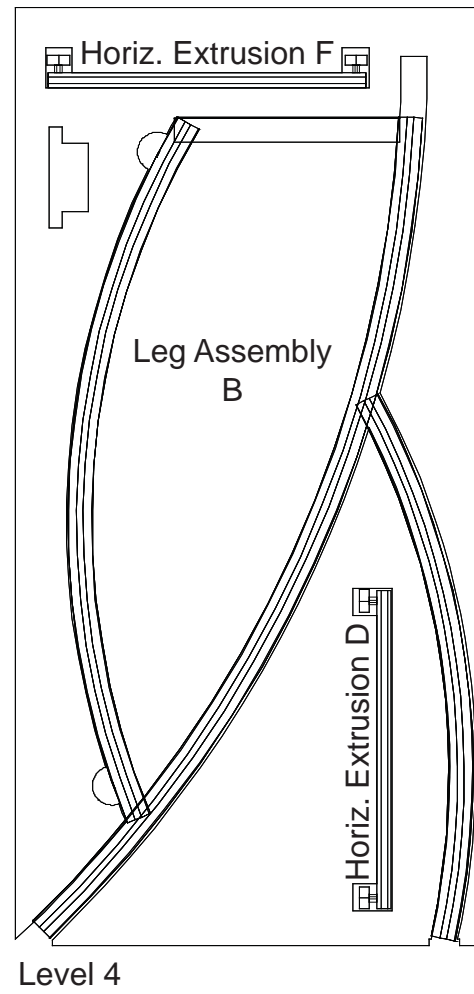
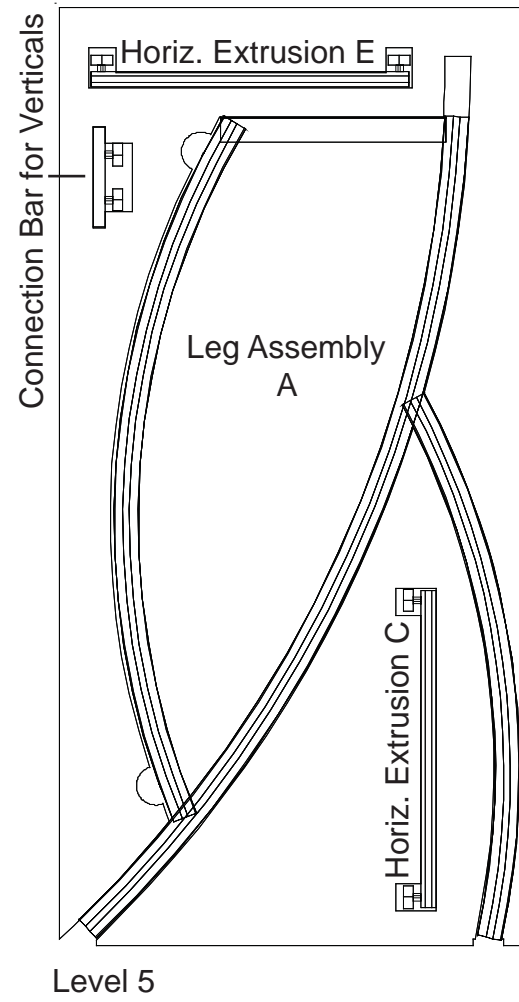

WHEN DISASSEMBLING TIGHTEN ALL KNOBS TO PREVENT LOSS DURING SHIPPING