

WHEN DISASSEMBLING ALUMINUM EXTRUSION, TIGHTEN ALL SETSCREWS AND LOCKS TO PREVENT LOSS DURING SHIPPING

visionary™ IDESIGNS

Using Your Setup Instructions

The Visionary Designs Setup Instructions are created specifically for your configuration. They are laid out sequentially, including an exploded view of the entire display, and then a logical series of detailed steps to assemble the main structure and components. We encourage you to study the instructions **before** attempting to assemble your exhibit.

Each page reminds you to tighten the setscrews after disassembling your exhibit to prevent loss of the locks and setscrews (see below in RED). This is **VERY IMPORTANT**.

Cleaning and Packing Your Display

- 1) Use care when cleaning aluminum extrusion or acrylic inserts. Use only non-abrasive cleaners.
- 2) When cleaning laminate inserts or countertops, use mild cleansers and a soft material such as cotton.
- 3) Keep all display components away from extreme heat and long exposure to sunlight to avoid warping and fading.
- 4) Retain all packing material. It will make re-packing much easier and will reduce the likelihood of shipping damage.



The Tool

Most Visionary Designs exhibits can be assembled with the supplied Hex Key Tool. Occasionally, a flat head screwdriver may be required.



Detail A

Typical Connection



Typical Connection (cont'd)

Most horizontal extrusion connections have a patented expandable lock. This lock inserts into the groove of an opposing extrusion. Tightening the lock with the Hex Key Tool expands the lock and creates a strong positive connection.



Detail B

Numbered Label

Each extrusion contains a numbered label which corresponds with setup instructions. The label is located within a groove of the extrusion (when possible). With Visionary Designs the labels contain Black numbers unless otherwise specified.



Detail C

Horizontal Inline Connection (remove only one setscrew)

Remove only (1) setscrew when disassembling. Replace setscrew in extrusion after assembling it. Before packing, replace setscrew in extrusion to avoid losing it.

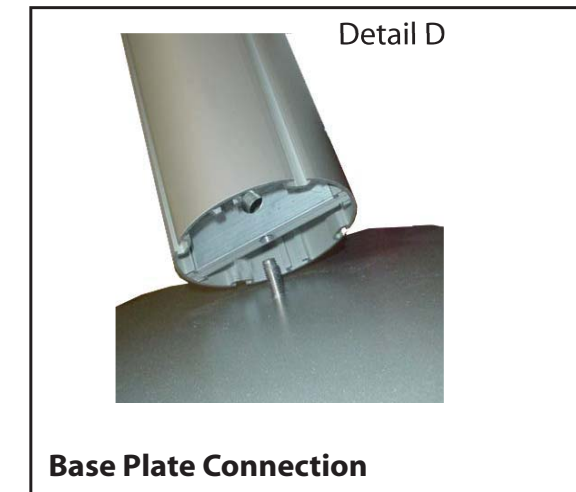

Detail D

Base Plate Connection

Attach base plate to round or square vertical extrusion using the bolt provided. Be careful not to strip the threads.



Detail E

Vertical Connection
(remove only two setscrews)

When vertical extrusions are packed in portable cases rather than crates or tubs, they must be broken down into smaller sections which then require assembly.

Remove only (2) setscrews when disassembling. Replace setscrews in extrusion after assembling it. Before packing, replace setscrews in extrusion to avoid losing them.

WHEN DISASSEMBLING ALUMINUM EXTRUSION, TIGHTEN ALL SETSCREWS AND LOCKS TO PREVENT LOSS DURING SHIPPING

Part Number	Qty	Description
1	2	Base Plate
2	1	47" h Lower Vertical Extrusion
3	1	47" h Upper Vertical Extrusion
4	1	48.115" Lower Curved Extrusion
5	1	48.115" Upper Curved Extrusion
6a/6b	1/1	52.476" Horizontal Curved Extrusion
7a/7b	1/1	52.476" Horizontal Curved Extrusion

Steps:

- 1) Attach vertical extrusions to base plates [2 to 1 and 4 to 1].
- 2) Connect vertical pieces together [2 to 3 and 4 to 5].
- 3) Connect curved extrusions together [6a to 6b and 7a to 7b].
- 4) Attach horizontal assemblies [6a/6b and 7a/7b] between vertical assemblies [2/3 and 4/5] as shown.

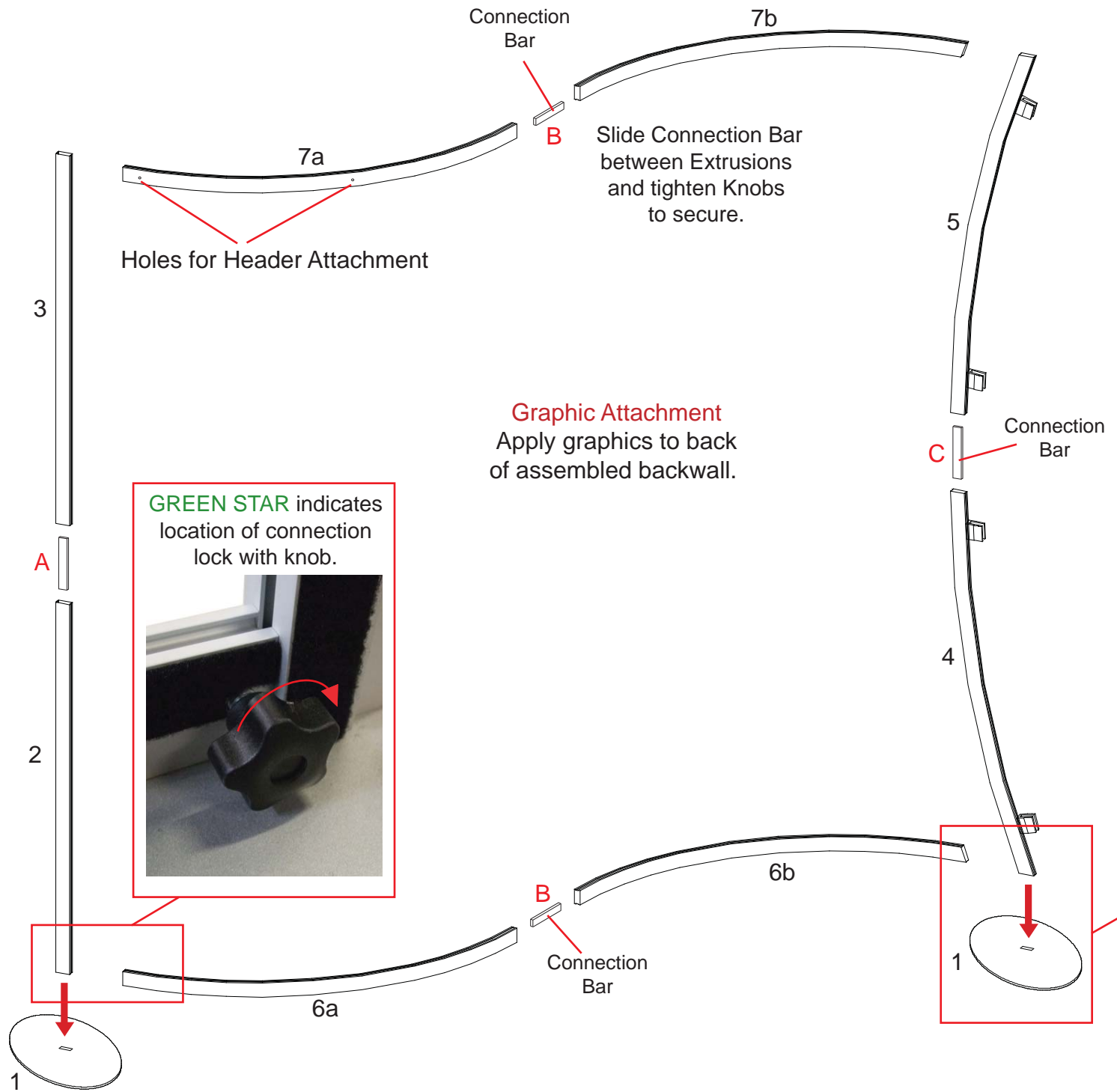

Graphic Attachment
Apply graphics to back of assembled backwall.

GREEN STAR indicates location of connection lock with knob.

RED STAR indicates location of connection bar with knobs on BACKSIDE of unit.

Rear View of Display

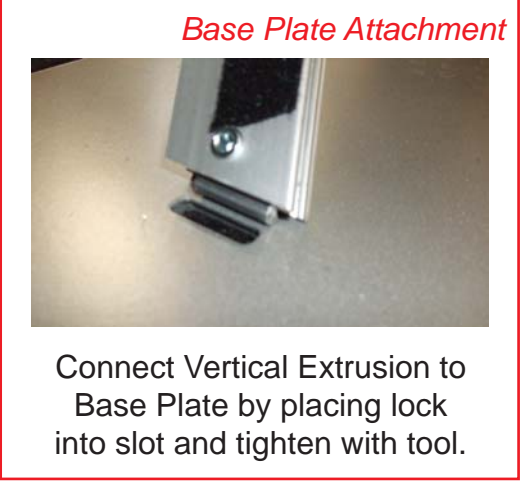
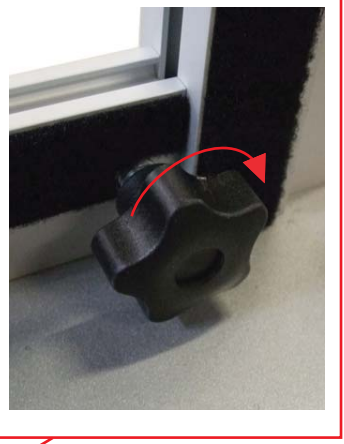
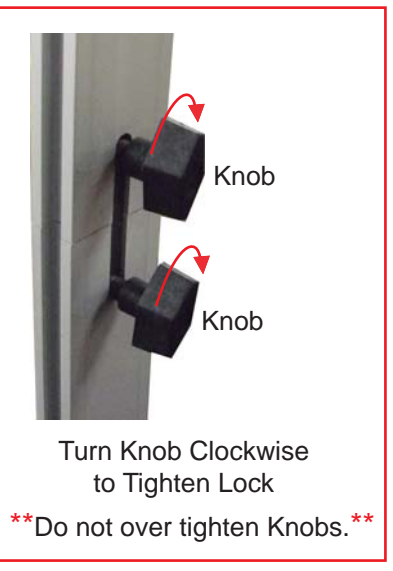
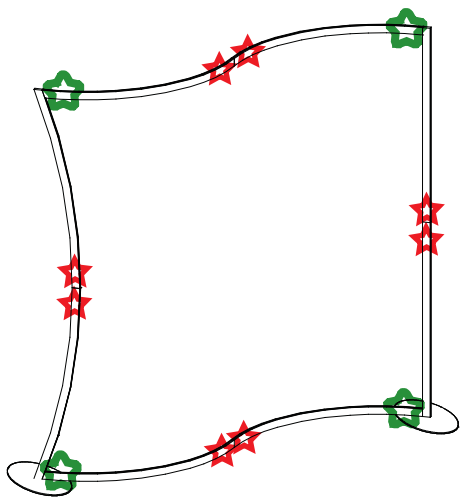

WHEN DISASSEMBLING ALUMINUM EXTRUSION, TIGHTEN ALL SETSCREWS AND LOCKS TO PREVENT LOSS DURING SHIPPING

Attach Header to Frame using Stand-off Caps.

Attach Wings to Assembled Frame using A10 Clamps.

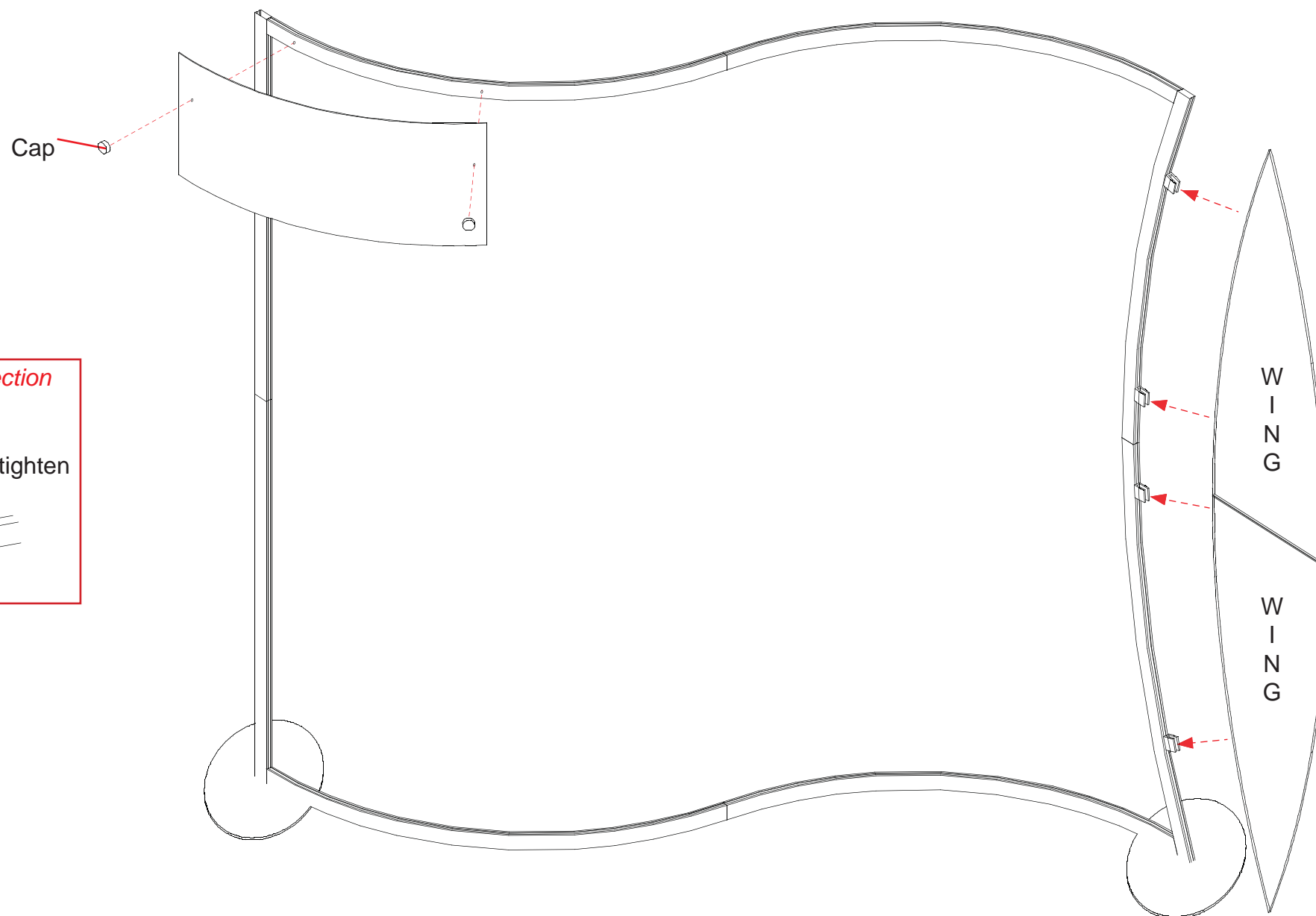

Cap

Light Connection
Attach Lights to Backwall where desired and tighten in place.

A small inset diagram shows a light fixture being attached to the backwall. The text indicates that lights should be attached where desired and tightened in place.

Wing Attachment
Slide A10 Clamp into groove of square extrusion.

A close-up diagram shows an 'A10' clamp being inserted into a groove in a square extrusion. A red arrow points downwards, indicating the direction of insertion.

When desired location is found, tighten set screw to secure.

A diagram shows a 'Set-Screw' being tightened on the wing attachment. A red arrow points to the set screw.

Tighten black plastic set screw to secure Wing in place.

A diagram shows a 'Black Plastic Set-screw' being tightened on the wing attachment. A red arrow points to the set screw.

WHEN DISASSEMBLING ALUMINUM EXTRUSION, TIGHTEN ALL SETSCREWS AND LOCKS TO PREVENT LOSS DURING SHIPPING

866.652.2100

Item	Qty.	Description
1	1	37.50" Vertical Extrusion
2	1	37.50" Vertical Extrusion
3	1	35" Vertical Extrusion
3a	1	Door Stop
4	1	37.50" Vertical Extrusion
5	2	35" Vertical Extrusion
6	2	Horizontal Extrusion w/ Lip
7	4	Horizontal Extrusion
8	1	Curved Horizontal Extrusion

- Steps**
- 1) Connect lower horizontal extrusions [5 and 7] between vertical extrusions [1, 2, 3 and 4] as shown.
 - 2) Attach door stop [3a] to lower curve extrusion [7] then attach door between extrusions [2 and 3a].
 - 3) Place insert panels where indicated.
 - 4) Attach upper vertical extrusion [8] atop lower vertical extrusion [3].
 - 5) Attach upper horizontal extrusions [6 and 7] between vertical extrusions [1, 2, 3 and 4] and atop inserts and door.
 - 6) Place shelf atop lip of extrusions [5].
 - 7) Set counter top on assembled pedestal.

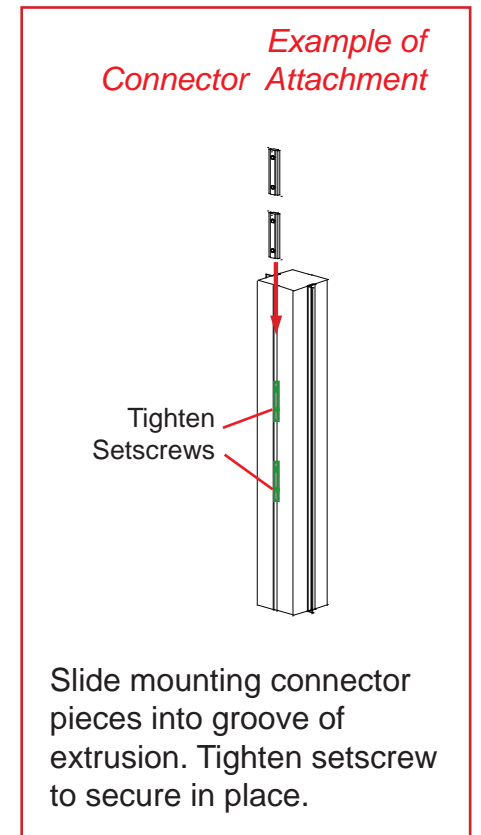
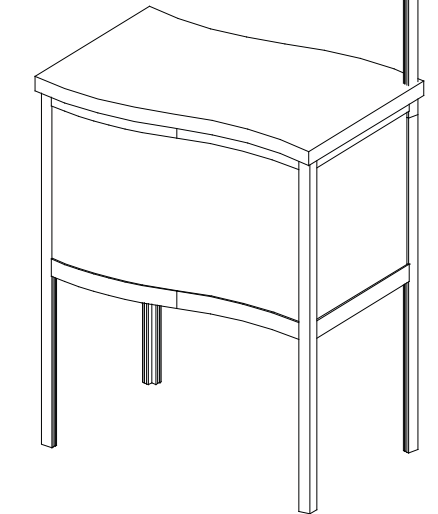
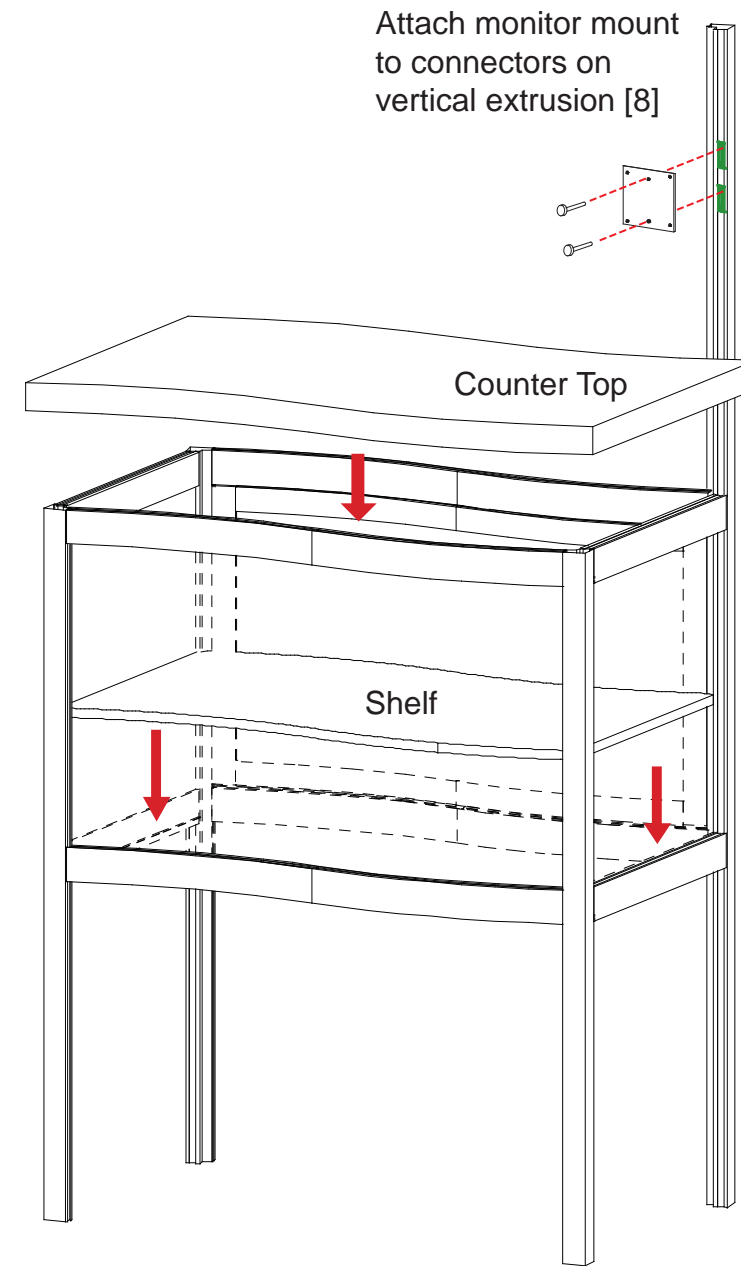
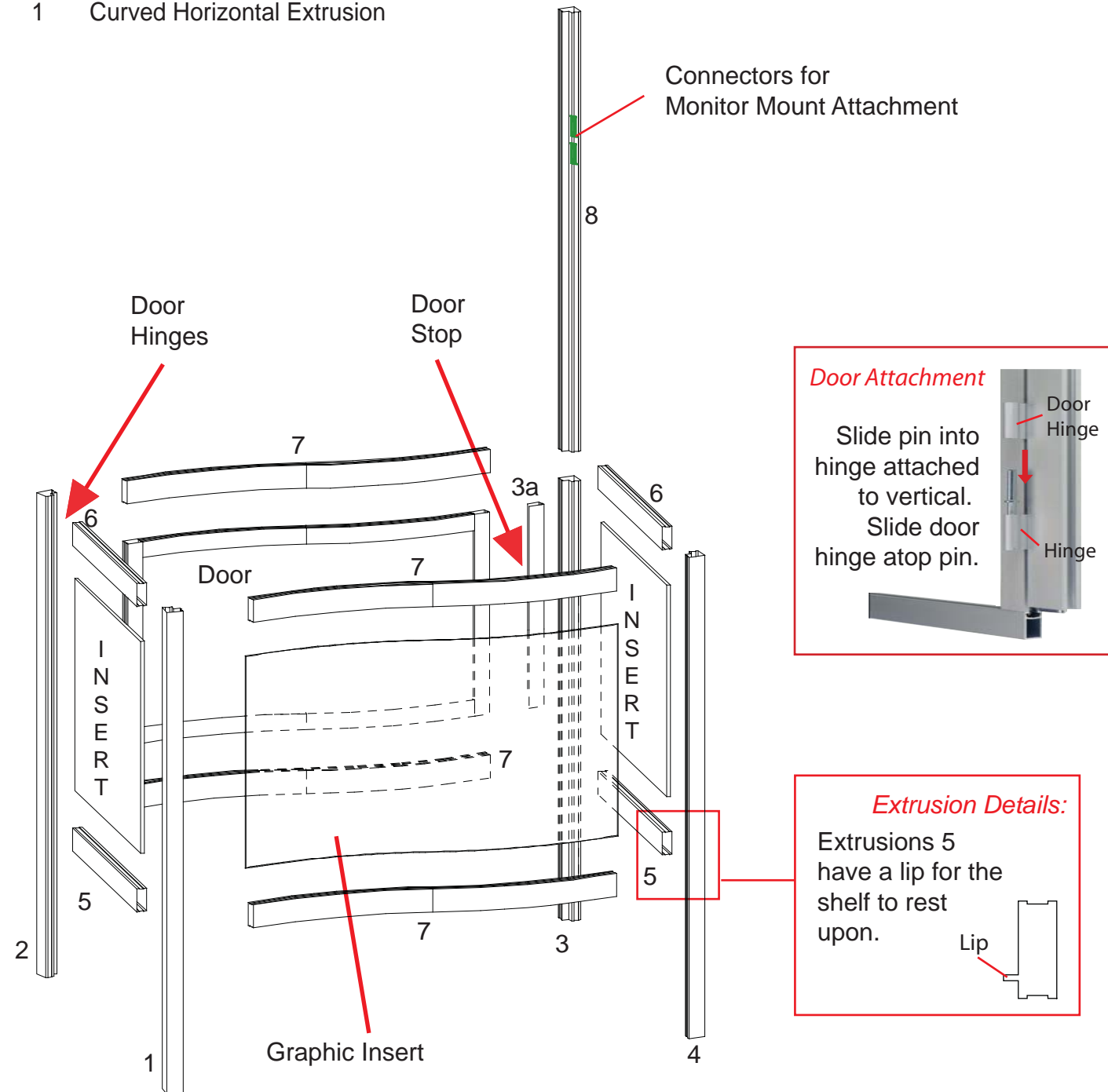

WHEN DISASSEMBLING ALUMINUM EXTRUSION, TIGHTEN ALL SETSCREWS AND LOCKS TO PREVENT LOSS DURING SHIPPING

Backwall Components

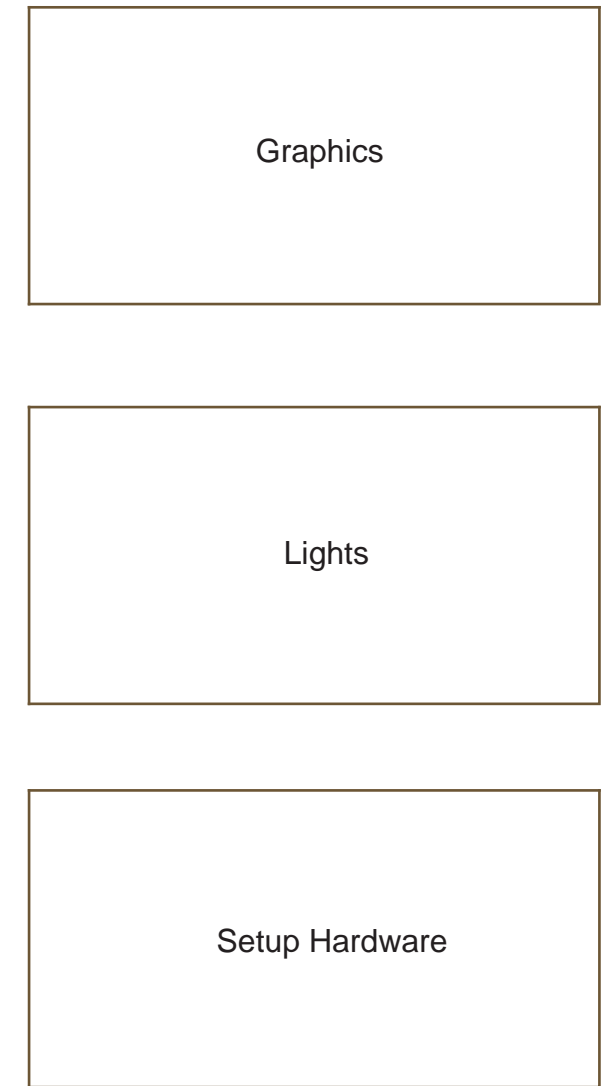
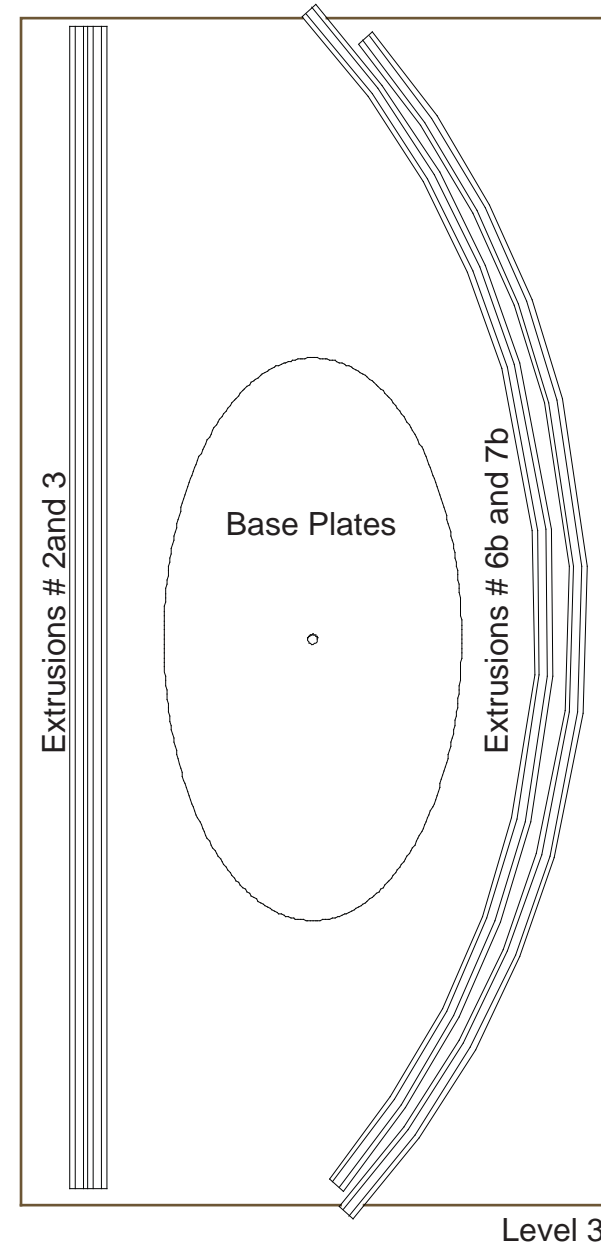
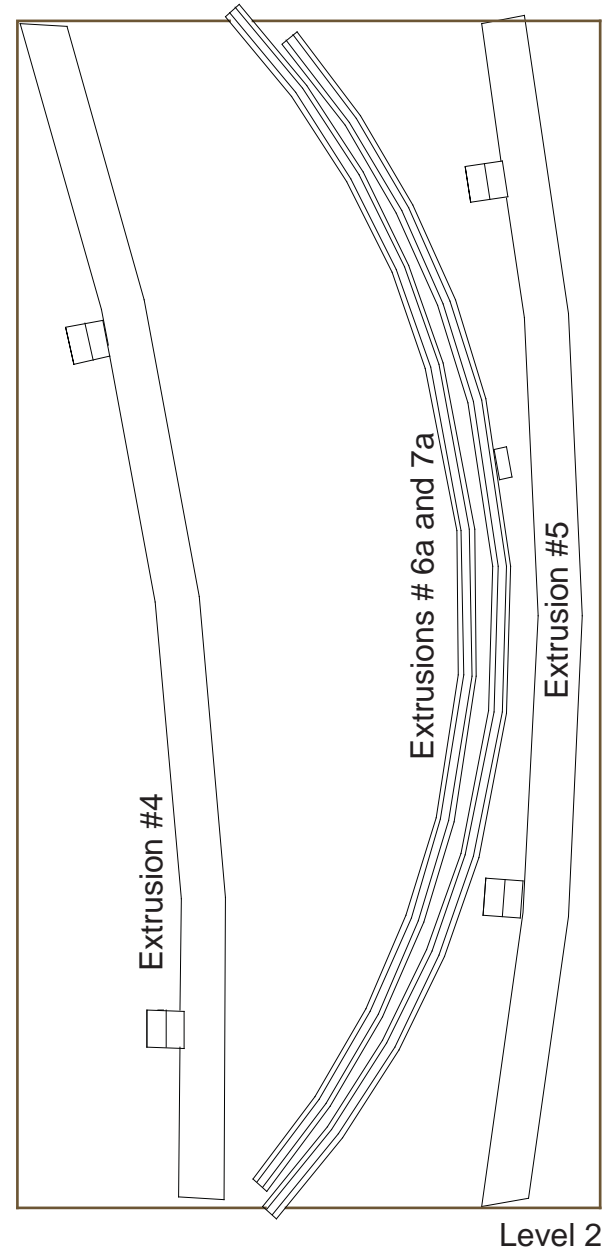
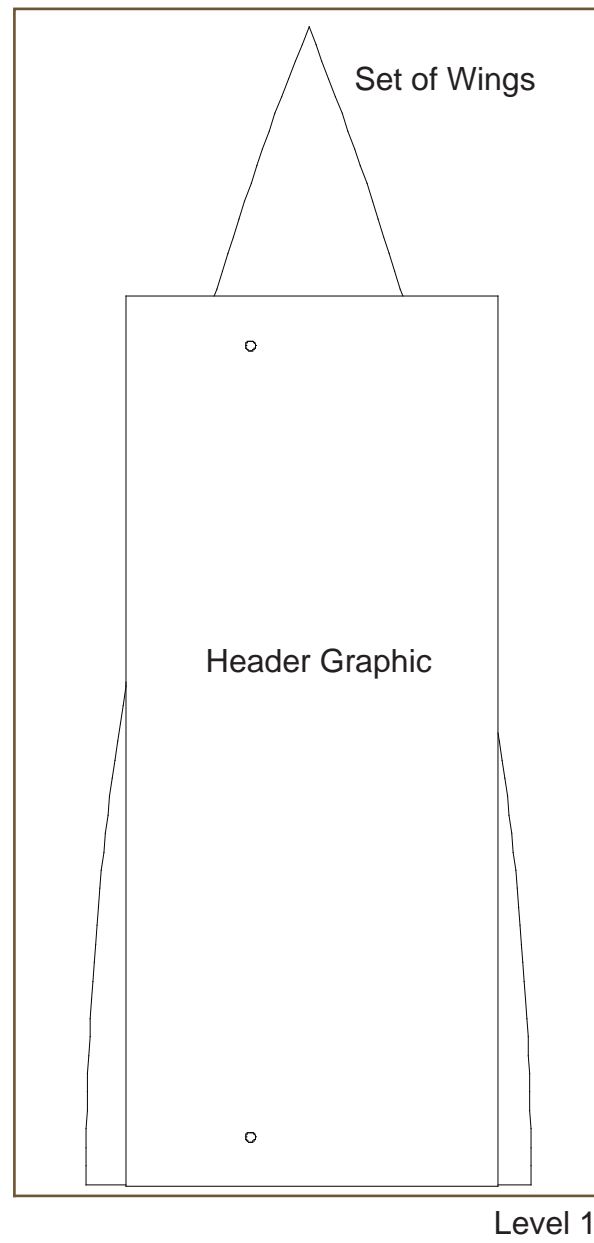

WHEN DISASSEMBLING ALUMINUM EXTRUSION, TIGHTEN ALL SETSCREWS AND LOCKS TO PREVENT LOSS DURING SHIPPING

MOD-1235 Components

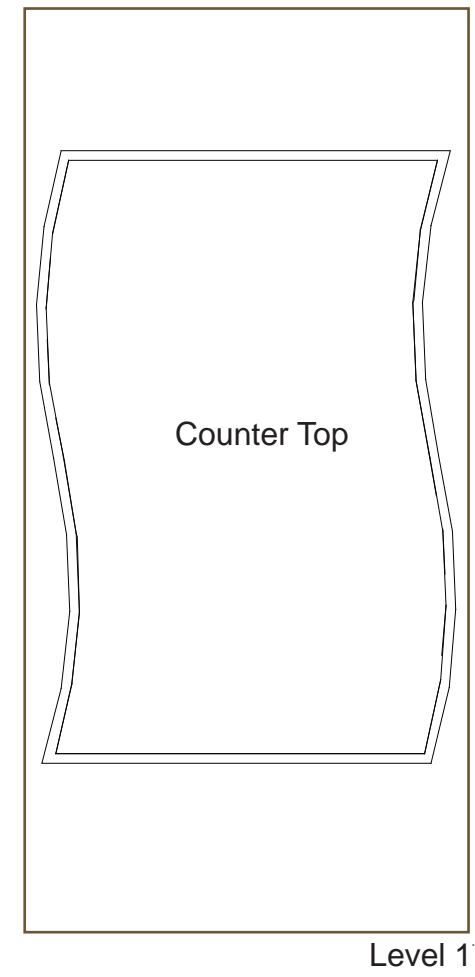
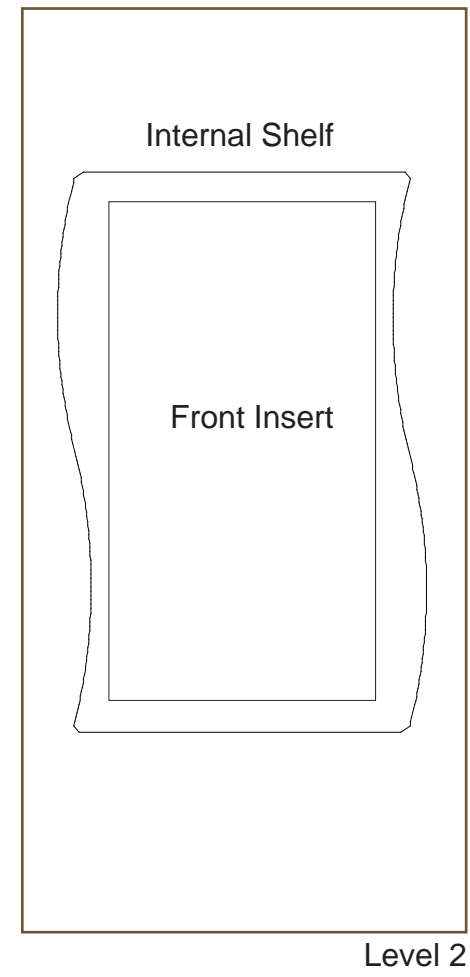
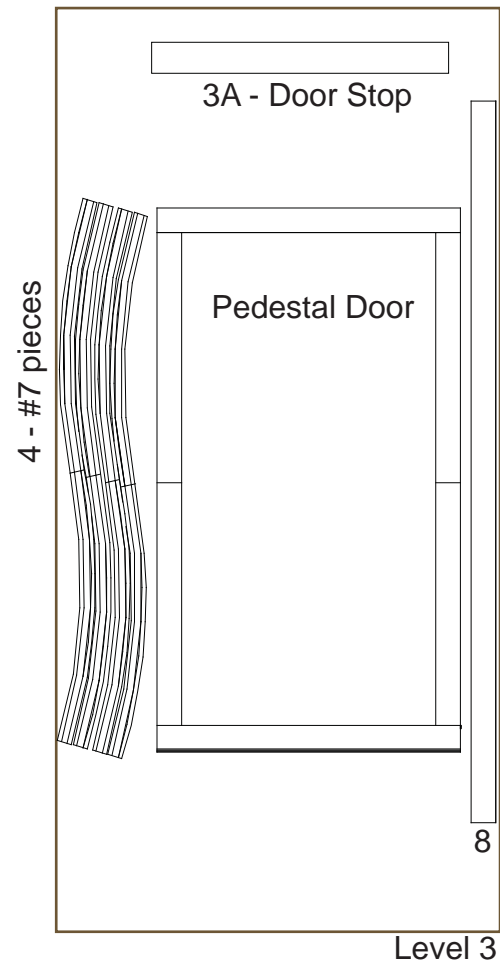
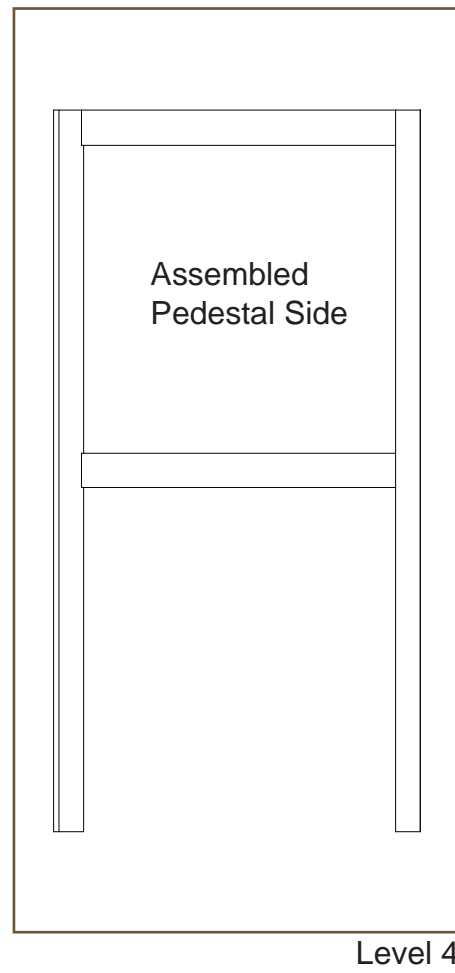
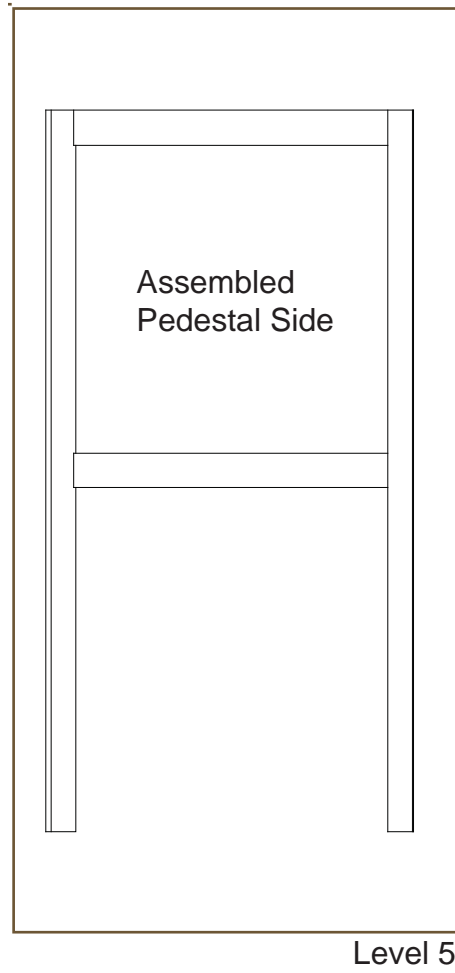

WHEN DISASSEMBLING ALUMINUM EXTRUSION, TIGHTEN ALL SETSCREWS AND LOCKS TO PREVENT LOSS DURING SHIPPING