

WHEN DISASSEMBLING ALUMINUM EXTRUSION, TIGHTEN ALL SETSCREWS AND LOCKS TO PREVENT LOSS DURING SHIPPING

# visionary™ DESIGNS

## Using Your Setup Instructions

The Visionary Designs Setup Instructions are created specifically for your configuration. They are laid out sequentially, including an exploded view of the entire display, and then a logical series of detailed steps to assemble the main structure and components. We encourage you to study the instructions **before** attempting to assemble your exhibit.

Each page reminds you to tighten the setscrews after disassembling your exhibit to prevent loss of the locks and setscrews (see below in RED). This is **VERY IMPORTANT**.

## Cleaning and Packing Your Display

- 1) Use care when cleaning aluminum extrusion or acrylic inserts. Use only non-abrasive cleaners.
- 2) When cleaning laminate inserts or countertops, use mild cleansers and a soft material such as cotton.
- 3) Keep all display components away from extreme heat and long exposure to sunlight to avoid warping and fading.
- 4) Retain all packing material. It will make re-packing much easier and will reduce the likelihood of shipping damage.



**The Tool**

Most Visionary Designs exhibits can be assembled with the supplied Hex Key Tool. Occasionally, a flat head screwdriver may be required.



**Typical Connection**



**Typical Connection (cont'd)**

Most horizontal extrusion connections have a patented expandable lock. This lock inserts into the groove of an opposing extrusion. Tightening the lock with the Hex Key Tool expands the lock and creates a strong positive connection.

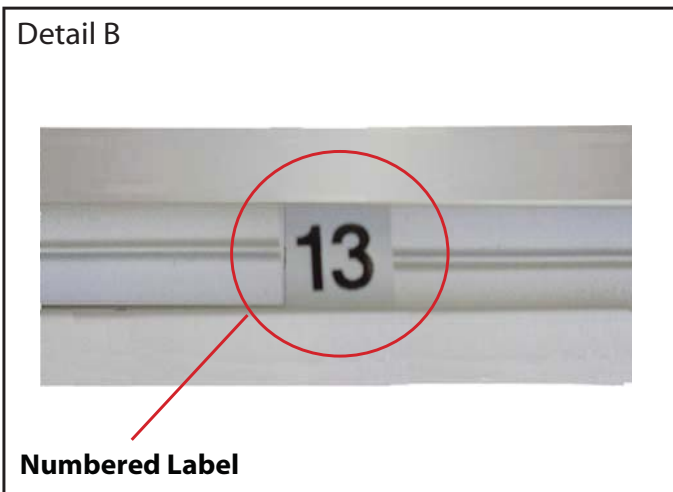

**Numbered Label**

Each extrusion contains a numbered label which corresponds with setup instructions. The label is located within a groove of the extrusion (when possible). With Visionary Designs the labels contain Black numbers unless otherwise specified.



**Horizontal Inline Connection** (remove only one setscrew)

Remove only (1) setscrew when disassembling. Replace setscrew in extrusion after assembling it. Before packing, replace setscrew in extrusion to avoid losing it.

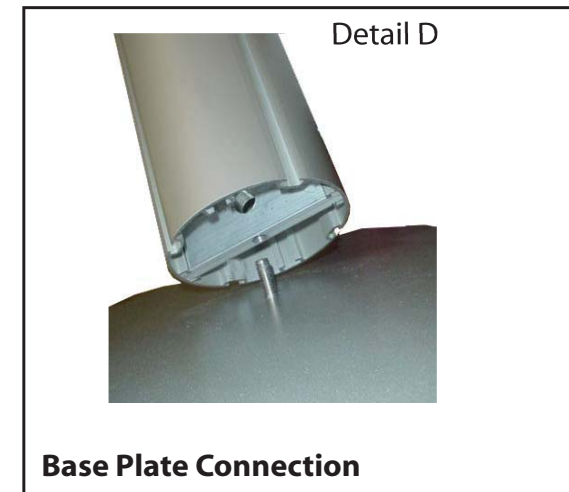

**Base Plate Connection**

Attach base plate to round or square vertical extrusion using the bolt provided. Be careful not to strip the threads.

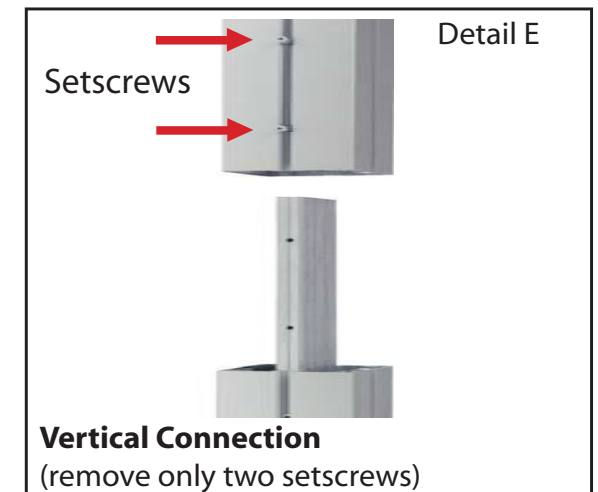

**Vertical Connection**  
(remove only two setscrews)

When vertical extrusions are packed in portable cases rather than crates or tubs, they must be broken down into smaller sections which then require assembly.

Remove only (2) setscrews when disassembling. Replace setscrews in extrusion after assembling it. Before packing, replace setscrews in extrusion to avoid losing them.

**WHEN DISASSEMBLING ALUMINUM EXTRUSION, TIGHTEN ALL SETSCREWS AND LOCKS TO PREVENT LOSS DURING SHIPPING**

Part Number	Qty	Description
1	3	Base Plate
2	3	47.75" Vertical Extrusion
3	3	48" Vertical Extrusion
4a/4b/4c	1/1/1	35.475" Curved Horizontal Extrusion
5a/5b/5c	1/1/1	35.475" Curved Horizontal Extrusion
6a/6b/6c	1/1/1	35.475" Curved Horizontal Extrusion
7a/7b/7c	1/1/1	35.475" Curved Horizontal Extrusion

Steps

- 1) Attach lower vertical extrusions [2] to base plates [1].
- 2) Connect upper vertical extrusions [3] to lower vertical extrusions [2].
- 3) Connect horizontal bars together [4a to 4b to 4c], [5a to 5b to 5c], [6a to 6b to 6c], and [7a to 7b to 7c].
- 4) Apply graphics to assembled frame.

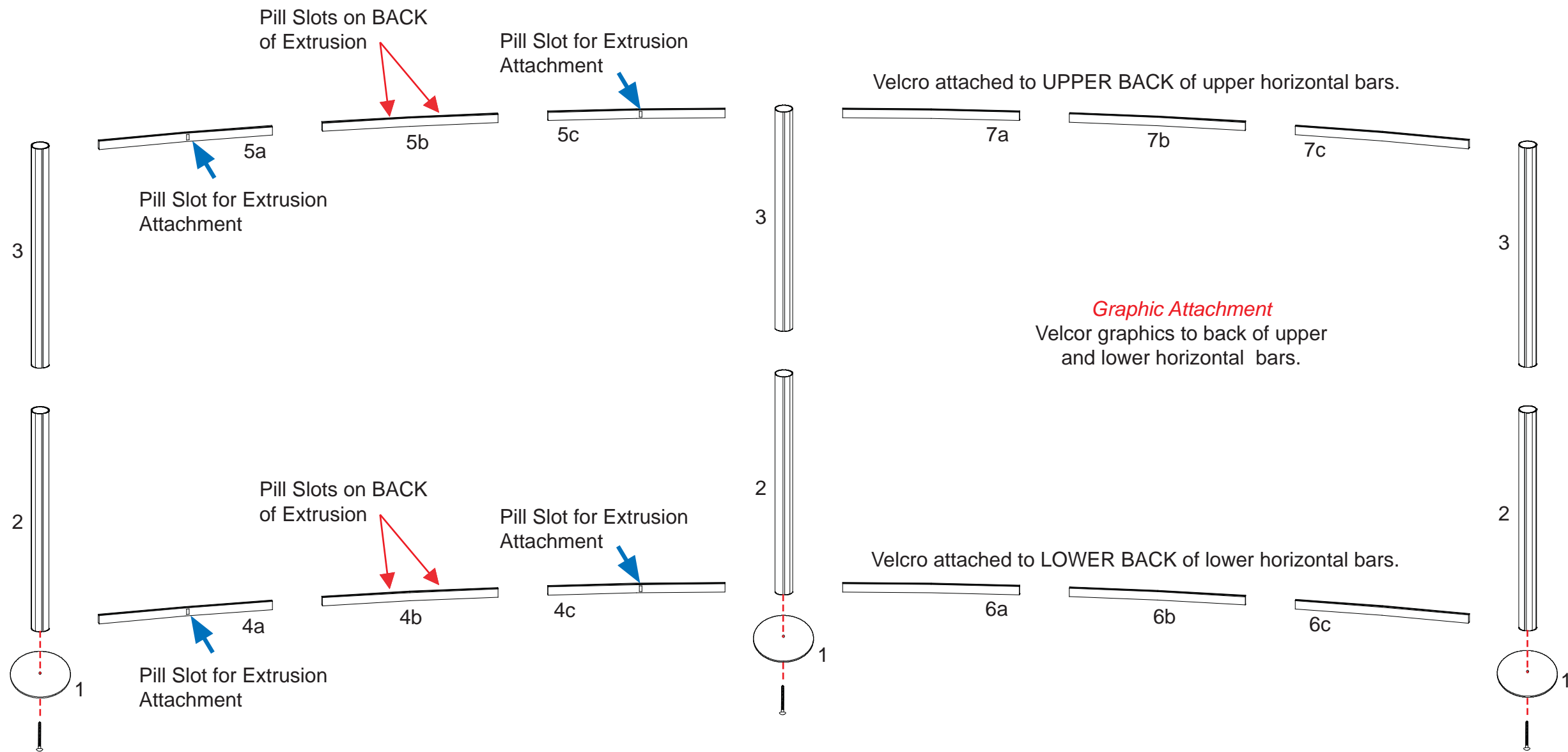

**WHEN DISASSEMBLING ALUMINUM EXTRUSION, TIGHTEN ALL SETSCREWS AND LOCKS TO PREVENT LOSS DURING SHIPPING**

866.652.2100

Part Number	Qty	Description
8	4	6" Horizontal Extrusion
9	2	48"h Vertical Extrusion
10	2	48"h Vertical Extrusion
11	4	1.5" Horizontal Extrusion
21	2	8"w Horizontal Extrusion

**Front Side of Backwall**

**Back Side of Backwall**

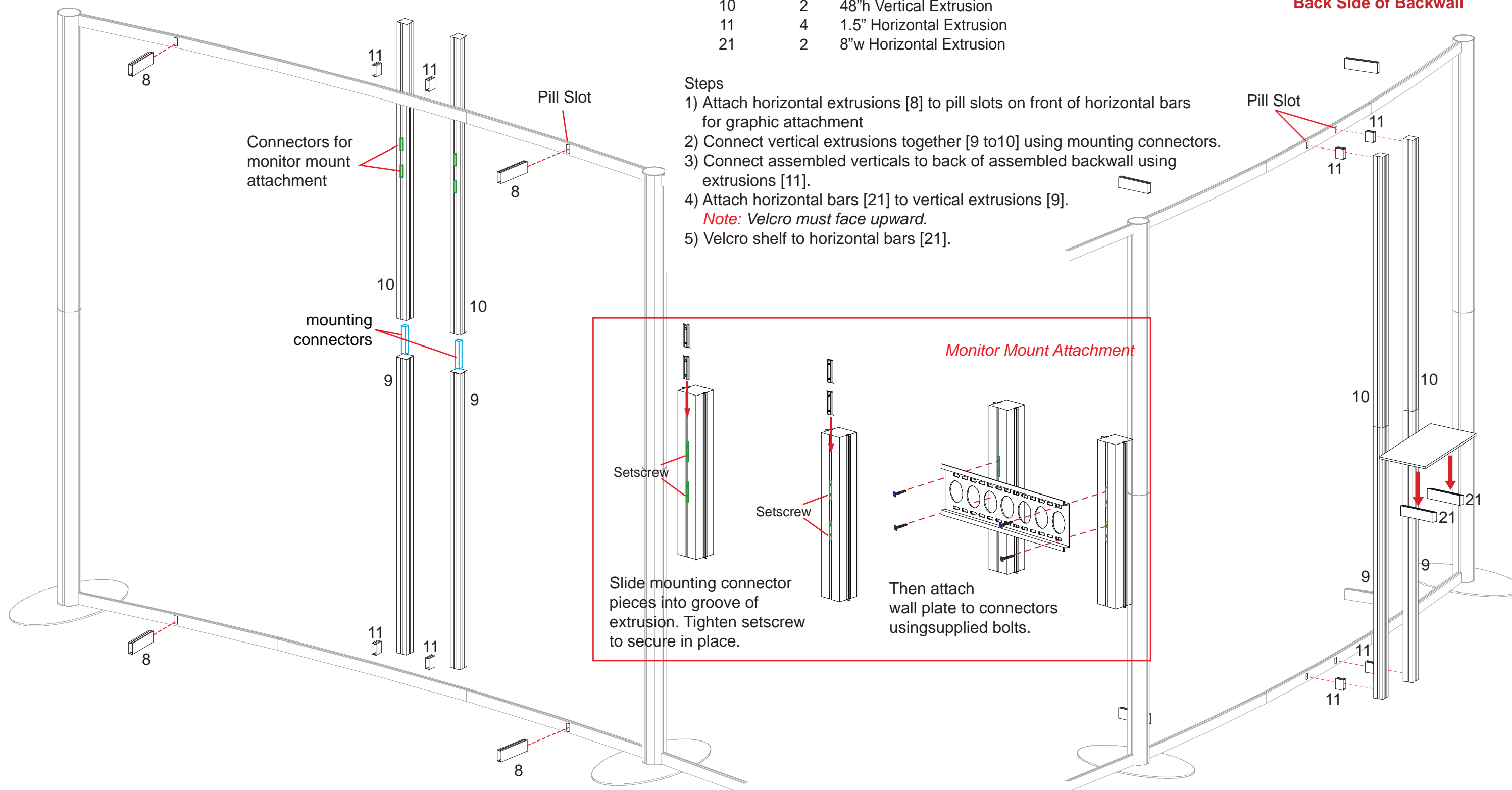

- Steps**
- 1) Attach horizontal extrusions [8] to pill slots on front of horizontal bars for graphic attachment
  - 2) Connect vertical extrusions together [9 to 10] using mounting connectors.
  - 3) Connect assembled verticals to back of assembled backwall using extrusions [11].
  - 4) Attach horizontal bars [21] to vertical extrusions [9].
- Note: Velcro must face upward.*
- 5) Velcro shelf to horizontal bars [21].

**Monitor Mount Attachment**

Slide mounting connector pieces into groove of extrusion. Tighten setscrew to secure in place.

Then attach wall plate to connectors using supplied bolts.

**WHEN DISASSEMBLING ALUMINUM EXTRUSION, TIGHTEN ALL SETSCREWS AND LOCKS TO PREVENT LOSS DURING SHIPPING**

Steps:

1) Attach Gyford System with graphics to FRONT horizontal bars [8], see next page for Gyford installation instruction.

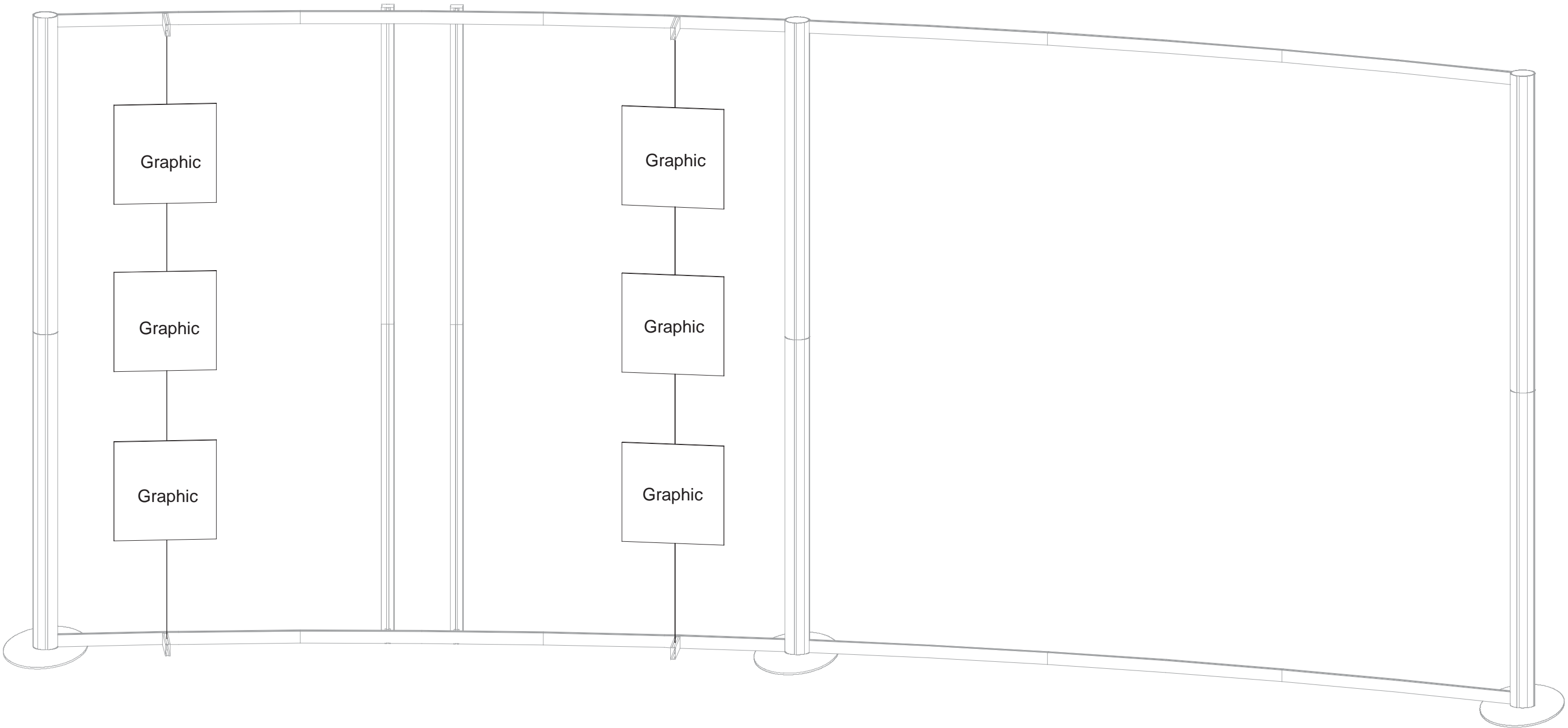

WHEN DISASSEMBLING ALUMINUM EXTRUSION, TIGHTEN ALL SETSCREWS AND LOCKS TO PREVENT LOSS DURING SHIPPING

### How To: Extrusion Profile Assemblies



Insert and lock the Custom Nut into position on the Profile



Wire is cut to length and inserted into the Turnbuckle top nut.



Attach and tension the wire and Turnbuckle top nut on the assembly



Complete the assembly by tightening both jam nuts on the Turnbuckle



This is a basic assembly for attaching Wire Suspension parts to extruded StructureLite Profiles.

NAVIGATION

[Web Site Link](#)

CONTENTS

- Wire & Wire Connectors
- Shelf Clips & Connectors
- Shelf Hub & Turnbuckle Assy's
- Spreader Bars & Mounting Plates
- Pulley Holders
- Pulley Wheel & Pulley Assy's
- Wire Shelf Clips, Hub & Assy's
- Econo Hinges
- Econo Grippers
- Econo Saddle & Panel Grippers
- Wire Turnbuckle Assemblies
- Shelf Clip, Hinge Assembly
- Assemblies for Extrusions
- Assemblies for Extrusions
- Truss Clamps

index

## Assemblies for Extrusions

Parts include everything shown unless otherwise noted.  
Wire Suspension parts are for use with 3/64" WS-Wire, Wire sold separately

Note: Extruded Profiles sold separately, (see Structurelite Pg. 101)  
Note: Wire sold separately, (see Pg. EZ-Rod pg. 63)

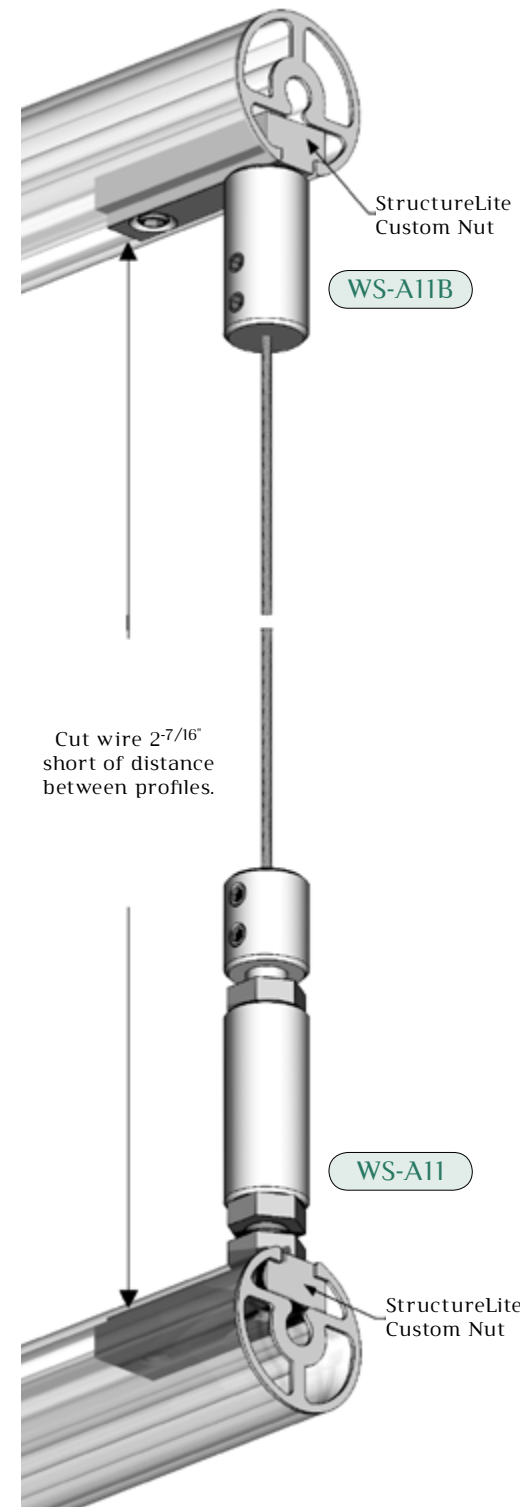

### Threaded Wire Connector, Turnbuckle & Custom Nut Assemblies

Part	
WS-A11B	Upper Mount
WS-A11	Lower Mount

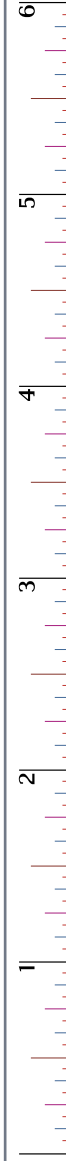

### How To: Econo Saddle & Panel Grippers

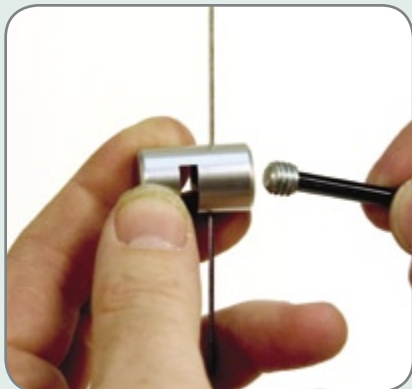

You may want to tighten the gripper on the wire before attaching the panel because the wire can be turned to give access to the set screw.



Set panel in the seats of the Saddle Grippers and tighten the included set screws to fasten in place.



A Nylon Tip set screw is used to secure a plexiglass panel to the Saddle Gripper.



Econo Saddle Grippers are a simple way to hang signs and graphics without drilling holes in them.



Econo Panel Grippers are an excellent way to hang signs or banners from a standard T-bar ceiling grid using our HD-DCLIP drop ceiling clip.



NAVIGATION

Web Site Link

CONTENTS

- Wire & Wire Connectors
- Shelf Clips & Connectors
- Shelf Hub & Turnbuckle Assy's
- Spreader Bars & Mounting Plates
- Pulley Holders
- Pulley Wheel & Pulley Assy's
- Wire Shelf Clips, Hub & Assy's
- Econo Hinges
- Econo Grippers
- Econo Saddle & Panel Grippers
- Wire Turnbuckle Assemblies
- Shelf Clip, Hinge Assembly
- Assemblies for Extrusions
- Assemblies for Extrusions
- Truss Clamps

index

## Econo Saddle & Panel Grippers

Parts include everything shown unless otherwise noted.  
Wire Suspension parts are for use with 3/64" WS-Wire, Wire sold separately

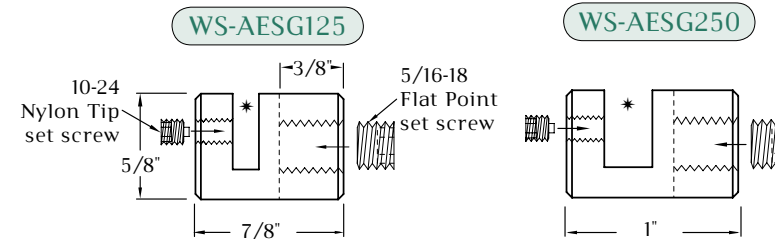

\* See chart for size

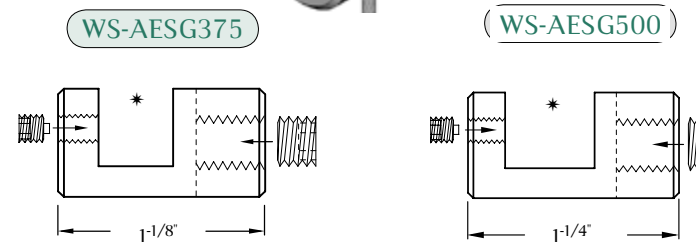
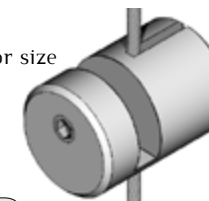

### Econo Saddle Grippers

Part	Holds	Slot Width
WS-AESG125	1/8" panel	.155
WS-AESG250	1/4" panel	.288
WS-AESG375	3/8" panel	.405
WS-AESG500	1/2" panel	.530

### WS-AEPG125

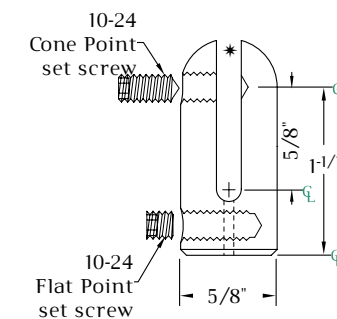
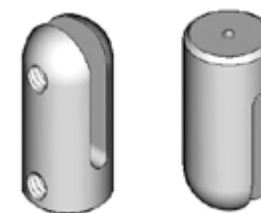

\* See chart for size

### WS-AEPG250

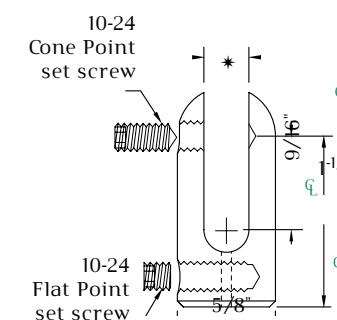
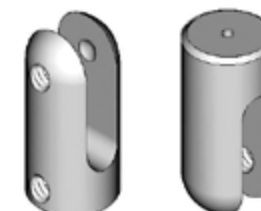

### Econo Panel Grippers

Part	Holds	Slot Width
WS-AEPG125	1/8" panel	.155
WS-AEPG250	1/4" panel	.265



866.652.2100

Part Number	Qty	Description
12	1	39.5" Vertical Extrusion w/ Door Hinges
13	1	39.5" Vertical Extrusion
14	1	39.5" Vertical Extrusion w/ Door Stop
15	1	39.5" Vertical Extrusion
16	8	20.25" Horizontal Extrusion
17	1	39" Round Vertical Extrusion

Steps

- 1) Attach lower horizontal extrusions [16] between vertical extrusions.
- 2) Place graphic infills between vertical extrusions where indicated.
- 3) Attach door to to back of base.
- 4) Attach upper horizontal extrusions atop infills and door.
- 5) Attach vertical extrusion [17] to counter top.
- 6) Set counter top on assembled base.

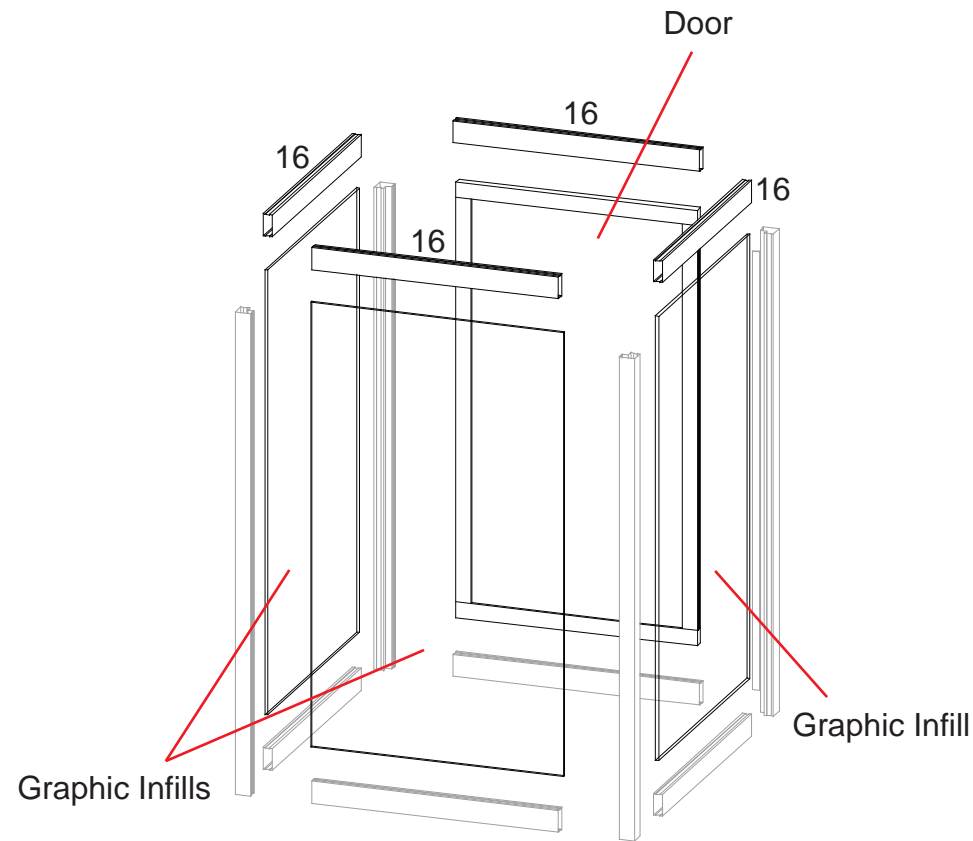
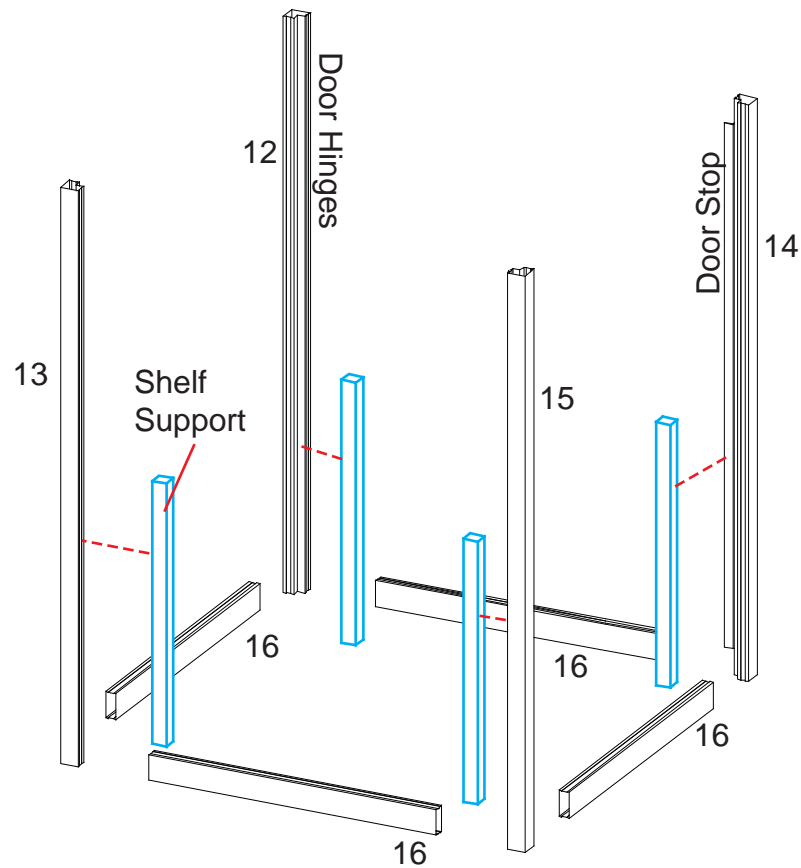

**Counter Top Attachment**

Attach vertical extrusion [17] to underside of counter top as shown. Then set counter top on assembled base.

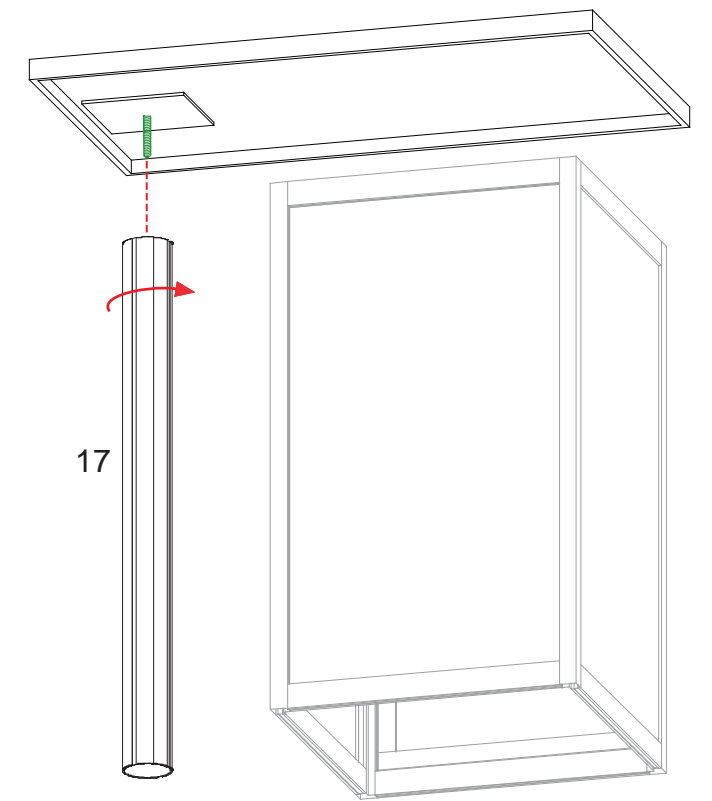

**WHEN DISASSEMBLING ALUMINUM EXTRUSION, TIGHTEN ALL SETSCREWS AND LOCKS TO PREVENT LOSS DURING SHIPPING**

866.652.2100

Part Number	Qty	Description
19	1	Base Plate
20	1	39.25"h Round Vertical Extrusion

- Steps
- 1) Attach round vertical extrusion [20] to base plate [19].
  - 2) Screw counter top to top of round vertical extrusion.
  - 3) Repeat steps for additional table.

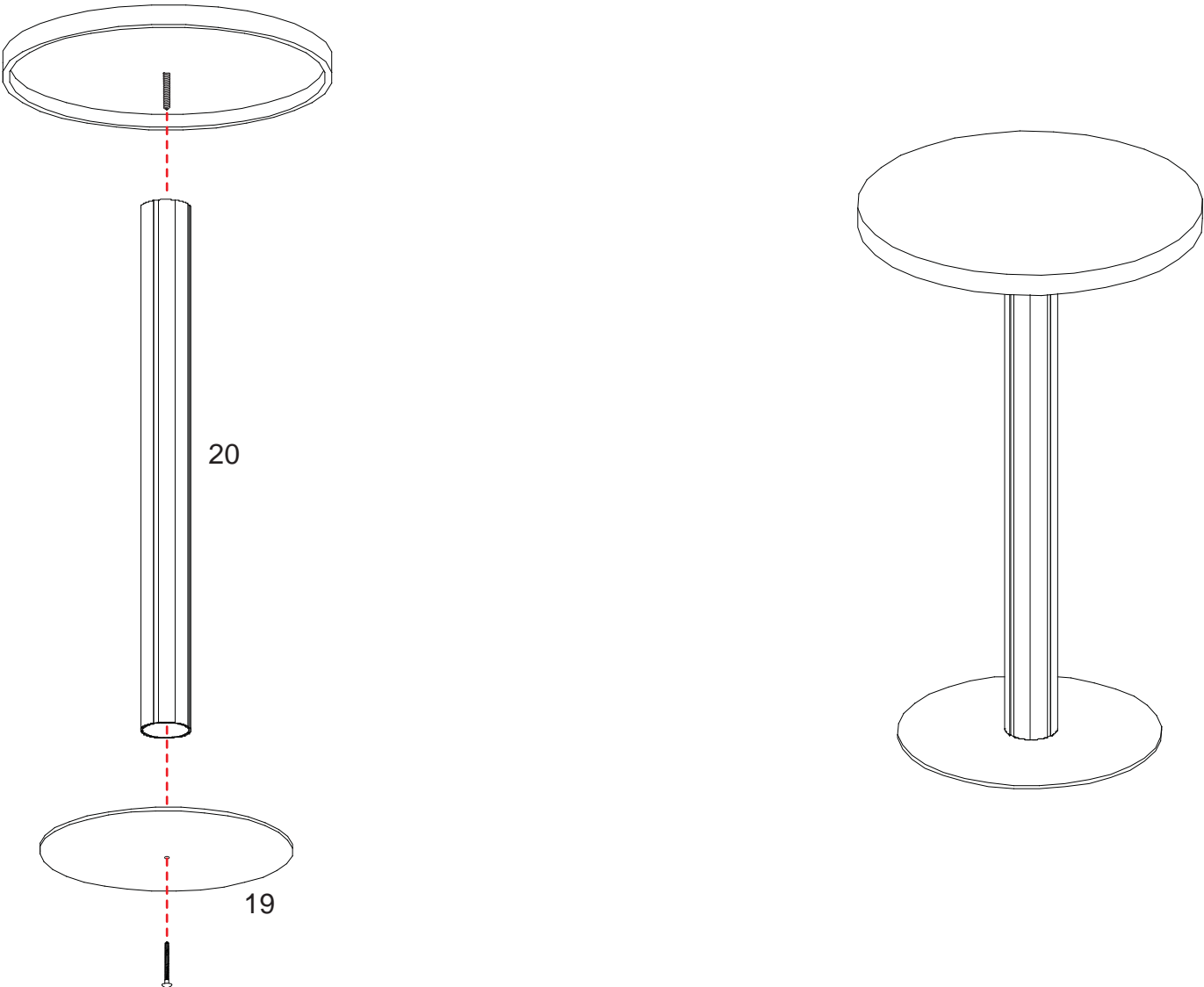

WHEN DISASSEMBLING ALUMINUM EXTRUSION, TIGHTEN ALL SETSCREWS AND LOCKS TO PREVENT LOSS DURING SHIPPING

Top view of each level

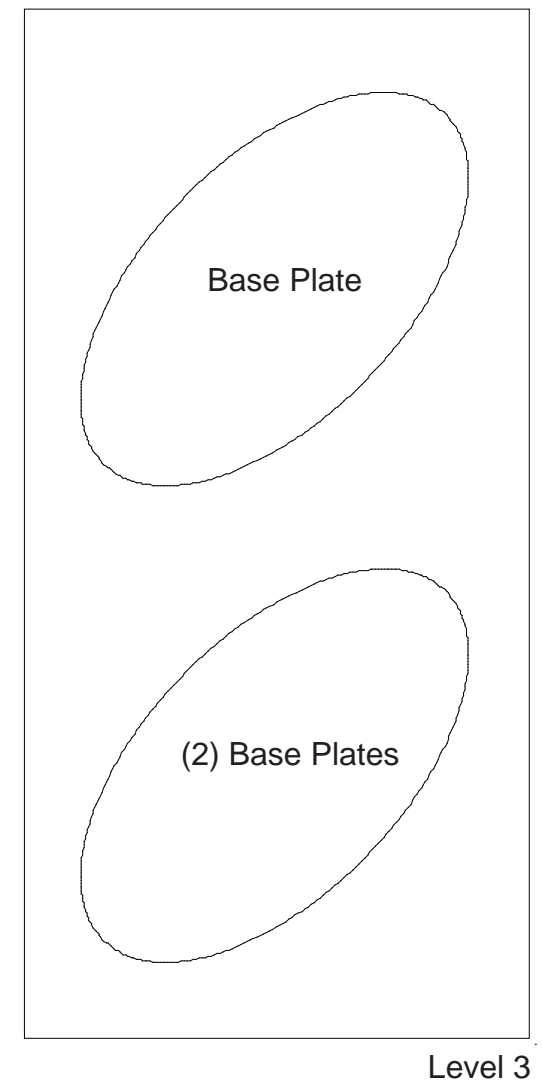
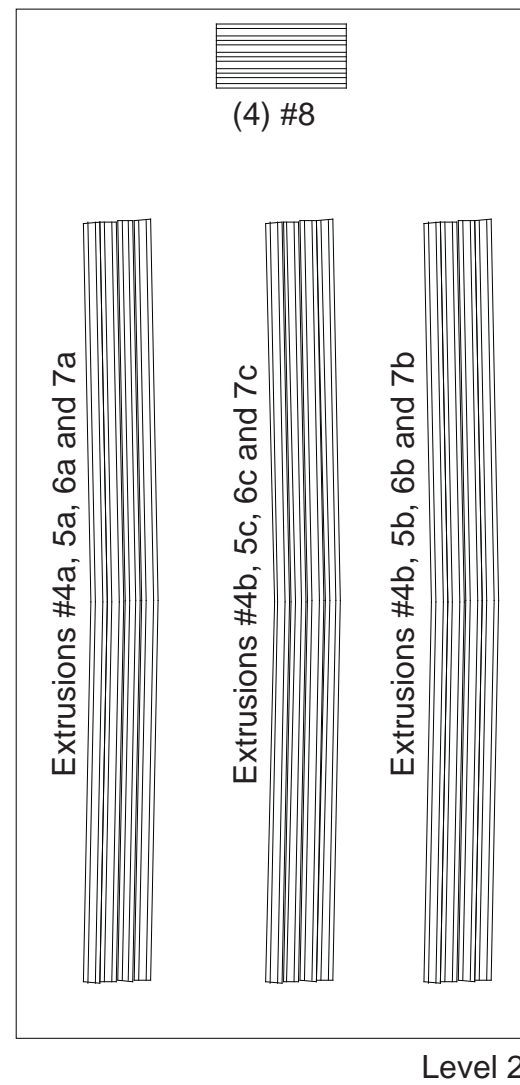
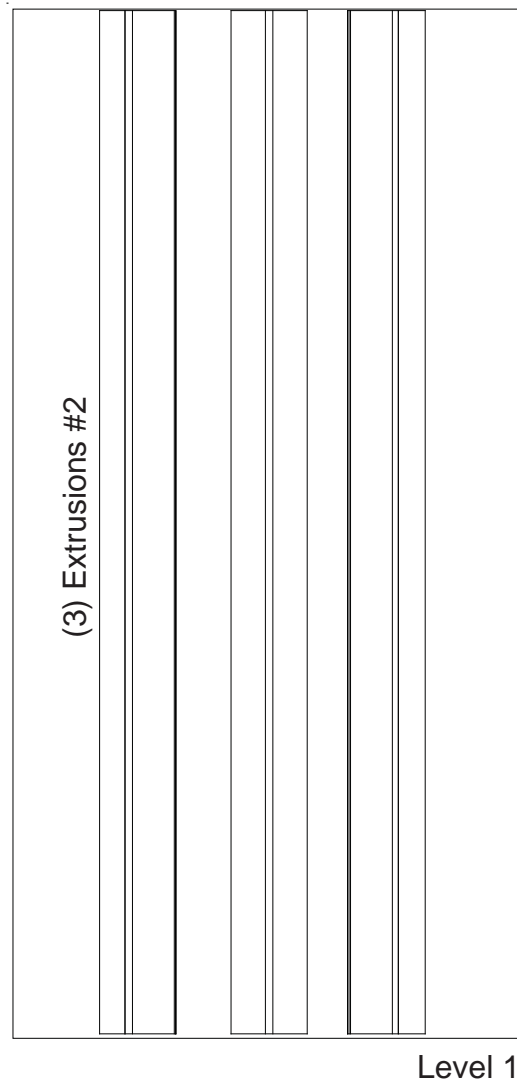

WHEN DISASSEMBLING ALUMINUM EXTRUSION, TIGHTEN ALL SETSCREWS AND LOCKS TO PREVENT LOSS DURING SHIPPING

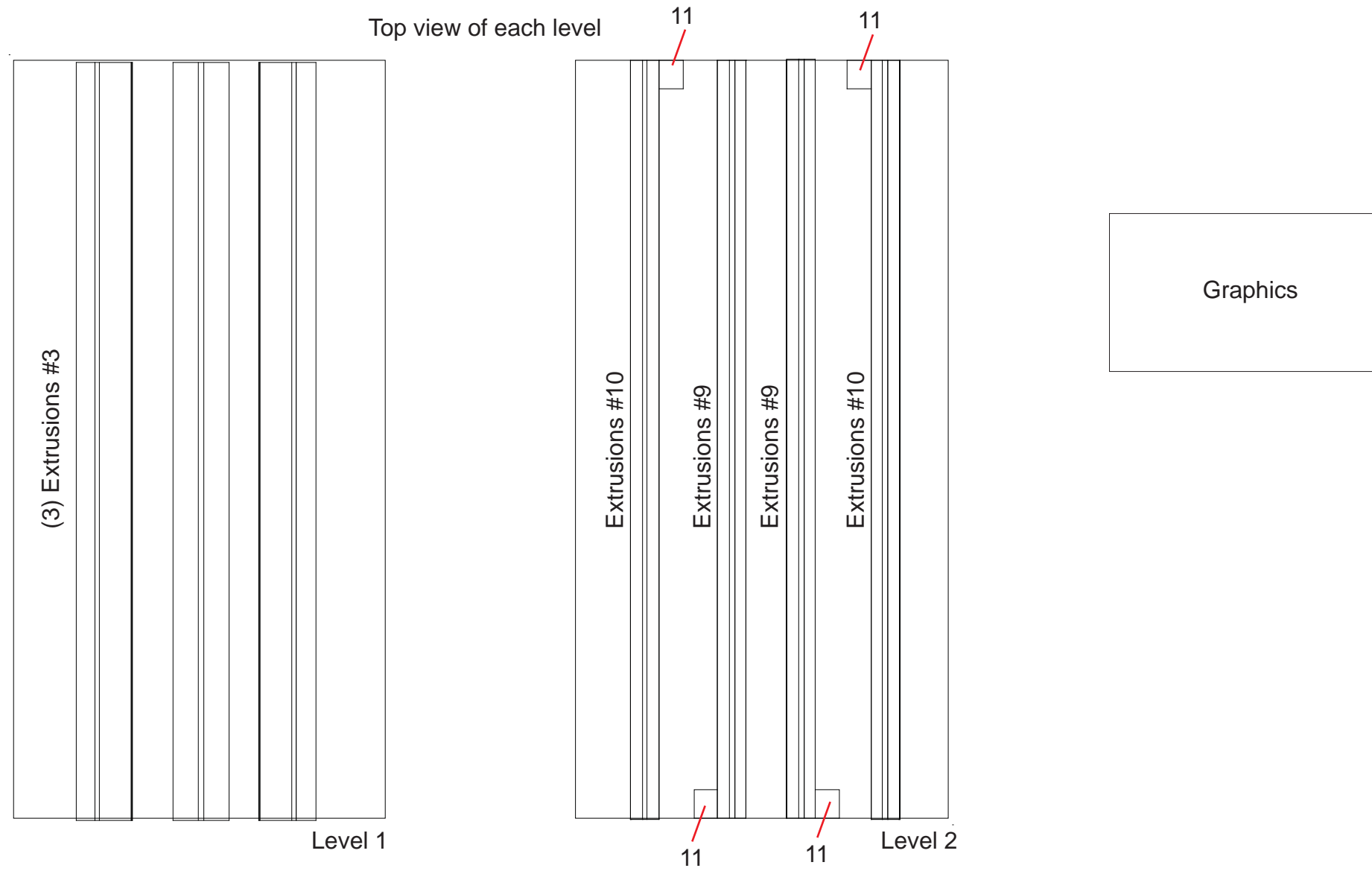

WHEN DISASSEMBLING ALUMINUM EXTRUSION, TIGHTEN ALL SETSCREWS AND LOCKS TO PREVENT LOSS DURING SHIPPING

Top view of each level

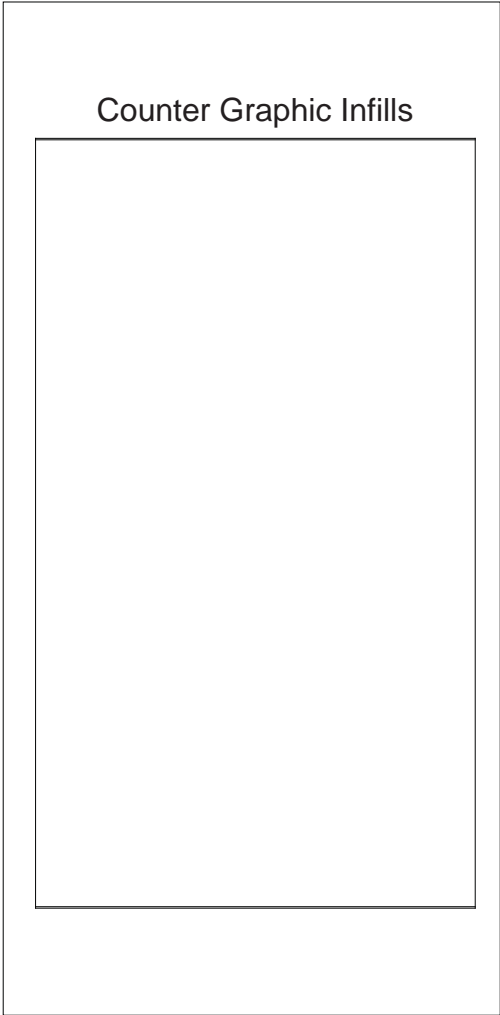

Level 1

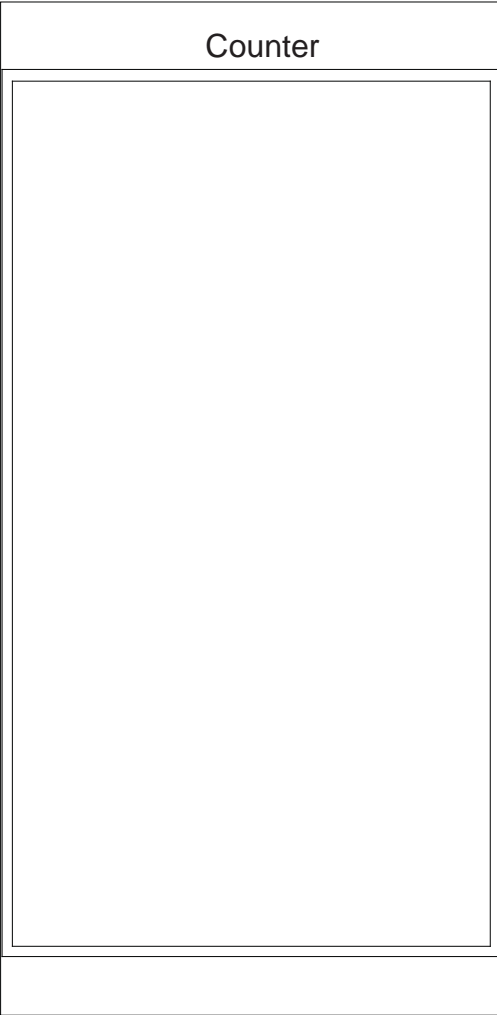

Level 2

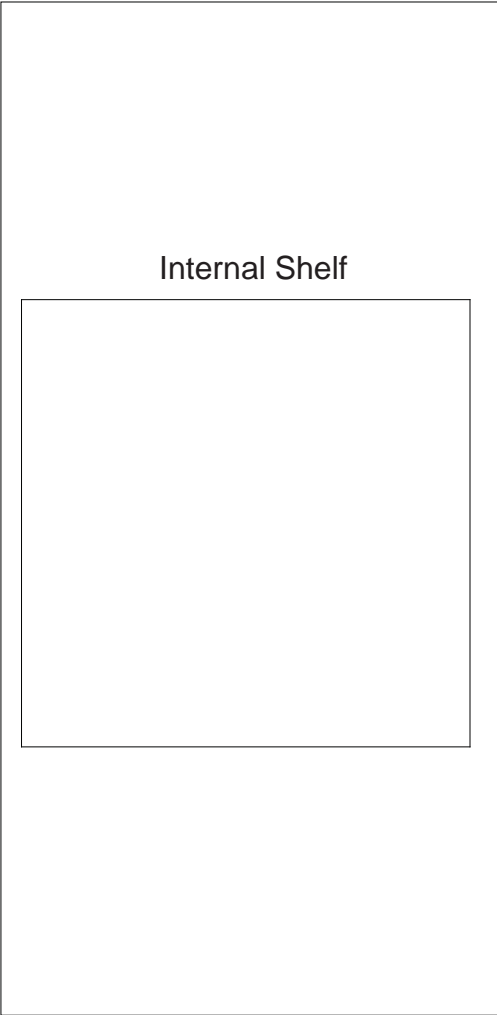

Level 3

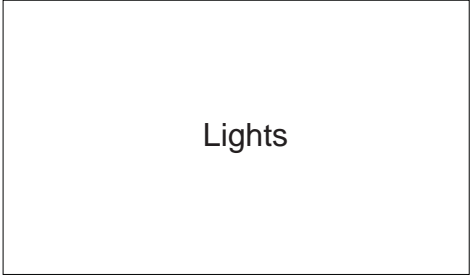

WHEN DISASSEMBLING ALUMINUM EXTRUSION, TIGHTEN ALL SETSCREWS AND LOCKS TO PREVENT LOSS DURING SHIPPING

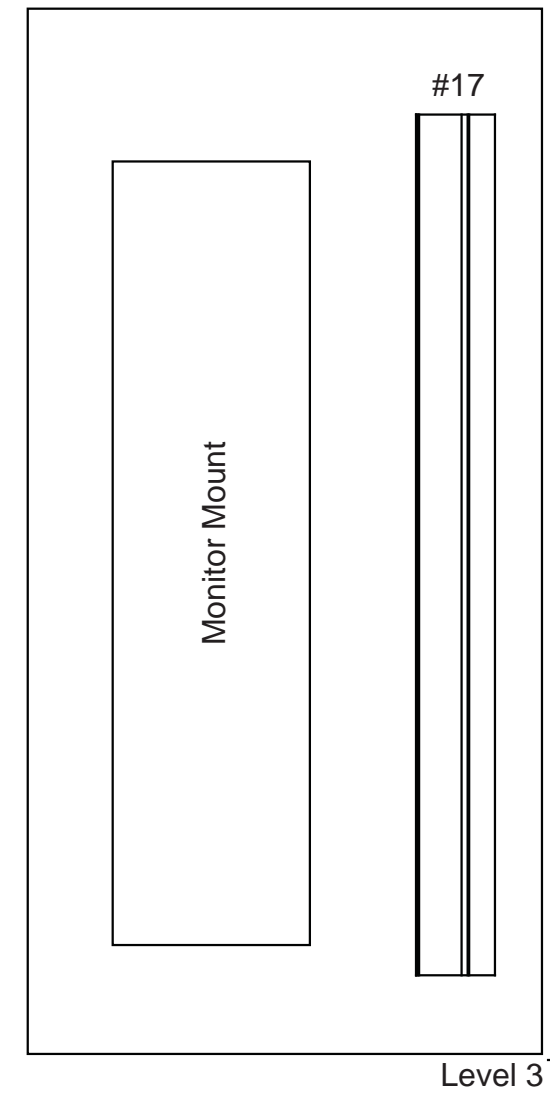
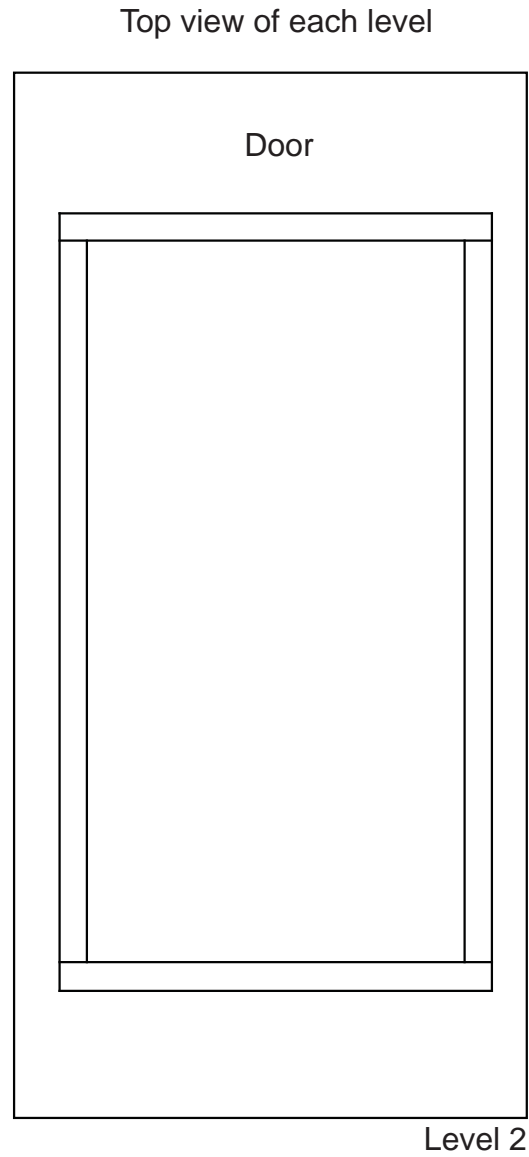
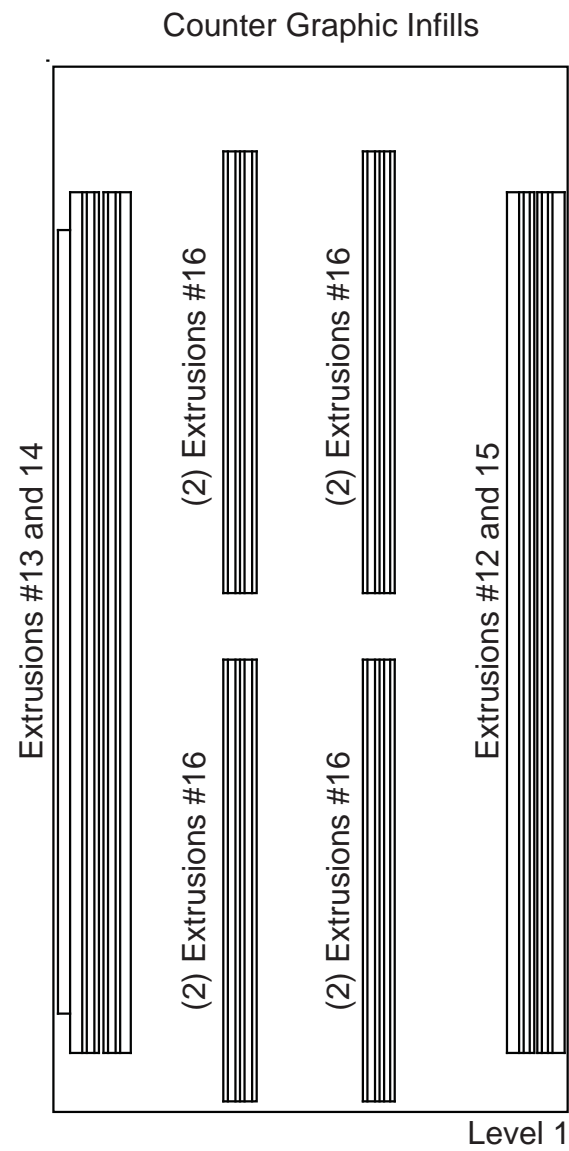

WHEN DISASSEMBLING ALUMINUM EXTRUSION, TIGHTEN ALL SETSCREWS AND LOCKS TO PREVENT LOSS DURING SHIPPING

Top view of each level

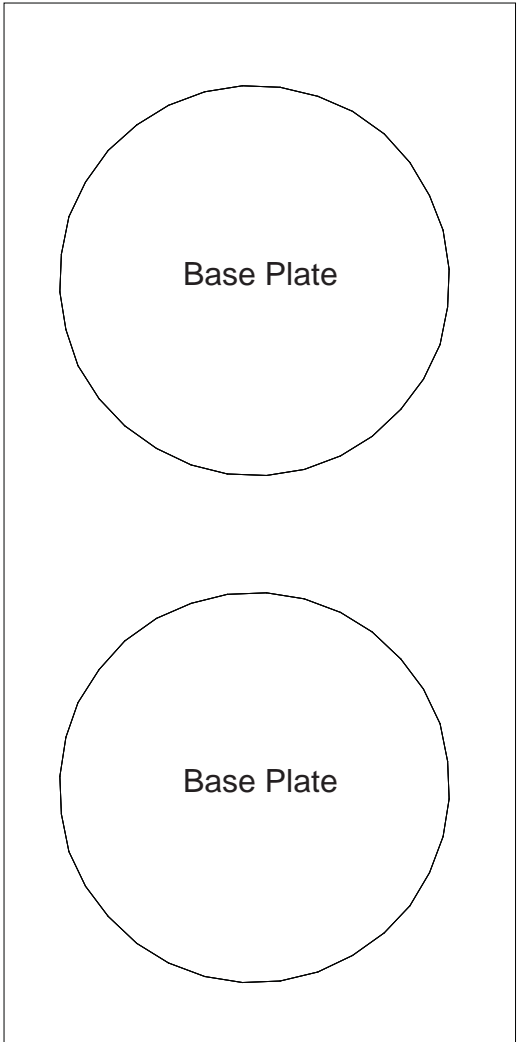

Level 1

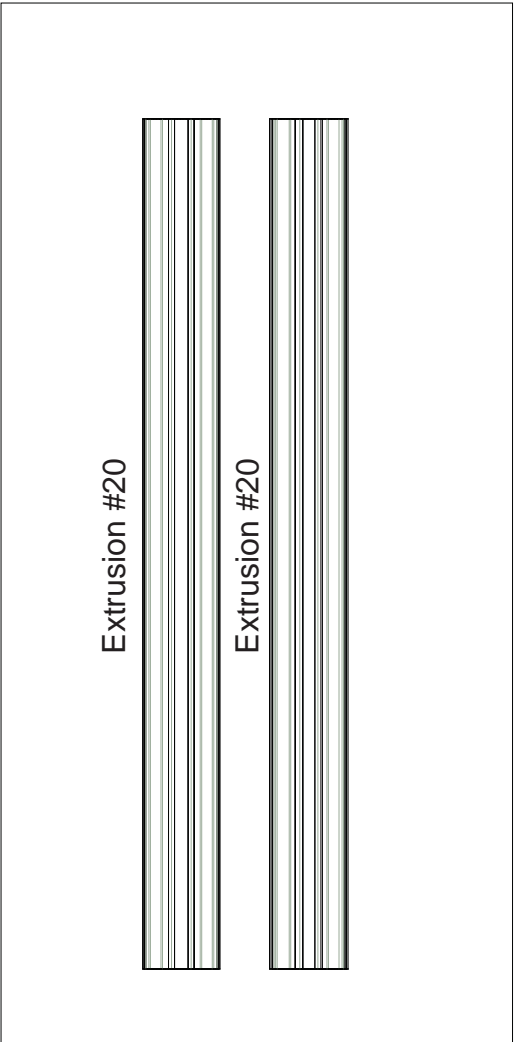

Level 2

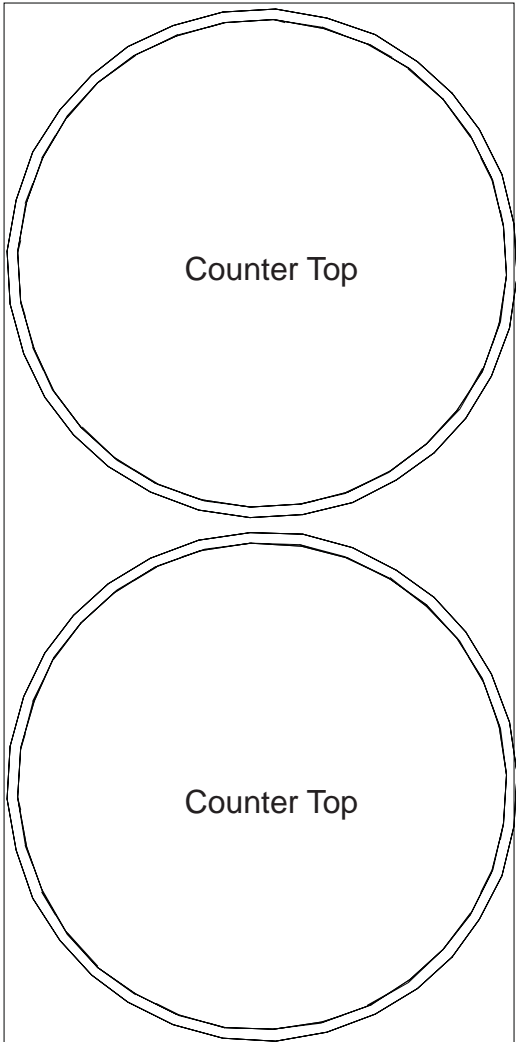

Level 3

**WHEN DISASSEMBLING ALUMINUM EXTRUSION, TIGHTEN ALL SETSCREWS AND LOCKS TO PREVENT LOSS DURING SHIPPING**