

WHEN DISASSEMBLING ALUMINUM EXTRUSION, TIGHTEN ALL SETSCREWS AND LOCKS TO PREVENT LOSS DURING SHIPPING

visionary™ DESIGNS

Using Your Setup Instructions

The Visionary Designs Setup Instructions are created specifically for your configuration. They are laid out sequentially, including an exploded view of the entire display, and then a logical series of detailed steps to assemble the main structure and components. We encourage you to study the instructions **before** attempting to assemble your exhibit.

Each page reminds you to tighten the setscrews after disassembling your exhibit to prevent loss of the locks and setscrews (see below in RED). This is **VERY IMPORTANT**.

Cleaning and Packing Your Display

- 1) Use care when cleaning aluminum extrusion or acrylic inserts. Use only non-abrasive cleaners.
- 2) When cleaning laminate inserts or countertops, use mild cleansers and a soft material such as cotton.
- 3) Keep all display components away from extreme heat and long exposure to sunlight to avoid warping and fading.
- 4) Retain all packing material. It will make re-packing much easier and will reduce the likelihood of shipping damage.



The Tool

Most Visionary Designs exhibits can be assembled with the supplied Hex Key Tool. Occasionally, a flat head screwdriver may be required.



Typical Connection



Typical Connection (cont'd)

Most horizontal extrusion connections have a patented expandable lock. This lock inserts into the groove of an opposing extrusion. Tightening the lock with the Hex Key Tool expands the lock and creates a strong positive connection.

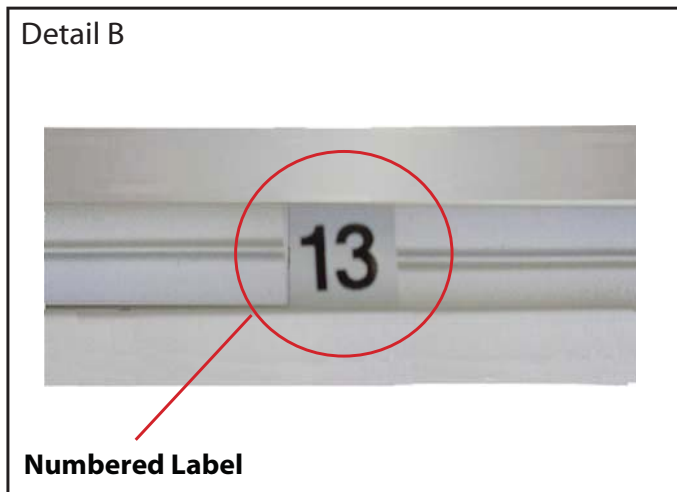

Numbered Label

Each extrusion contains a numbered label which corresponds with setup instructions. The label is located within a groove of the extrusion (when possible). With Visionary Designs the labels contain Black numbers unless otherwise specified.



Horizontal Inline Connection (remove only one setscrew)

Remove only (1) setscrew when disassembling. Replace setscrew in extrusion after assembling it. Before packing, replace setscrew in extrusion to avoid losing it.

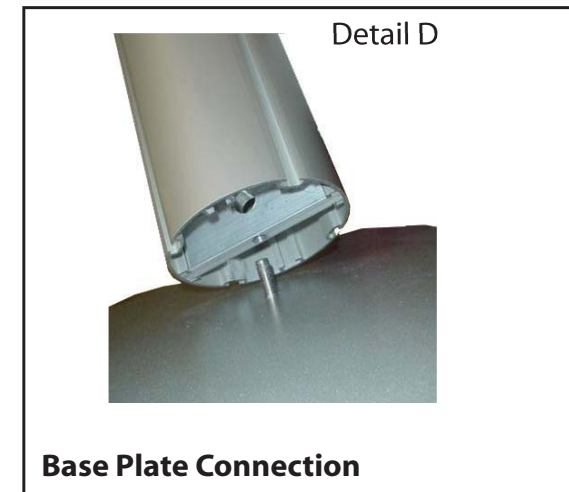

Base Plate Connection

Attach base plate to round or square vertical extrusion using the bolt provided. Be careful not to strip the threads.

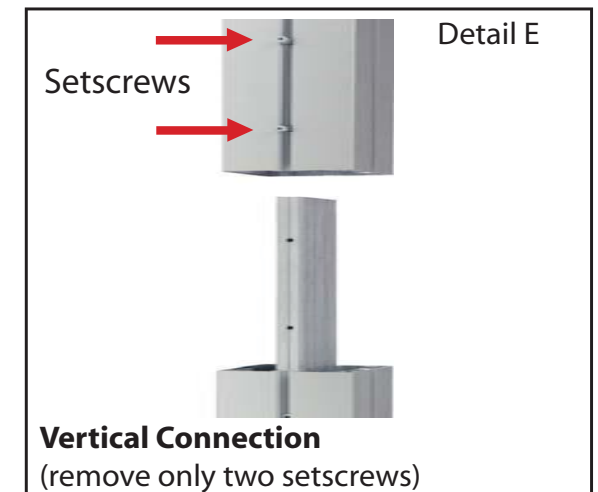

Vertical Connection
(remove only two setscrews)

When vertical extrusions are packed in portable cases rather than crates or tubs, they must be broken down into smaller sections which then require assembly.

Remove only (2) setscrews when disassembling. Replace setscrews in extrusion after assembling it. Before packing, replace setscrews in extrusion to avoid losing them.

WHEN DISASSEMBLING ALUMINUM EXTRUSION, TIGHTEN ALL SETSCREWS AND LOCKS TO PREVENT LOSS DURING SHIPPING

Item	Qty.	Description
1	1	45"R Curve Extrusion
2	1	45"R Curve Extrusion
3	1	45"R Curve Extrusion
4	1	45"R Curve Extrusion
5	1	45"R Curve Extrusion
6	1	45"R Curve Extrusion
7	1	37.85"h Vertical Extrusion
8	1	37.85"h Vertical Extrusion
9	1	42.625"h Vertical Extrusion
10	1	42.625"h Vertical Extrusion
11	1	37.85"h Vertical Extrusion
12	1	37.85"h Vertical Extrusion
13	1	18.3"w Horizontal Extrusion
14	1	21"w Horizontal Extrusion
15	1	21"w Horizontal Extrusion
16	1	18.3"w Horizontal Extrusion
17	1	18.3"w Horizontal Extrusion
18	1	21"w Horizontal Extrusion
19	1	21"w Horizontal Extrusion
20	1	18.3"w Horizontal Extrusion

Steps:

- 1) Connect extrusion pieces together [7 to 8, 9 to 10 and 11 to 12].
- 2) Lie curve pieces face down on floor to make complete circle, leave loose.
NOTE: Screw side must face upward.
- 3) Lie straight pieces and infills inside circle as shown.
- 4) Tighten locks to secure extrusions together.

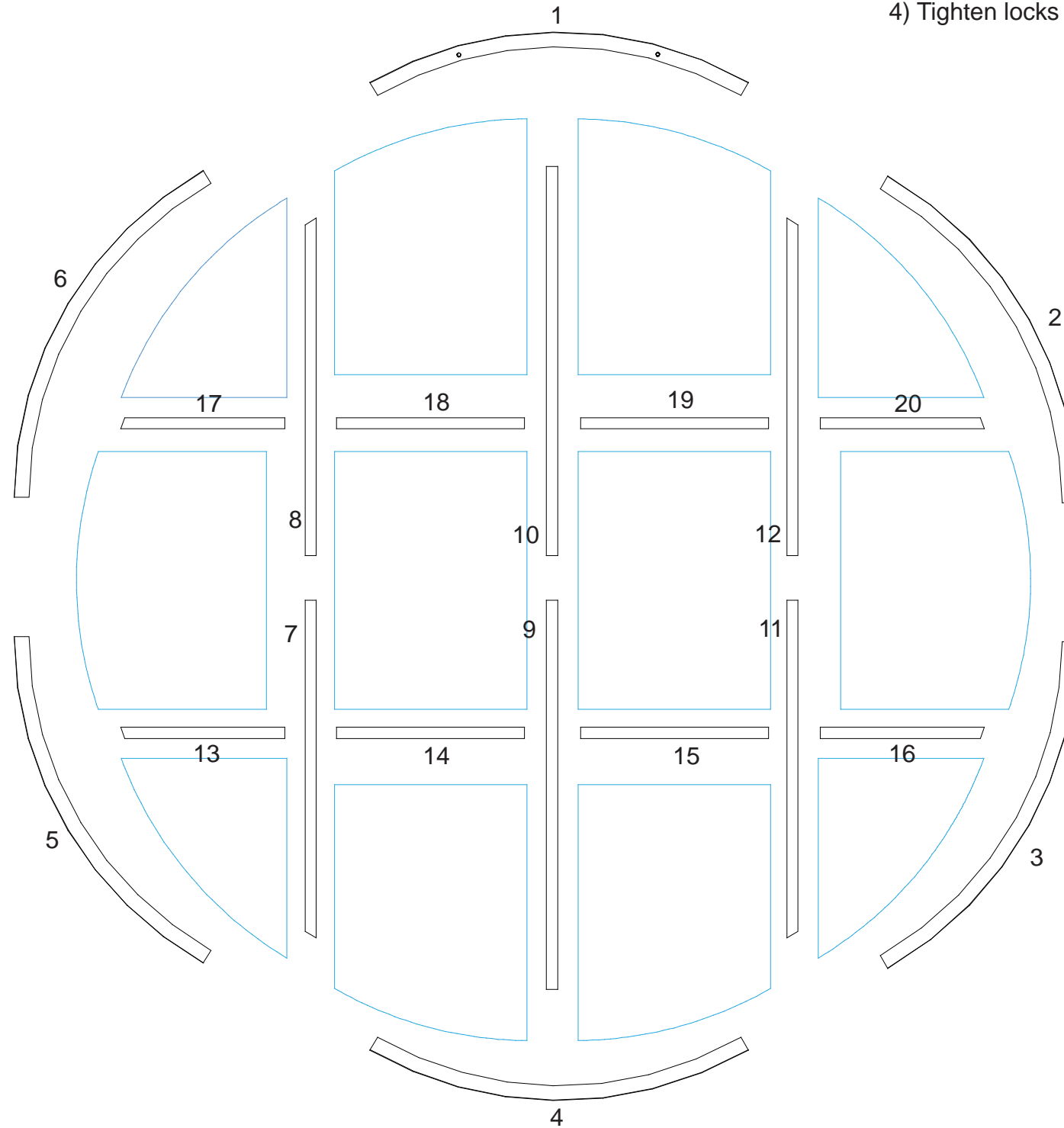

WHEN DISASSEMBLING ALUMINUM EXTRUSION, TIGHTEN ALL SETSCREWS AND LOCKS TO PREVENT LOSS DURING SHIPPING

866.652.2100

Item	Qty.	Description
21	2	13.26" w Horizontal Extrusion
22	2	13.26" w Horizontal Extrusion
23	2	13.26" w Horizontal Extrusion
24a/24b	2/2	40.19" Curved Horizontal Extrusion

Steps:

- 1) Attach horizontal extrusions [21, 22 and 23] to pill slots on back side of assembled circle section as shown.
- 2) Slide infills in between extrusions [21, 22 and 23].
- 3) Connect curved extrusions [24a to 24b] together.
- 4) Attach assembled curved extrusions [24a/24b] to horizontal extrusions [21, 22 and 23].

Backside of center section

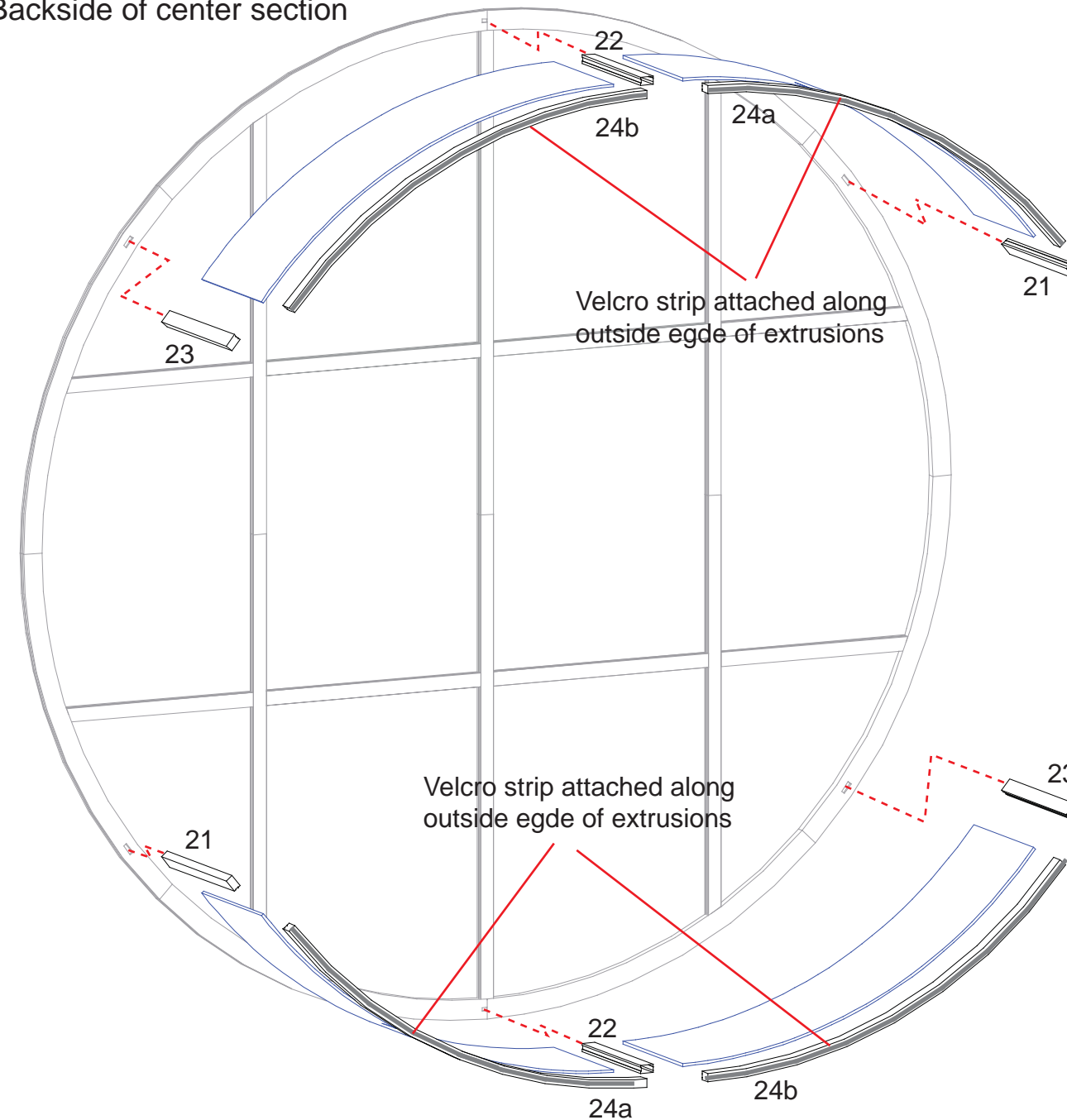

WHEN DISASSEMBLING ALUMINUM EXTRUSION, TIGHTEN ALL SETSCREWS AND LOCKS TO PREVENT LOSS DURING SHIPPING

866.652.2100

Item	Qty.	Description
25	2	42" h Lower Vertical Extrusion
26	2	42" h Upper Vertical Extrusion
27	2	22.4" w Horizontal Extrusion
28	2	8.75" w Horizontal Extrusion
29	2	22.4" w Horizontal Extrusion
30	2	Base Plate

Steps:

- 1) Attach vertical extrusions [25] to base plates [30].
- 2) Attach upper vertical extrusions [26] to lower extrusions [25].
- 3) Connect horizontal extrusions [27, 28 and 29] to vertical assemblies [25/26], placing infills between extrusions.
 - Note:* - Attach lower horizontal to vertical [25] and set on stopper.
 - Set lower infill on lower horizontal.
 - Attach middle horizontal to vertical extrusion and set atop infill.
 - Repeat steps for upper infill and upper horizontal.
- 4) Connect assembled circular center section between horizontal extrusions.

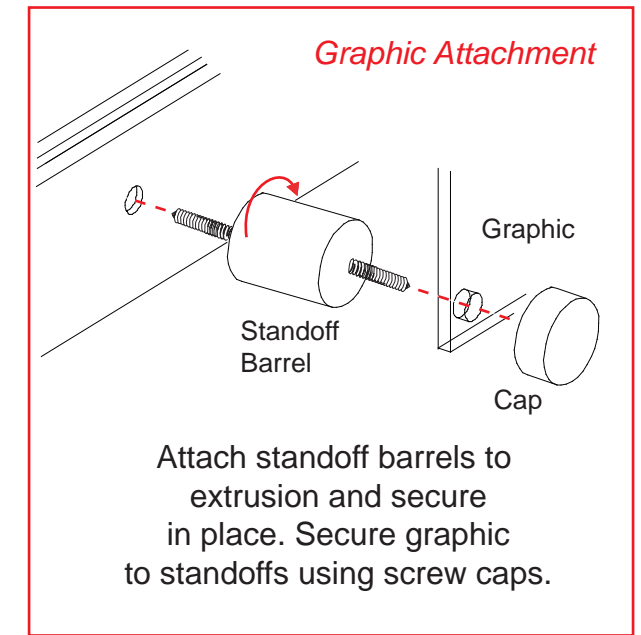
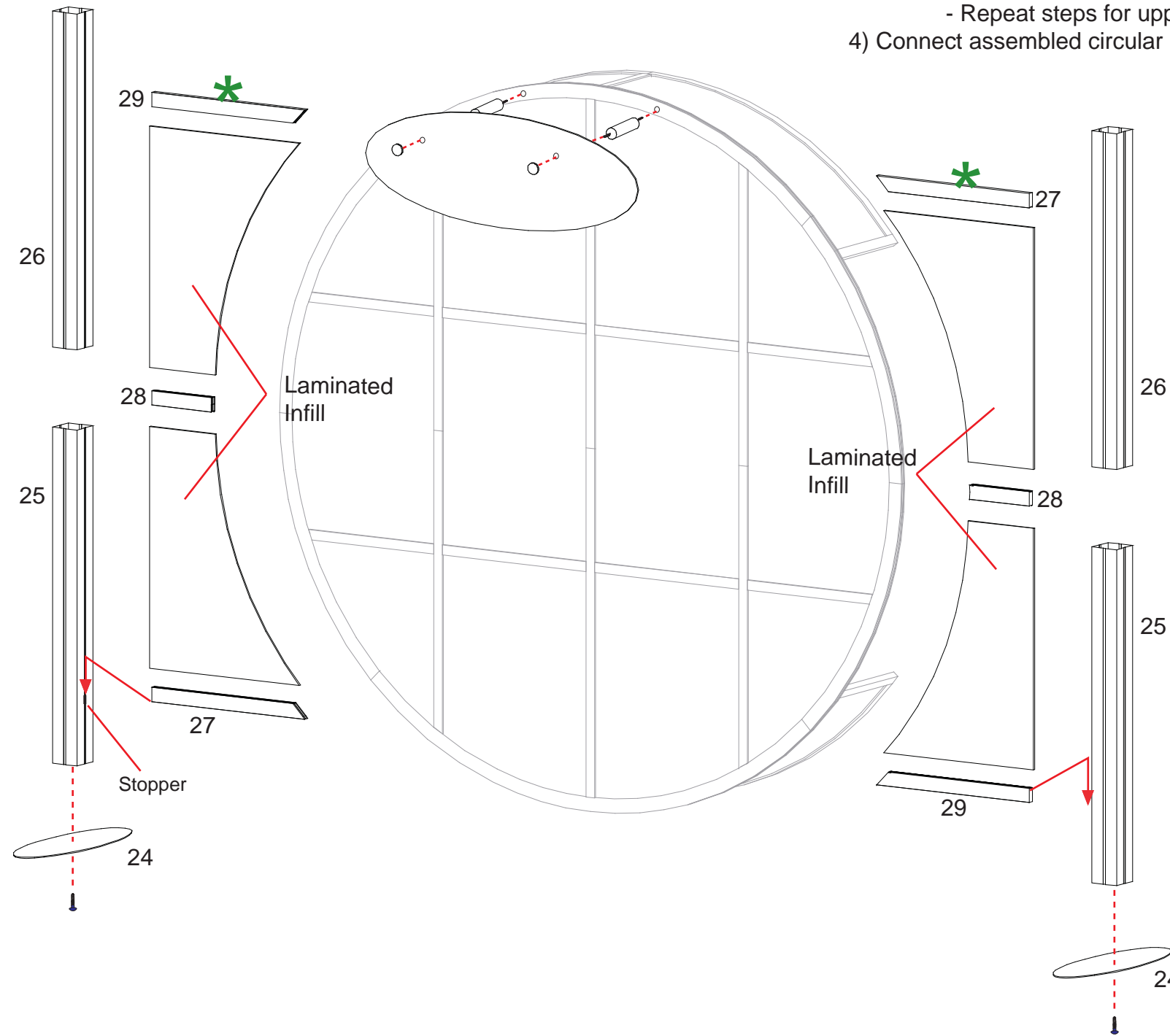
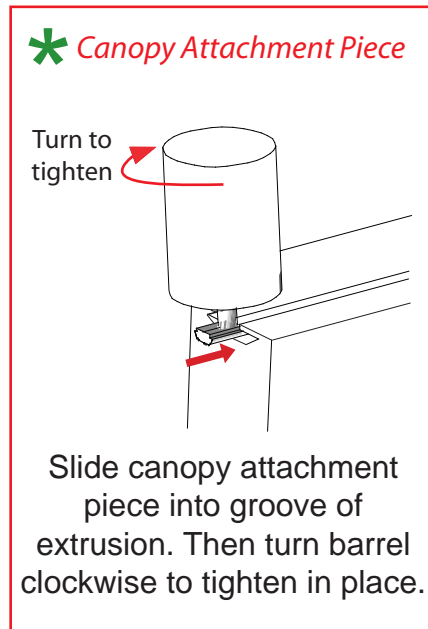

WHEN DISASSEMBLING ALUMINUM EXTRUSION, TIGHTEN ALL SETSCREWS AND LOCKS TO PREVENT LOSS DURING SHIPPING



Steps:

- 1) Connect canopy pieces together as shown.
- 2) Apply pillow case graphic to assembled canopy.

Using Your Setup Instructions

The Aero Overhead Sign Setup Instructions are created specifically for your configuration. They include an exploded view of the frame which is sequentially numbered. We encourage you to study the instructions before attempting to assemble your exhibit.

Connections are kept very simple: no tools. Everything assembles with push-button connectors and pre-connected horizontal sections.

Cleaning and Packing Your Display

- 1) Use care when cleaning aluminum extrusion or acrylic inserts. Use only non-abrasive cleaners.
- 2) Retain all packing material. It will make re-packing much easier and will reduce the likelihood of shipping damage.

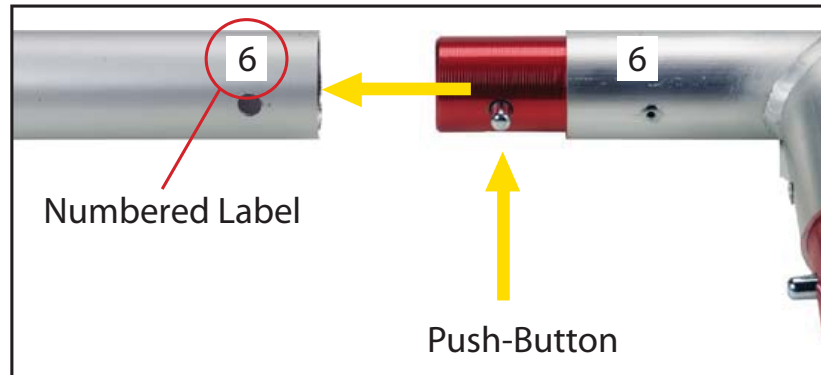
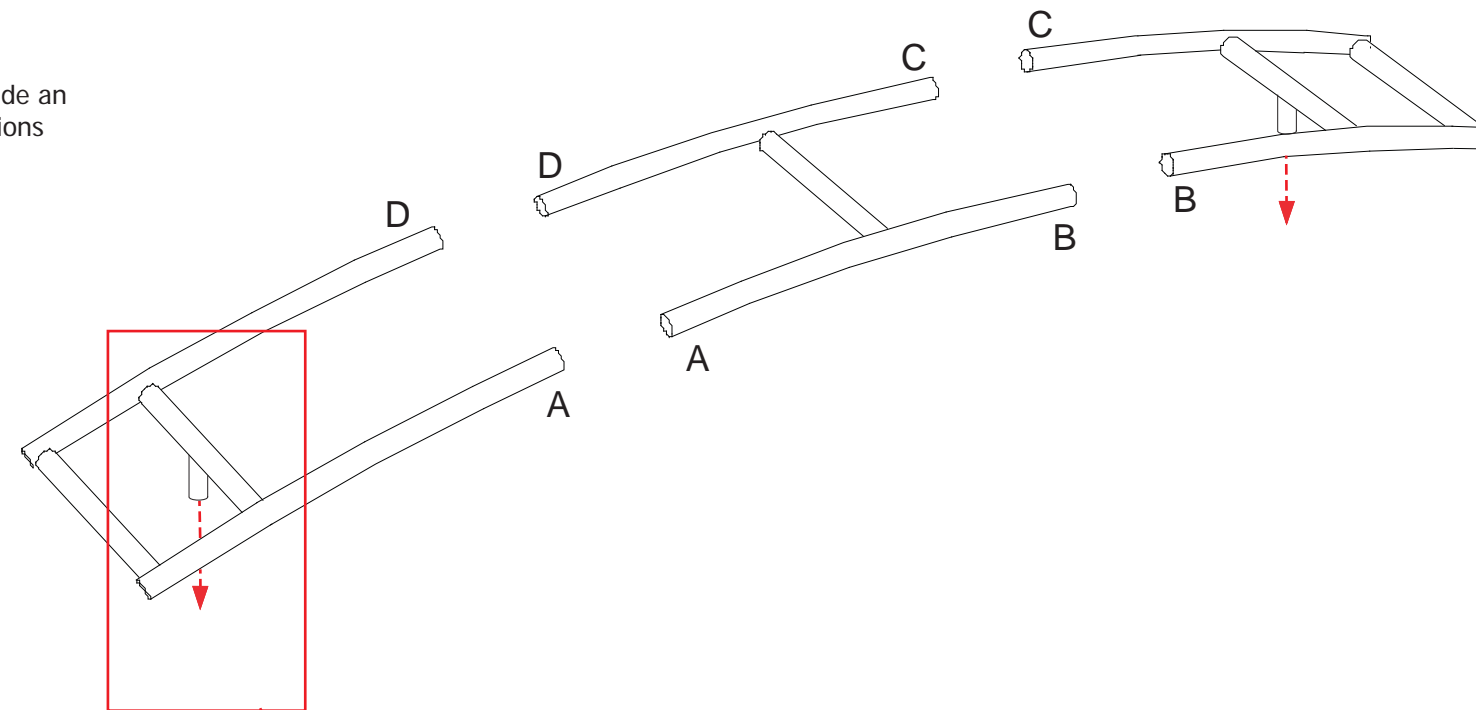

Connections are made by holding the button down and sliding the red tube into opposing tube until the connection is made. To disassemble push button and pull or twist extrusions apart.

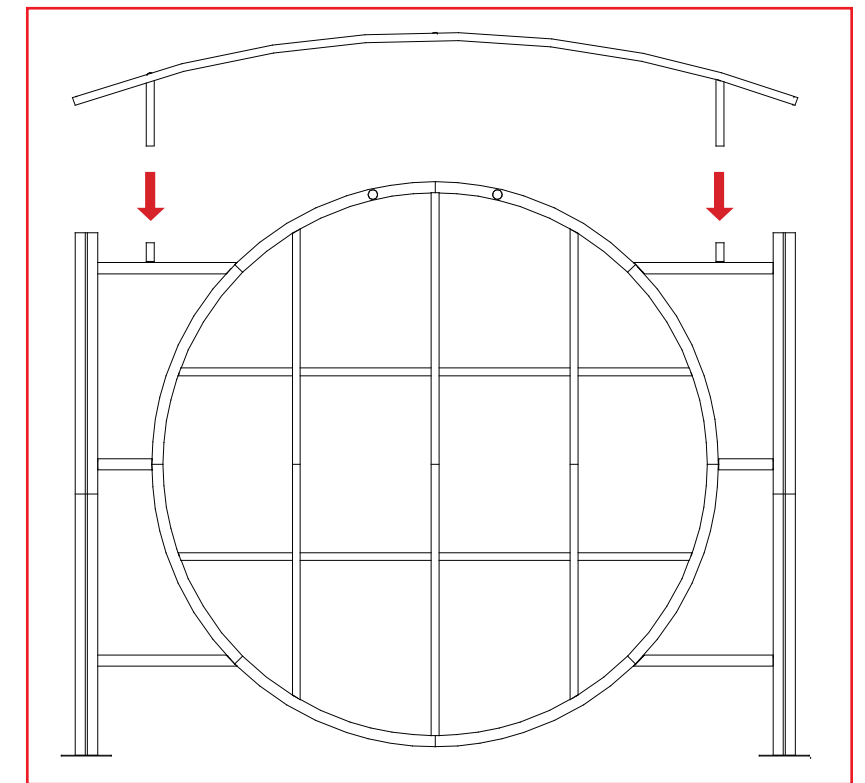
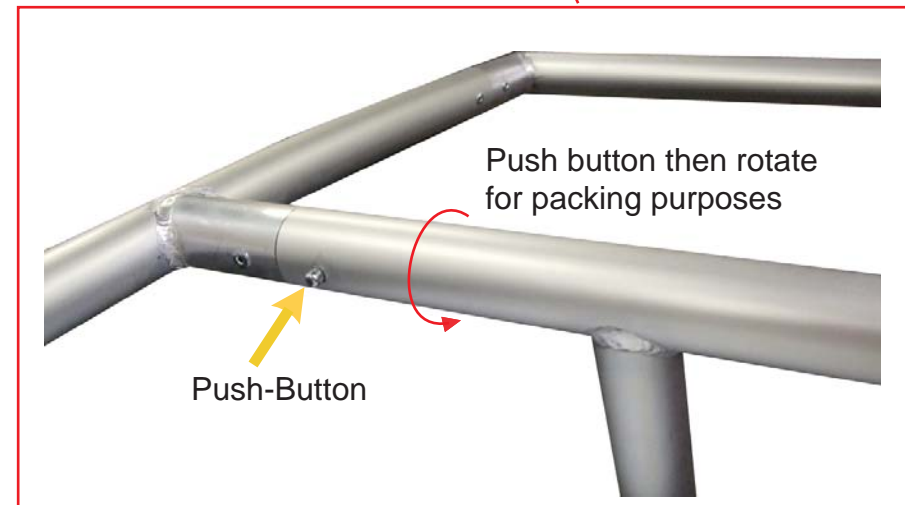
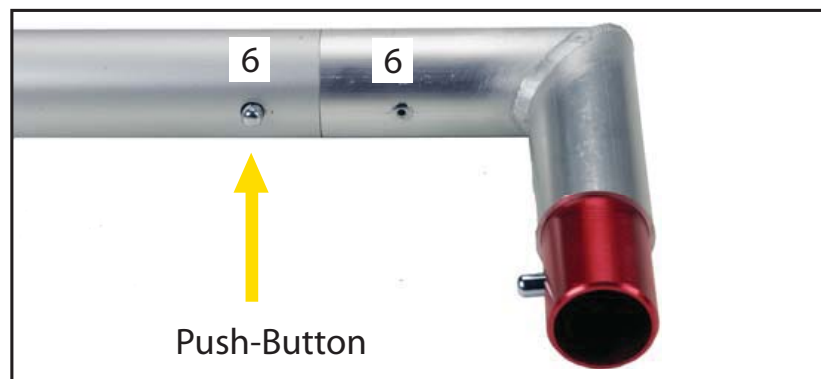

WHEN DISASSEMBLING ALUMINUM EXTRUSION, TIGHTEN ALL SETSCREWS AND LOCKS TO PREVENT LOSS DURING SHIPPING

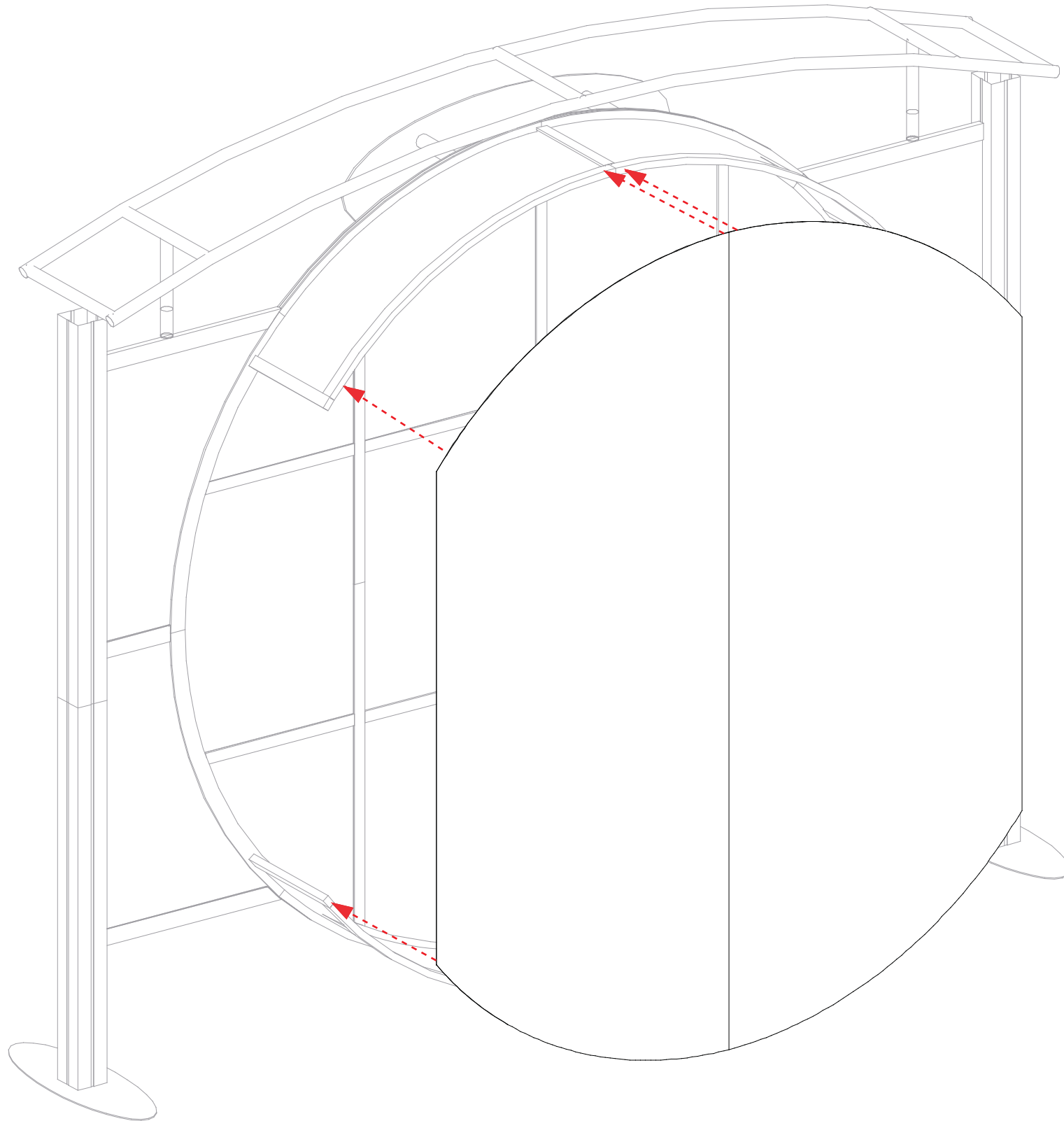

Steps:

- 1) Velcro fluorescent lights to light reflector panels as shown.
- 2) Velcro reflector panels to back of assembled backwall.

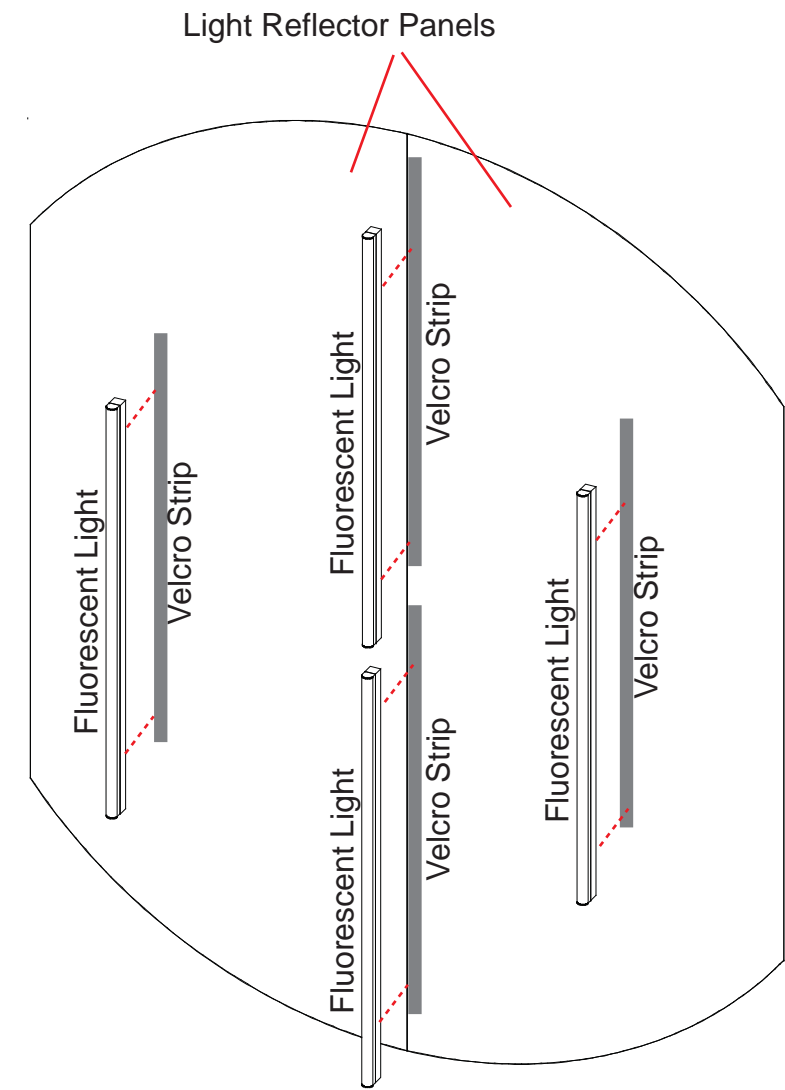

WHEN DISASSEMBLING ALUMINUM EXTRUSION, TIGHTEN ALL SETSCREWS AND LOCKS TO PREVENT LOSS DURING SHIPPING

Top View of each Level

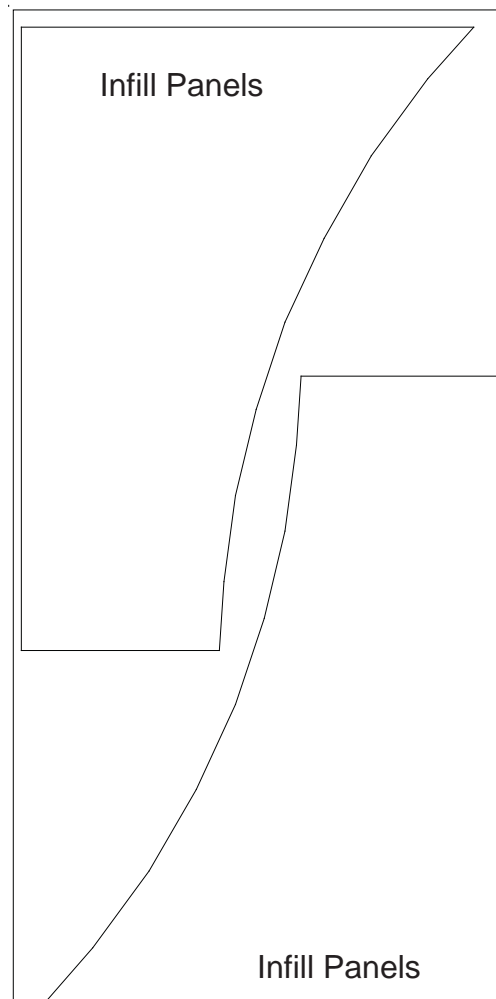

Level 1

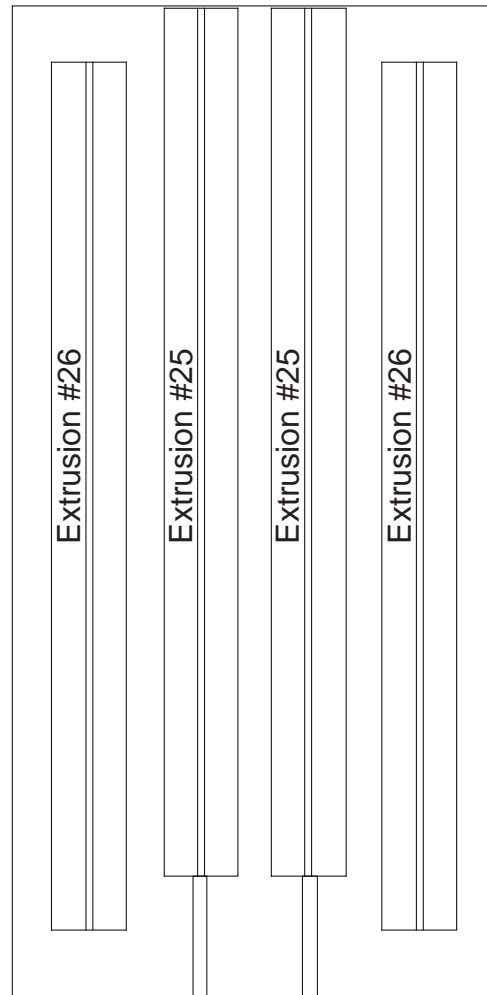

Level 2

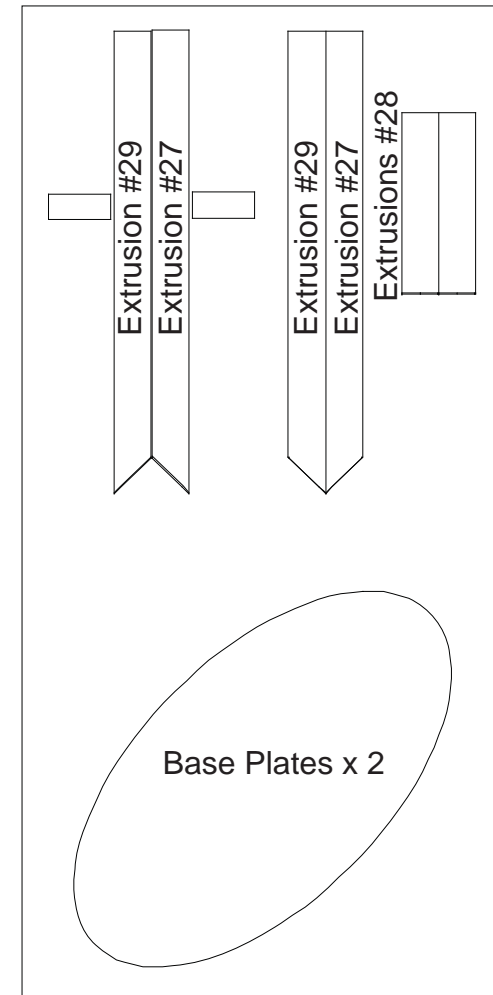

Level 3

Additional Items
- Setup Hardware

WHEN DISASSEMBLING ALUMINUM EXTRUSION, TIGHTEN ALL SETSCREWS AND LOCKS TO PREVENT LOSS DURING SHIPPING

Top View of each Level

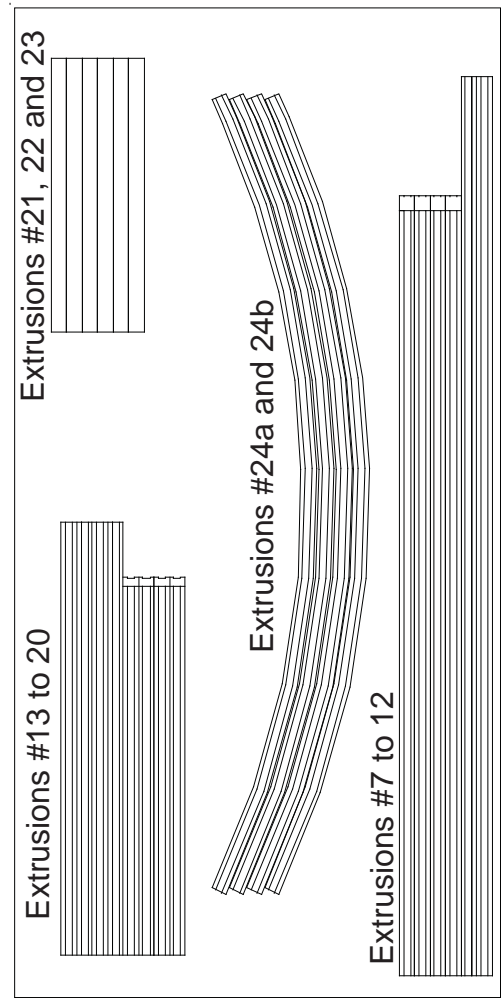

Level 1

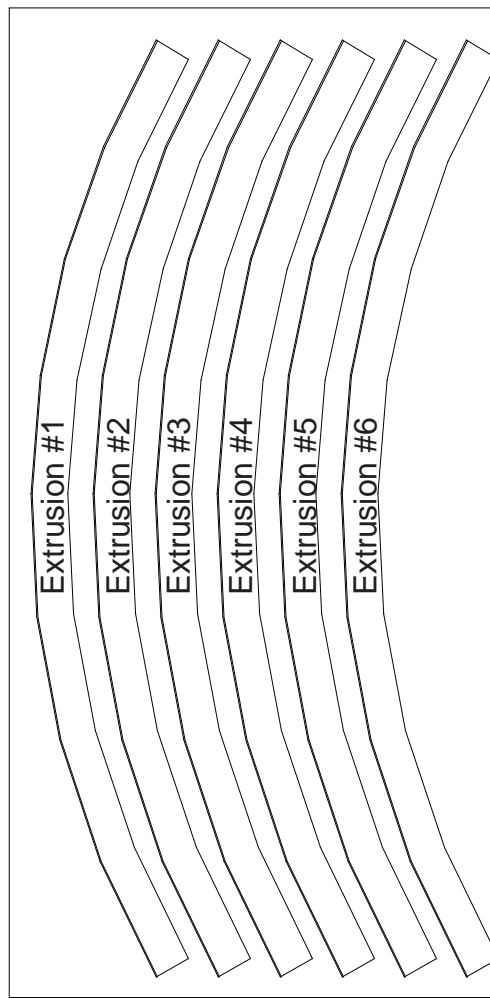

Level 2

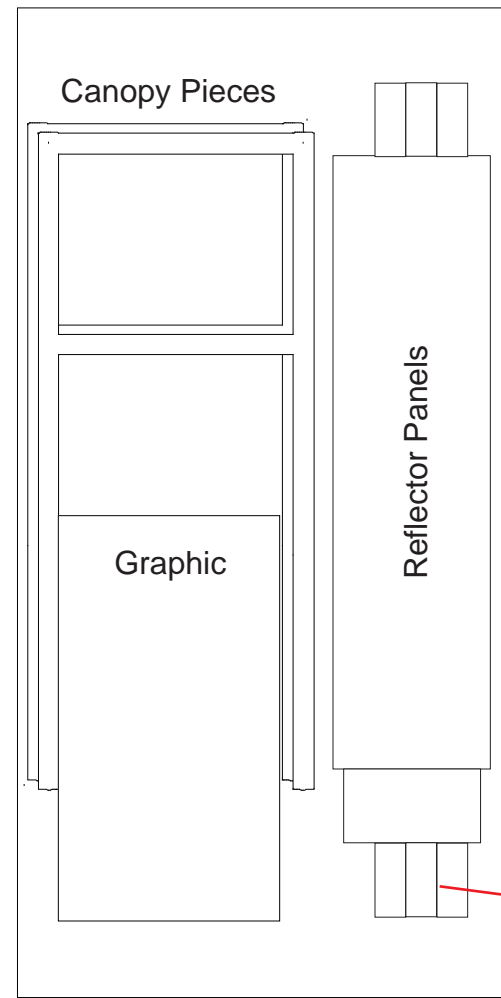

Level 3

WHEN DISASSEMBLING ALUMINUM EXTRUSION, TIGHTEN ALL SETSCREWS AND LOCKS TO PREVENT LOSS DURING SHIPPING