

WHEN DISASSEMBLING ALUMINUM EXTRUSION, TIGHTEN ALL SETSCREWS AND LOCKS TO PREVENT LOSS DURING SHIPPING

visionary™ DESIGNS

Using Your Setup Instructions

The Visionary Designs Setup Instructions are created specifically for your configuration. They are laid out sequentially, including an exploded view of the entire display, and then a logical series of detailed steps to assemble the main structure and components. We encourage you to study the instructions **before** attempting to assemble your exhibit.

Each page reminds you to tighten the setscrews after disassembling your exhibit to prevent loss of the locks and setscrews (see below in RED). This is **VERY IMPORTANT**.

Cleaning and Packing Your Display

- 1) Use care when cleaning aluminum extrusion or acrylic inserts. Use only non-abrasive cleaners.
- 2) When cleaning laminate inserts or countertops, use mild cleansers and a soft material such as cotton.
- 3) Keep all display components away from extreme heat and long exposure to sunlight to avoid warping and fading.
- 4) Retain all packing material. It will make re-packing much easier and will reduce the likelihood of shipping damage.



The Tool

Most Visionary Designs exhibits can be assembled with the supplied Hex Key Tool. Occasionally, a flat head screwdriver may be required.



Typical Connection

Most horizontal extrusion connections have a patented expandable lock. This lock inserts into the groove of an opposing extrusion. Tightening the lock with the Hex Key Tool expands the lock and creates a strong positive connection.



Typical Connection (cont'd)



Detail B

Numbered Label

Each extrusion contains a numbered label which corresponds with setup instructions. The label is located within a groove of the extrusion (when possible). With Visionary Designs the labels contain Black numbers unless otherwise specified.



Detail C

Horizontal Inline Connection (remove only one setscrew)

Remove only (1) setscrew when disassembling. Replace setscrew in extrusion after assembling it. Before packing, replace setscrew in extrusion to avoid losing it.

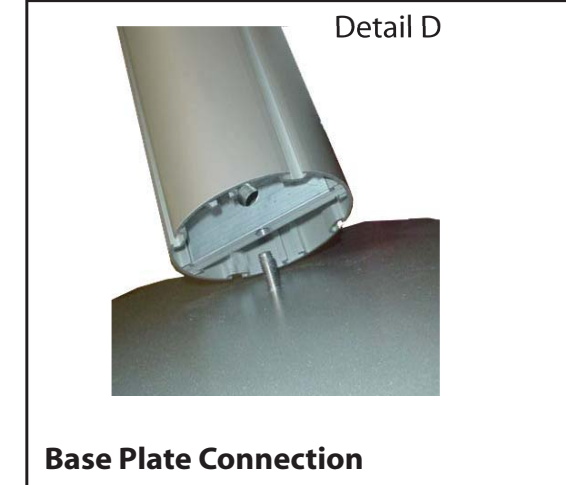

Detail D

Base Plate Connection

Attach base plate to round or square vertical extrusion using the bolt provided. Be careful not to strip the threads.

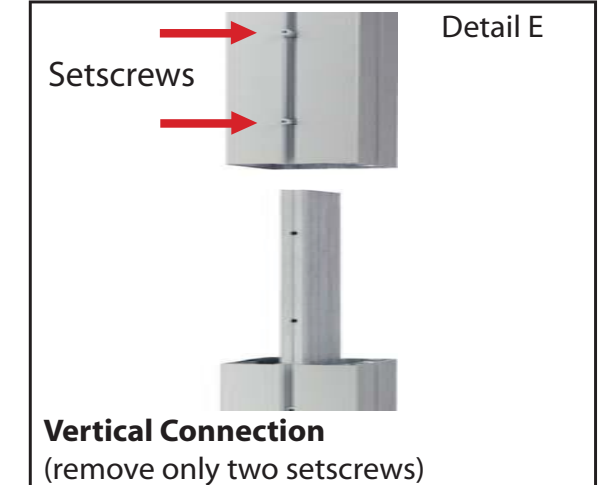

Detail E

Vertical Connection
(remove only two setscrews)

When vertical extrusions are packed in portable cases rather than crates or tubs, they must be broken down into smaller sections which then require assembly.

Remove only (2) setscrews when disassembling. Replace setscrews in extrusion after assembling it. Before packing, replace setscrews in extrusion to avoid losing them.

WHEN DISASSEMBLING ALUMINUM EXTRUSION, TIGHTEN ALL SETSCREWS AND LOCKS TO PREVENT LOSS DURING SHIPPING

Item	Qty.	Description
1	1	Oval Base Plates
2	1	84" Vertical Extrusion w/ Canopy Attachment
3	1	84" Vertical Extrusion
4	1	84" Vertical Extrusion w/ Canopy Attachment
5A/5B	1/1	28" Horizontal Extrusion
6A/6B	1/1	52" Horizontal Extrusion

Steps

- 1) Attach vertical extrusion [4] to the oval base plate [1].
- 2) Attach horizontal extrusions [5A, 5B, 6A and 6B] between vertical extrusions [2, 3 and 4] as shown.
- 3) Apply graphics to assembled backwall.

866.652.2100

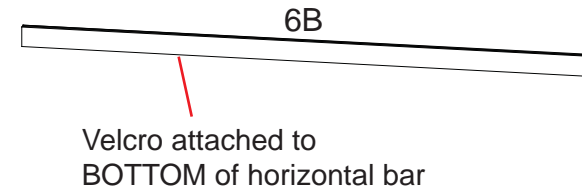
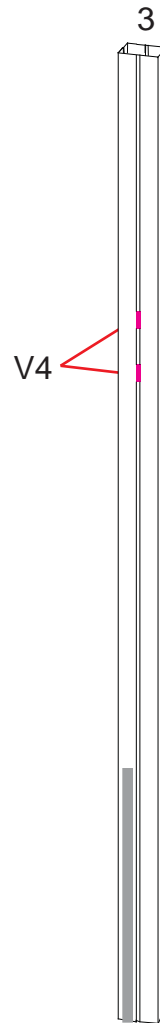
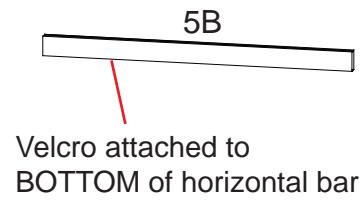
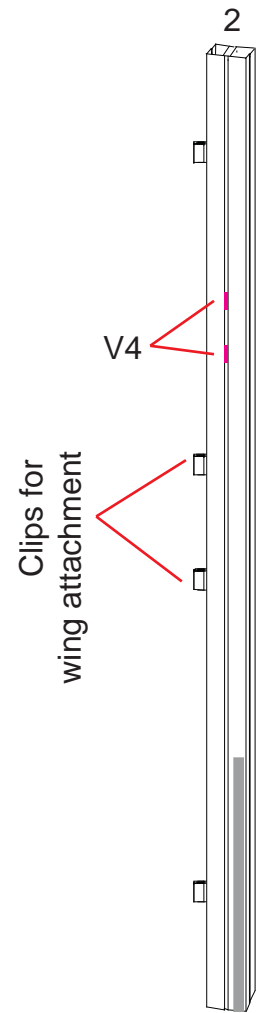
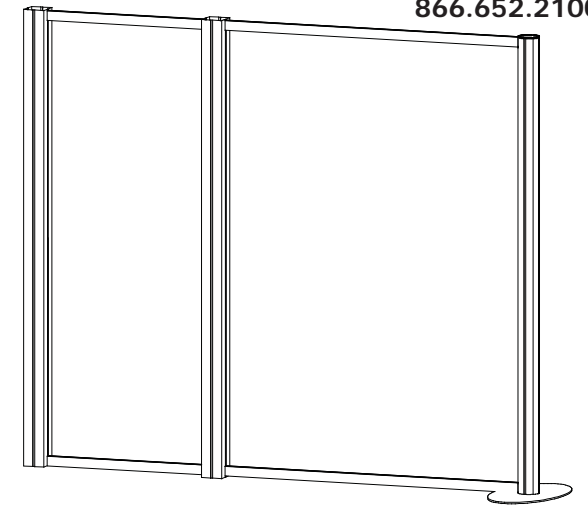

Note: Attaching Graphics

Attach Backwall Graphics to Velcro by wrapping the Graphic over the Top of the Upper Horizontals and under the Bottom of the Lower Horizontals

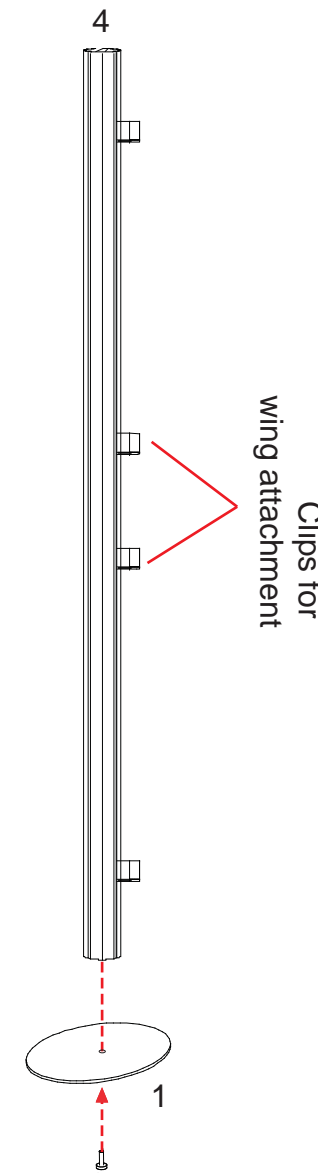
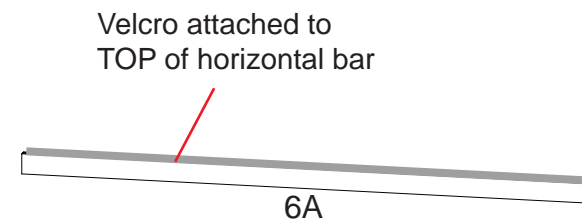
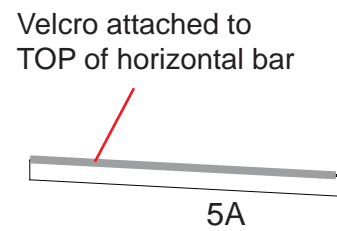

WHEN DISASSEMBLING ALUMINUM EXTRUSION, TIGHTEN ALL SETSCREWS AND LOCKS TO PREVENT LOSS DURING SHIPPING

866.652.2100

Item	Qty	Description
7	1	38" h Vertical Extrusion w/ Door Stop
8	1	38" h Vertical Extrusion w/ Door Hinge
9	4	12.5" w Horizontal Extrusion
10	2	Curved Horizontal Extrusion
4		Internal Shelf Support

Steps

- 1) Attach lower horizontal extrusions between vertical extrusions where indicated.
- 2) Insert infill panels and attach door.
- 3) Attach the upper horizontal extrusions atop infills and door.
- 4) Velcro shelf supports to inside of assembled base.
- 5) Set internal shelf atop shelf supports.
- 6) Place counter top atop assembled base.

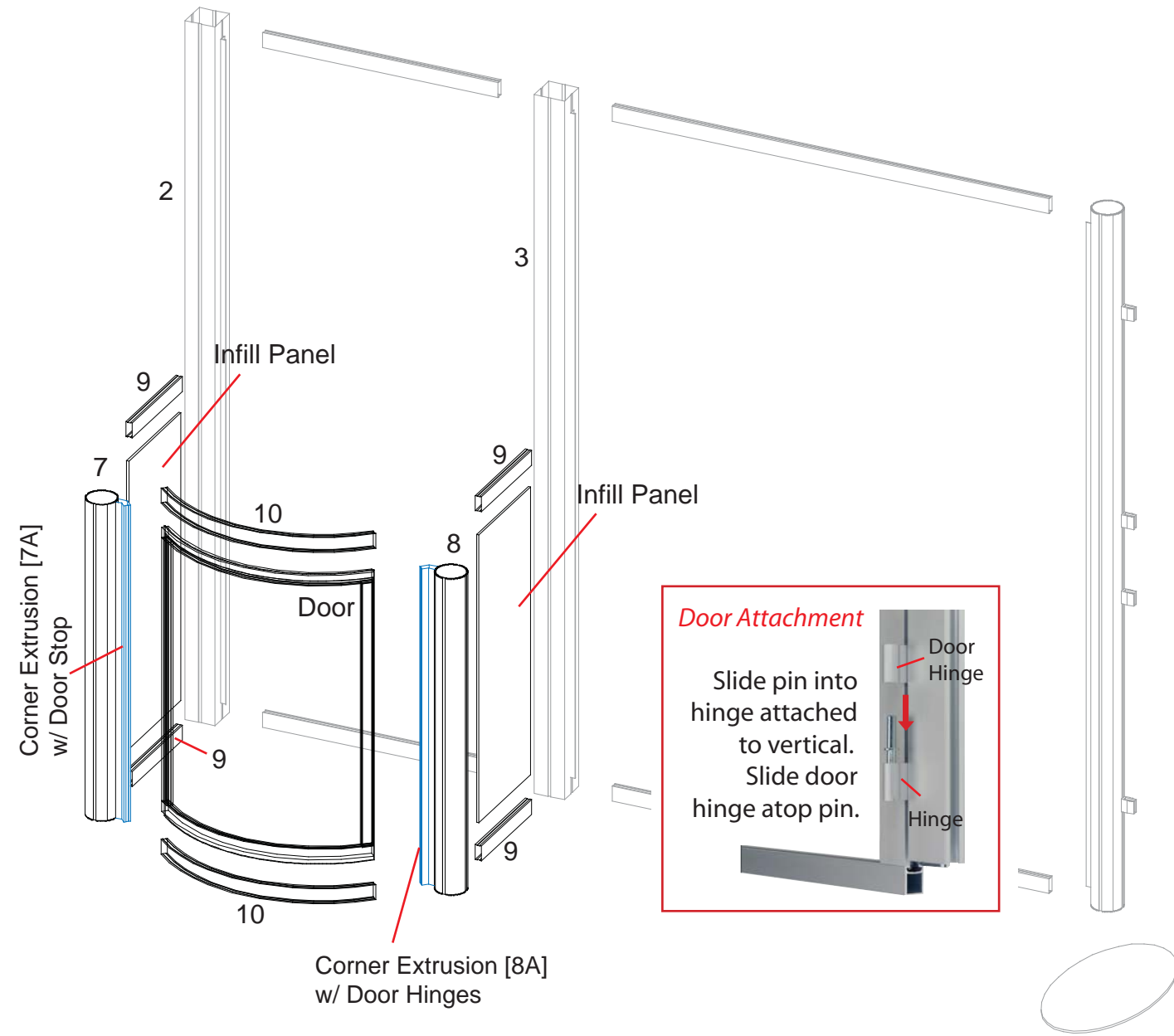

Note: Front section [7, 8, 10 and door] must stay assembled when shipping in crate.

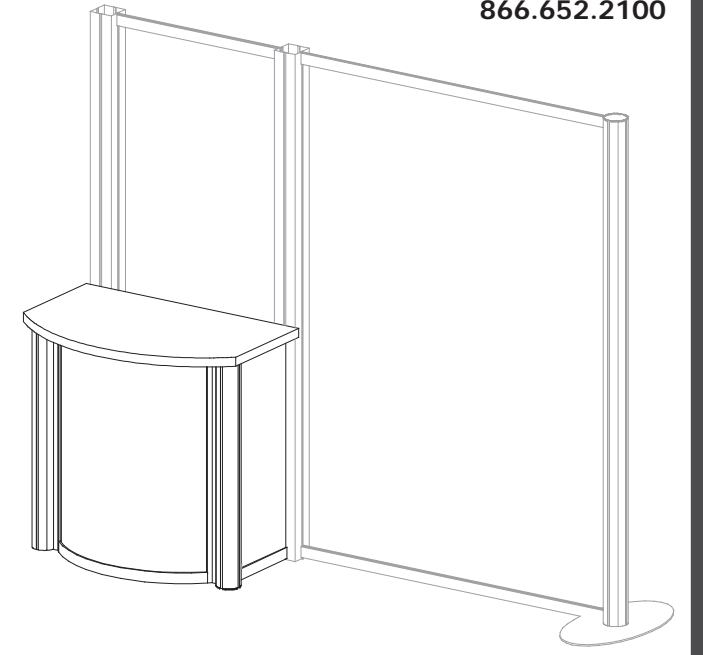
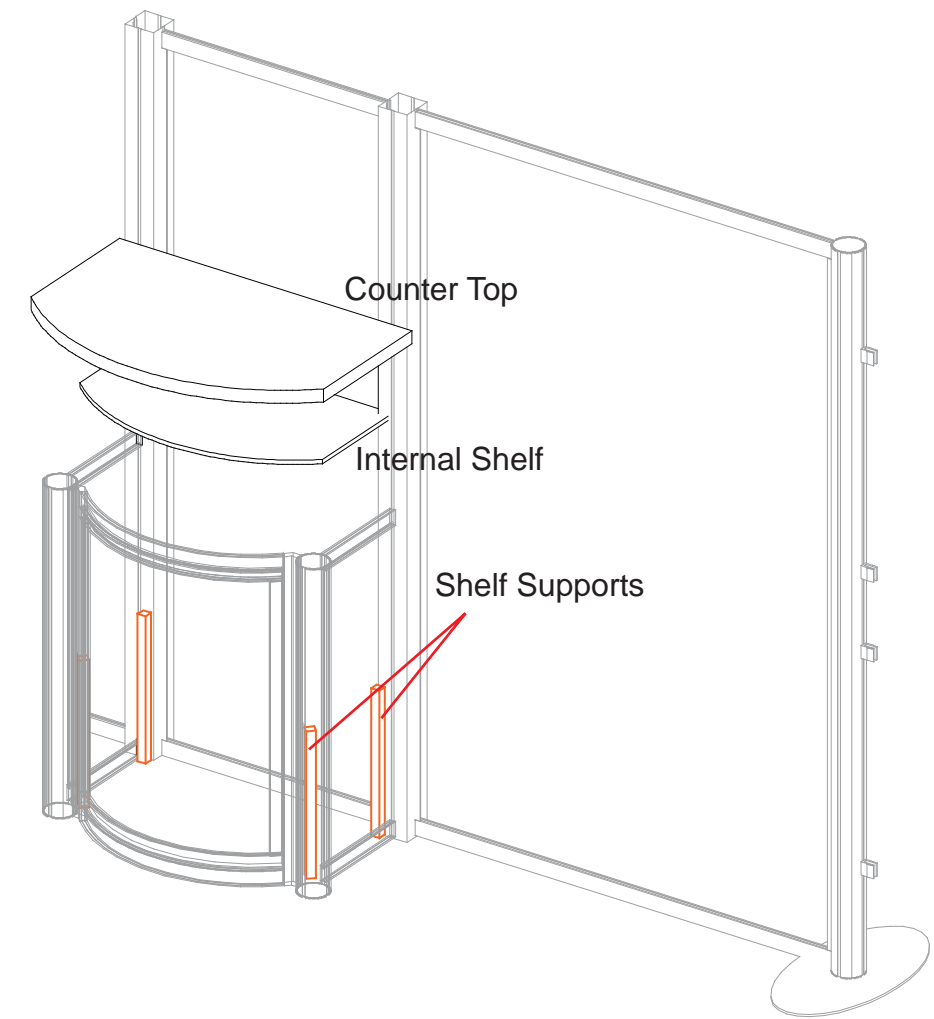

WHEN DISASSEMBLING ALUMINUM EXTRUSION, TIGHTEN ALL SETSCREWS AND LOCKS TO PREVENT LOSS DURING SHIPPING

866.652.2100

Item	Qty.	Description
11	1	5.862"w Vertical Extrusion
12	1	5.862"w Vertical Extrusion
13	1	80.638"w Formed Horizontal Extrusion
14	1	78"w Horizontal Extrusion

Steps

- 1) Connect vertical extrusions [11 and 12] to left and right side of horizontal extrusion [14].
- 2) Attach formed horizontal extrusion [13] atop vertical extrusions [11 and 12].
- 3) Attach header to assembled backwall as shown.
- 4) Attach Sign using standoff barrels and caps.
- 5) Attach wings using A10 clamps as shown.

Note: Attaching Graphics
Attach Header Graphic to Back of assembled header frame.

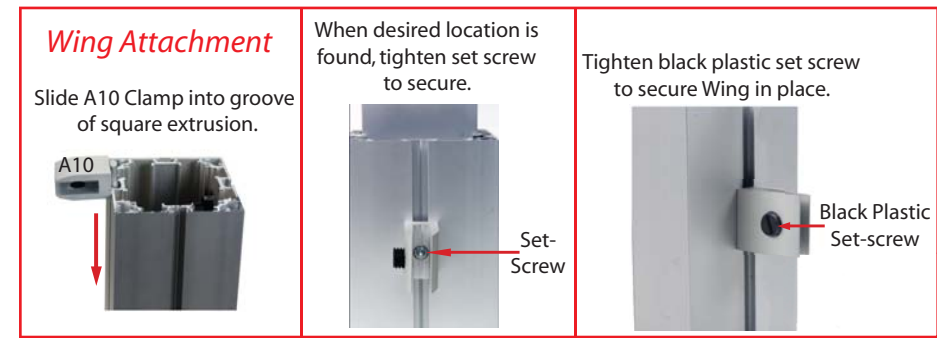
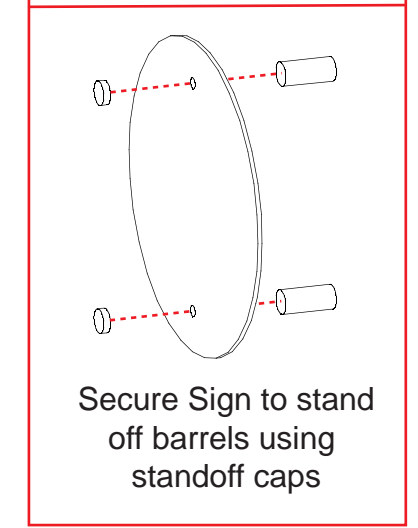
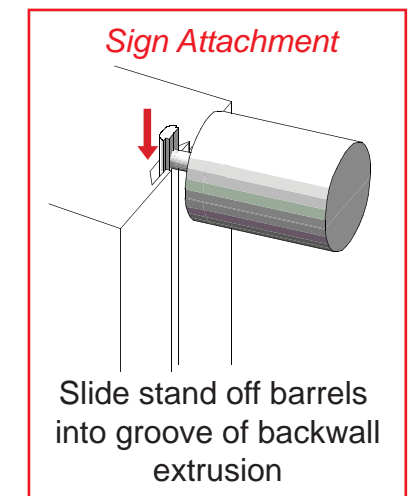
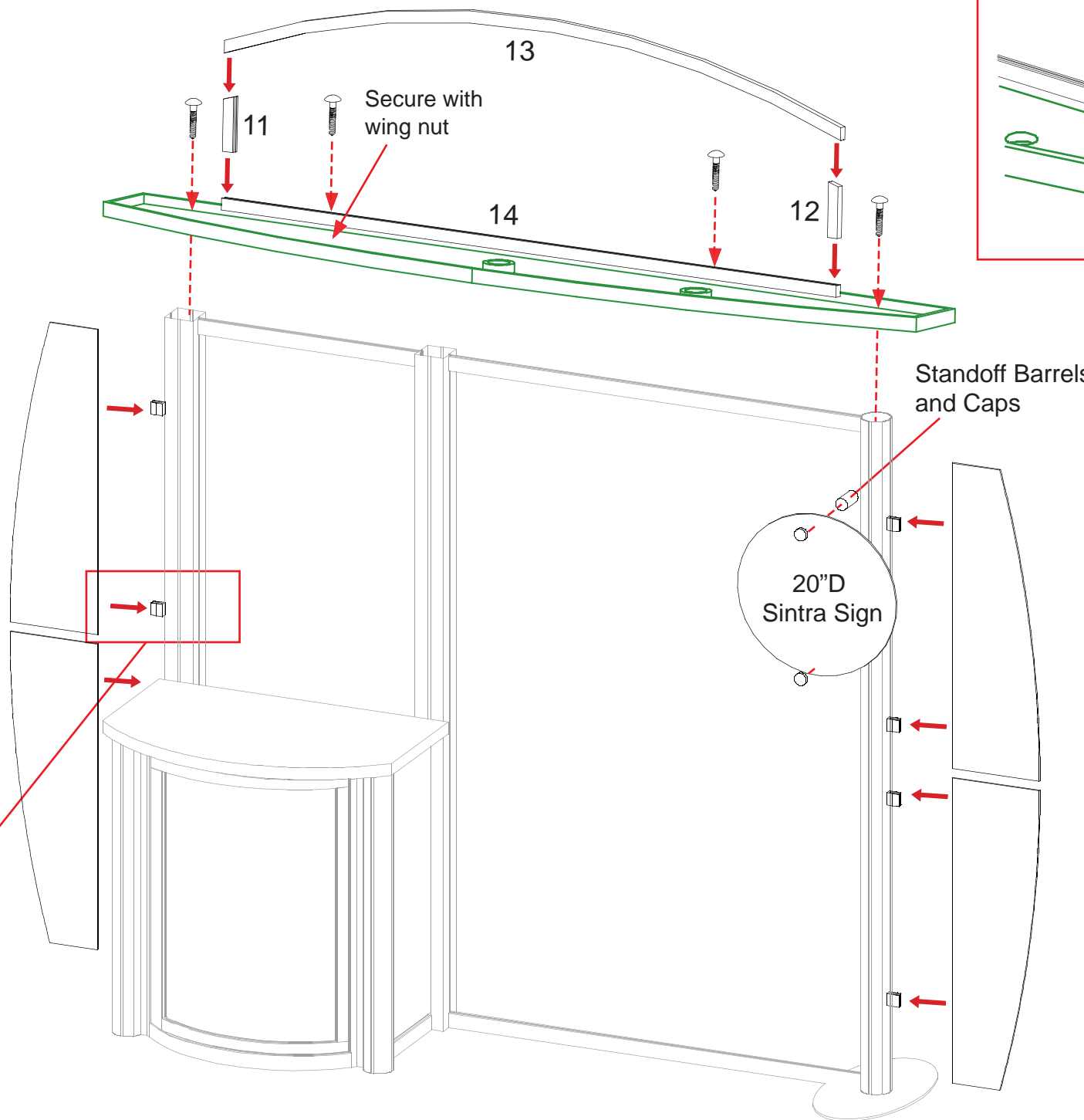
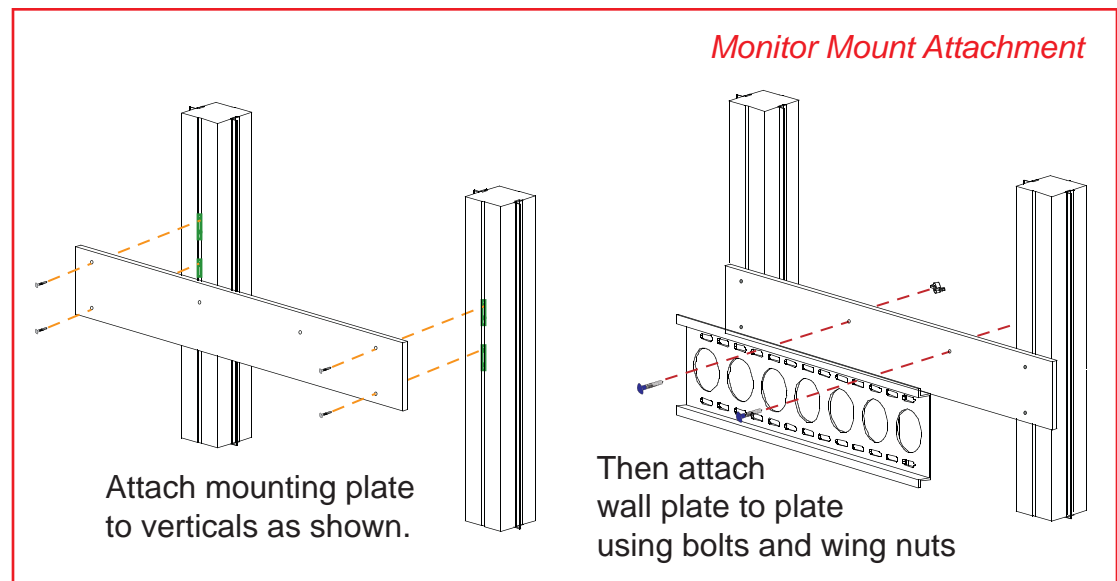
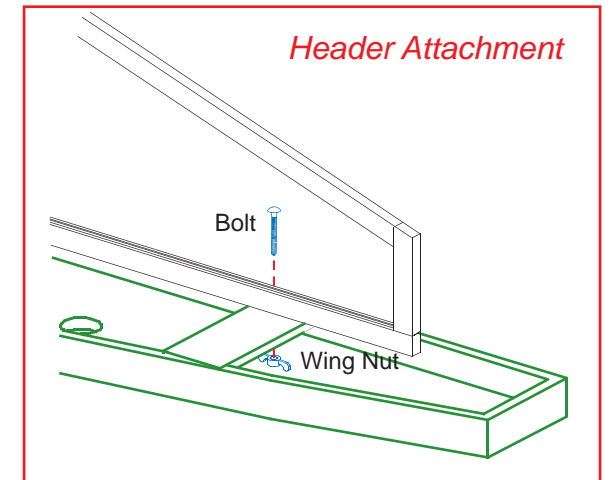

WHEN DISASSEMBLING ALUMINUM EXTRUSION, TIGHTEN ALL SETSCREWS AND LOCKS TO PREVENT LOSS DURING SHIPPING

866.652.2100

Setup Instructions:

- A) Use standoff screws to secure the front panel with door and back panel of the pedestal to the side panels.
- B) After assembling front, back, and side panels, slide floor into the bottom of the pedestal. The floor will sit on pins on the inside of the side panels.
- C) After floor is in place, use velcro attachments to install shelf.

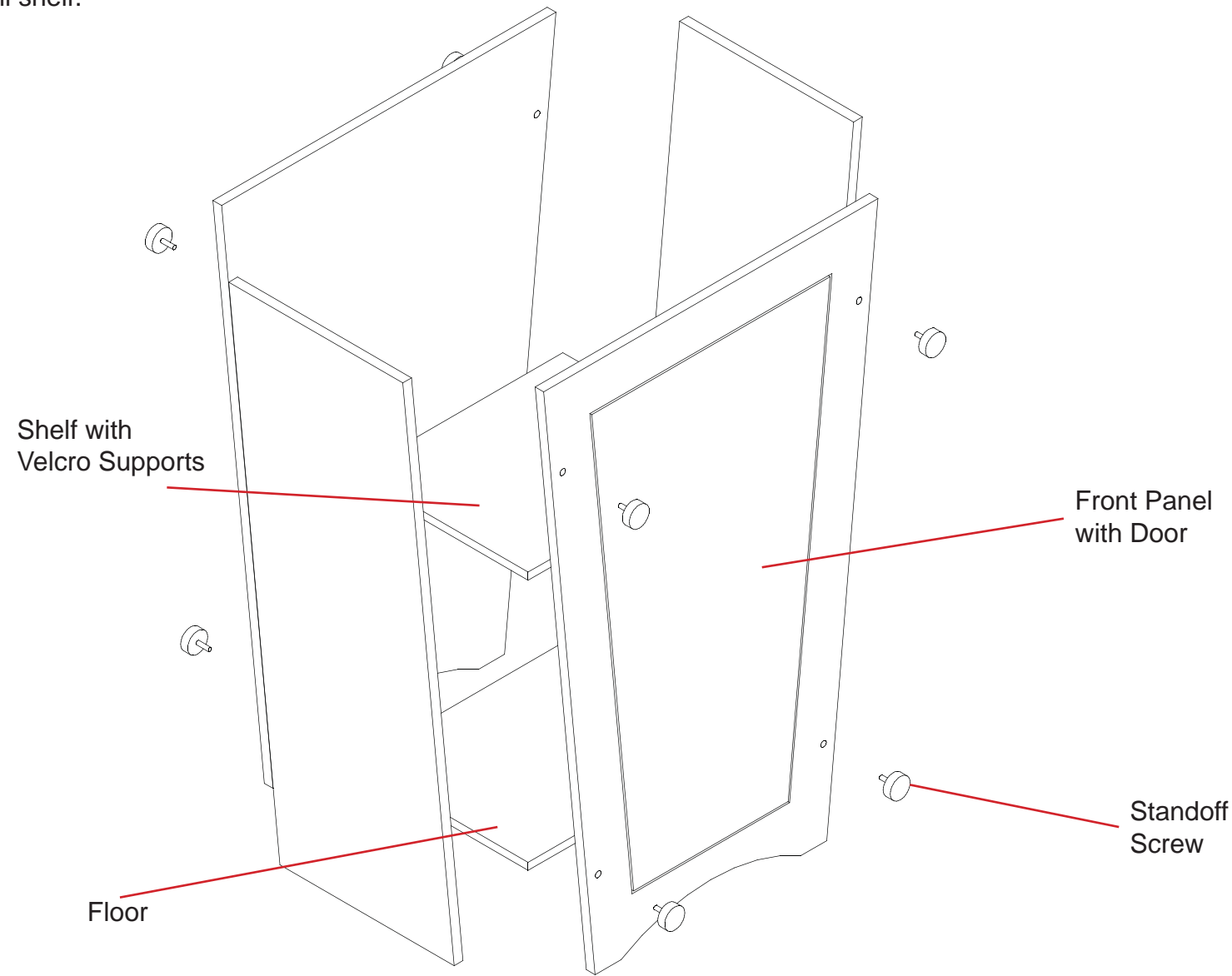
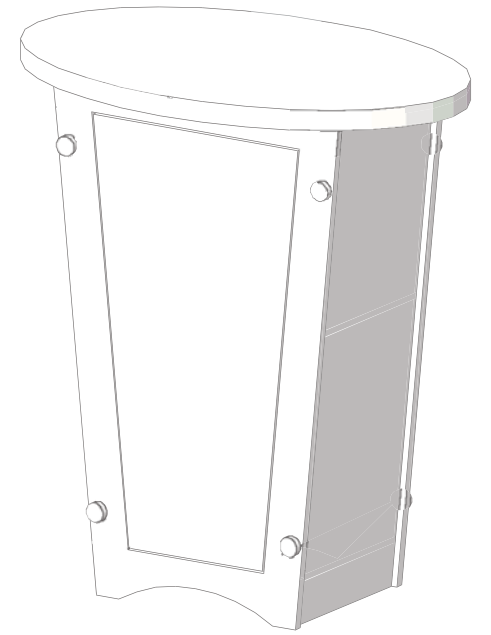

Attach the oval counter top to the pedestal base.

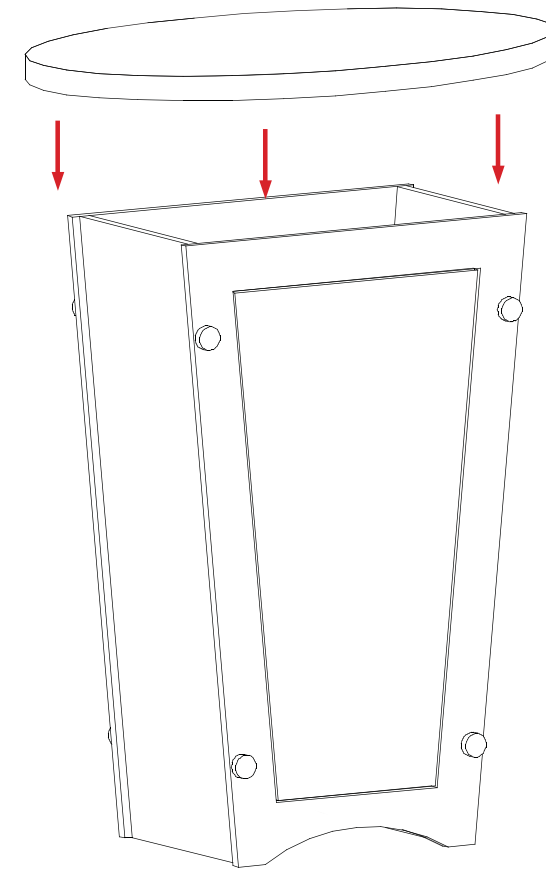

WHEN DISASSEMBLING ALUMINUM EXTRUSION, TIGHTEN ALL SETSCREWS AND LOCKS TO PREVENT LOSS DURING SHIPPING

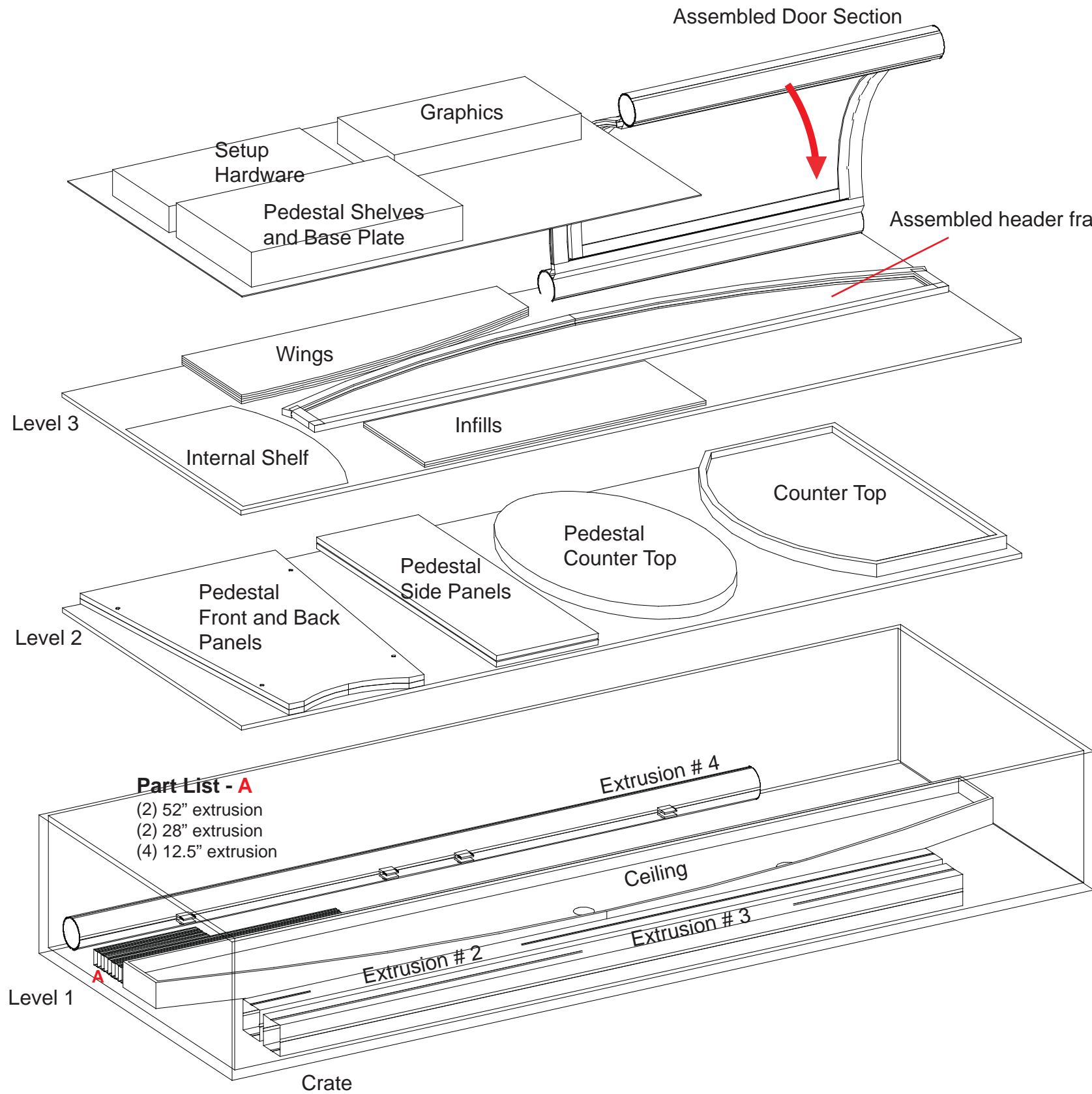

Level 3



Level 2



Level 1

WHEN DISASSEMBLING ALUMINUM EXTRUSION, TIGHTEN ALL SETSCREWS AND LOCKS TO PREVENT LOSS DURING SHIPPING