

WHEN DISASSEMBLING ALUMINUM EXTRUSION, TIGHTEN ALL SETSCREWS AND LOCKS TO PREVENT LOSS DURING SHIPPING

visionary™ IDESIGNS

Using Your Setup Instructions

The Visionary Designs Setup Instructions are created specifically for your configuration. They are laid out sequentially, including an exploded view of the entire display, and then a logical series of detailed steps to assemble the main structure and components. We encourage you to study the instructions **before** attempting to assemble your exhibit.

Each page reminds you to tighten the setscrews after disassembling your exhibit to prevent loss of the locks and setscrews (see below in RED). This is **VERY IMPORTANT**.

Cleaning and Packing Your Display

- 1) Use care when cleaning aluminum extrusion or acrylic inserts. Use only non-abrasive cleaners.
- 2) When cleaning laminate inserts or countertops, use mild cleansers and a soft material such as cotton.
- 3) Keep all display components away from extreme heat and long exposure to sunlight to avoid warping and fading.
- 4) Retain all packing material. It will make re-packing much easier and will reduce the likelihood of shipping damage.



The Tool

Most Visionary Designs exhibits can be assembled with the supplied Hex Key Tool. Occasionally, a flat head screwdriver may be required.



Detail A

Typical Connection



Typical Connection (cont'd)

Most horizontal extrusion connections have a patented expandable lock. This lock inserts into the groove of an opposing extrusion. Tightening the lock with the Hex Key Tool expands the lock and creates a strong positive connection.

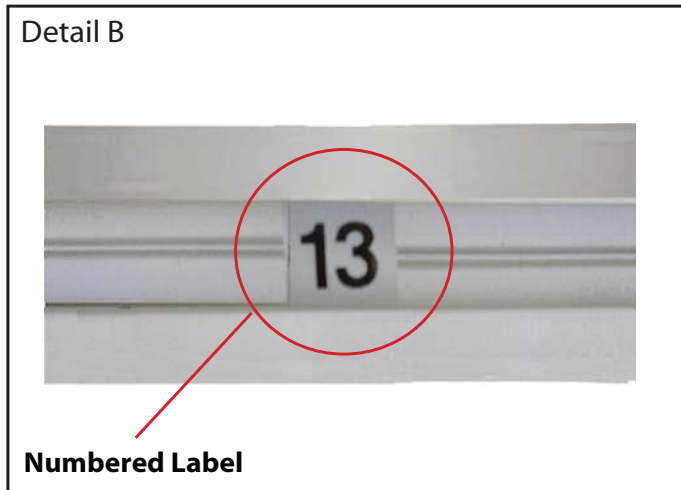

Detail B

Numbered Label

Each extrusion contains a numbered label which corresponds with setup instructions. The label is located within a groove of the extrusion (when possible). With Visionary Designs the labels contain Black numbers unless otherwise specified.



Detail C

Horizontal Inline Connection (remove only one setscrew)

Remove only (1) setscrew when disassembling. Replace setscrew in extrusion after assembling it. Before packing, replace setscrew in extrusion to avoid losing it.

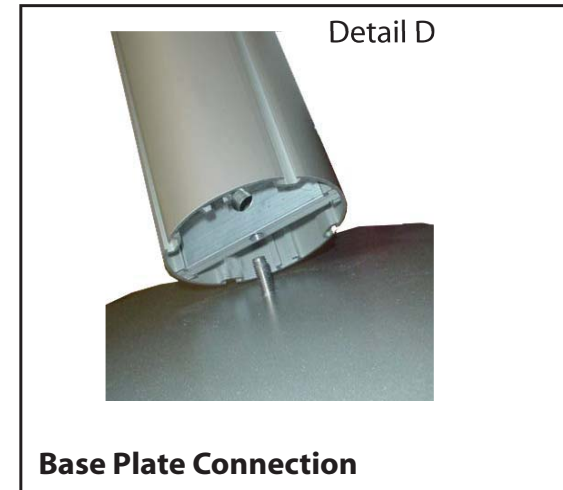

Detail D

Base Plate Connection

Attach base plate to round or square vertical extrusion using the bolt provided. Be careful not to strip the threads.

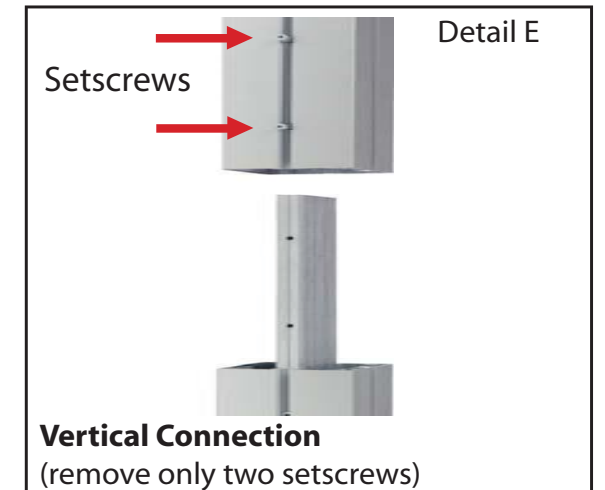

Detail E

Vertical Connection
(remove only two setscrews)

When vertical extrusions are packed in portable cases rather than crates or tubs, they must be broken down into smaller sections which then require assembly.

Remove only (2) setscrews when disassembling. Replace setscrews in extrusion after assembling it. Before packing, replace setscrews in extrusion to avoid losing them.

WHEN DISASSEMBLING ALUMINUM EXTRUSION, TIGHTEN ALL SETSCREWS AND LOCKS TO PREVENT LOSS DURING SHIPPING

866.652.2100

Part Number	Qty for Step	Description
1/1a	1/1	Base Plate
2	1	80"h Vertical Extrusion
3	1	80"h Vertical Extrusion
4	1	86"w Horizontal Extrusion
5	1	86"w Horizontal Extrusion
6	1	86"w Horizontal Extrusion
7	1	86"w Horizontal Extrusion

Steps:

- 1) Attach vertical extrusions [2 and 3] to base plates [1].
- 2) Attach horizontal extrusions between vertical extrusions as shown.

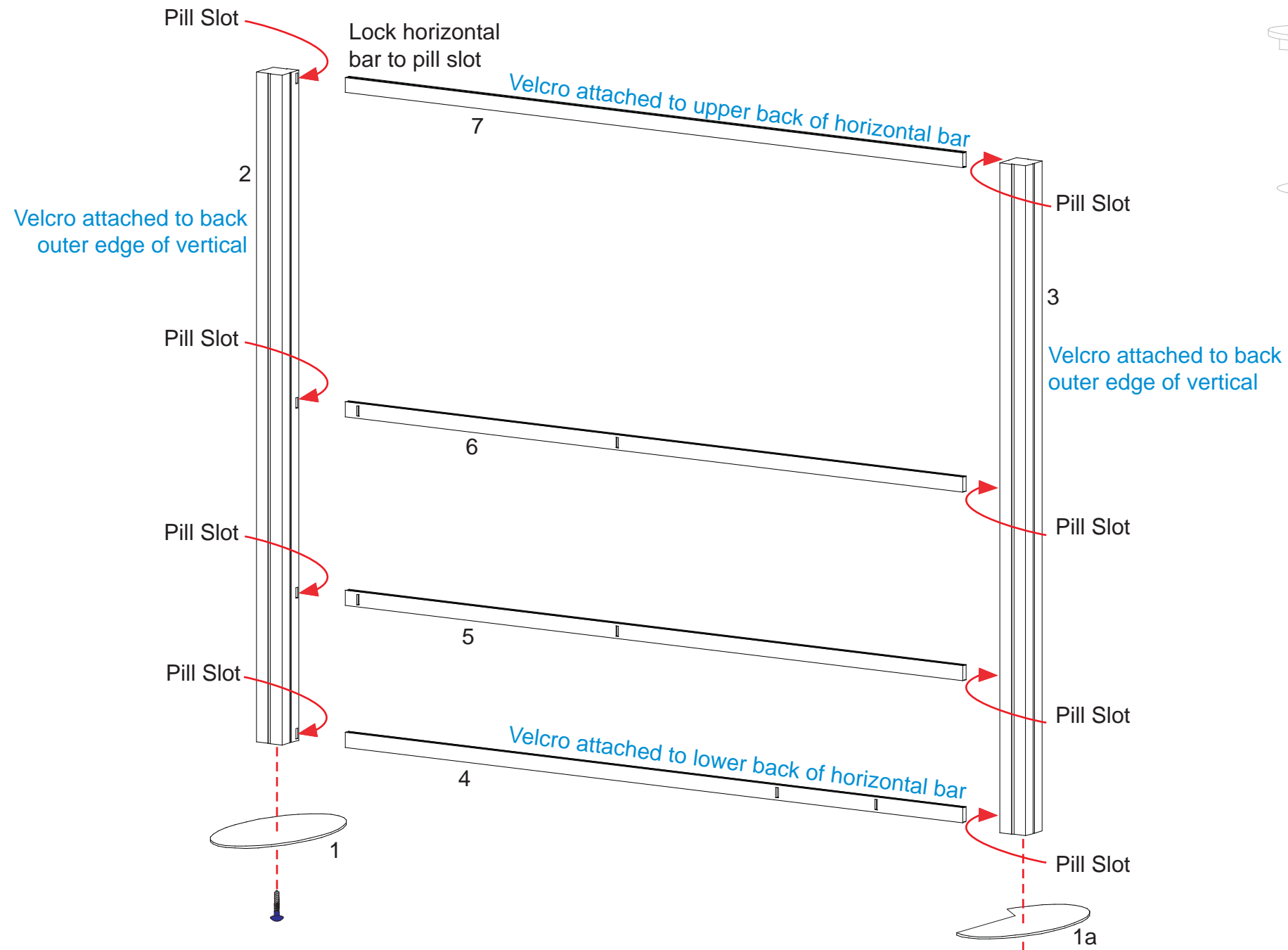

WHEN DISASSEMBLING ALUMINUM EXTRUSION, TIGHTEN ALL SETSCREWS AND LOCKS TO PREVENT LOSS DURING SHIPPING

866.652.2100

Part Number	Qty for Step	Description
8	1	9" w Horizontal Extrusion
9	1	13" w Horizontal Extrusion
10	1	3" w Horizontal Extrusion

Steps:
 1) Lock horizontal extrusions [8, 9 and 10] to pill slots on backwall horizontal bars as shown.

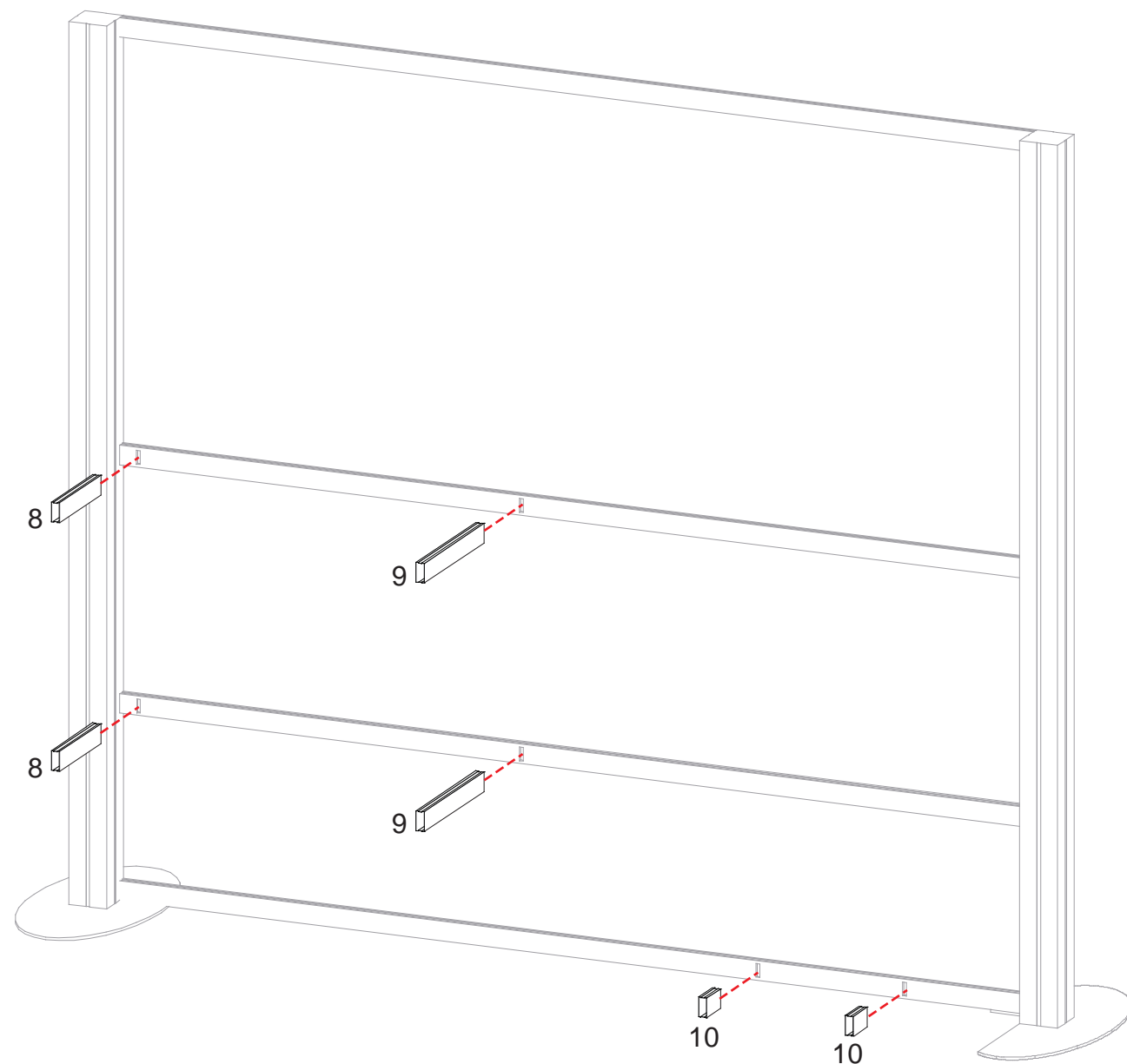
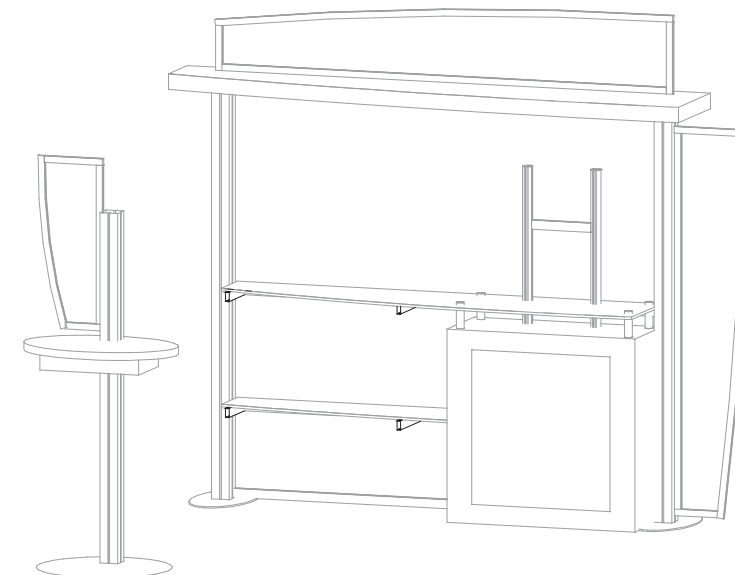

WHEN DISASSEMBLING ALUMINUM EXTRUSION, TIGHTEN ALL SETSCREWS AND LOCKS TO PREVENT LOSS DURING SHIPPING

866.652.2100

Steps:

- 1) Slide cabinet box in front on backwall horizontal bars.
- 2) Attach standoff barrels to top of cabinet box.
- 3) Place Plex shelves atop horizontal bars [8 and 9] and upper shelf atop standoffs.
- 4) Secure upper shelf with standoff caps.

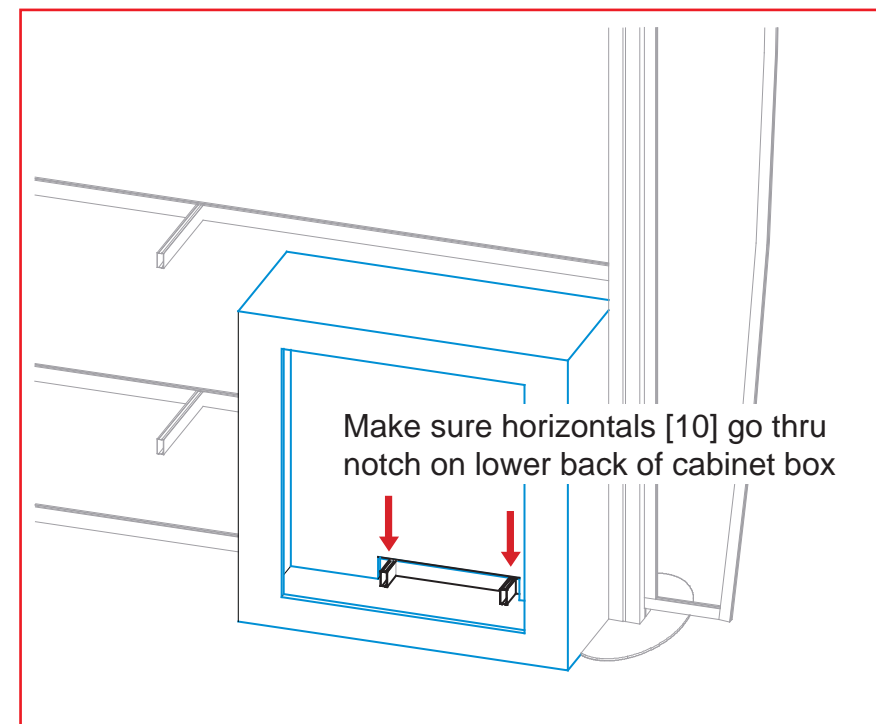
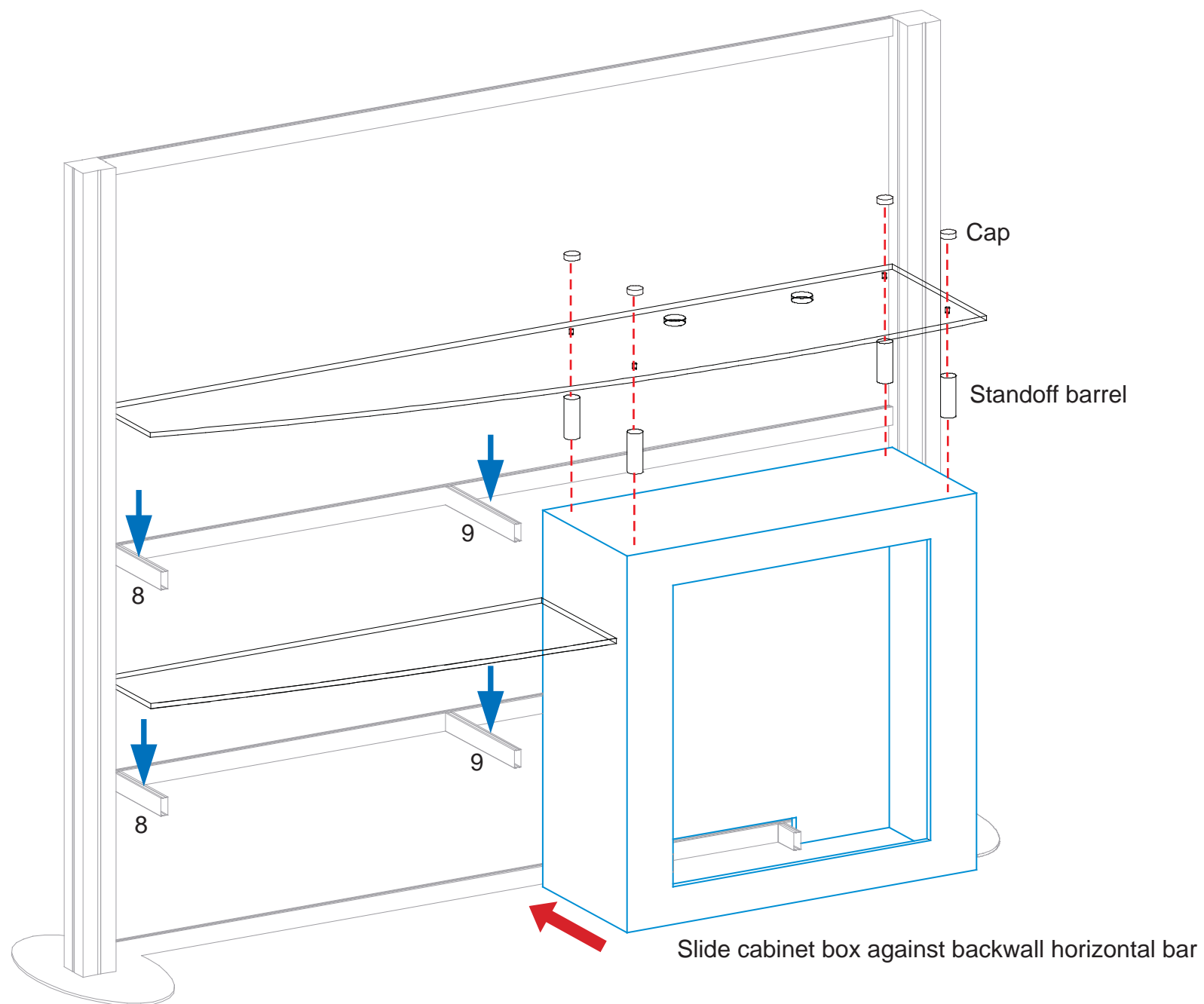
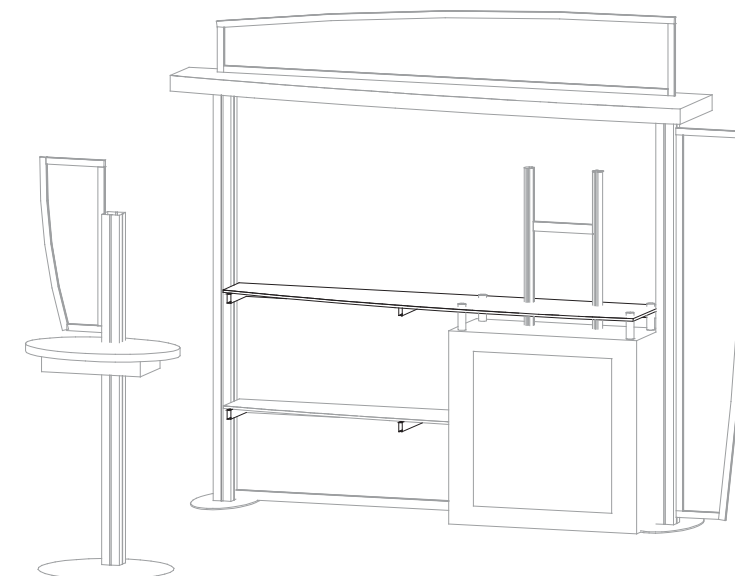

WHEN DISASSEMBLING ALUMINUM EXTRUSION, TIGHTEN ALL SETSCREWS AND LOCKS TO PREVENT LOSS DURING SHIPPING

866.652.2100

Part Number	Qty for Step	Description
11	1	68" h Vertical Extrusion
12	1	68" h Vertical Extrusion
13	3	12" w Horizontal Extrusion

- Steps:
- 1) Slide vertical extrusions [11 and 12] thru shelf and cabinet box from top.
 - 2) Secure vertical extrusions to horizontal extrusions [10] as shown.
 - 3) Slide horizontal extrusions [13] between vertical extrusions [11 and 12], then tighten locks to secure in place at desired height.

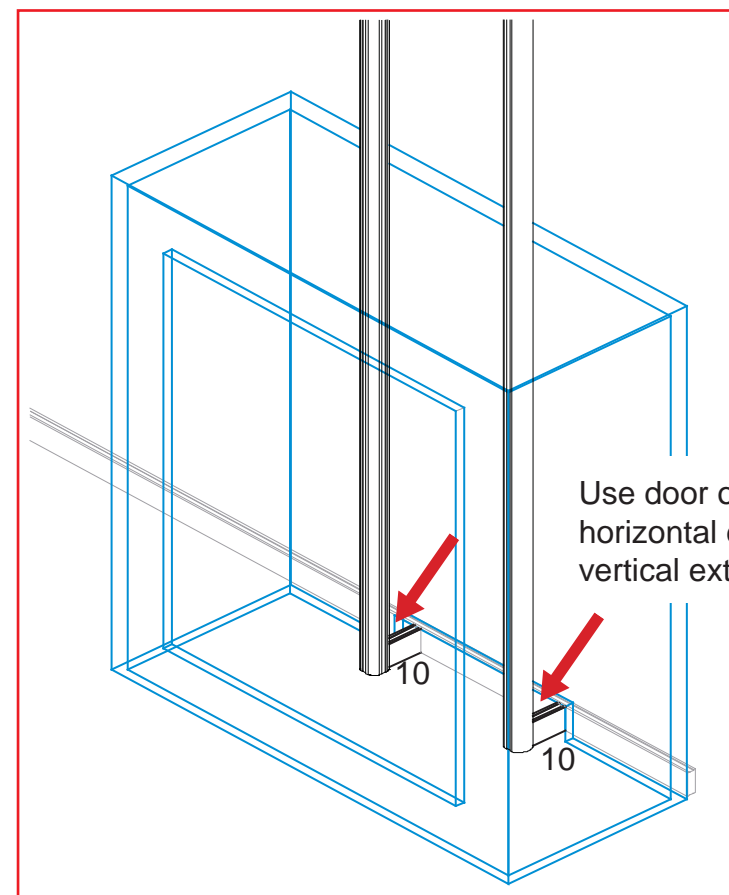
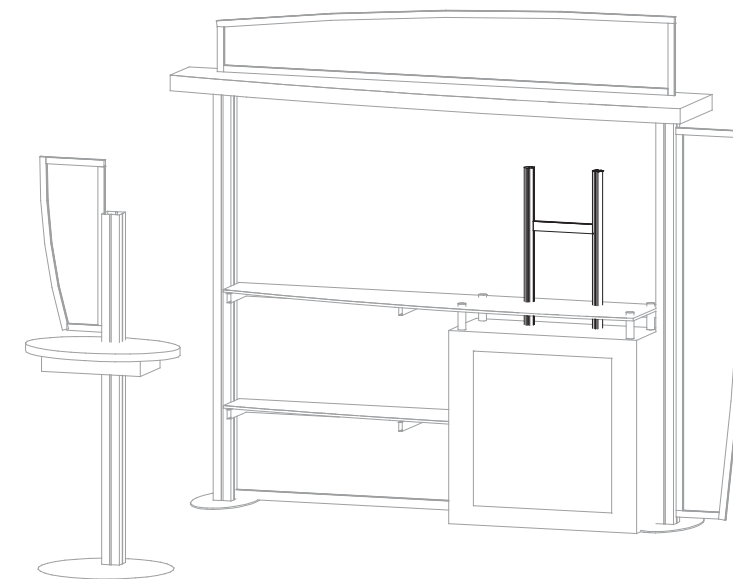
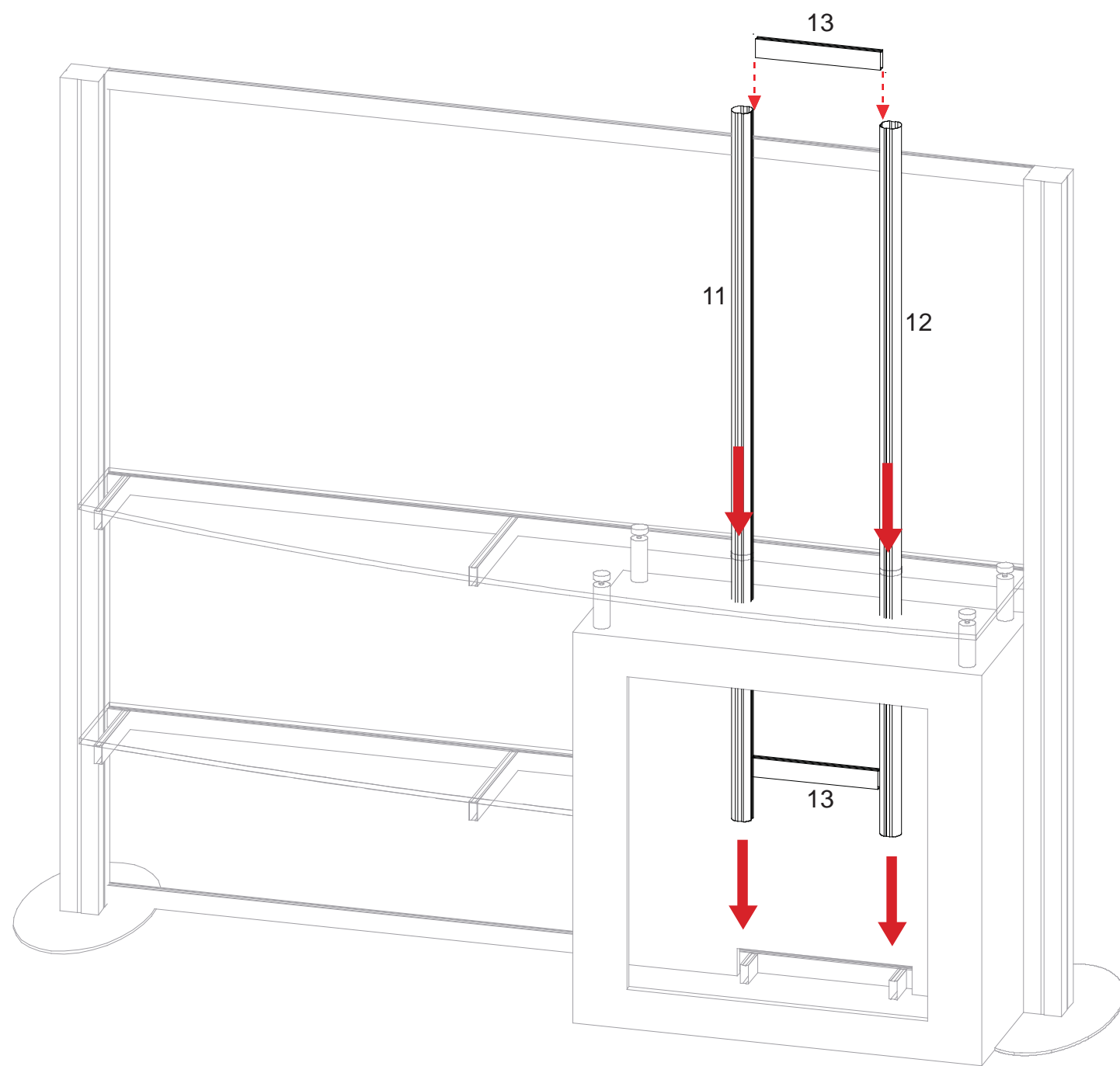

Use door opening to lock horizontal extrusions to vertical extrusions.

WHEN DISASSEMBLING ALUMINUM EXTRUSION, TIGHTEN ALL SETSCREWS AND LOCKS TO PREVENT LOSS DURING SHIPPING

866.652.2100

Part Number	Qty for Step	Description
A	1	89.965" Lower Horizontal
B	1	8.738" Tapered cut Vertical
C	1	14" Tapered cut Vertical
D	1	92.92" Curved Horizontal

- Steps:
- 1) Attach header pieces together as shown.
 - 2) Apply pillow case graphic to assembled header.

NOTE: Header frame must stay assembled when shipping in crate

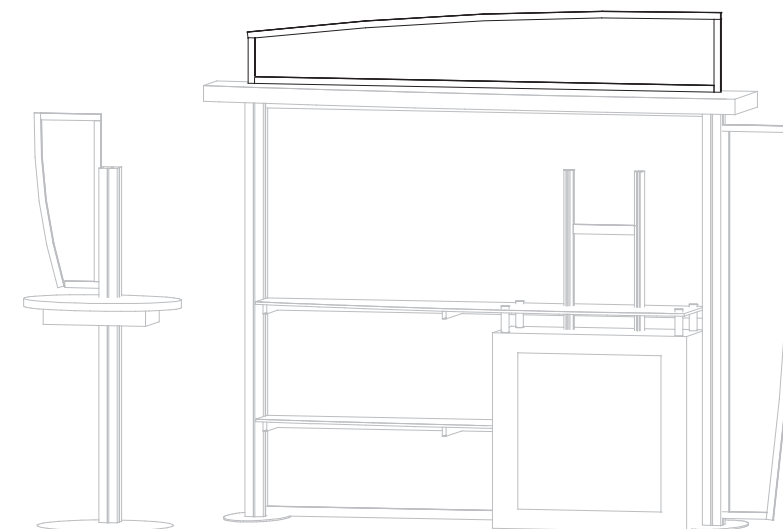

Note: Frame should be assembled from Backside.

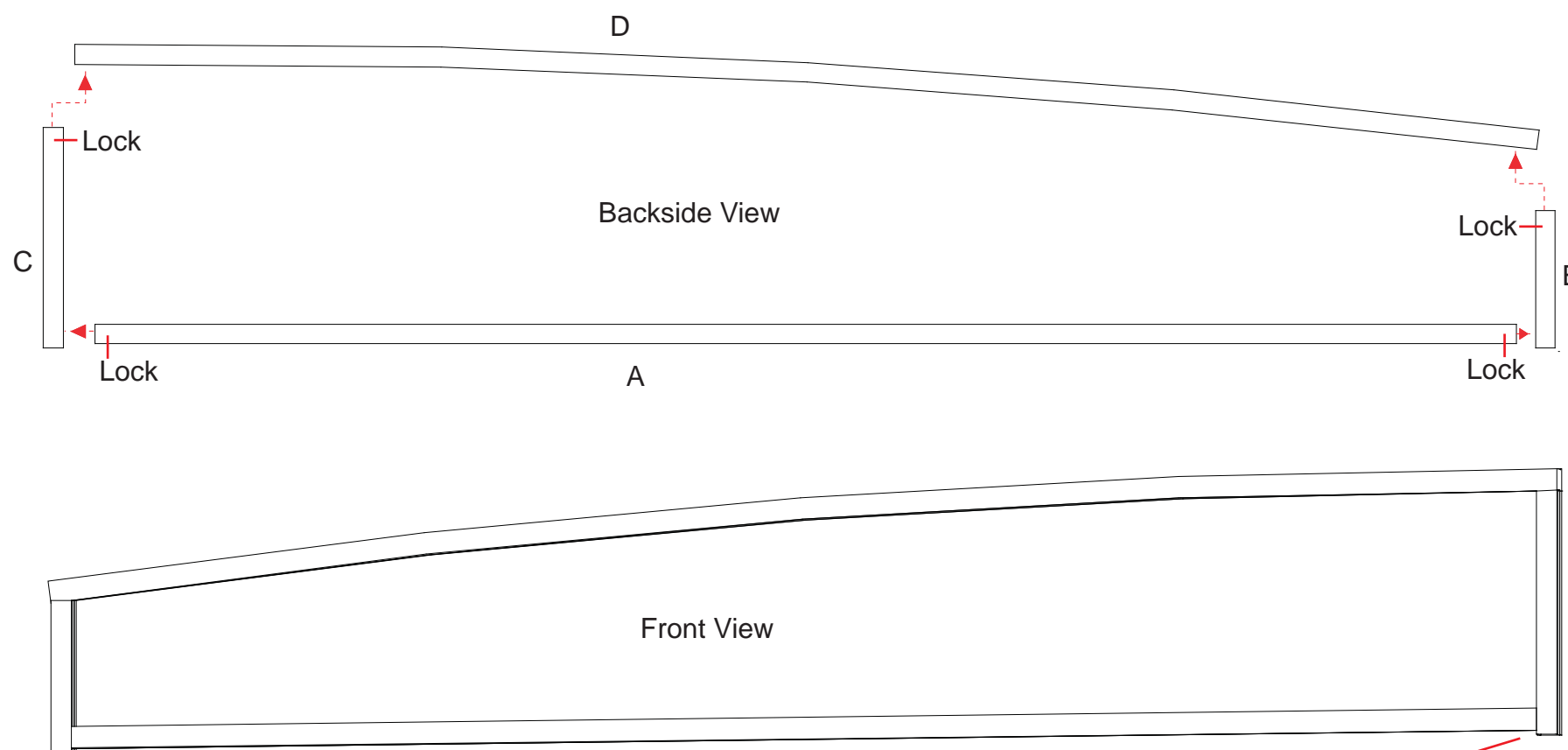

Please note that bottom horizontal sits 1/4" in to allow for zipper on pillowcase graphic.

WHEN DISASSEMBLING ALUMINUM EXTRUSION, TIGHTEN ALL SETSCREWS AND LOCKS TO PREVENT LOSS DURING SHIPPING

866.652.2100

Part Number	Qty for Step	Description
E	1	73" Side Vertical
F	1	14" Tapered cut Horizontal
G	1	8.77" Tapered cut Horizontal
H	1	75.74" Curved Vertical

Steps:
 1) Attach wing pieces together as shown.
 2) Apply pillow case graphic to assembled wing.
NOTE: Wing frame must stay assembled when shipping in crate

Note: Frame should be assembled from Backside.

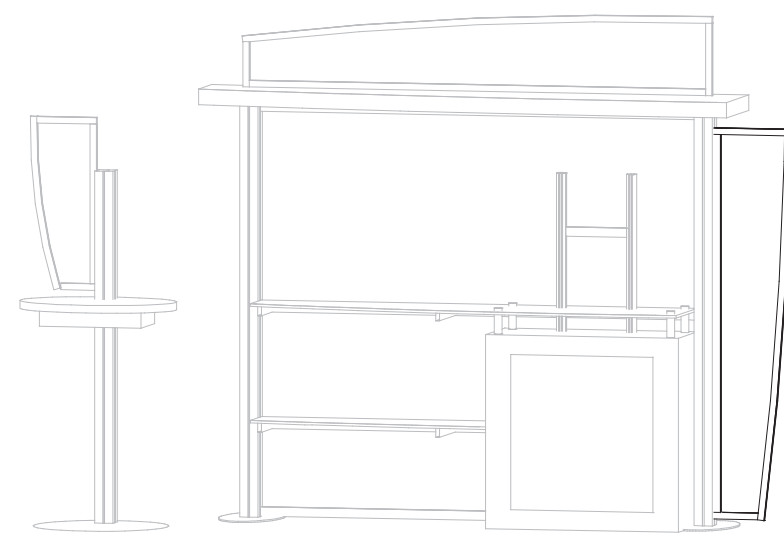
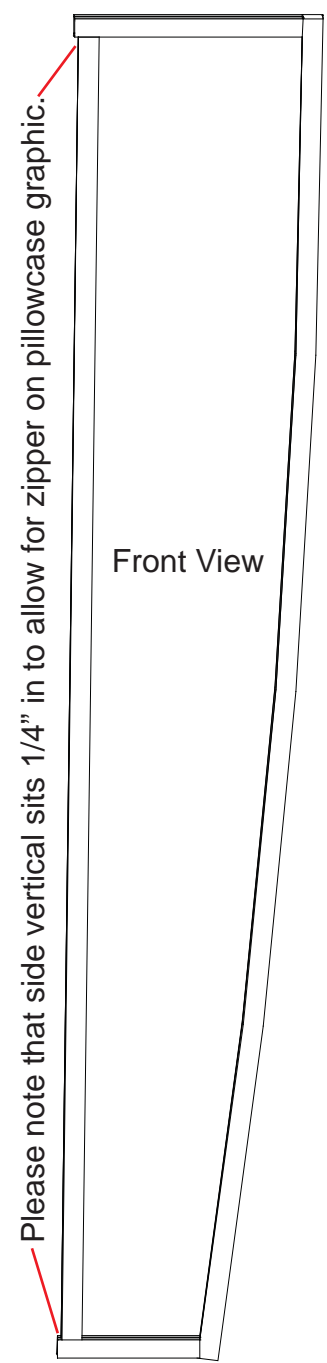
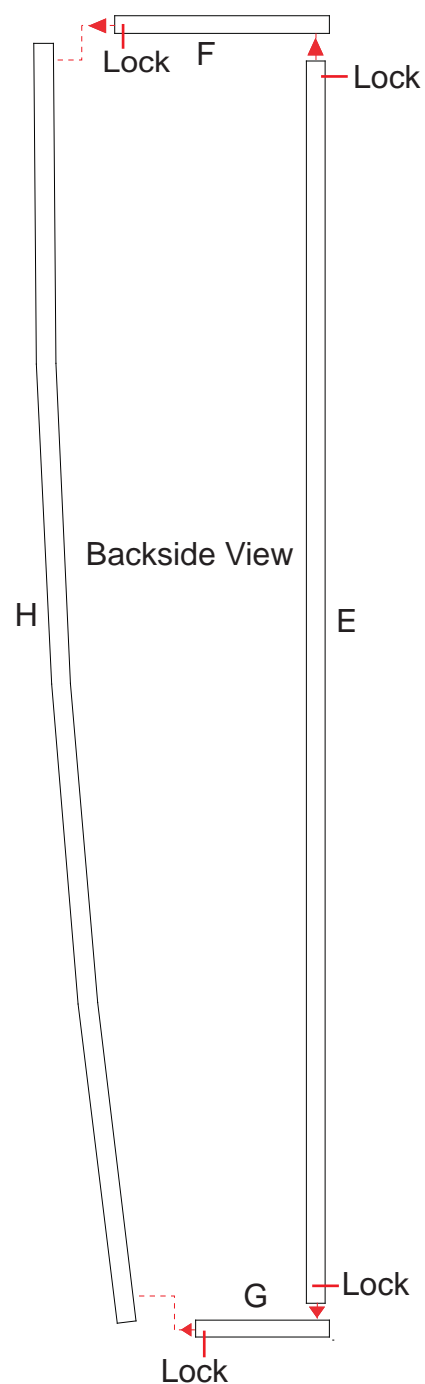

WHEN DISASSEMBLING ALUMINUM EXTRUSION, TIGHTEN ALL SETSCREWS AND LOCKS TO PREVENT LOSS DURING SHIPPING

866.652.2100

Steps:

- 1) Attach ceiling to vertical extrusion using bolts.
- 2) attach assembled header frame to ceiling by locking to connectors where indicated.
- 3) Lock assembled wing with graphic to vertical extrusion as shown.

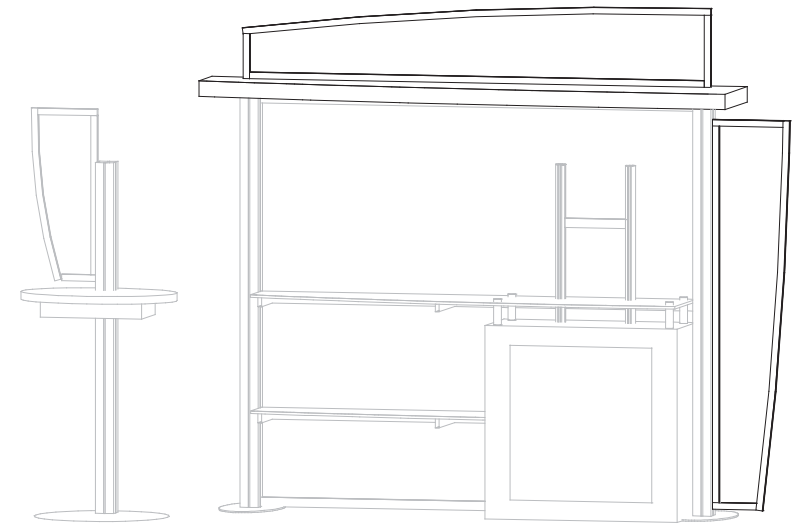
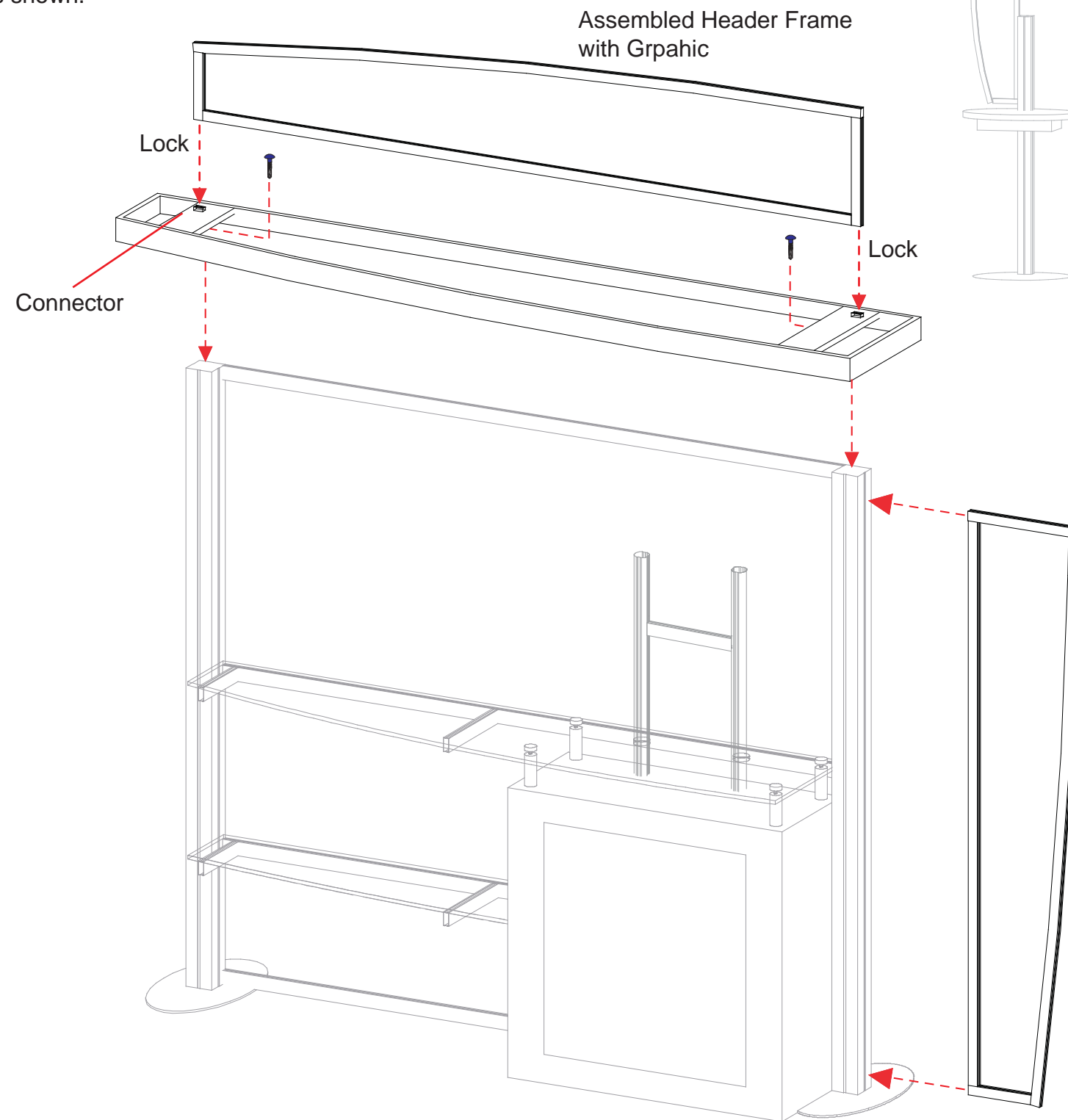
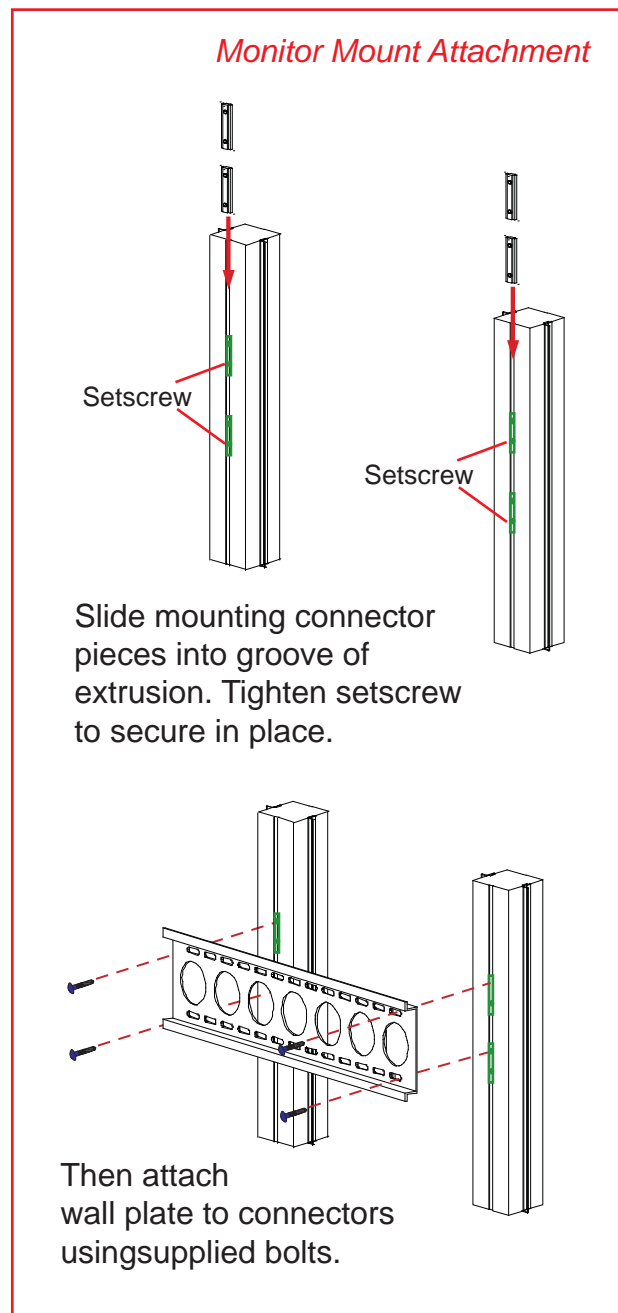

WHEN DISASSEMBLING ALUMINUM EXTRUSION, TIGHTEN ALL SETSCREWS AND LOCKS TO PREVENT LOSS DURING SHIPPING

866.652.2100

Part Number	Qty for Step	Description
I	1	30.862" Straight Vertical
J	1	11.75" Tapered cut Horizontal
K	1	7.27" Tapered cut Horizontal
L	1	33.909" Curved Vertical

- Steps:
- 1) Attach wing pieces together as shown.
 - 2) Apply pillow case graphic to assembled wing.

NOTE: Wing frame must stay assembled when shipping in crate

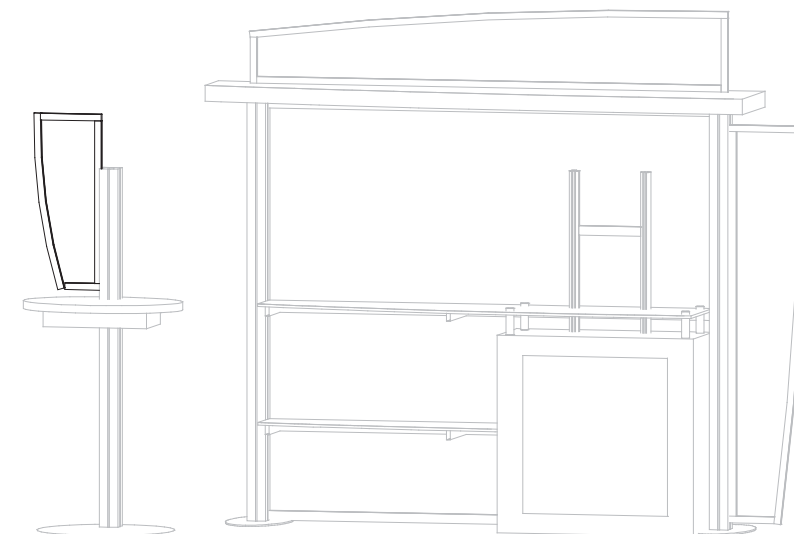

Note: Frame should be assembled from Backside.

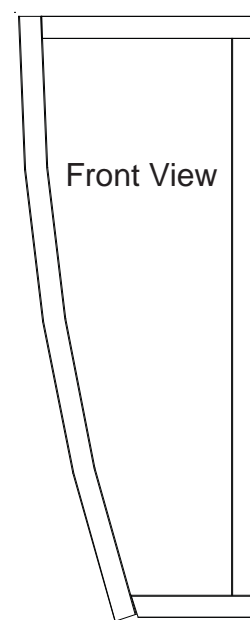
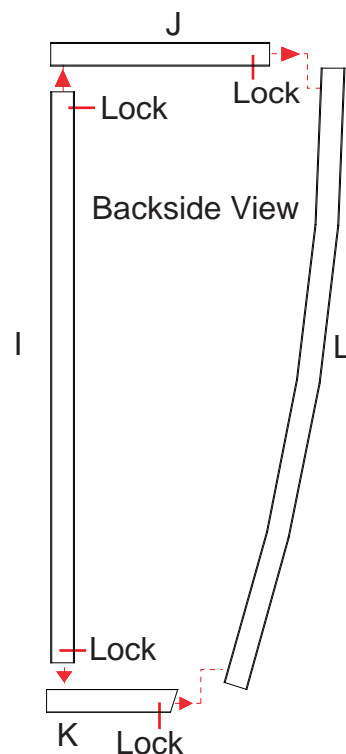

Please note that side vertical sits 1/4" (ONLY on BOTTOM) in to allow for zipper on pillowcase graphic.

WHEN DISASSEMBLING ALUMINUM EXTRUSION, TIGHTEN ALL SETSCREWS AND LOCKS TO PREVENT LOSS DURING SHIPPING

866.652.2100

Part Number	Qty for Step	Description
14	1	Base Plate
15	1	68" h Vertical Extrusion
16	1	11.5" w Horizontal Extrusion
17	2	Counter Support Extrusion

Steps:

- 1) Attach vertical extrusion [15] to base plate [14].
- 2) Attach horizontal extrusions [16] to vertical extrusion at desired height.
- 3) Slide cubby on horizontal extrusion [16].
- 4) Attach counter supports [17] to vertical extrusion as shown.
- 5) Attach assembled wing with graphic to vertical extrusion as shown.

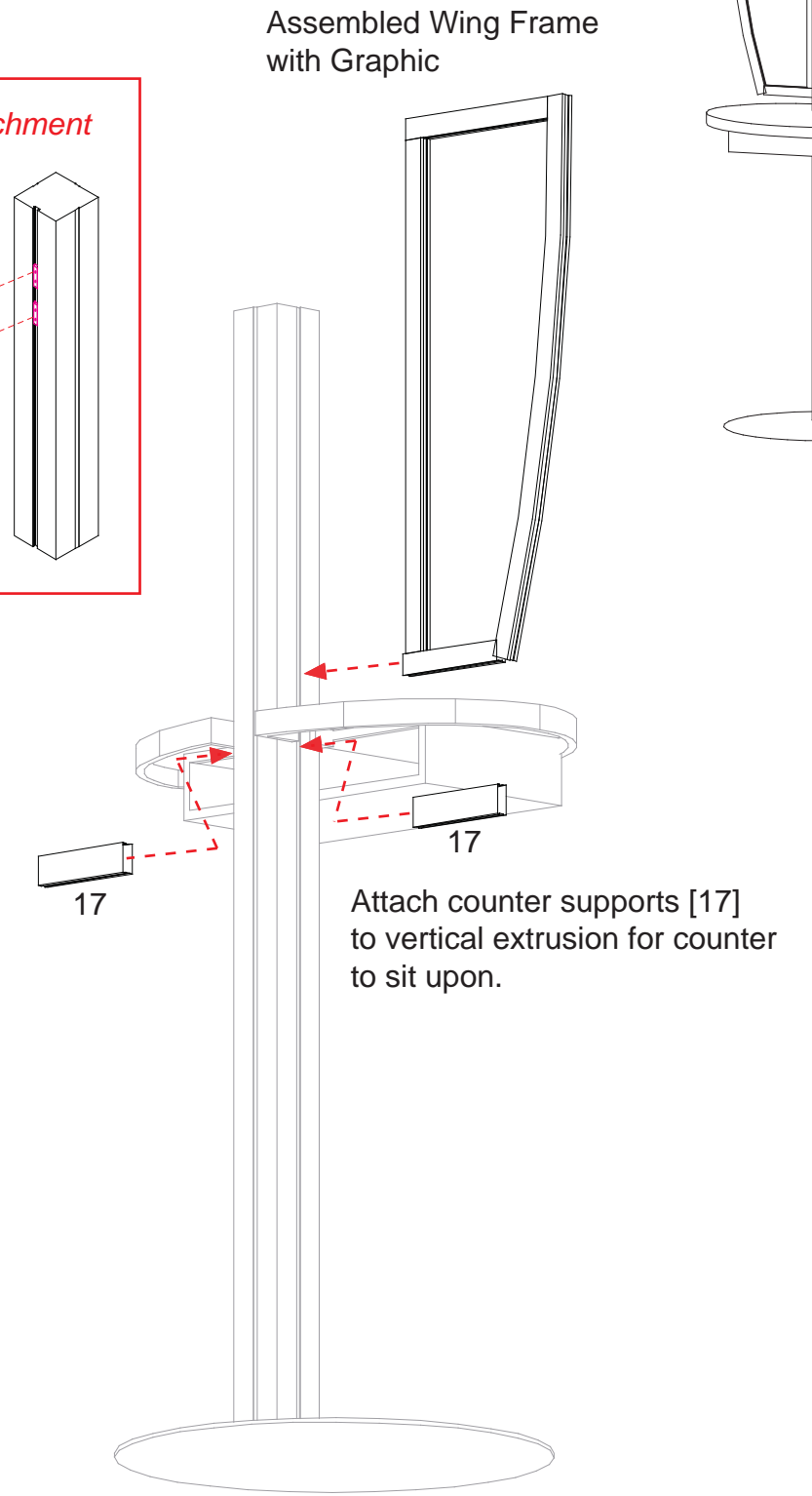
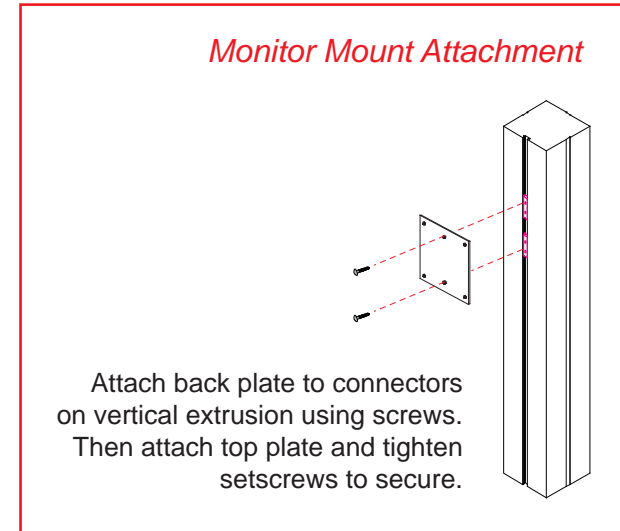
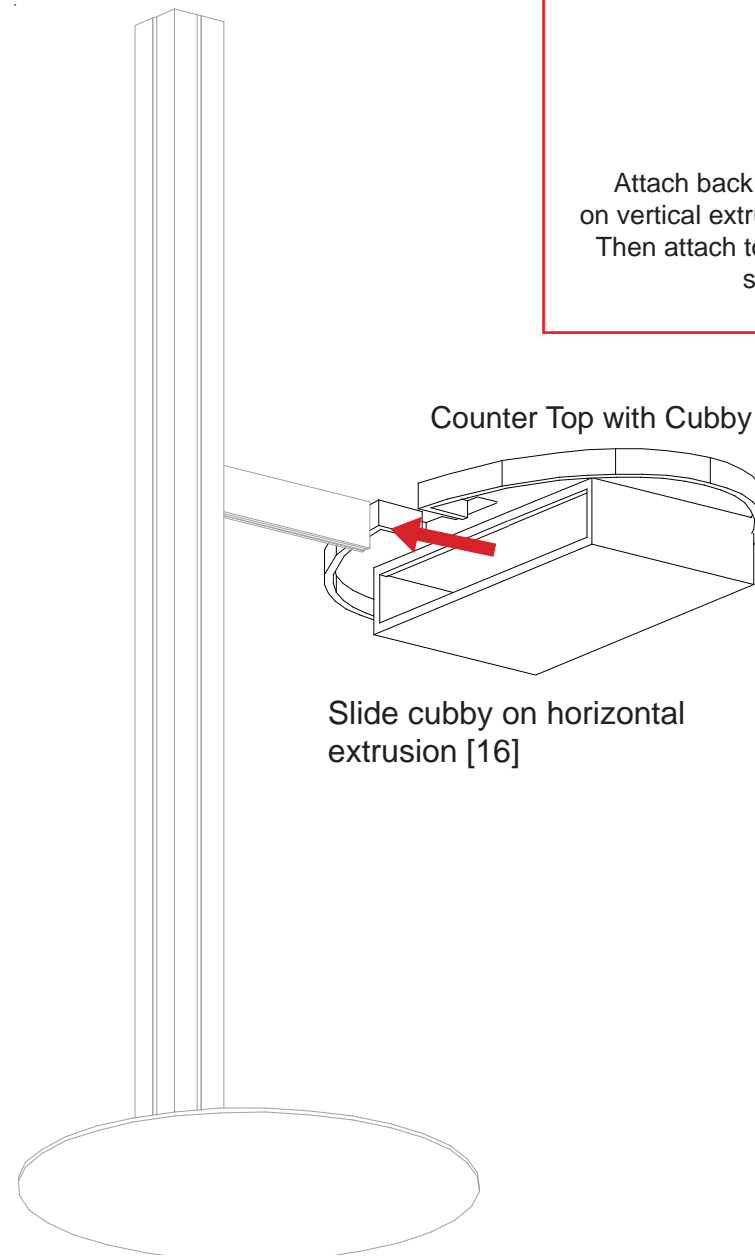
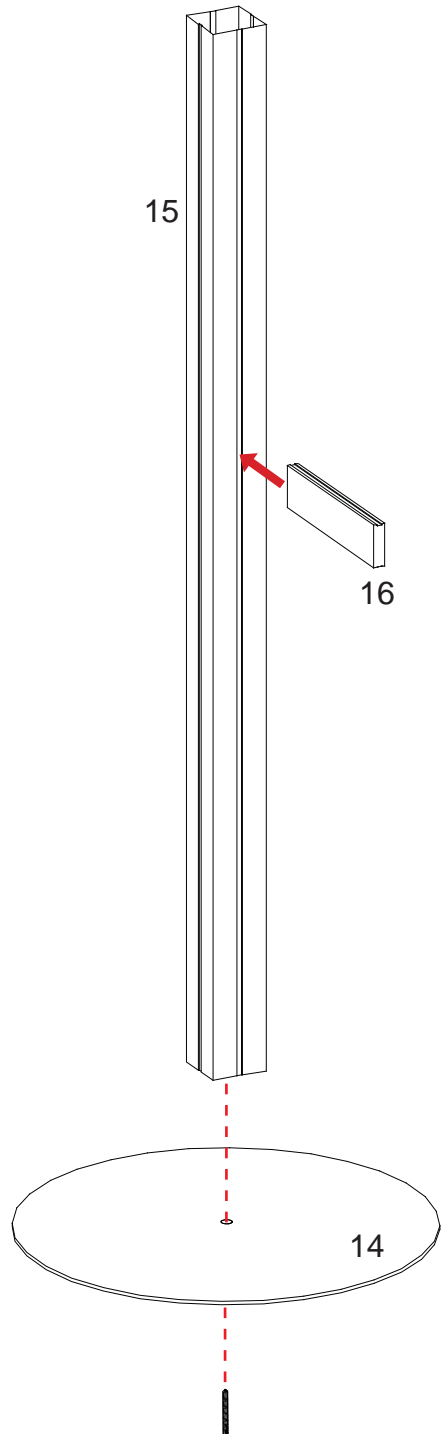

Assembled Wing Frame with Graphic

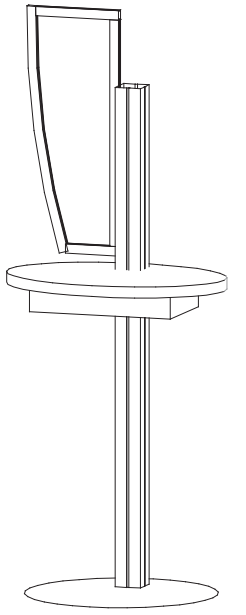

WHEN DISASSEMBLING ALUMINUM EXTRUSION, TIGHTEN ALL SETSCREWS AND LOCKS TO PREVENT LOSS DURING SHIPPING

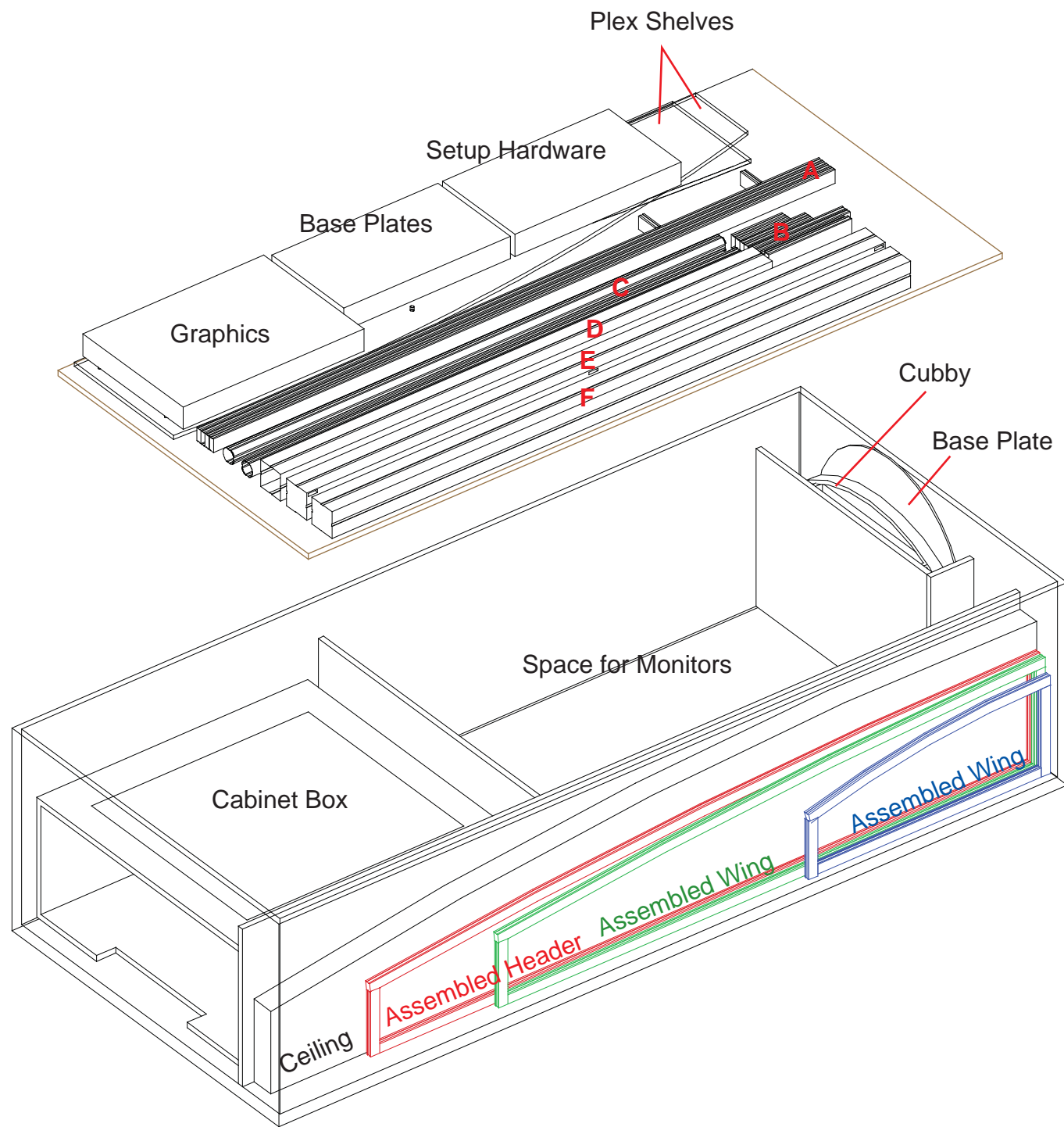

Part List

- A - (1) Extrusion #4 with
(2) Extrusions #10 attached
- (1) Extrusion #5
- (1) Extrusion #6
- (1) Extrusion #7
- B - (2) Extrusions #17
- (2) Extrusion #8
- (2) Extrusion #9
- (2) Extrusion #13
- (1) Extrusion #16
- C - (1) Extrusion #11
- (1) Extrusion #12
- D - (1) Extrusion #15
- E - (1) Extrusion #2
- F - (1) Extrusion #3



Level 1



Level 1

WHEN DISASSEMBLING ALUMINUM EXTRUSION, TIGHTEN ALL SETSCREWS AND LOCKS TO PREVENT LOSS DURING SHIPPING