

WHEN DISASSEMBLING ALUMINUM EXTRUSION, TIGHTEN ALL SETSCREWS AND LOCKS TO PREVENT LOSS DURING SHIPPING

# visionary™ IDESIGNS

## Using Your Setup Instructions

The Visionary Designs Setup Instructions are created specifically for your configuration. They are laid out sequentially, including an exploded view of the entire display, and then a logical series of detailed steps to assemble the main structure and components. We encourage you to study the instructions **before** attempting to assemble your exhibit.

Each page reminds you to tighten the setscrews after disassembling your exhibit to prevent loss of the locks and setscrews (see below in RED). This is **VERY IMPORTANT**.

## Cleaning and Packing Your Display

- 1) Use care when cleaning aluminum extrusion or acrylic inserts. Use only non-abrasive cleaners.
- 2) When cleaning laminate inserts or countertops, use mild cleansers and a soft material such as cotton.
- 3) Keep all display components away from extreme heat and long exposure to sunlight to avoid warping and fading.
- 4) Retain all packing material. It will make re-packing much easier and will reduce the likelihood of shipping damage.



**The Tool**

Most Visionary Designs exhibits can be assembled with the supplied Hex Key Tool. Occasionally, a flat head screwdriver may be required.



Detail A

**Typical Connection**



**Typical Connection (cont'd)**

Most horizontal extrusion connections have a patented expandable lock. This lock inserts into the groove of an opposing extrusion. Tightening the lock with the Hex Key Tool expands the lock and creates a strong positive connection.



Detail B

**Numbered Label**

Each extrusion contains a numbered label which corresponds with setup instructions. The label is located within a groove of the extrusion (when possible). With Visionary Designs the labels contain Black numbers unless otherwise specified.



Detail C

**Horizontal Inline Connection** (remove only one setscrew)

Remove only (1) setscrew when disassembling. Replace setscrew in extrusion after assembling it. Before packing, replace setscrew in extrusion to avoid losing it.

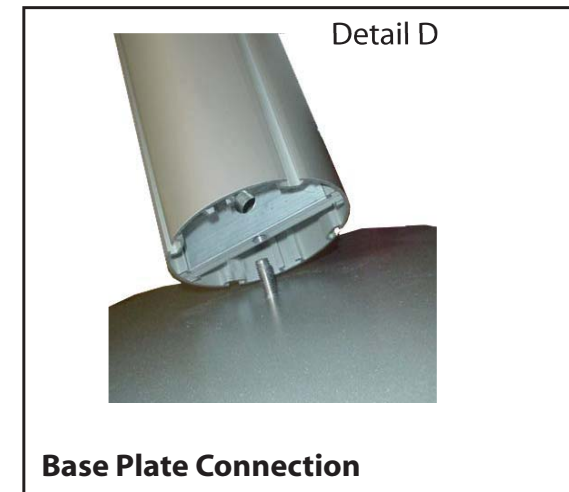

Detail D

**Base Plate Connection**

Attach base plate to round or square vertical extrusion using the bolt provided. Be careful not to strip the threads.



Detail E

**Vertical Connection**  
(remove only two setscrews)

When vertical extrusions are packed in portable cases rather than crates or tubs, they must be broken down into smaller sections which then require assembly.

Remove only (2) setscrews when disassembling. Replace setscrews in extrusion after assembling it. Before packing, replace setscrews in extrusion to avoid losing them.

**WHEN DISASSEMBLING ALUMINUM EXTRUSION, TIGHTEN ALL SETSCREWS AND LOCKS TO PREVENT LOSS DURING SHIPPING**

866.652.2100

Part Number	Qty	Description
1/1a	7/1	92"h Square Vertical extrusion
2	12	12"w Horizontal Extrusion
3	2	46"w Lower Horizontal w/ Velcro attached to Top of member
4	2	46"w Upper Horizontal w/ Velcro attached to Bottom of member
5	4	46"w Horizontal Extrusion

Steps

- 1) Attach lower horizontal extrusions [2 and 3] between vertical extrusions [1].
- 2) Place inserts where indicated.
- 3) Attach upper horizontal extrusions [2 and 4] between vertical extrusions [1] and atop inserts.
- 4) Attach horizontal extrusions [5] between vertical extrusions [1] where indicated, placing inserts between horizontals.
- 5) Apply graphics to assembled backwall, see Attaching Graphic Notes.

**Note: Attaching Graphics**  
 Attach Backwall Graphics to Velcro by on the BACK of Upper and Lower Horizontals.

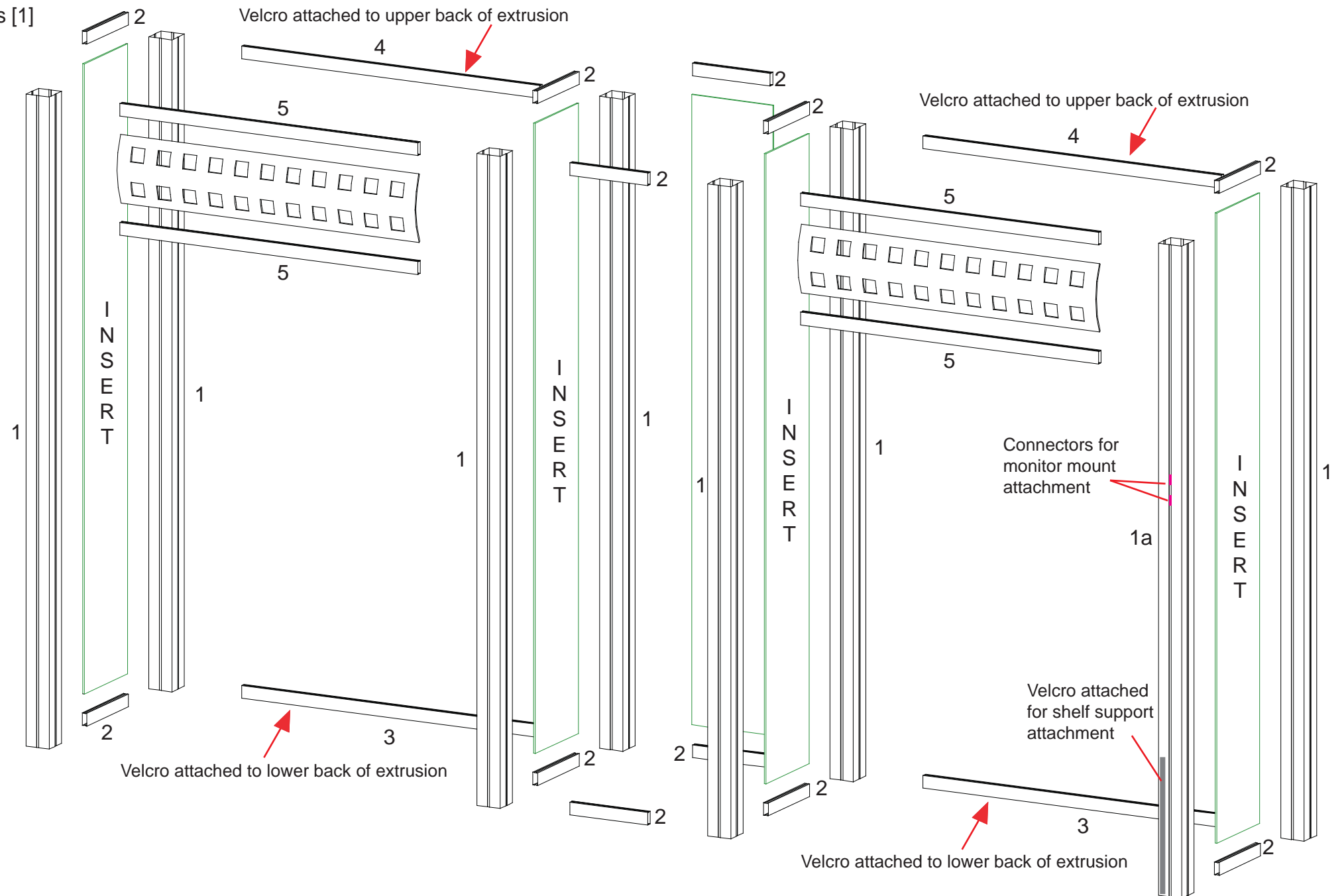

**WHEN DISASSEMBLING ALUMINUM EXTRUSION, TIGHTEN ALL SETSCREWS AND LOCKS TO PREVENT LOSS DURING SHIPPING**

866.652.2100

Part Number	Qty	Description
6	1	38" h Square Vertical extrusion w/ Door Stop
7	1	38" h Square Vertical extrusion w/ Door Hinges
8	1	38" h Square Vertical extrusion
9	4	12.5" w Horizontal Extrusion
10	4	27.5" w Horizontal Extrusion

Steps

- 1) Attach lower horizontal extrusions [9 and 10] between vertical extrusions [1, 6, 7 and 8].
- 2) Place inserts and attach door where indicated.
- 3) Attach upper horizontal extrusions [9 and 10] between vertical extrusions [1, 6, 7 and 8] and atop inserts and door.
- 4) Place hooks on horizontal extrusions where indicated, then set floor atop hooks.
- 5) Velcro shelf supports to inside of assembled base and atop floor, then set internal shelf atop supports.
- 6) Set counter top on assembled base.

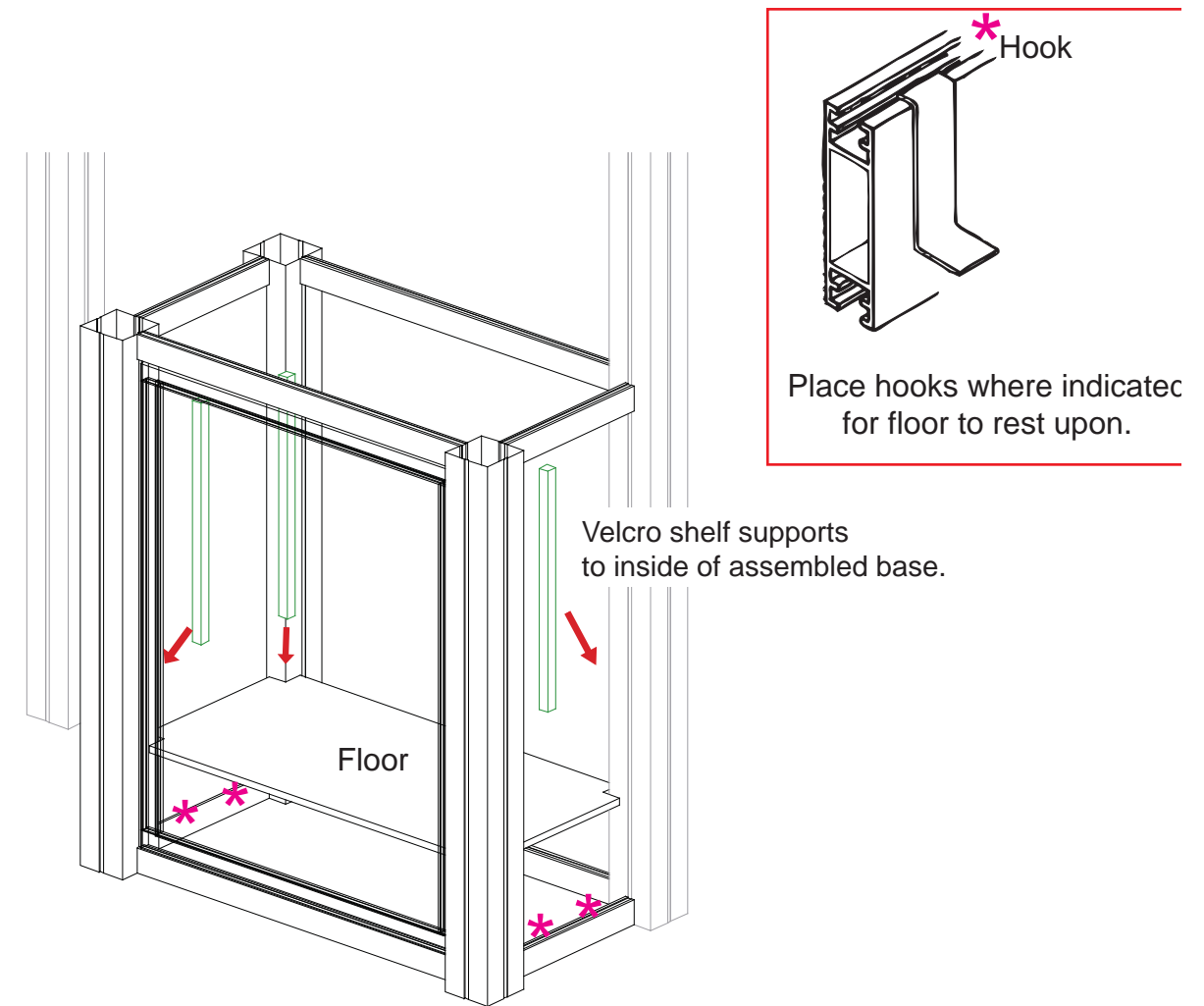
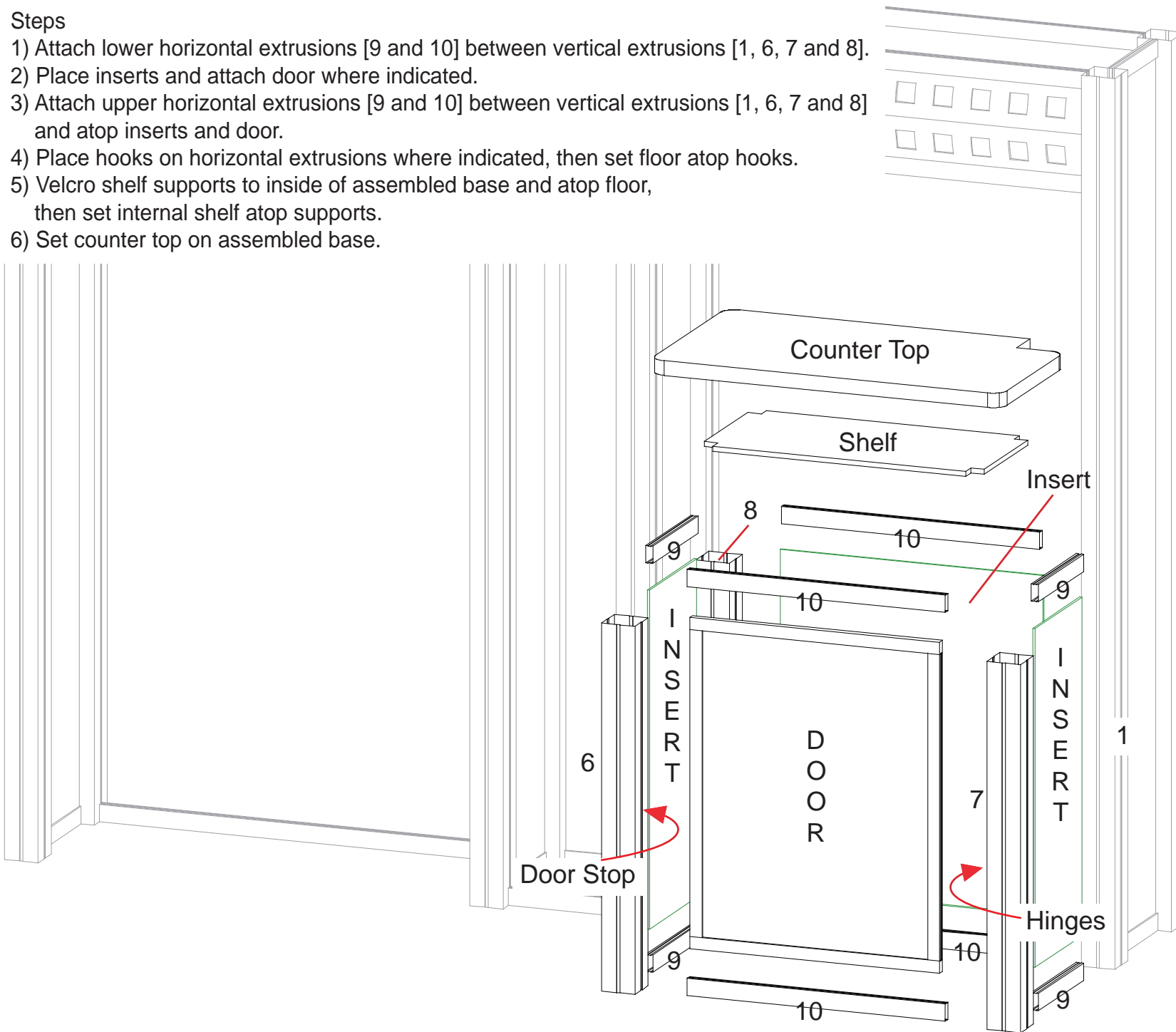

**WHEN DISASSEMBLING ALUMINUM EXTRUSION, TIGHTEN ALL SETSCREWS AND LOCKS TO PREVENT LOSS DURING SHIPPING**

Part Number	Qty	Description
11	1	84.335" h Curved Vertical Extrusion
12	1	84.335" h Curved Vertical Extrusion
13	1	13.79" w Horizontal Extrusion
14	1	13.79" w Horizontal Extrusion
15	2	11" w Horizontal Extrusion
16	2	11" w Horizontal Extrusion

Steps

- 1) Connect horizontal extrusions [13 and 14] between curved extrusions [11 and 12].
- 2) Attach graphic to back of assembled frame.
- 3) Attach horizontal extrusions [15 and 16] to back of assembled frame, placing inserts between horizontal extrusions.
- 4) Attach assembled frame to vertical extrusions [1].

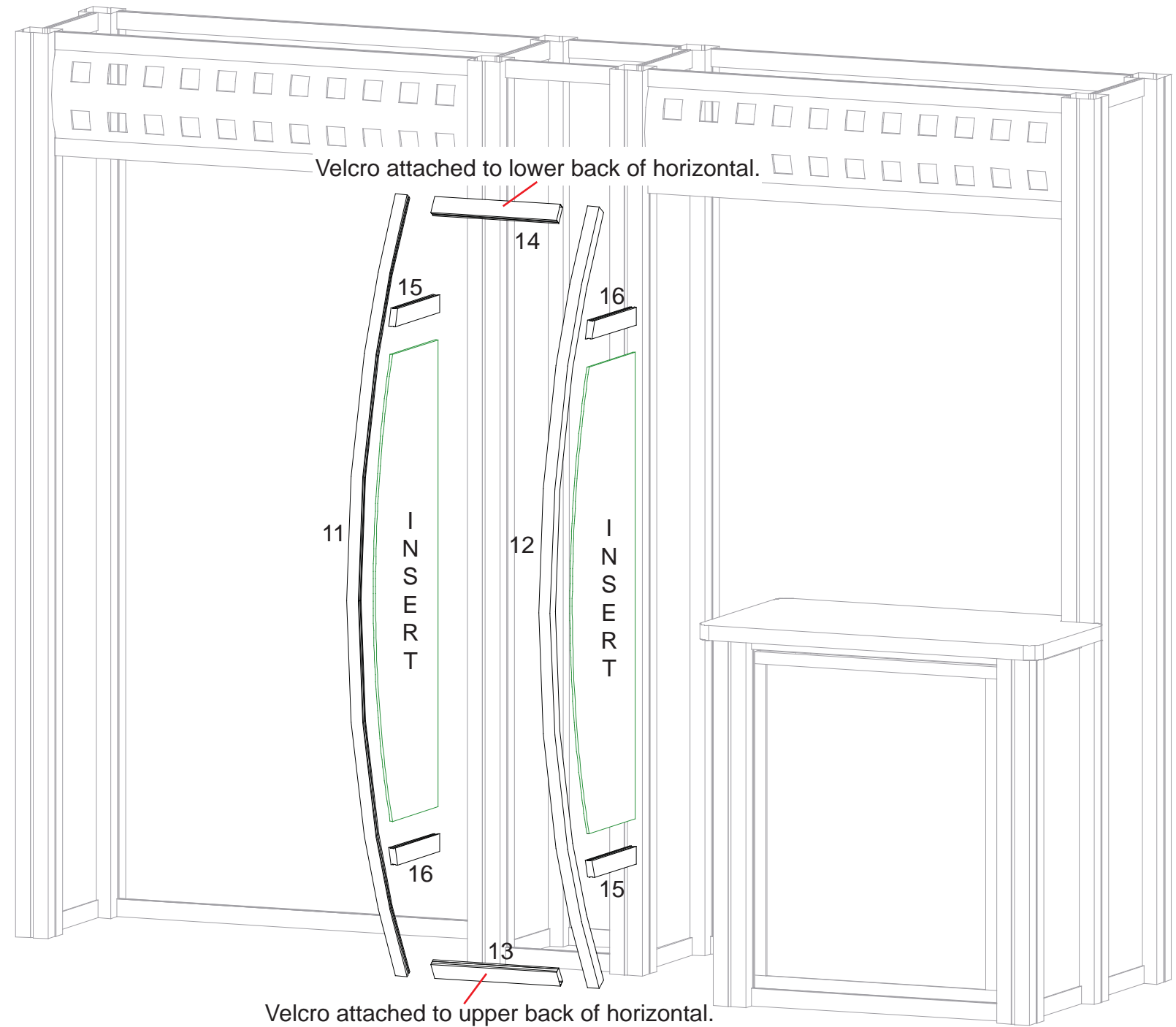
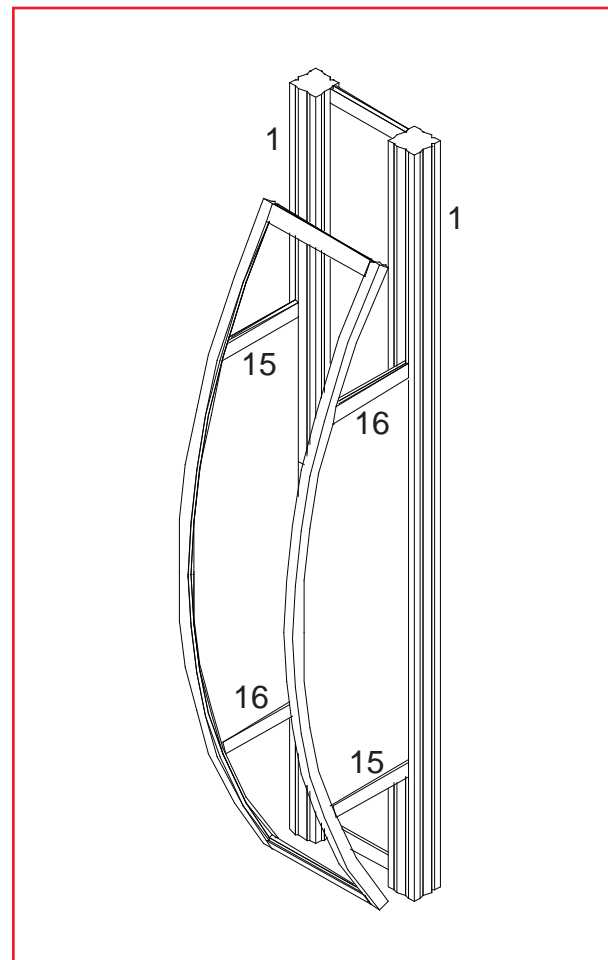

**WHEN DISASSEMBLING ALUMINUM EXTRUSION, TIGHTEN ALL SETSCREWS AND LOCKS TO PREVENT LOSS DURING SHIPPING**

866.652.2100

Part Number	Qty	Description
17	2	6"w Horizontal Extrusion

Steps

- 1) Attach assembled header to top of assembled backwall using horizontal extrusions [17].
- 2) Attach monitor mount where indicated.

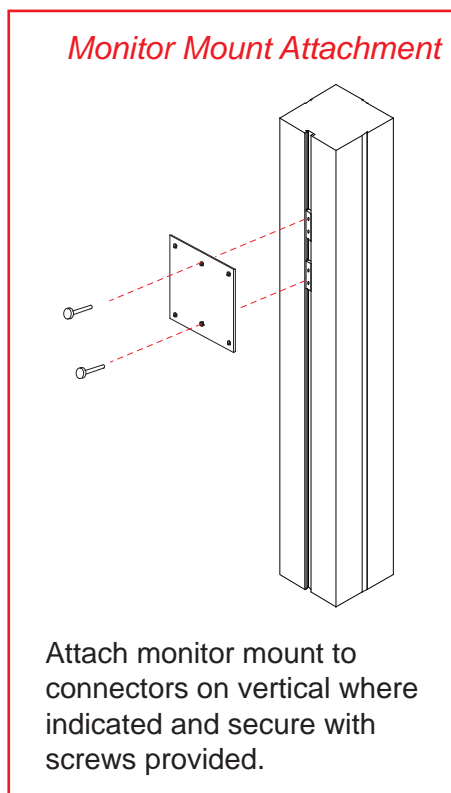
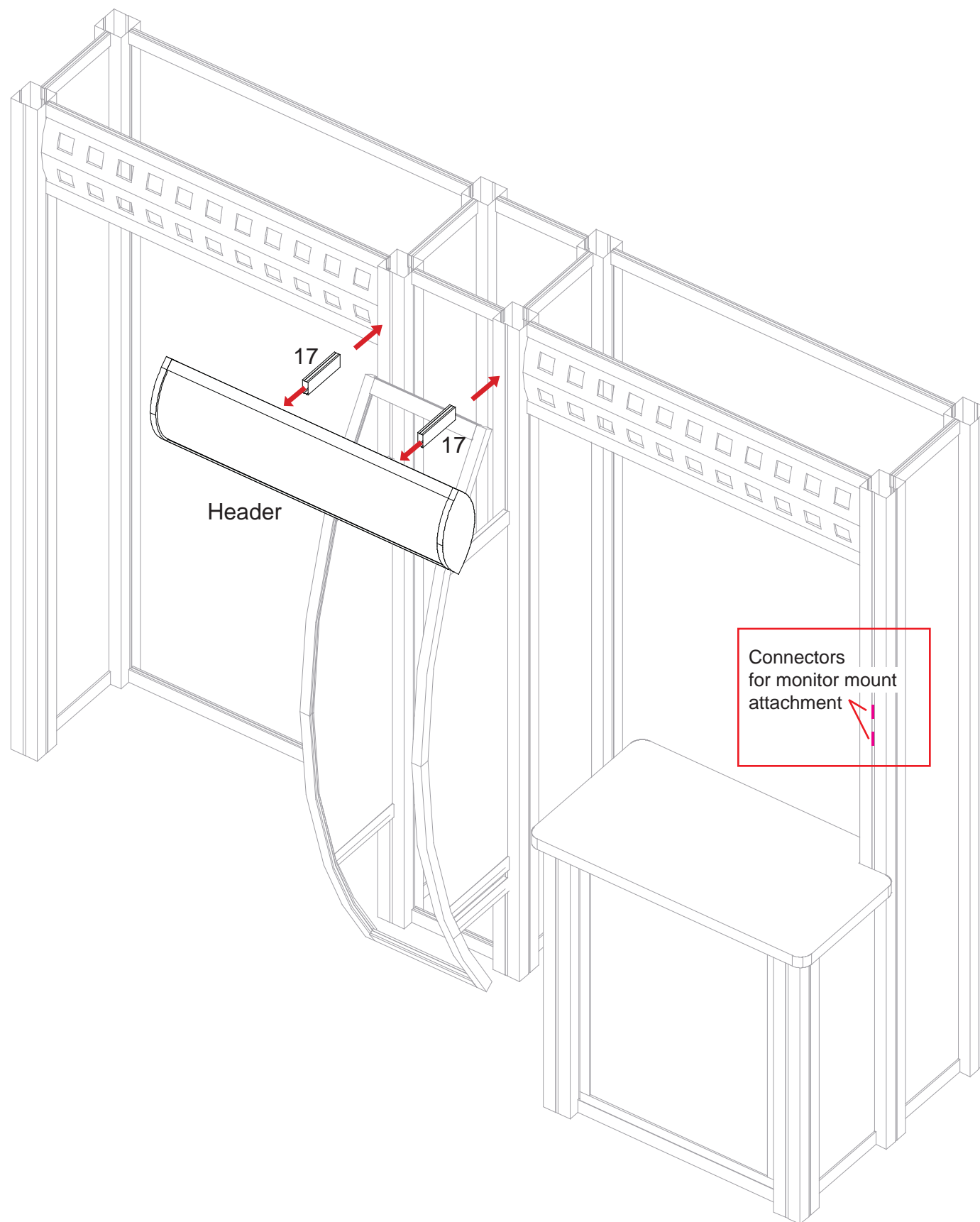

**WHEN DISASSEMBLING ALUMINUM EXTRUSION, TIGHTEN ALL SETSCREWS AND LOCKS TO PREVENT LOSS DURING SHIPPING**

LT Panel - Part List

Item Number	Description
1	23"w x 42"h Flat Panel w/ Door
2	42"h 90° Corner Connector
3	14.125"w x 42"h Flat Panel
4	42"h 90° Corner Connector w/ Notch for Hook
5	23"w x 42"h Flat Panel
6	42"h 90° Corner Connector w/ Notch for Hook
7	14.125"w x 42"h Flat Panel
8	42"h 90° Corner Connector

Steps:

- 1) Assemble pedestal base by starting at panel #1 and continue in numerical order.
- 2) Attach floor to inside of assembled base.
- 3) Velcro internal shelf supports to inside of assembled LT base and atop floor.
- 4) Set internal shelf atop supports.

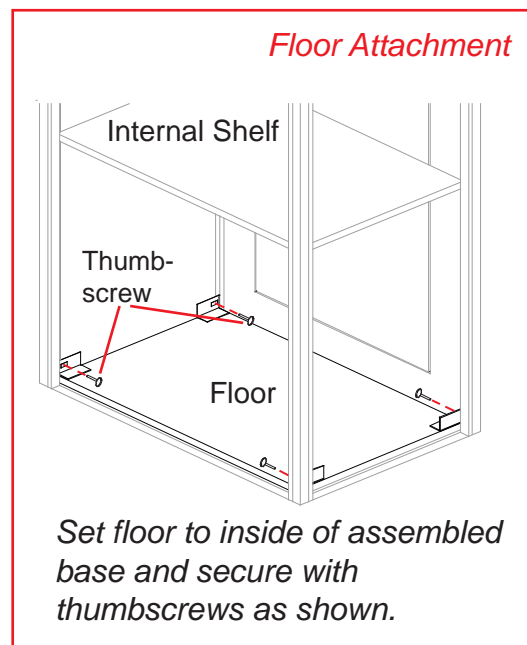
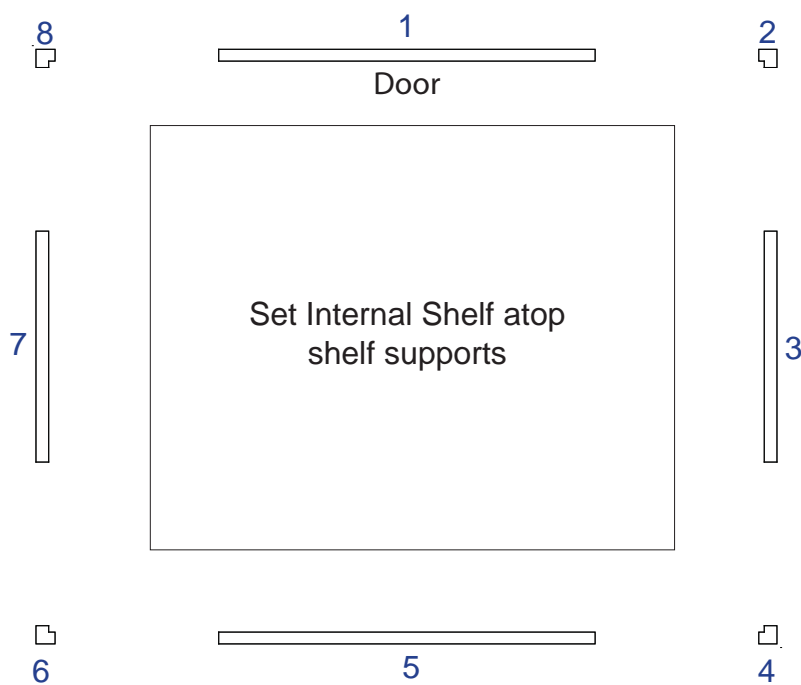

Modul Extrusion - Part List

Item Number	Description
A	44.423" Formed Extrusion
B	44.423" Formed Extrusion
C	22.23"w Horizontal Extrusion
D	22.23"w Horizontal Extrusion

Steps:

- 5) Attach extrusion [D] between curved extrusions [A and B].
- 6) Slide graphic into frame.
- 7) Attach extrusion [C] between curved extrusions and atop insert.
- 8) Hook assembled frame with graphic attached to assembled Pedestal as shown.

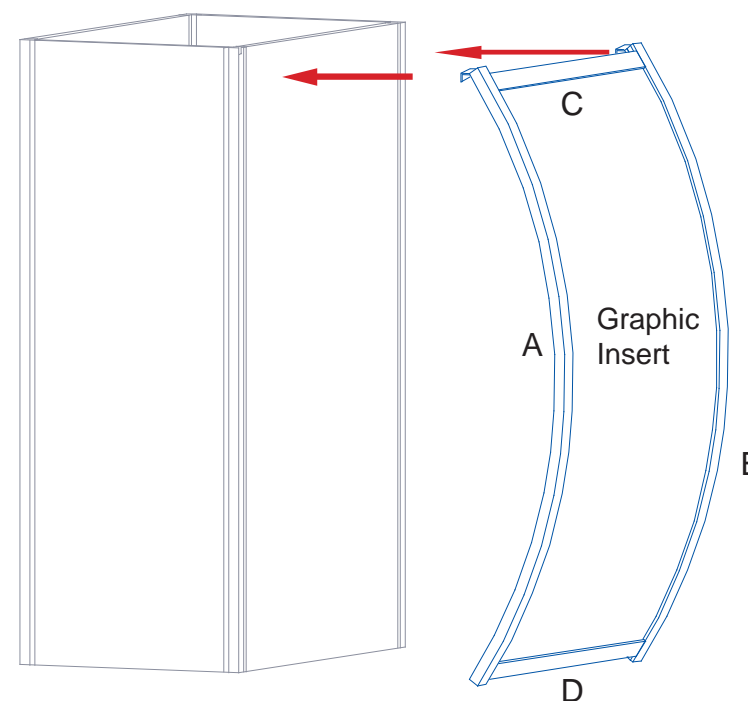

**\*\*NOTE:** Frame and graphic insert must stay assembled when shipping.

866.652.2100

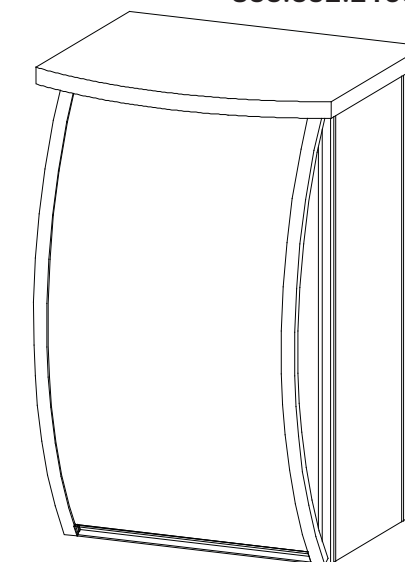

Steps:

- 9) Place Counter atop Assembled Pedestal

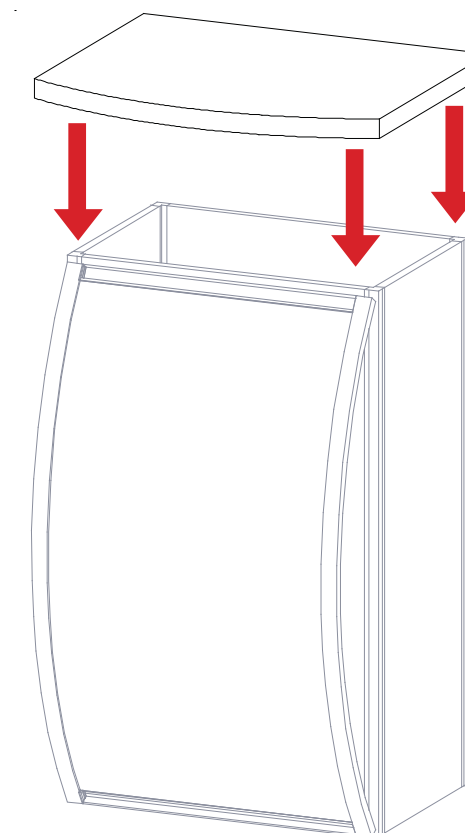

**WHEN DISASSEMBLING ALUMINUM EXTRUSION, TIGHTEN ALL SETSCREWS AND LOCKS TO PREVENT LOSS DURING SHIPPING**

