

WHEN DISASSEMBLING ALUMINUM EXTRUSION, TIGHTEN ALL SETSCREWS AND LOCKS TO PREVENT LOSS DURING SHIPPING

# visionary™ IDESIGNS

## Using Your Setup Instructions

The Visionary Designs Setup Instructions are created specifically for your configuration. They are laid out sequentially, including an exploded view of the entire display, and then a logical series of detailed steps to assemble the main structure and components. We encourage you to study the instructions **before** attempting to assemble your exhibit.

Each page reminds you to tighten the setscrews after disassembling your exhibit to prevent loss of the locks and setscrews (see below in RED). This is **VERY IMPORTANT**.

## Cleaning and Packing Your Display

- 1) Use care when cleaning aluminum extrusion or acrylic inserts. Use only non-abrasive cleaners.
- 2) When cleaning laminate inserts or countertops, use mild cleansers and a soft material such as cotton.
- 3) Keep all display components away from extreme heat and long exposure to sunlight to avoid warping and fading.
- 4) Retain all packing material. It will make re-packing much easier and will reduce the likelihood of shipping damage.



**The Tool**

Most Visionary Designs exhibits can be assembled with the supplied Hex Key Tool. Occasionally, a flat head screwdriver may be required.



Detail A

**Typical Connection**



**Typical Connection (cont'd)**

Most horizontal extrusion connections have a patented expandable lock. This lock inserts into the groove of an opposing extrusion. Tightening the lock with the Hex Key Tool expands the lock and creates a strong positive connection.



Detail B

**Numbered Label**

Each extrusion contains a numbered label which corresponds with setup instructions. The label is located within a groove of the extrusion (when possible). With Visionary Designs the labels contain Black numbers unless otherwise specified.



Detail C

**Horizontal Inline Connection** (remove only one setscrew)

Remove only (1) setscrew when disassembling. Replace setscrew in extrusion after assembling it. Before packing, replace setscrew in extrusion to avoid losing it.

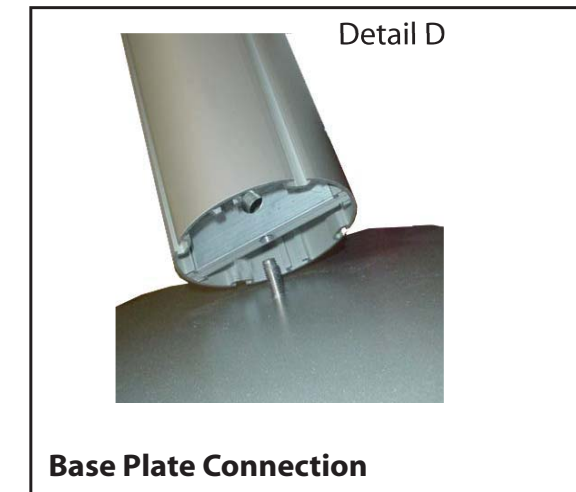

Detail D

**Base Plate Connection**

Attach base plate to round or square vertical extrusion using the bolt provided. Be careful not to strip the threads.



Detail E

**Vertical Connection**  
(remove only two setscrews)

When vertical extrusions are packed in portable cases rather than crates or tubs, they must be broken down into smaller sections which then require assembly.

Remove only (2) setscrews when disassembling. Replace setscrews in extrusion after assembling it. Before packing, replace setscrews in extrusion to avoid losing them.

**WHEN DISASSEMBLING ALUMINUM EXTRUSION, TIGHTEN ALL SETSCREWS AND LOCKS TO PREVENT LOSS DURING SHIPPING**

Item	Qty.	Description
1	3	Base Plate
2	1	42" h Vertical Extrusion
3	1	42" h Vertical Extrusion
4	1	45" h Vertical Extrusion w/ Door Stop
5	1	45" h Vertical Extrusion
6	1	45" h Vertical Extrusion w/ Door Hinges
7	1	45" h Vertical Extrusion
8a/8b	1/1	33" Horizontal Extrusion
9a/9b	1/1	33" Horizontal Extrusion
10a/10b	1/1	29.2099" Curved Horizontal Extrusion
11	1	44.7668" Vertical Extrusion
12a/12b	4/4	29.2099" Curved Horizontal Extrusion
13	1	45.2562" Vertical Extrusion

**Steps:**

- 1) Attach lower vertical extrusion [2, 4 and 6] to base plates [1].
- 2) Attach upper vertical extrusions to lower extrusions.
- 3) Connect horizontal extrusions together [8a to 8b and 9a to 8b].
- 4) Attach pins onto groove of extrusions, see Pin Attachment details.
- 5) Attach lower curve extrusions [10a and 10b] between vertical extrusions [4, 6 and 11] as shown.
- 6) Place infills between vertical extrusions as shown.
- 7) Repeat steps to complete alcove section.

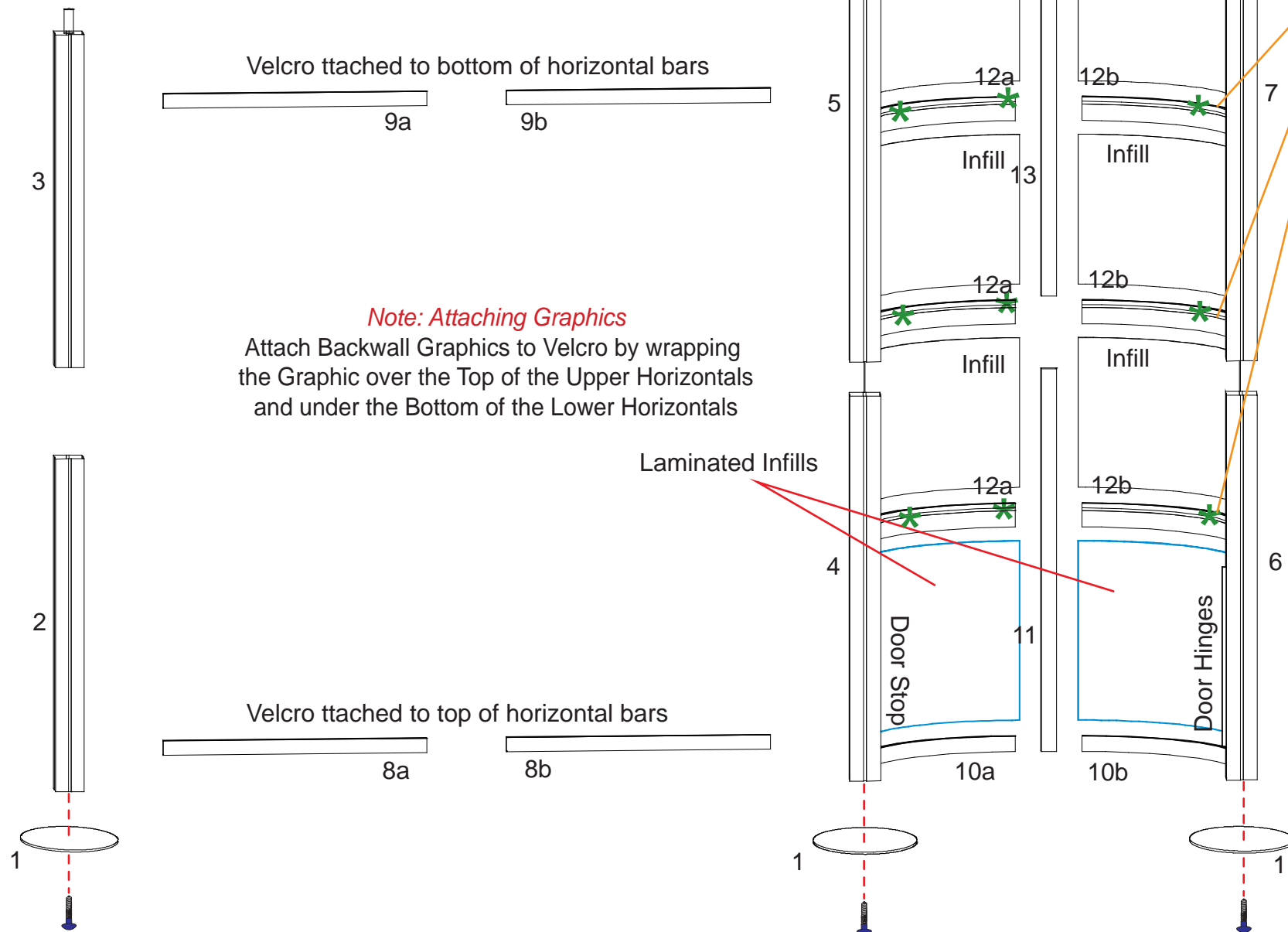
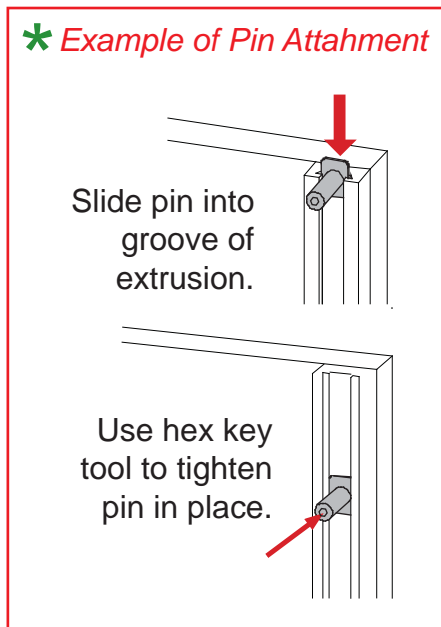

**Note:** Curved horizontal bars [12a and 12b] has groove on concave side. Position groove toward top.

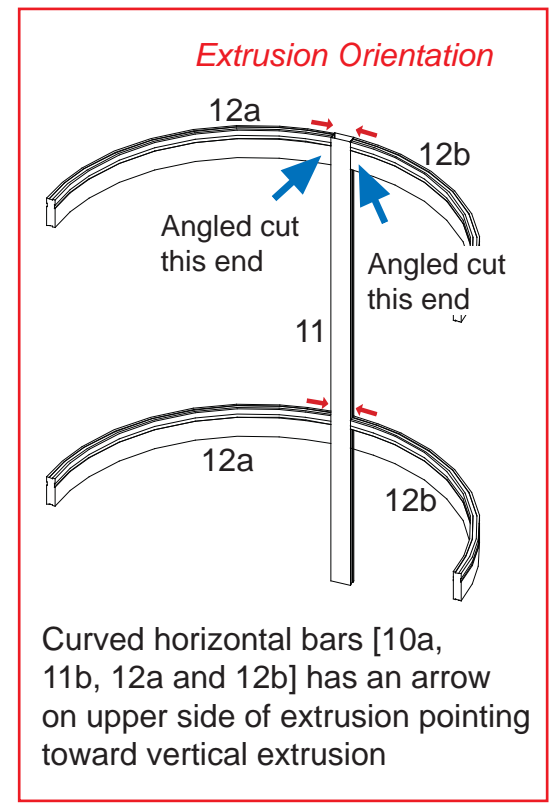

**Note: Attaching Graphics**  
Attach Backwall Graphics to Velcro by wrapping the Graphic over the Top of the Upper Horizontals and under the Bottom of the Lower Horizontals

**WHEN DISASSEMBLING ALUMINUM EXTRUSION, TIGHTEN ALL SETSCREWS AND LOCKS TO PREVENT LOSS DURING SHIPPING**

Item	Qty.	Description
14	2	34" w Horizontal Extrusion
15	1	34" w Horizontal Extrusion
16	1	34" w Horizontal Extrusion

Steps:

- 1) Attach lower horizontal extrusions [14] between vertical extrusions.
- 2) Attach door where indicated.
- 3) Attach horizontal extrusion [14] between vertical extrusions and atop door.
- 4) Attach horizontals [15 and 16] between vertical extrusions.  
*Note: horizontal bars must be at 8" from top of upper bar to bottom of lower bar.*
- 5) Place counter top atop pins and horizontal bar [14].
- 6) Place shelves and ceiling w/ puck lights atop pins.

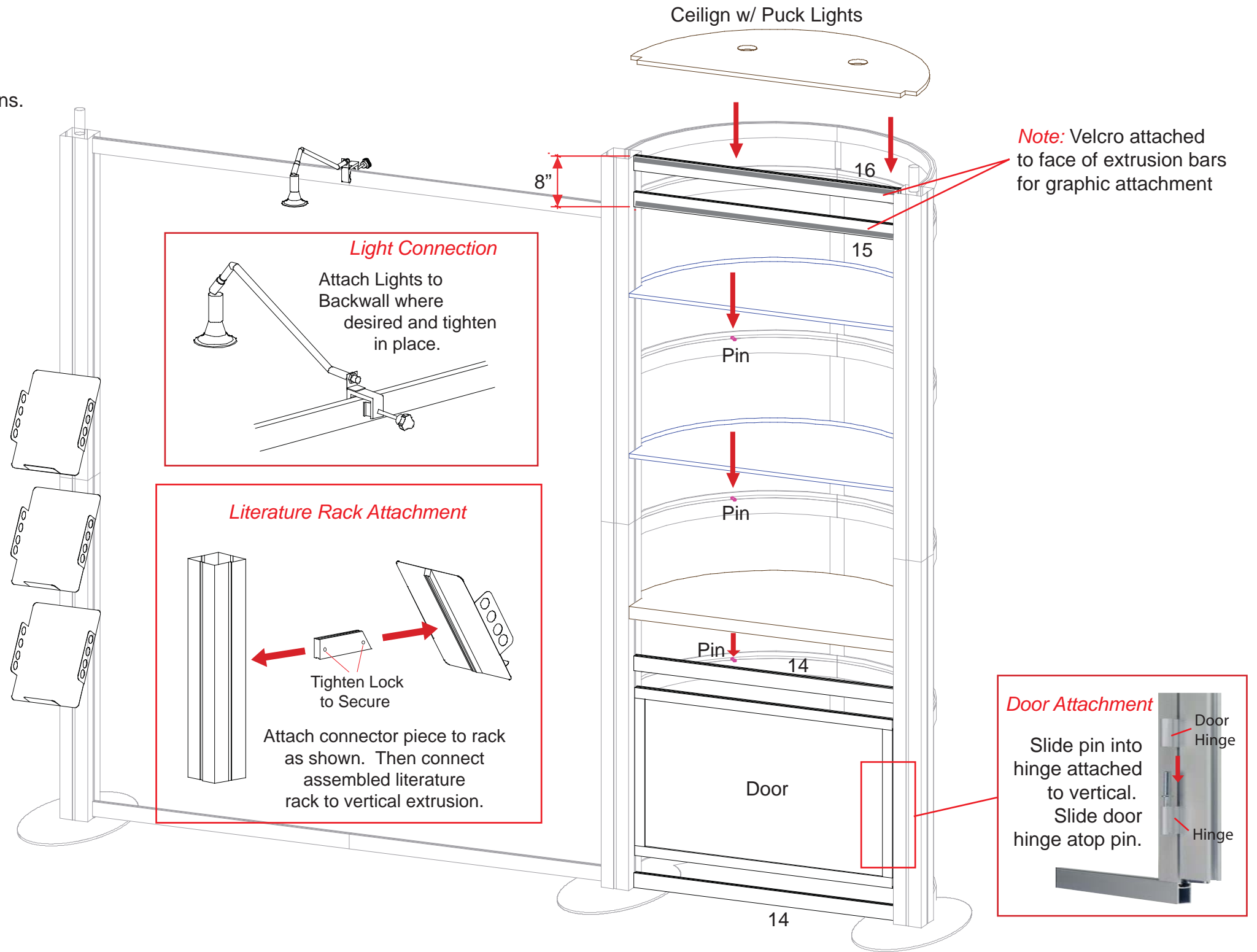
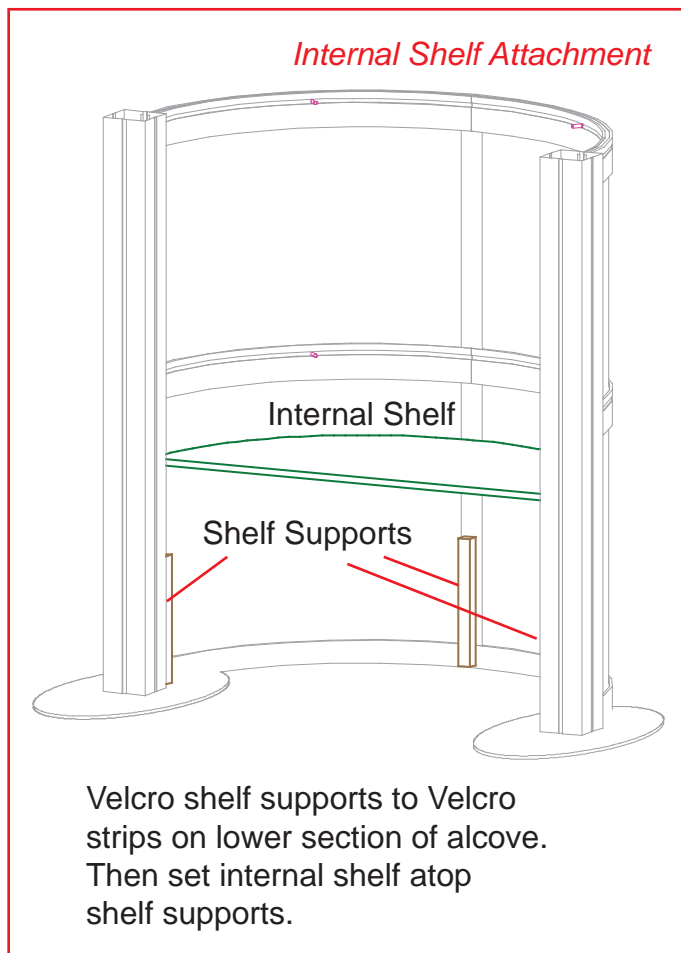

WHEN DISASSEMBLING ALUMINUM EXTRUSION, TIGHTEN ALL SETSCREWS AND LOCKS TO PREVENT LOSS DURING SHIPPING

# AERO

## Using Your Setup Instructions

The Aero Overhead Sign Setup Instructions are created specifically for your configuration. They include an exploded view of the frame which is sequentially numbered. We encourage you to study the instructions before attempting to assemble your exhibit.

Connections are kept very simple: no tools. Everything assembles with push-button connectors and pre-connected horizontal sections.

## Cleaning and Packing Your Display

- 1) Use care when cleaning aluminum extrusion or acrylic inserts. Use only non-abrasive cleaners.
- 2) Retain all packing material. It will make re-packing much easier and will reduce the likelihood of shipping damage.

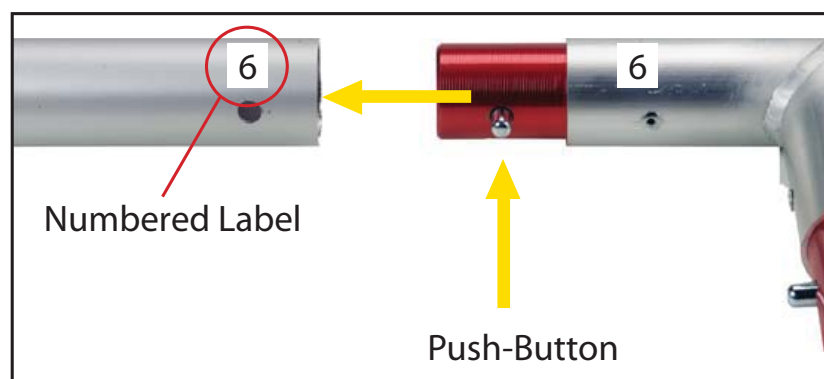

Connections are made by holding the button down and sliding the red tube into opposing tube until the connection is made. To disassemble push button and pull or twist extrusions apart.

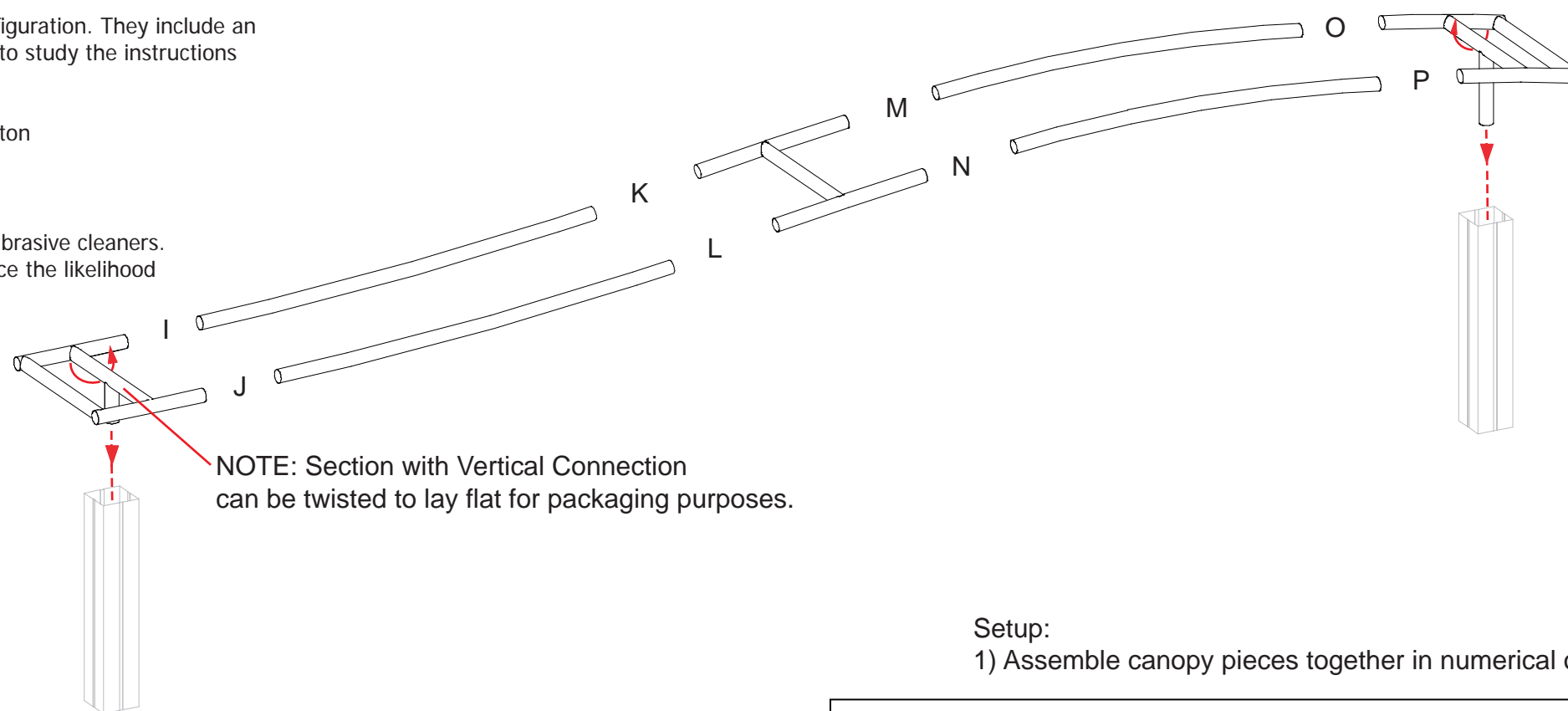
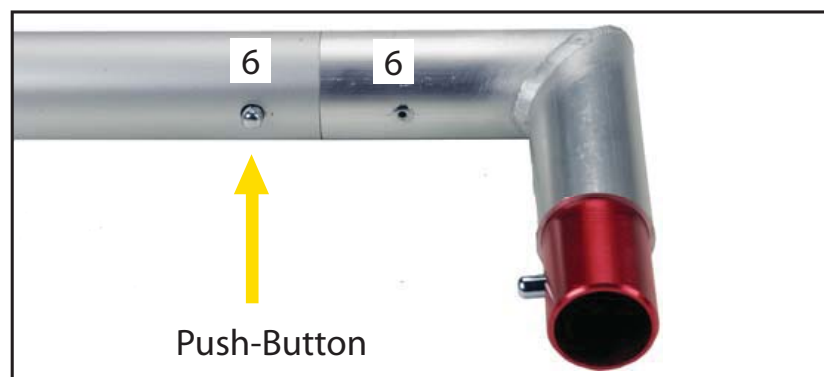

Setup:

- 1) Assemble canopy pieces together in numerical order.

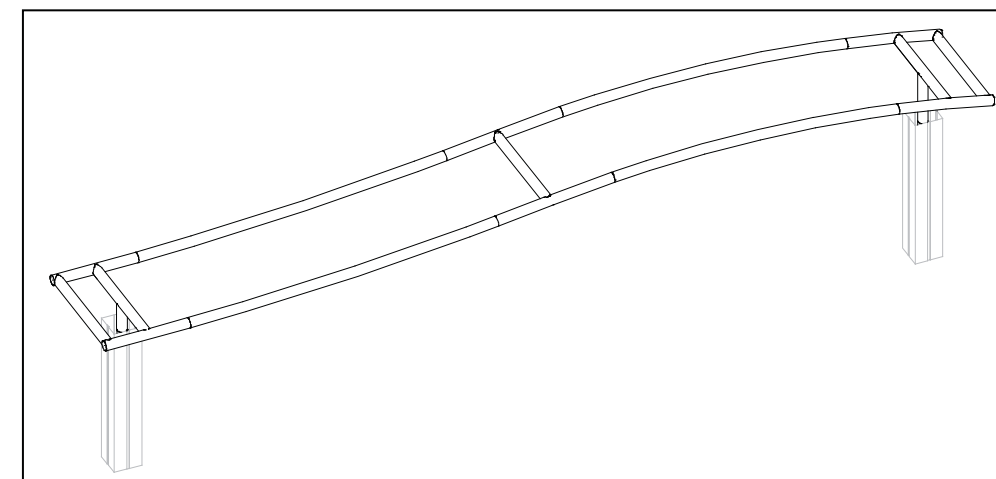

**WHEN DISASSEMBLING ALUMINUM EXTRUSION, TIGHTEN ALL SETSCREWS AND LOCKS TO PREVENT LOSS DURING SHIPPING**

866.652.2100

Item	Quantity	Description
17	1	38" h Vertical Extrusion
18	1	38" h Vertical Extrusion
19	1	38" h Vertical Extrusion
20	1	42" h Vertical Extrusion
20A	1	Plate for Counter Connection
21/21a	2/2	20" w Horizontal Extrusion
22	2	8.5" w Horizontal Extrusion
23	2	20" w Horizontal Extrusion
24	2	8.5" w Horizontal Extrusion
	4	Internal Shelf Support

Steps:

- 1) Connect horizontal extrusions [21A and 22] between vertical extrusions [17, 18, 19 and 20] resting atop stoppers at approximately 4" up from floor to bottom of metal.
- 2) Set floor in place atop lip of horizontal extrusions.
- 3) Place doors and inserts in place as shown.
- 4) Connect horizontal extrusions [23 and 24] between vertical extrusions [17, 18, 19 and 20] and atop inserts and door.
- 5) Velcro shelf supports to inside of pedestal, then set internal shelf atop supports.
- 6) Place counter atop assembled pedestal, attach [20A] to extrusion [3] then connect smaller counter to [20A].

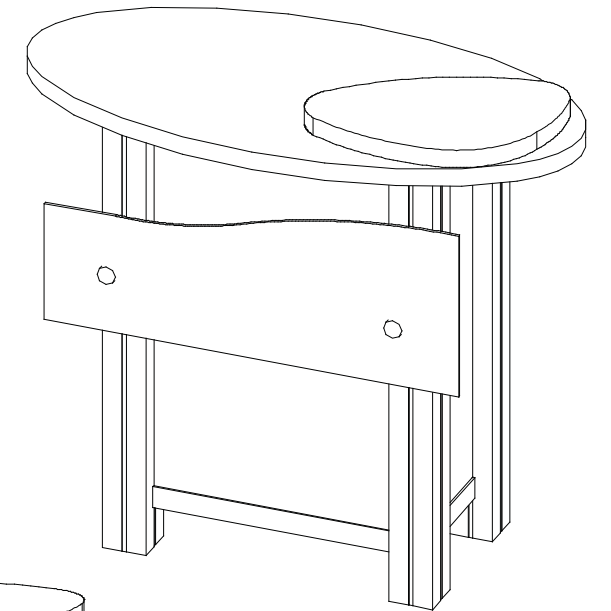

NOTE: TOP SIDE Label needs to be at top of round extrusion.

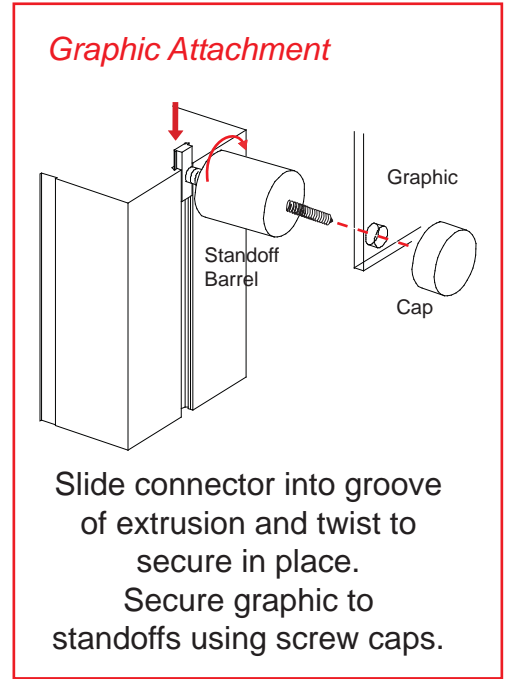
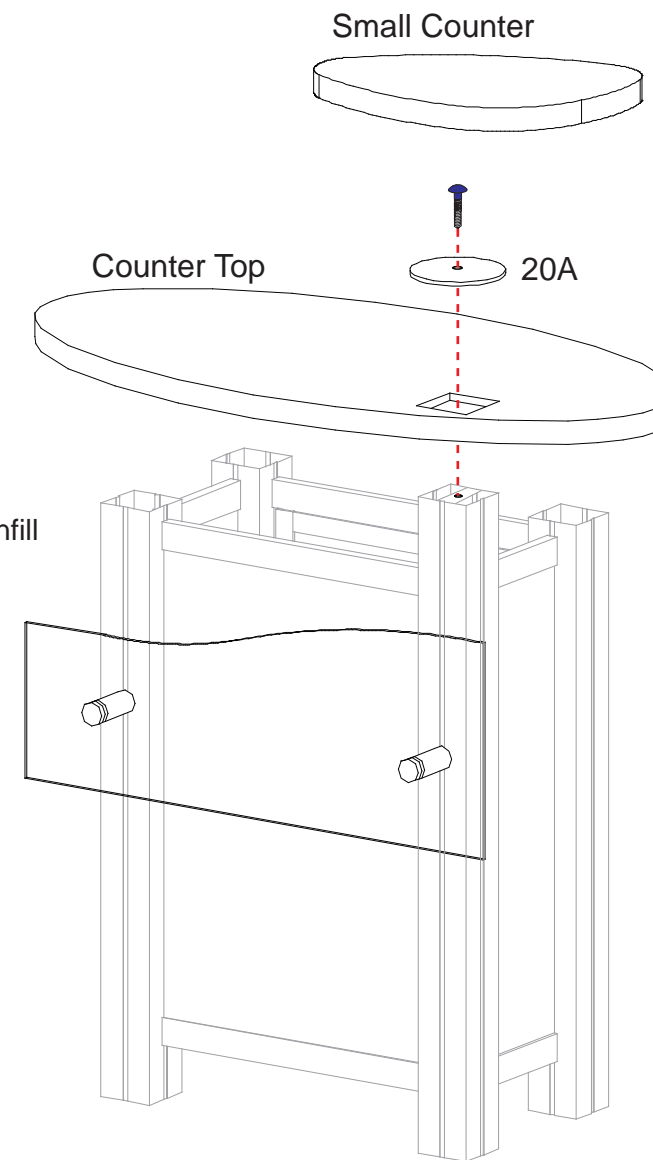
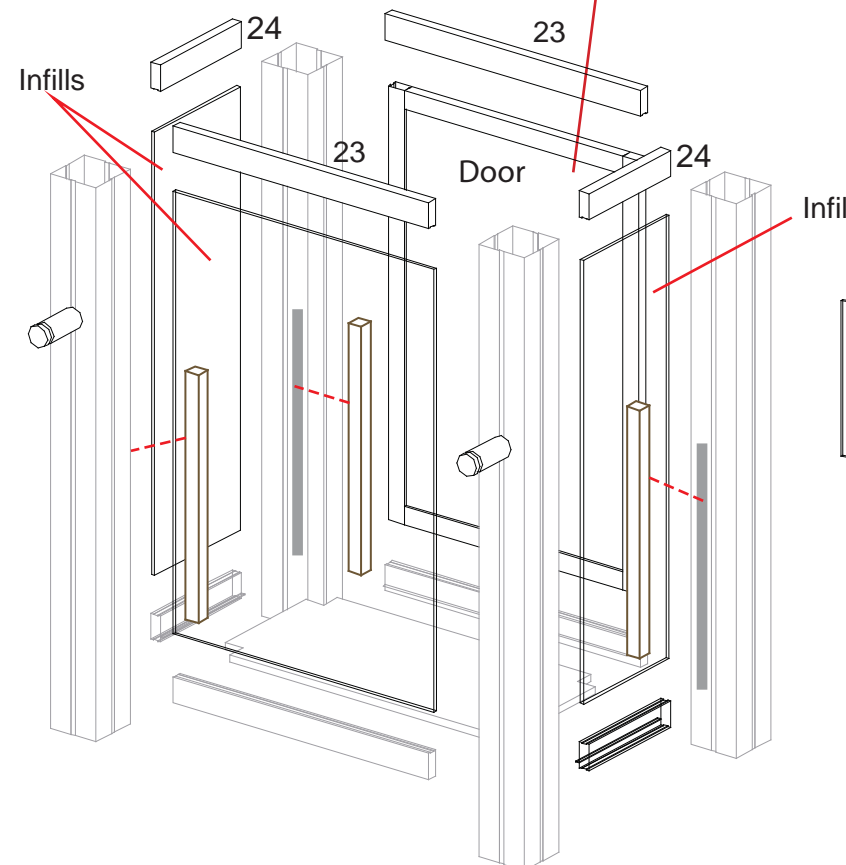
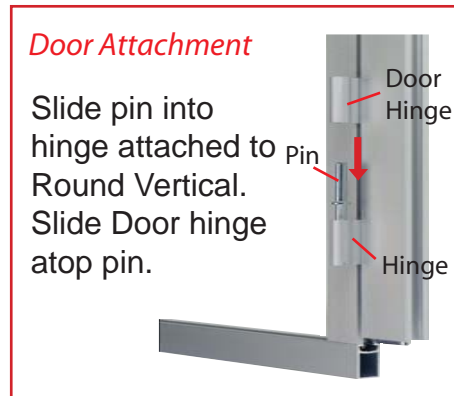
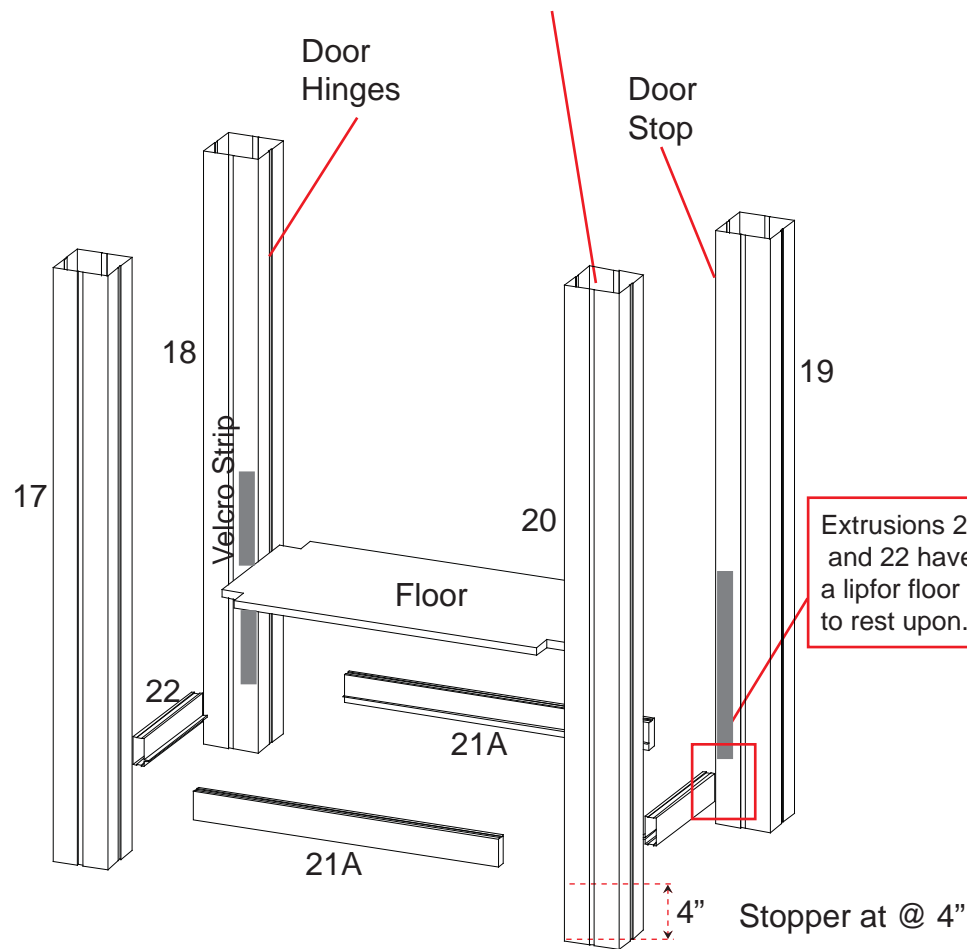

**WHEN DISASSEMBLING ALUMINUM EXTRUSION, TIGHTEN ALL SETSCREWS AND LOCKS TO PREVENT LOSS DURING SHIPPING**

Top View of Each Level

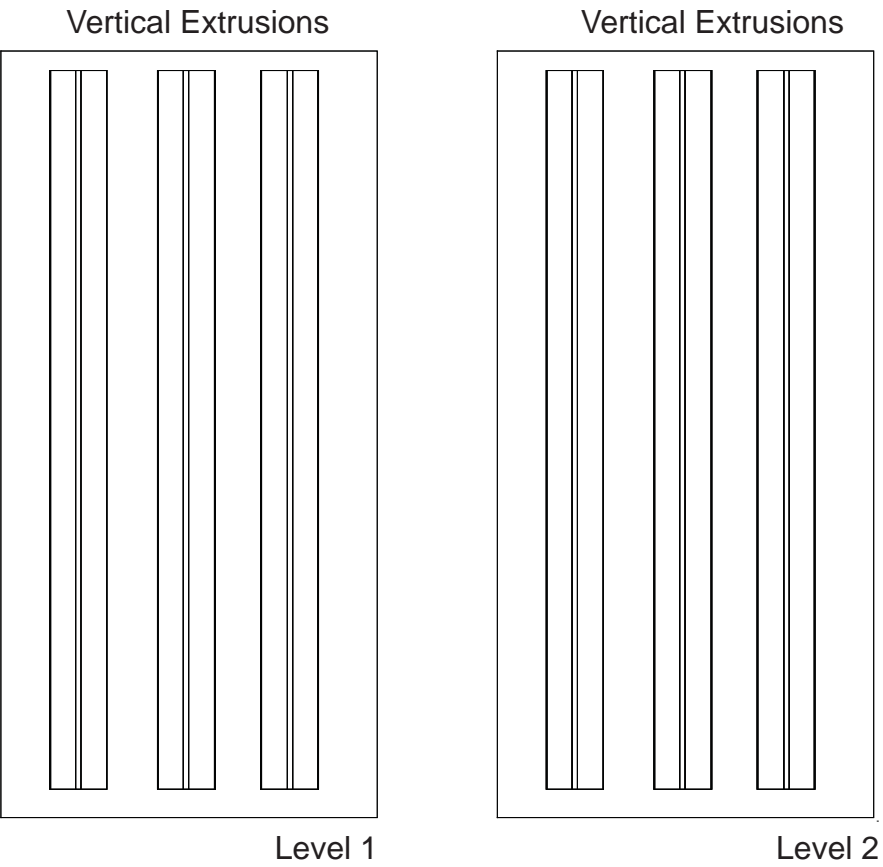

WHEN DISASSEMBLING ALUMINUM EXTRUSION, TIGHTEN ALL SETSCREWS AND LOCKS TO PREVENT LOSS DURING SHIPPING

Top View of Each Level

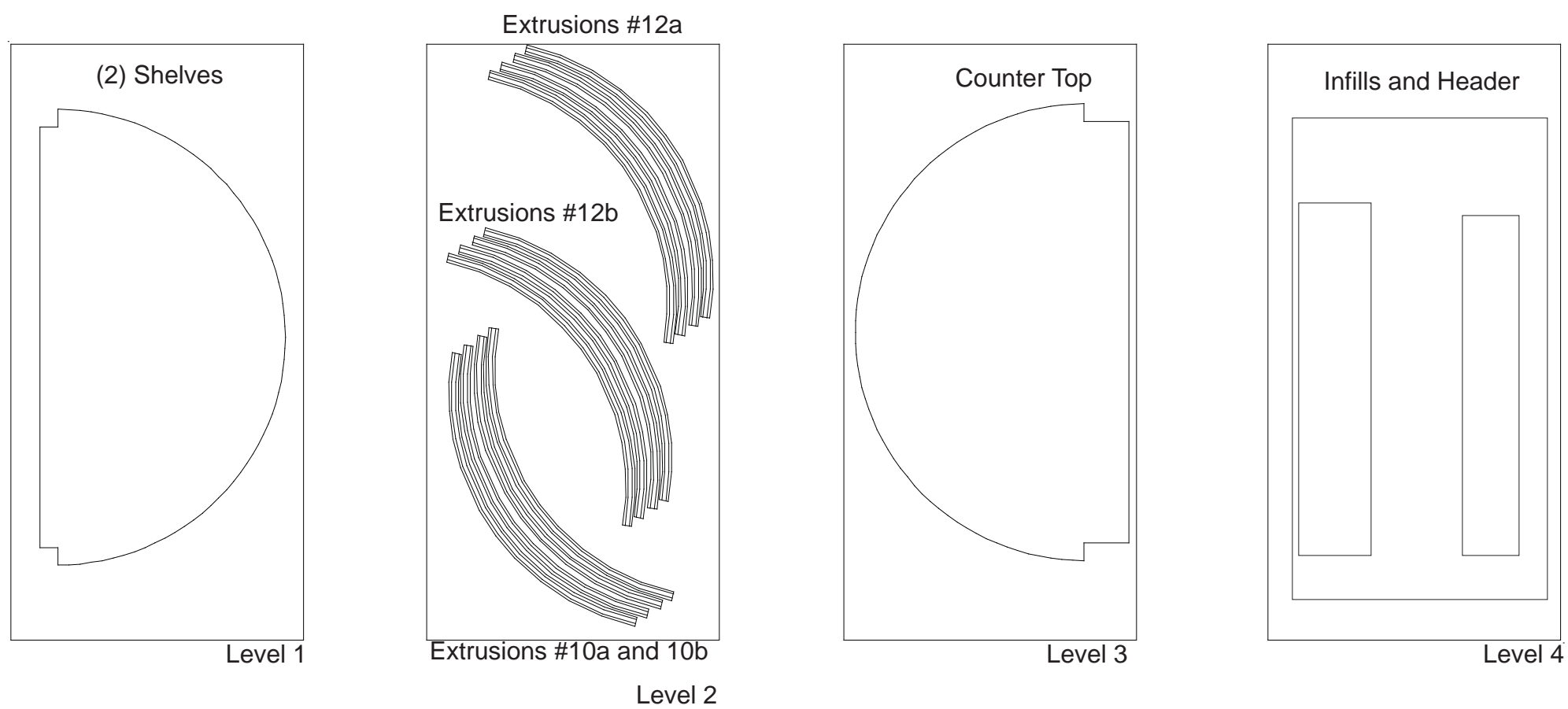

- Additional Items
- Box of (3) Bases
  - Box of Light
  - Box of (3) Literature racks

WHEN DISASSEMBLING ALUMINUM EXTRUSION, TIGHTEN ALL SETSCREWS AND LOCKS TO PREVENT LOSS DURING SHIPPING

Top View of Each Level

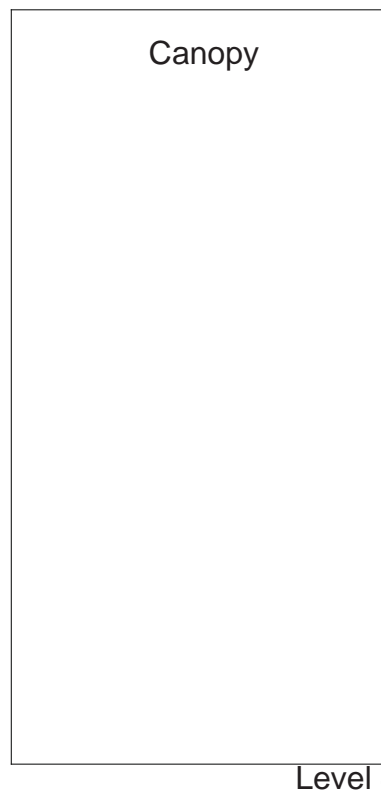
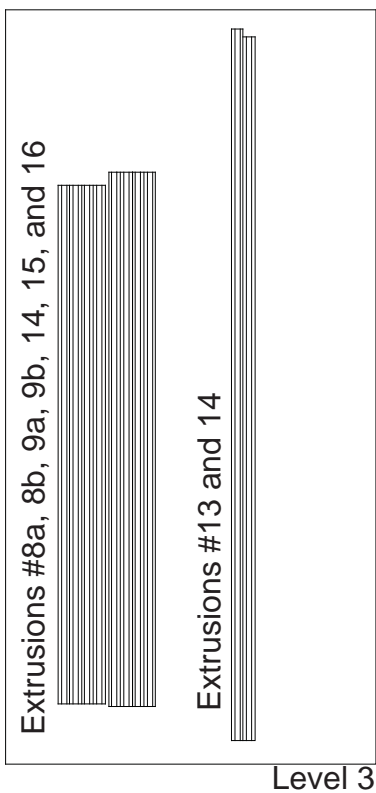
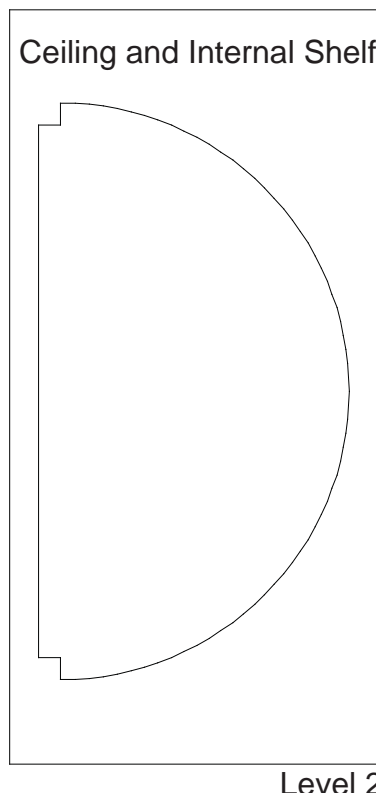
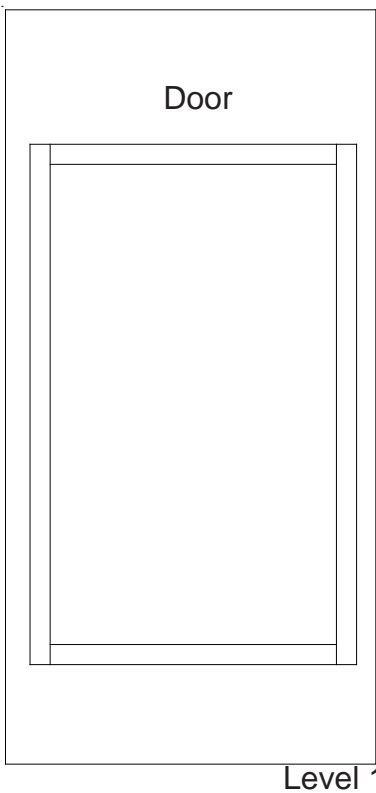

Additional Item  
- Setup Hardware

WHEN DISASSEMBLING ALUMINUM EXTRUSION, TIGHTEN ALL SETSCREWS AND LOCKS TO PREVENT LOSS DURING SHIPPING

Top View of Each Level

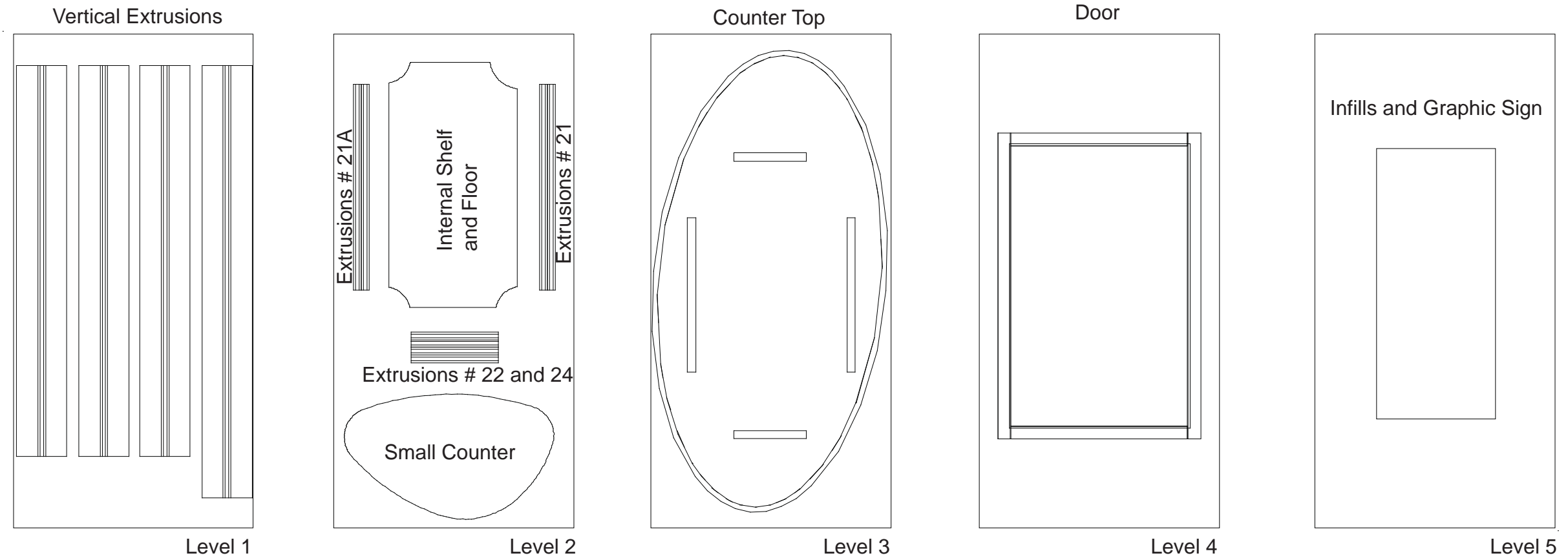

WHEN DISASSEMBLING ALUMINUM EXTRUSION, TIGHTEN ALL SETSCREWS AND LOCKS TO PREVENT LOSS DURING SHIPPING