

NOTE: WHEN DISASSEMBLING EXTRUSION TIGHTEN ALL LOCKS TO PREVENT LOSS OF SETSCREWS

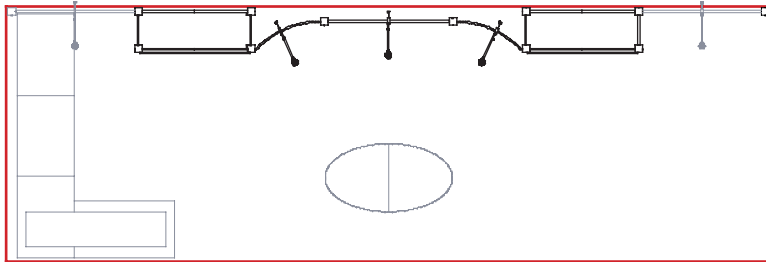

Item	Quantity	Description
1	8	47.5" Lower Square Vertical Extrusion
2	8	47.5" Upper Square Vertical Extrusion
3	2	47.5" Lower Square Vertical Extrusion
4	2	47.5" Upper Square Vertical Extrusion
5	4	14" Lower Horizontal Extrusion
6	4	14" Upper Horizontal Extrusion
7	2	24.75" Lower Horizontal Extrusion - Back Left
8	2	24.75" Lower Horizontal Extrusion - Back Right
9	2	24.75" Upper Horizontal Extrusion - Front Left
10	2	24.75" Upper Horizontal Extrusion - Front Right
11	2	24.75" Upper Horizontal Extrusion - Front Left
12	2	24.75" Upper Horizontal Extrusion - Front Right
13	2	24.75" Upper Horizontal Extrusion - Back Left
14	2	24.75" Upper Horizontal Extrusion - Back Right
15	2	33" Curved/Formed Horizontal Extrusion
16	2	33" Curved/Formed Horizontal Extrusion
17	2	28.5" Upper & Lower Horizontal Extrusion - Left
18	2	28.5" Upper & Lower Horizontal Extrusion - Right

Steps:

- 1) Attach Lower 47.5" Square Verticals [parts: 1] to Upper 47.5" Square Verticals [parts: 2].
- 2) Attach Lower 47.5" Square Verticals [parts: 3] to Upper 47.5" Square Verticals [parts: 4].
- 3) Attach all 24.75" Left and Right Horizontal extrusions together - [parts: 7 to 8 - - parts: 9 to 10 - - parts: 11 to 12].
- 3) Attach all Lower 14" Horizontal extrusions [parts: 5] to 95" Square Verticals [parts: 1 & 2 and 3 & 4].
- 4) Attach all Upper 14" Horizontal extrusions [parts: 6] to 95" Square Verticals [parts: 1 & 2 and 3 & 4].
- 5) Attach all Lower 49.5" Horizontals [parts: 7 & 8] between 95" Square Verticals [parts: 1 & 2].
- 6) Attach all Upper 49.5" Horizontals [parts: 9 & 10] between 95" Square Verticals [parts: 1 & 2 and 3 & 4].
- 7) Attach all Upper 49.5" Horizontals [parts: 11 & 12] between 95" Square Verticals [parts: 1 & 2 and 3 & 4].
- 8) Attach all Upper 49.5" Horizontals [parts: 13 & 14] between 95" Square Verticals [parts: 1 & 2 and 3 & 4].
- 9) Attach 33" Curved/formed Horizontal extrusions [part: 15] to 95" Square Verticals [part: 1 & 3].
- 10) Attach 33" Curved/formed Horizontal extrusion [part: 16] to 95" Square Verticals [parts: 2 & 4].
- 11) Attach all 28.5" Left and Right Horizontal extrusions together - [parts: 17 to 18].
- 12) Attach 57" Horizontal extrusions [parts: 17 & 18] between Square Verticals [parts: 1 & 2].

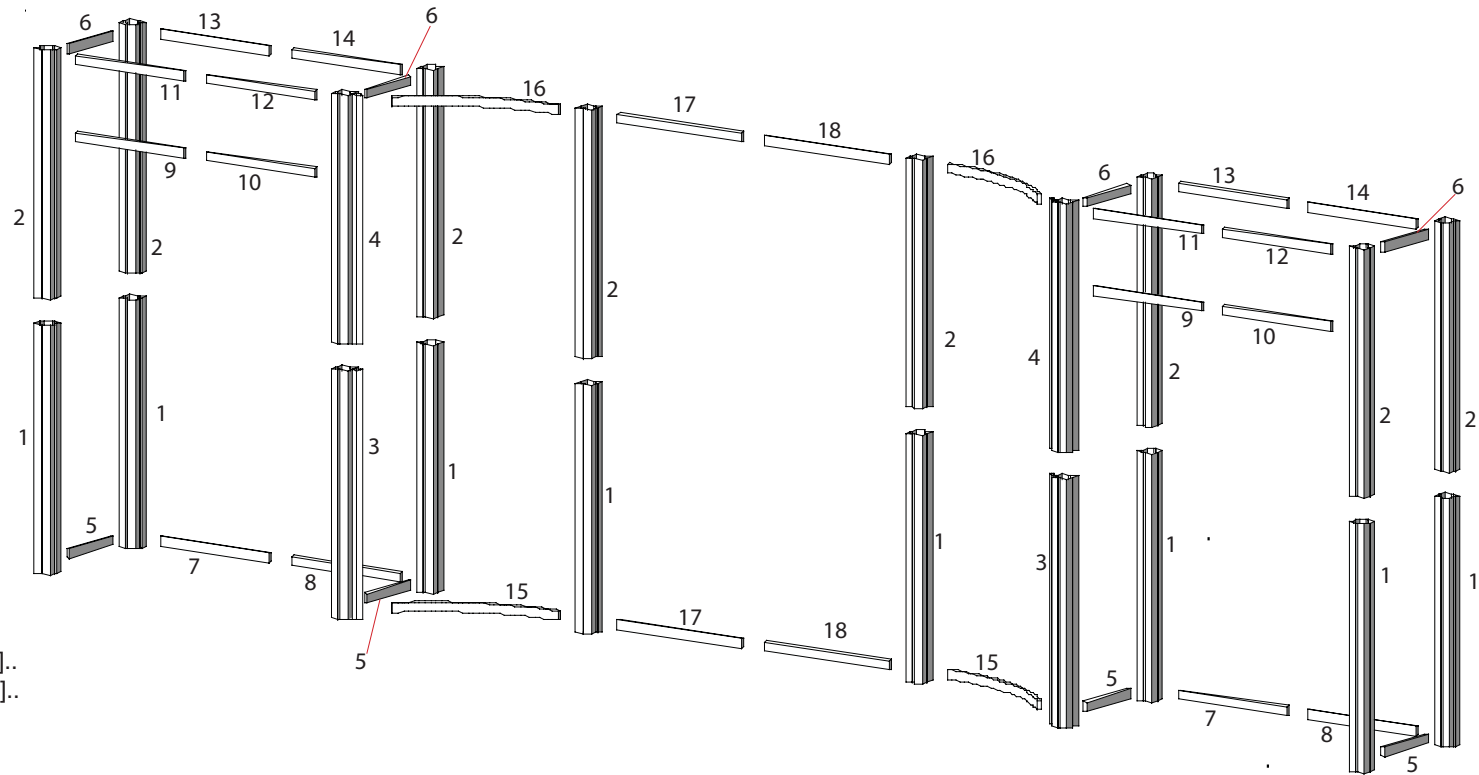

*** See next page for the Assembly of additional components to make up the 10x30 Configuration. ***

NOTE: WHEN DISASSEMBLING EXTRUSION TIGHTEN ALL LOCKS TO PREVENT LOSS OF SETSCREWS

Item	Quantity	Description
-	-	-
20	2	47.5" Lower Square Vertical Extrusion
21	2	47.5" Upper Square Vertical Extrusion
22	2	24.75" Lower Horizontal Extrusion - Left
23	2	24.75" Lower Horizontal Extrusion - Right
24	2	24.75" Upper Horizontal Extrusion - Left
25	2	24.75" Upper Horizontal Extrusion - Right
26	2	24.75" Horizontal Extrusion w/ Sliding door profile in Top Channel - Left
27	2	24.75" Horizontal Extrusion w/ Sliding door profile in Top Channel - Right
28	2	24.75" Horizontal Extrusion w/ Sliding door profile in Bottom Channel - Left
29	2	24.75" Horizontal Extrusion w/ Sliding door profile in Bottom Channel - Right

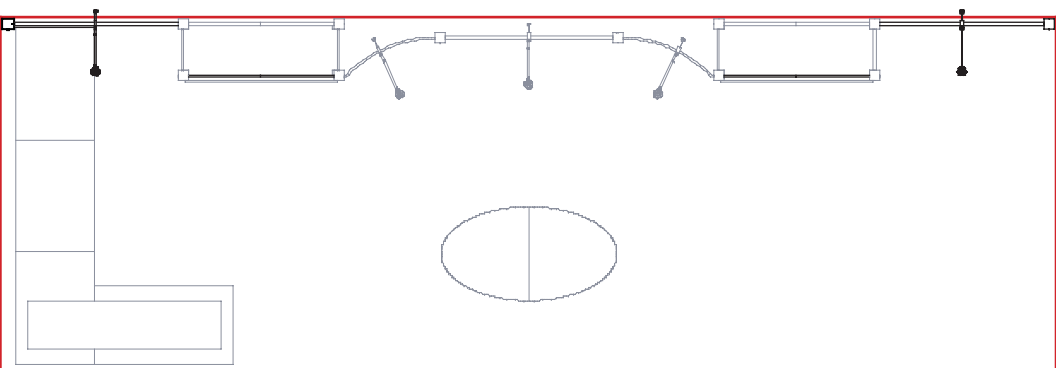

After Assembly of 10x20 Backwall -

Continued Steps for Additional components of the 10x30 Configuration:

- 13) Attach Lower 47.5" Square Verticals [parts: 20] to Upper 47.5" Square Verticals [parts: 21].
- 14) Attach all 24.75" Left and Right Horizontal extrusions together [parts: 22 to 23 - - parts: 24 to 25 - - parts: 26 to 27 - - parts: 28 to 29].
- 15) Attach all Lower 49.5" Horizontals [parts: 22 & 23] between 95" Square Verticals [parts: 1 & 2 and 20 & 21].
- 16) Attach all Upper 49.5" Horizontals [parts: 24 & 25] between 95" Square Verticals [parts: 1 & 2 and 20 & 21].
- 17) Attach all 24.75" Left and Right Horizontal extrusions w/ Sliding Door Profiles together [parts: 26 to 27 - - parts: 28 to 29].
- 18) Attach 49.5" Horizontal extrusions w/ Sliding Door Profile between the 95" Verticals [parts: 1 & 2 and 3 & 4].
 note: Place Laminated Door Inserts between the 49.5" Horizontals w/ Sliding Door Profile [parts: 26 & 27 and 28 & 29].
- 19) Attach all Counter Tops.
- 20) Attach Graphics, Signs and Lights.

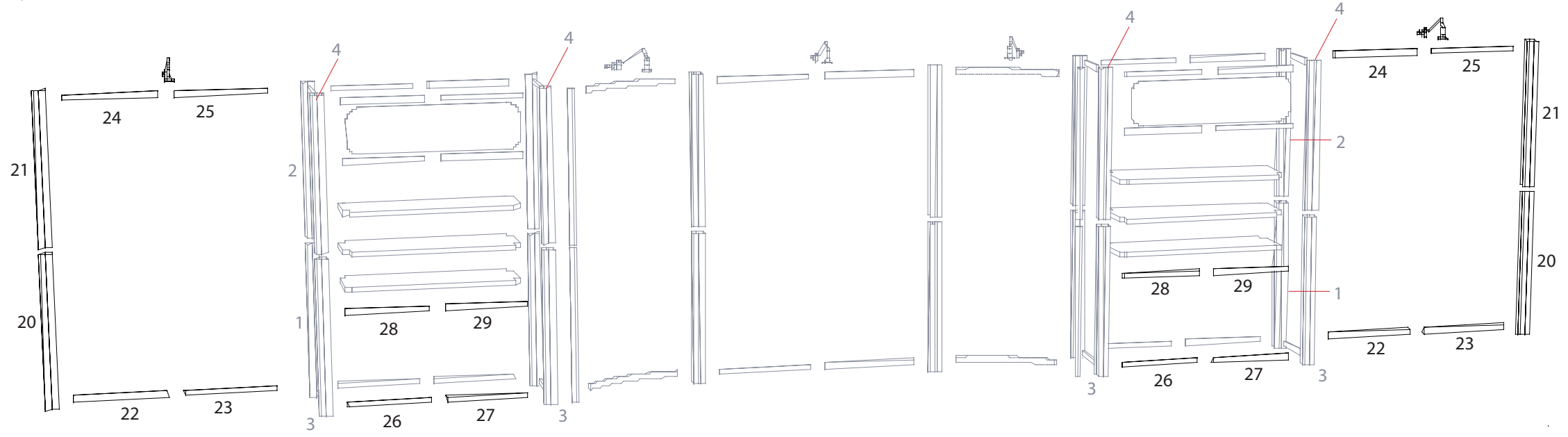

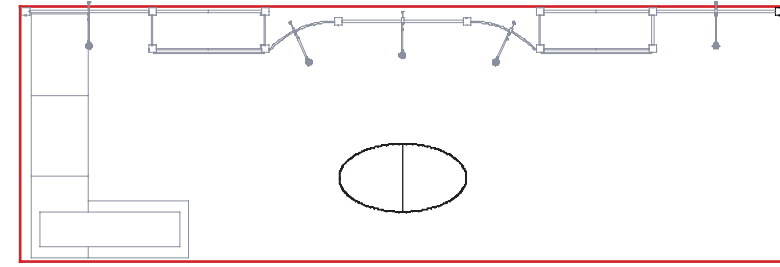
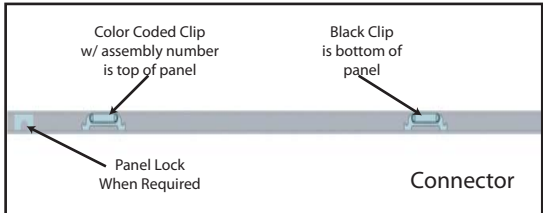
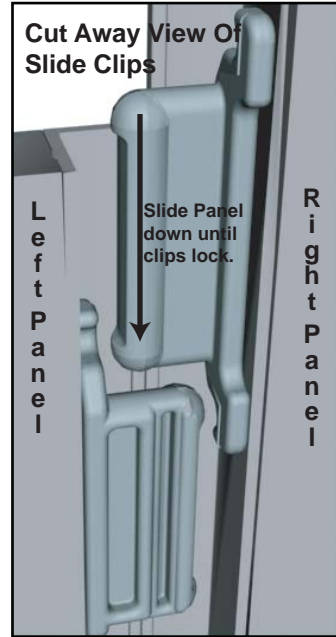
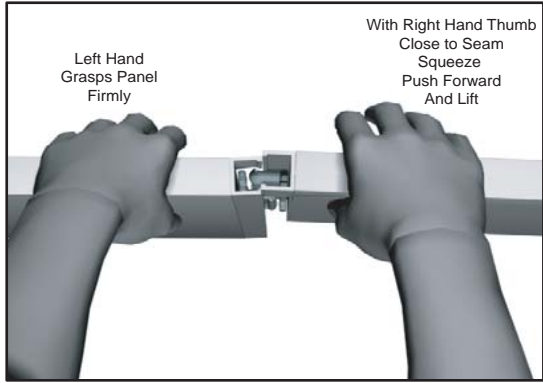

Attach Panels Together Using Standoff Caps

Attach Panels Together Using Standoff Caps

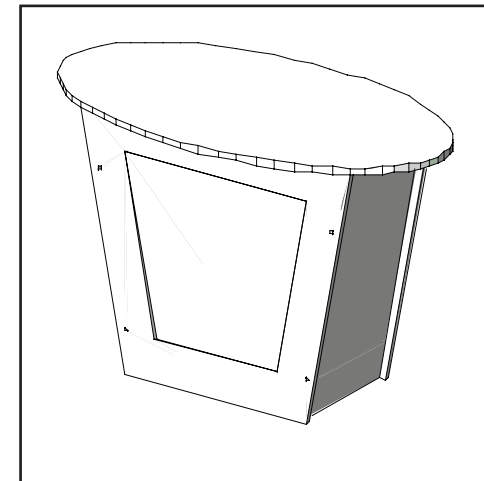
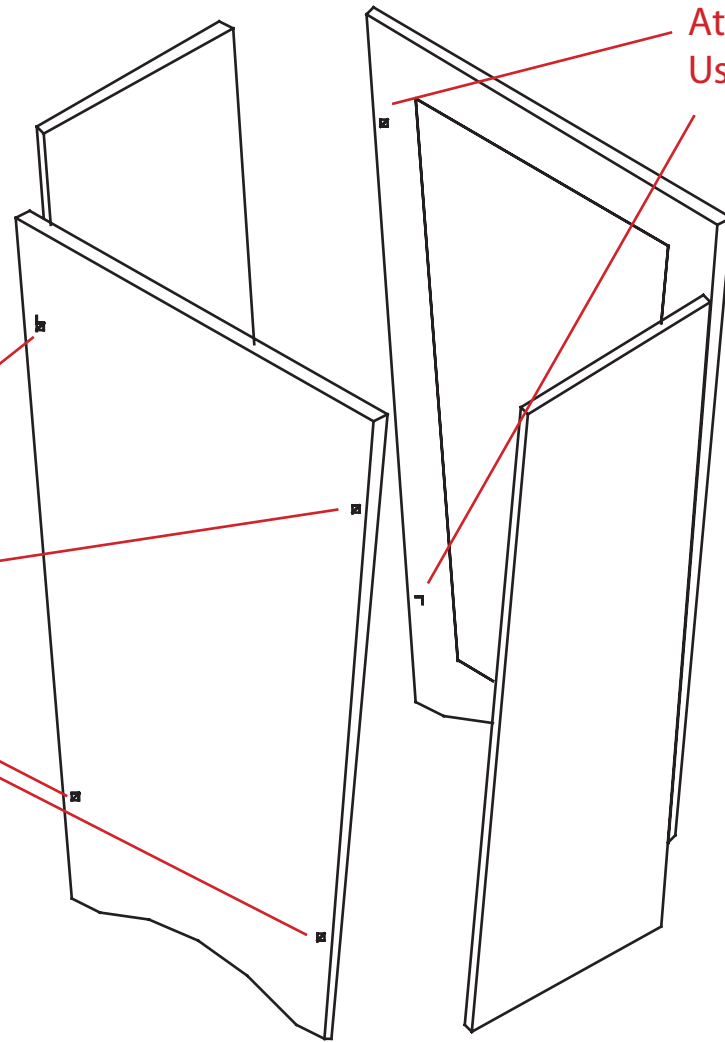

Option #1 - Custom LT L - Shaped Counter Unit - Order # 23286 page 4

Item Number	Quantity	Description
10	1	38" h 90° Connector
11	1	23" w x 38" h Flat Panel
12	1	38" h 90° Connector
13	1	46" w x 38" h Flat Panel w/ Large Door and Lock
14	1	Custom 40.5" w x 38" h Flat Panel w/ Large Door and Lock
15	1	38" h 90° Connector
16	1	46" w x 38" h Flat Panel w/ Large Door and Lock
17	1	38" h 90° Connector
18	1	23" w x 38" h Flat Panel
19	1	38" h 90° Connector
20	1	46" w x 38" h Flat Panel
21	1	Custom 24.5" w x 38" h Flat Panel
22	1	38" h 90° Connector
23	1	19" w x 38" h Flat Panel
24	1	46" w x 38" h Flat Panel
25	1	46" w x 38" h Flat Panel

- Steps:**
***** Use BLUE Labels. *****
- 1) Clip and attach all Lower Panels together [parts: 10 - 25].
 - 2) Attach 4-piece Counter top.
 - 3) Place and attach [8] Stand off supports for 2-piece Upper Counter Top.
 - 4) Attach 2-piece Counter Top using the [8] Stand offs placed in Step 3.

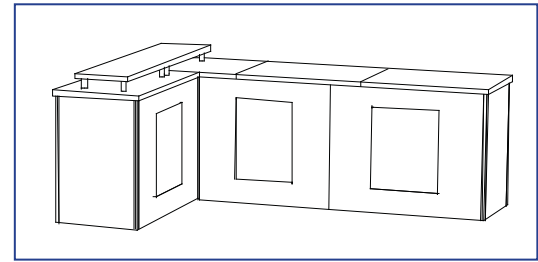
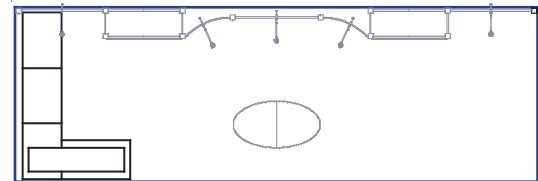
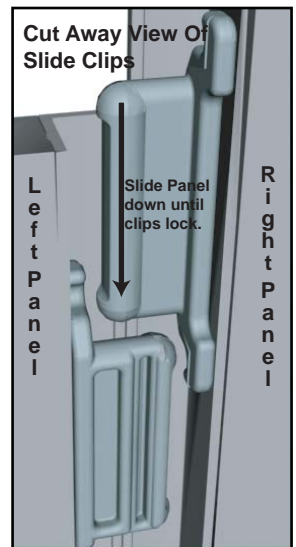
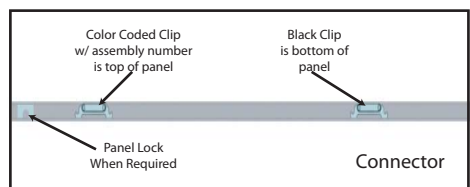
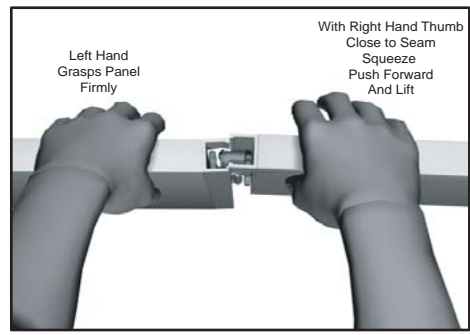
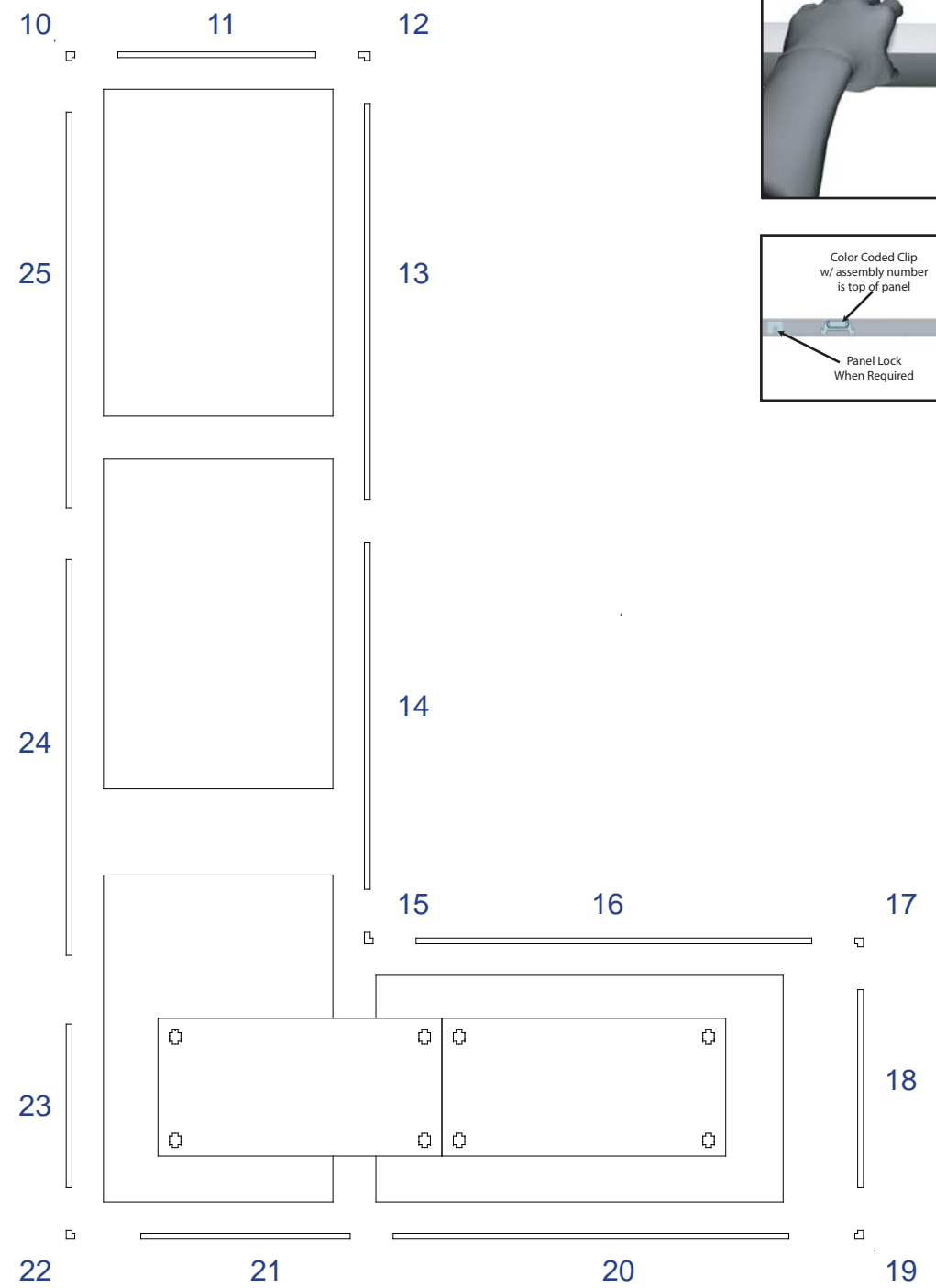
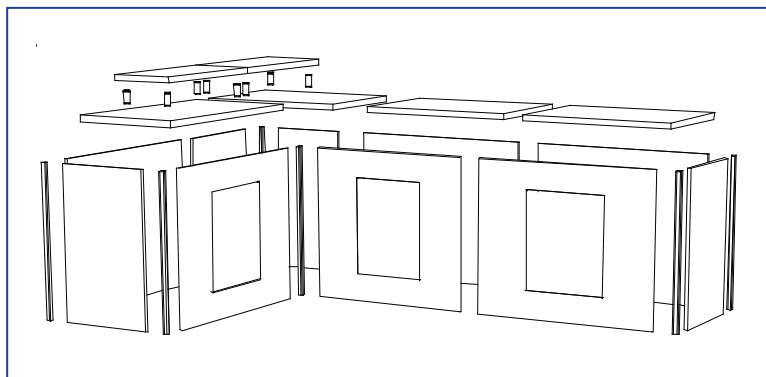

Option #2 - Custom LT U - Shaped Counter Unit - Order # 23286 page 5

Item Number	Quantity	Description
14	1	Custom 40.5"w x 38"h Flat Panel w/ Large Door and Lock
15	1	38"h 90° Connector
16	1	46"w x 38"h Flat Panel w/ Large Door and Lock
17	1	38"h 90° Connector
18	1	23"w x 38"h Flat Panel
19	1	38"h 90° Connector
20	1	46"w x 38"h Flat Panel
21	1	Custom 24.5"w x 38"h Flat Panel
22	1	38"h 90° Connector
23	1	19"w x 38"h Flat Panel
24	1	46"w x 38"h Flat Panel
25	1	46"w x 38"h Flat Panel
10	1	38"h 90° Connector
26	1	24.5"w x 38"h Flat Panel
27	1	46"w x 38"h Flat Panel
12	1	38"h 90° Connector
28	1	23"w x 38"h Flat Panel
29	1	38"h 90° Connector
30	1	46"w x 38"h Flat Panel w/ Large Door and Lock
31	1	38"h 90° Connector
32	1	21.5"w x 38"h Flat Panel

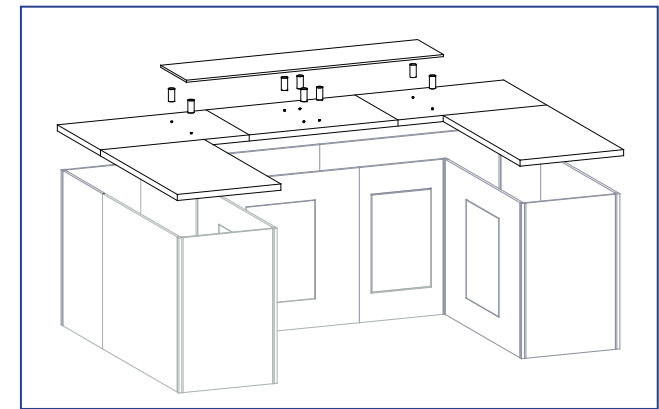
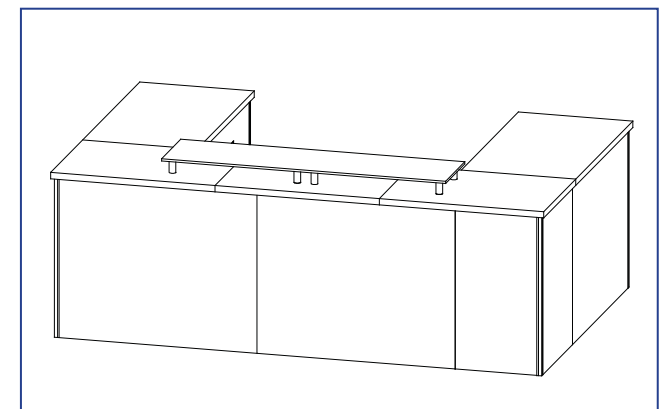
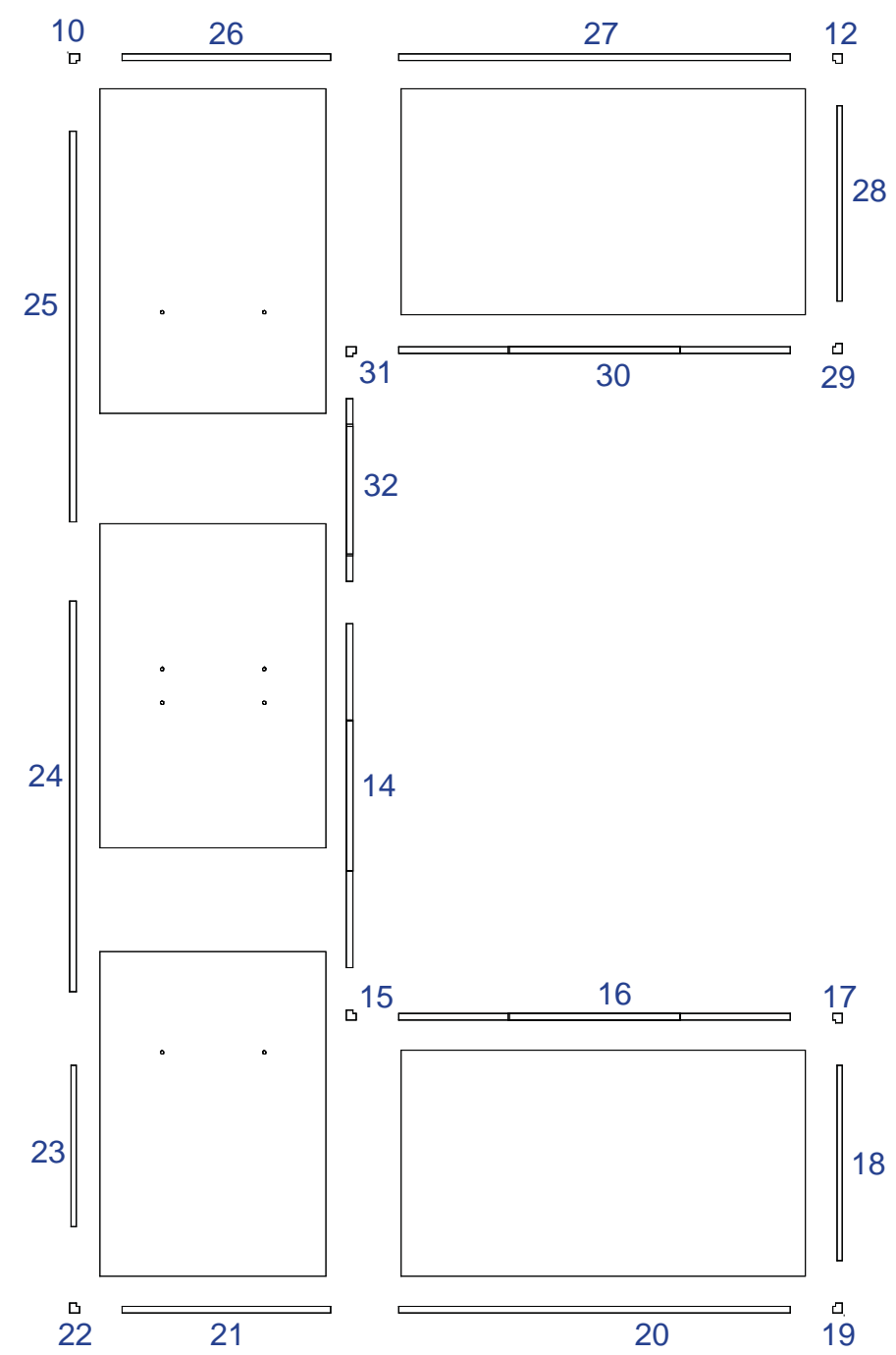

Steps:

*** Use BLUE Labels. ***

- 1) Clip and attach all Lower Panels together.
- 2) Place Counter Tops on Assembled Counter Base.
- 3) Place and attach [8] Stand off Barrels to Counter Top where indicated.
- 4) Attach Counter Top using the [8] Stand offs placed in Step 3.

