

# Perfect 10 Hybrid Displays

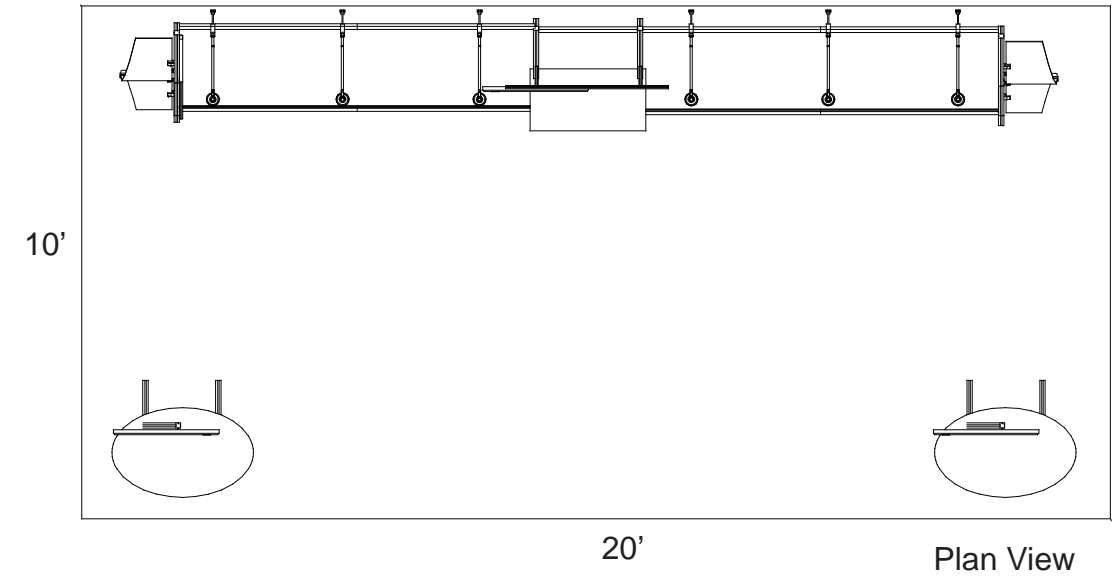
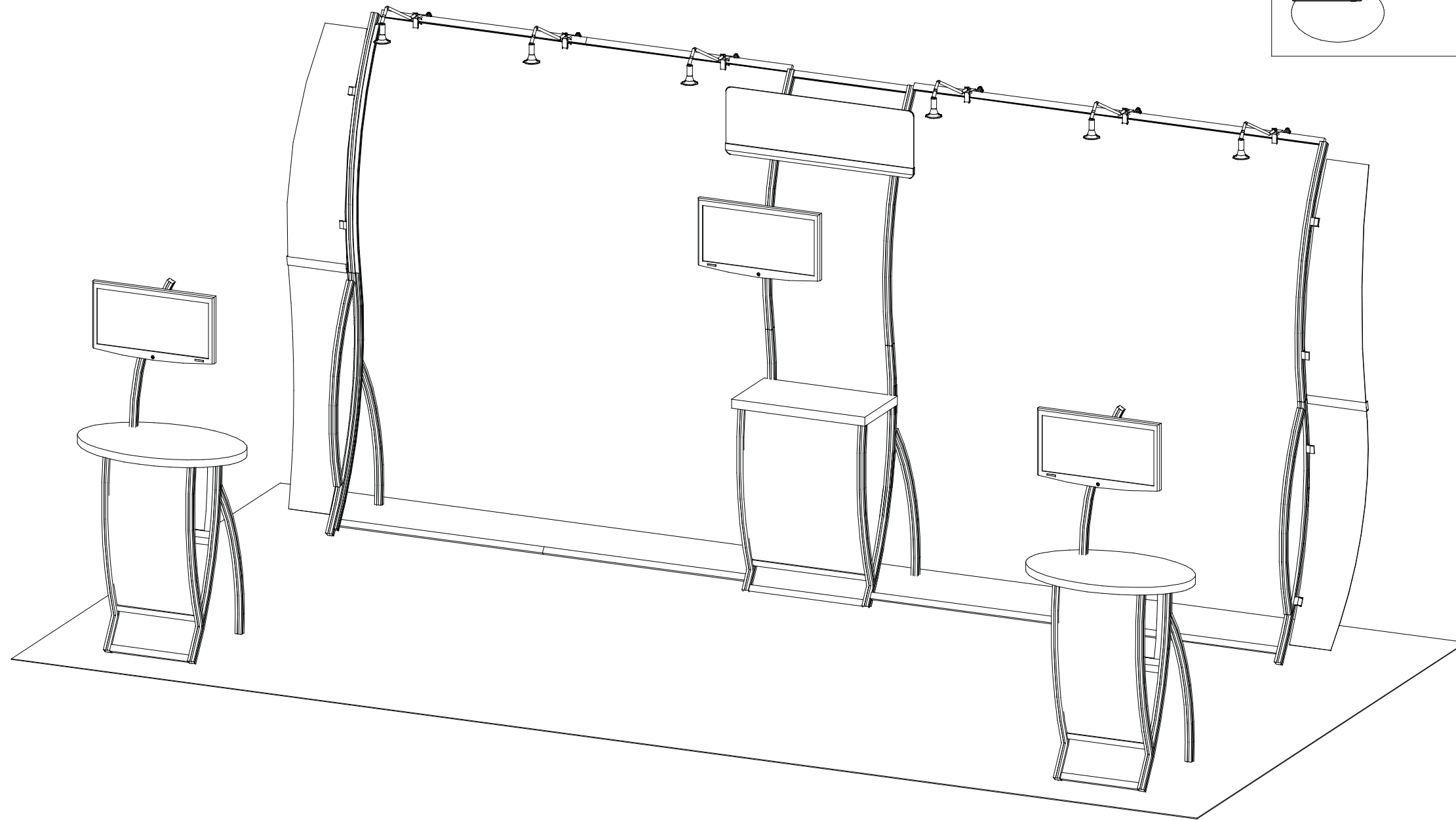

WHEN DISASSEMBLING TIGHTEN ALL KNOBS TO PREVENT LOSS DURING SHIPPING

Part Number	Description
1	Left Leg Assembly w/ Clamps Attached
2	Middle Leg Assembly
2A	Extrusion Assembly
3	Upper Curved Vertical
3A	Upper Curved Vertical Clamps Attached
4	83" w Horizontal
5	83" w Horizontal

NOTE: When assembling horizontals they should be placed approximately one inch from TOP and BOTTOM.

Step 1:

NOTE: Can be assembled either face down on floor then lifted upright or upright as shown in drawings.

- A) Connect vertical leg assemblies [1 and 2] together by connecting horizontal extrusions [4] between assemblies tightening BLACK knobs on backside of extrusion making sure Velcro faces toward BACK and placing it about one inch up from bottom and tightening.
- B) Connect vertical extrusions [3 and 3A] to leg assemblies [1 and 2] using vertical connection bar as shown.
- C) Connect upper horizontal extrusion [5] between verticals [3 and 3A] setting bar atop stopper, then attach lower horizontal extrusion [4].
- D) Connect extrusion assembly [2A] to leg assembly [2], placing insert as shown.

NOTE: Make sure the lock is flush with extrusion before tightening. If lock will not fully engage, gently rock lock and extrusion while turning knob until lock fully opens.

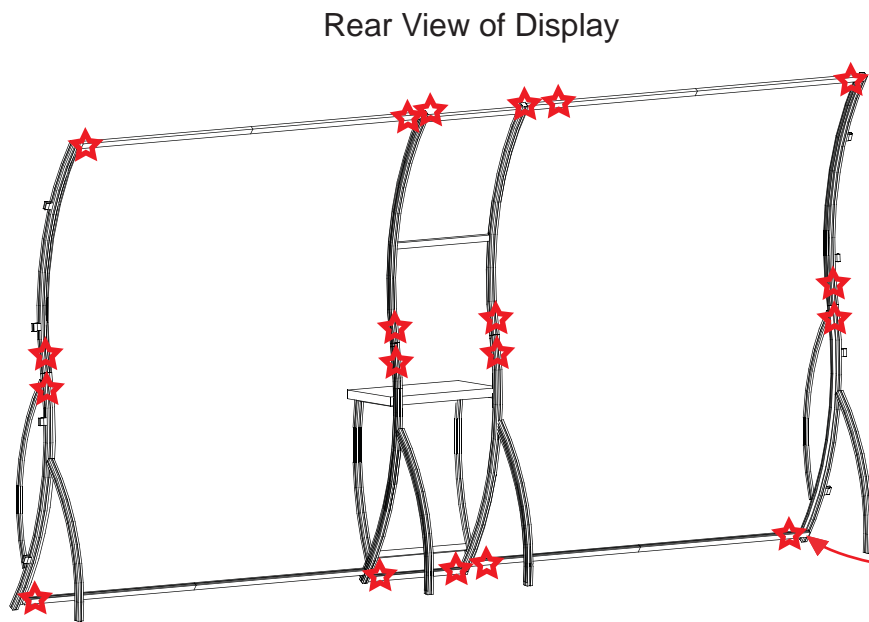
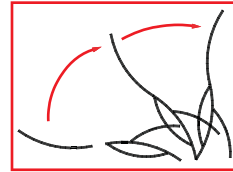

STAR indicates location of knobs on BACKSIDE of unit.

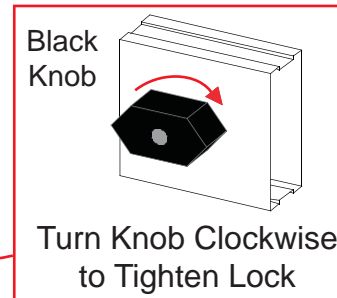

Step 1

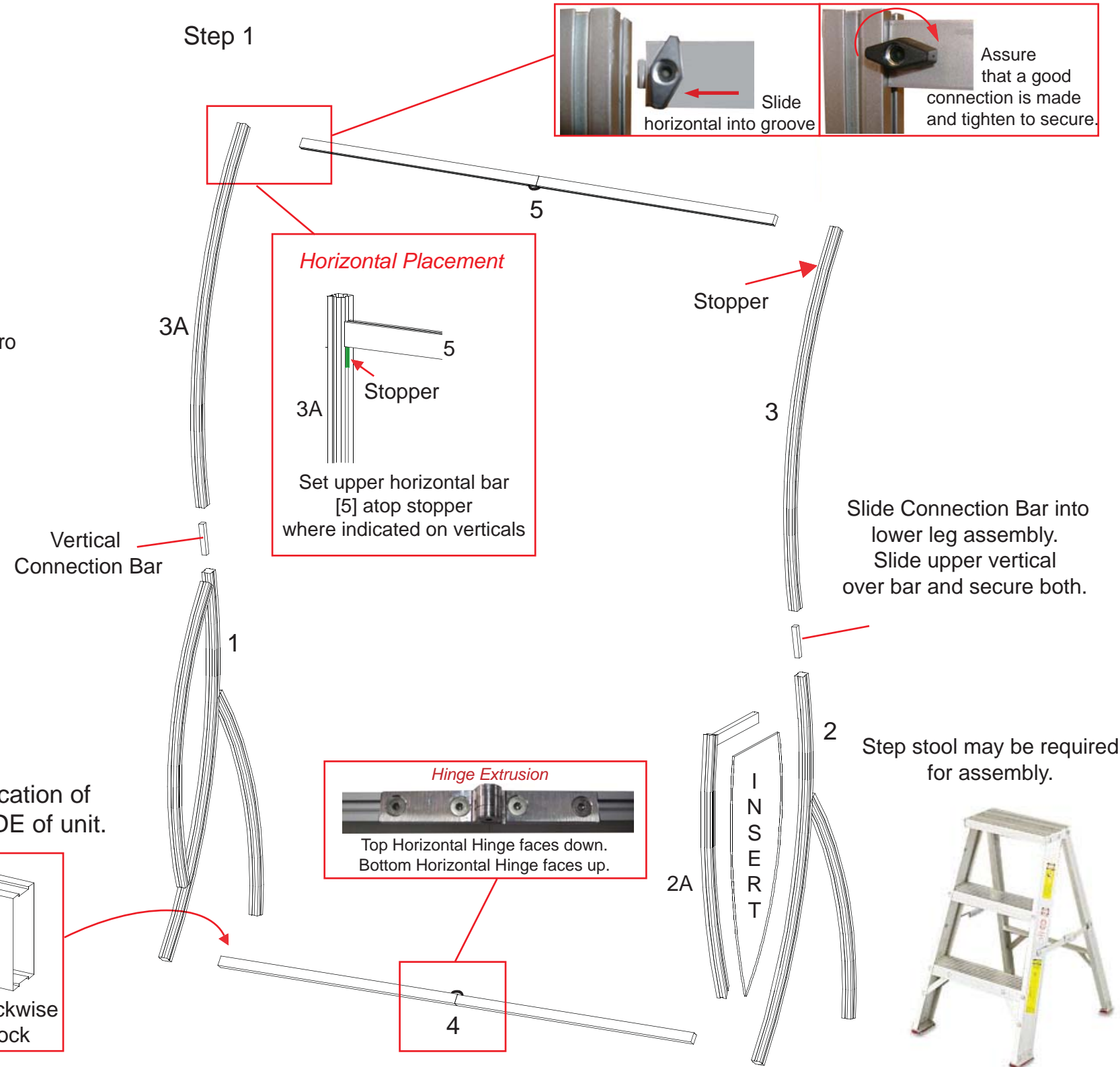

WHEN DISASSEMBLING TIGHTEN ALL KNOBS TO PREVENT LOSS DURING SHIPPING

866.652.2100

Part Number	Description
6	Leg Assembly
6A	Extrusion Assembly
7	Upper Curved Vertical
8	23" w Horizontal
9	23" w Horizontal for Monitor Mount Attachment

Step 2

NOTE: When assembling horizontals they should be placed approximately one inch from TOP and BOTTOM.

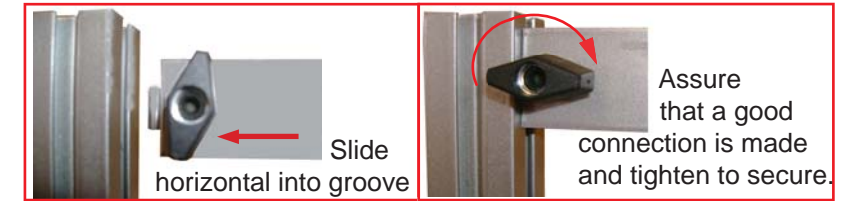

Step 2:

NOTE: Can be assembled either face down on floor then lifted upright or upright as shown in drawings.



- A) Connect vertical extrusion [7] to leg assembly [6] using vertical connection bar as shown.
- B) Connect horizontal extrusions [8 and 9] between vertical assemblies making sure Velcro faces toward BACK.
- C) Connect extrusion assembly [9A] to leg assembly [9], placing insert as shown.

NOTE: Make sure the lock is flush with extrusion before tightening. If lock will not fully engage, gently rock lock and extrusion while turning knob until lock fully opens.

Rear View of Display

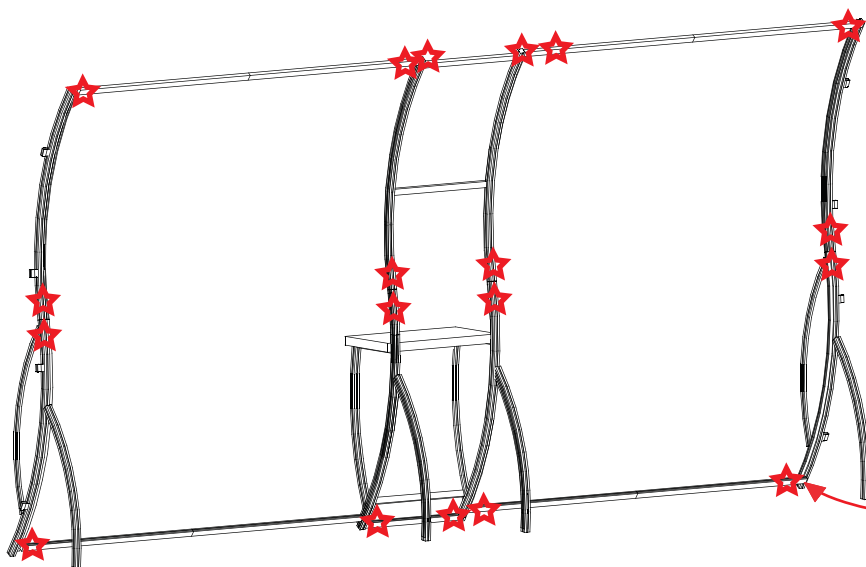

STAR indicates location of knobs on BACKSIDE of unit.

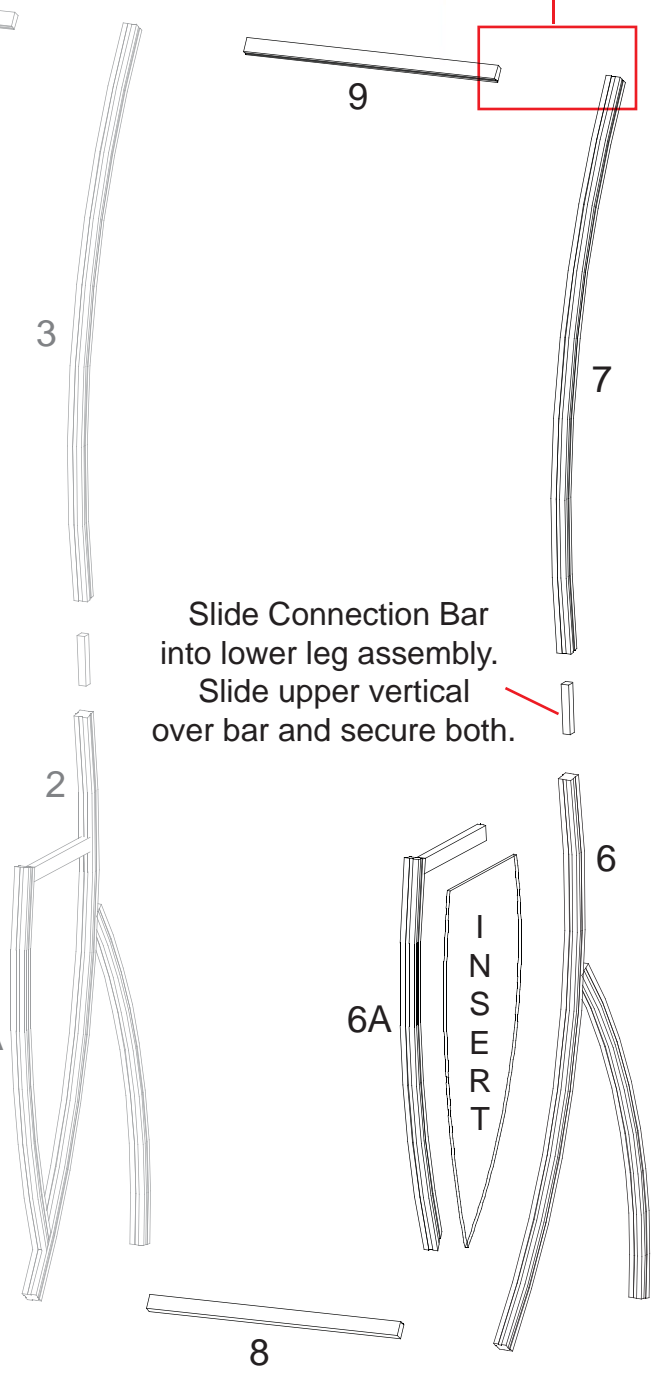
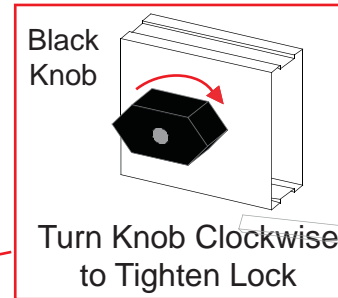

WHEN DISASSEMBLING TIGHTEN ALL KNOBS TO PREVENT LOSS DURING SHIPPING

Part Number	Description
11	23" w Horizontal

Step 3

Step 3:

- A) Attach horizontal extrusion [11] between vertical leg assemblies [2A and 6A].
- B) Insert laminated infill into grooves of vertical leg assemblies as shown.
- C) Attach horizontal extrusion [11] between vertical leg assemblies [2A and 6A] atop infill.
- D) Set counter top atop assembled workstation and secure with Velcro straps attached to underside of top.

**NOTE: Make sure the lock is flush with extrusion before tightening. If lock will not fully engage, gently rock lock and extrusion while turning knob until lock fully opens.**

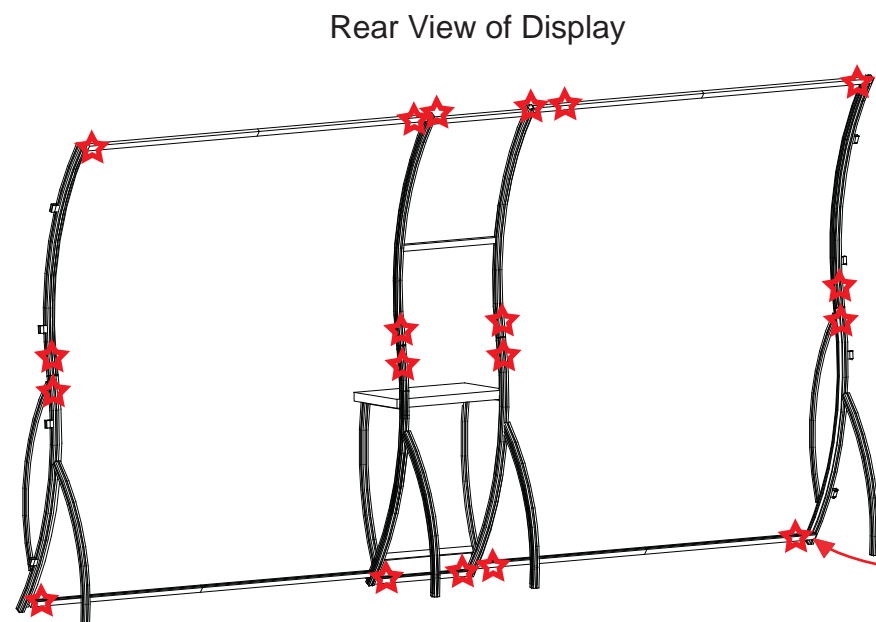

STAR indicates location of knobs on BACKSIDE of unit.

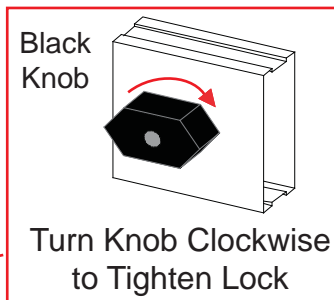

STAR indicates location of knobs on BACKSIDE of unit.

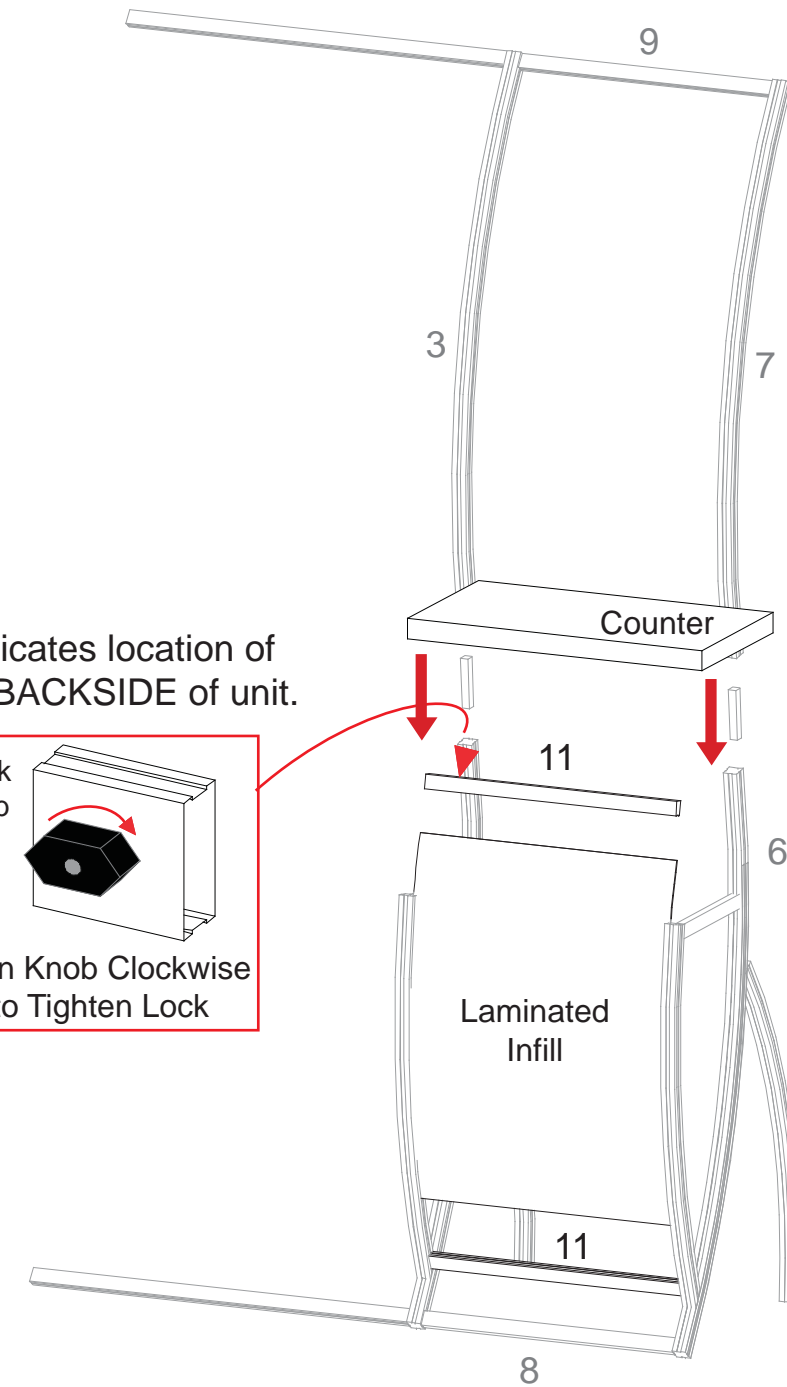
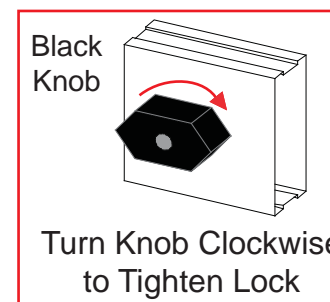

WHEN DISASSEMBLING TIGHTEN ALL KNOBS TO PREVENT LOSS DURING SHIPPING

866.652.2100

Part Number	Description
12	Leg Assembly
13	Upper Curved Vertical
14	83" w Horizontal w/ Hinge Facing UP
15	83" w Horizontal w/ Hinge Facing DOWN

Step 4

NOTE: When assembling horizontals they should be placed approximately one inch from TOP and BOTTOM.

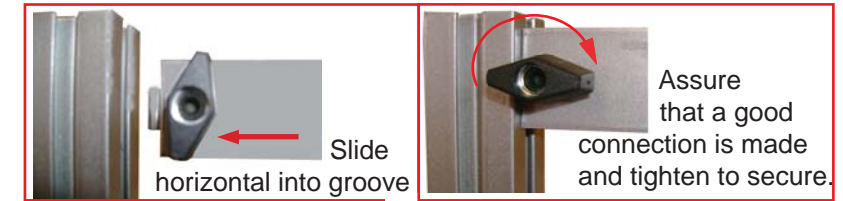

Step 4:

NOTE: Can be assembled either face down on floor then lifted upright or upright as shown in drawings.

- A) Connect vertical extrusion [13] to leg assembly [12] using vertical connection bar as shown
- B) Connect horizontal extrusions [14 and 15] between vertical assemblies by tightening BLACK knobs on backside of extrusion making sure Velcro faces toward BACK.

NOTE: Make sure the lock is flush with extrusion before tightening. If lock will not fully engage, gently rock lock and extrusion while turning knob until lock fully opens.

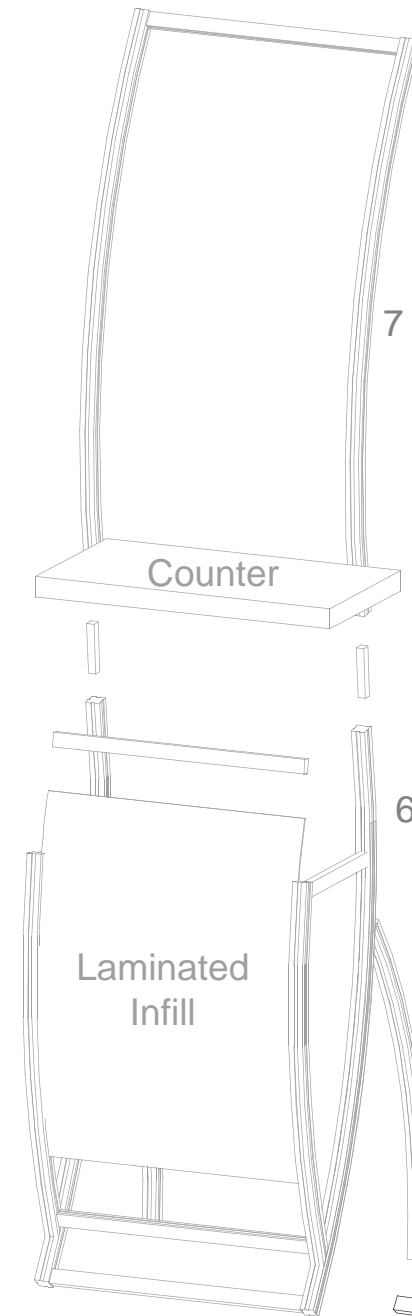

Slide Connection Bar into lower leg assembly. Slide upper vertical over bar and secure both.

Rear View of Display

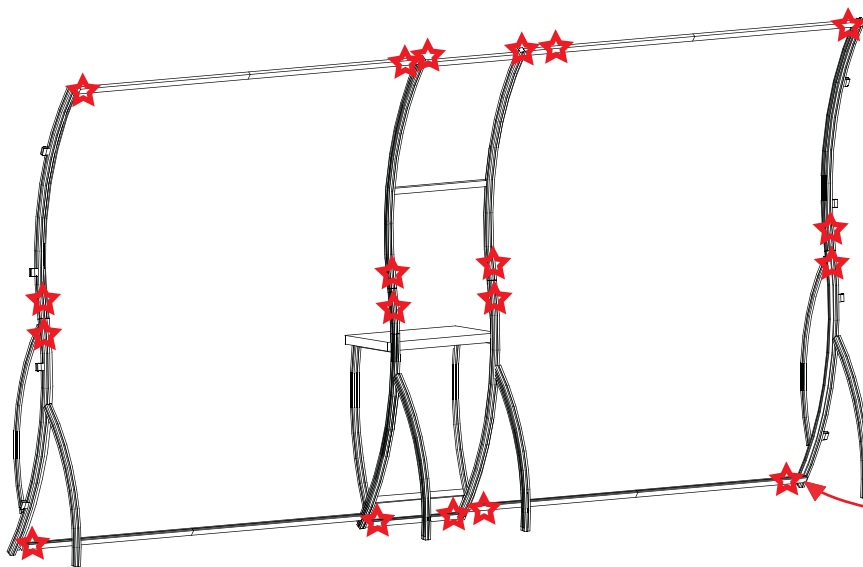

STAR indicates location of knobs on BACKSIDE of unit.

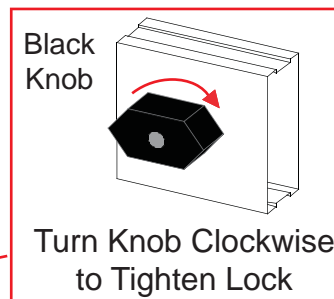

WHEN DISASSEMBLING TIGHTEN ALL KNOBS TO PREVENT LOSS DURING SHIPPING

866.652.2100



*Decorative Blade Attachment (if accidentally removed)*  
Slide A10 Clamp into groove of square extrusion.

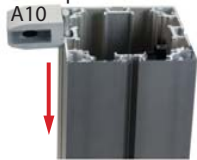

When desired location is found, tighten set screw to secure.

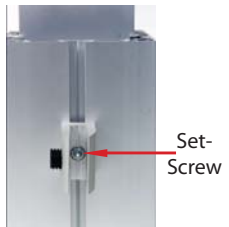

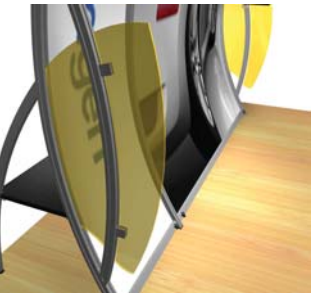

Attach decorative wing and blades to A10's attached to Backwall as shown.



Tighten black plastic set screw to secure Wing in place.



*Hex Key Tool*  
  
(if necessary)

*Flathead Screwdriver*  

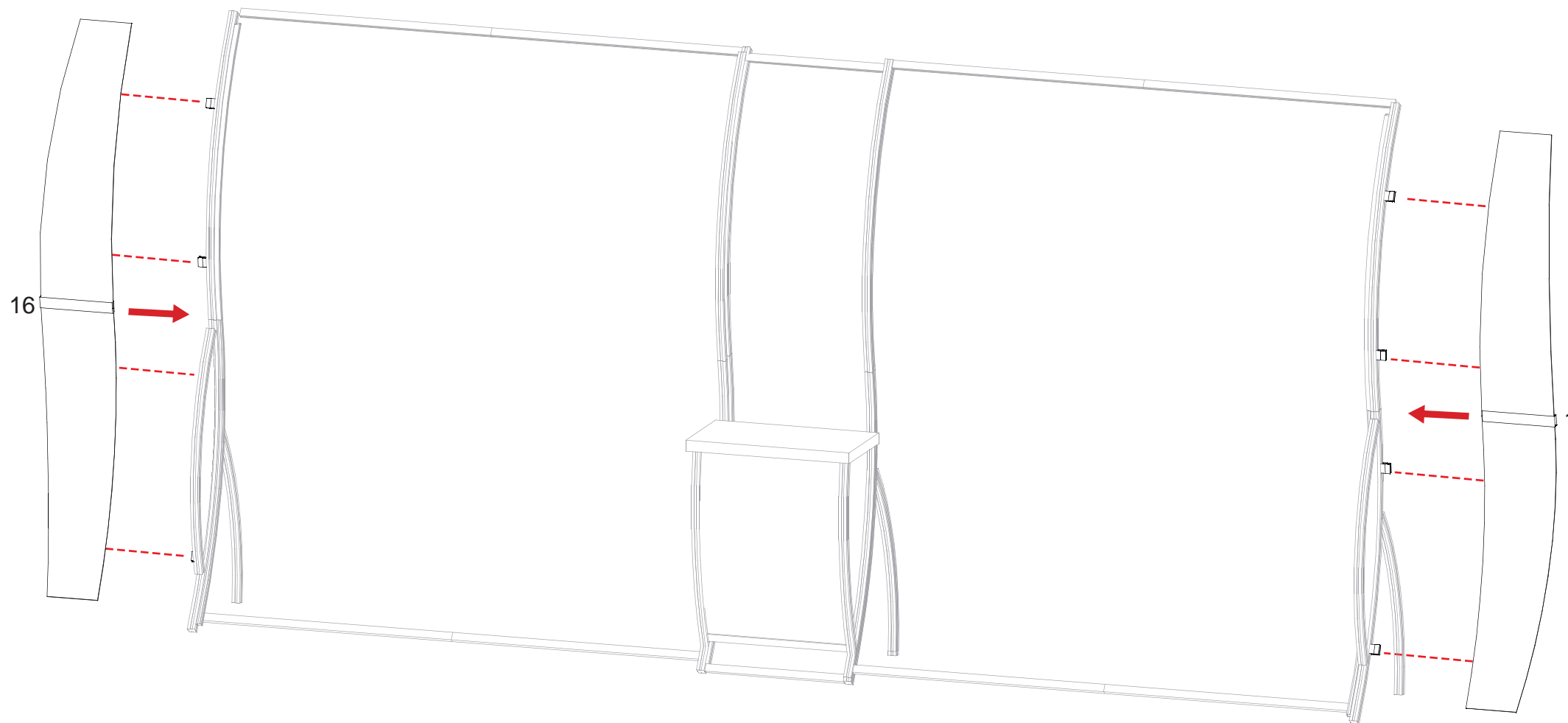

WHEN DISASSEMBLING TIGHTEN ALL KNOBS TO PREVENT LOSS DURING SHIPPING

**\* Monitor Mount Attachment**

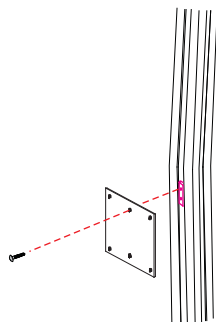

Attach back plate to connectors on vertical extrusion using screws. Then attach top plate and tighten setscrews to secure.

**Header Attachment**

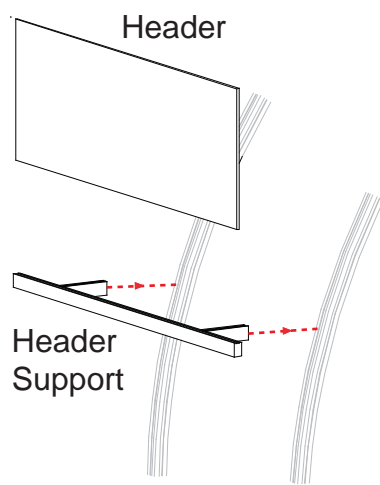

Attach header support then slide header into Groove

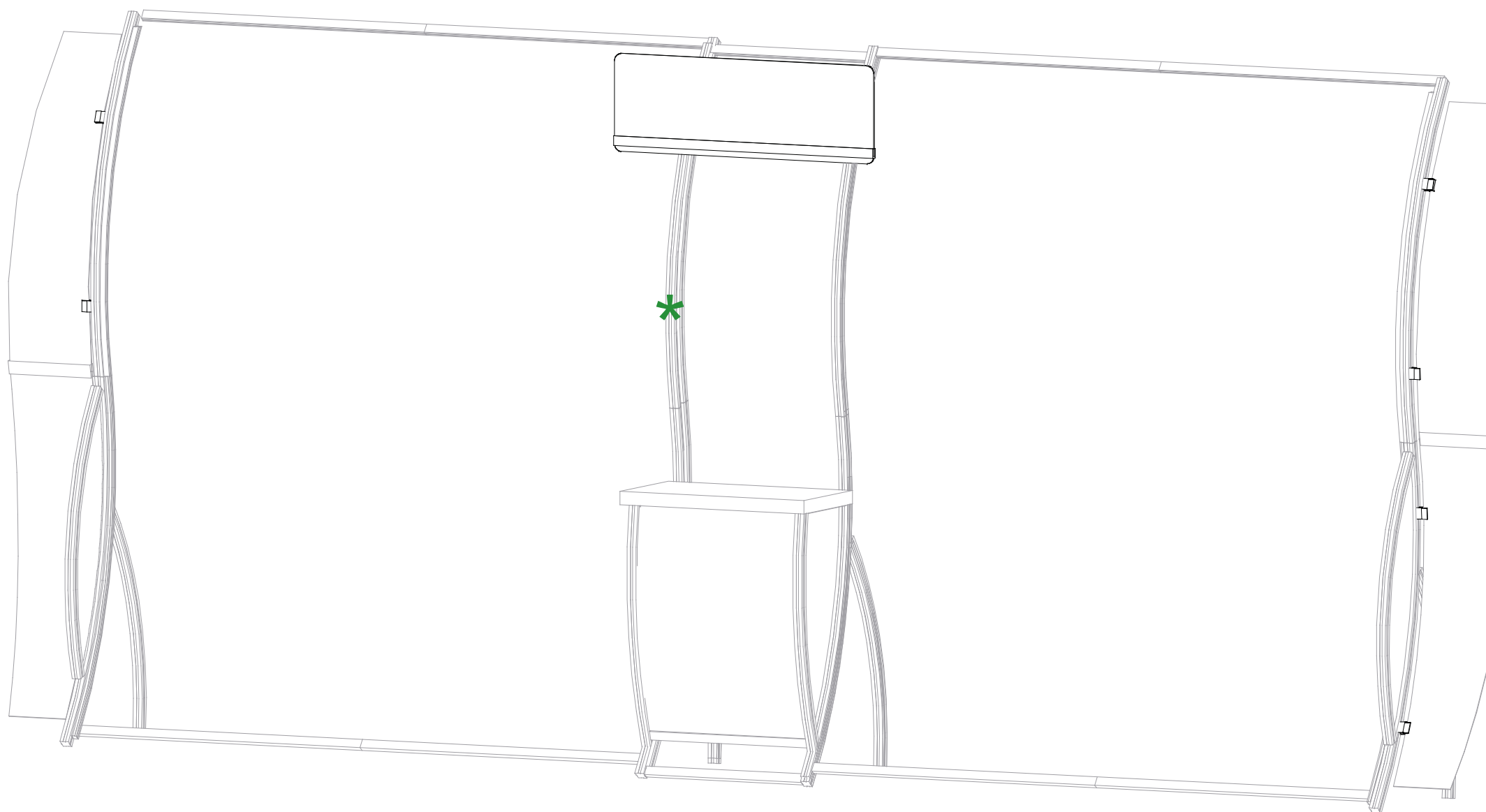

WHEN DISASSEMBLING TIGHTEN ALL KNOBS TO PREVENT LOSS DURING SHIPPING

Part Number	Description
A	Left Leg Assembly
B	Right Leg Assembly
C	Horizontal Extrusion
D	Horizontal Extrusion w/ Door Stopper

Step 1:

- A) Connect lower horizontal extrusion [C] between bottom of leg assemblies [A and B] as shown.
- B) Insert Laminated infill into grooves of leg assemblies [A and B].
- C) Attach extrusion door between leg assemblies [A and B] and atop laminated infill.
- D) Attach upper horizontal extrusion w/ door stopper [D] between leg assemblies [A and B], and set flush with top of legs [A and B].

**NOTE: Make sure the lock is flush with extrusion before tightening. If lock will not fully engage, gently rock lock and extrusion back and forth while turning knob until lock fully opens.**

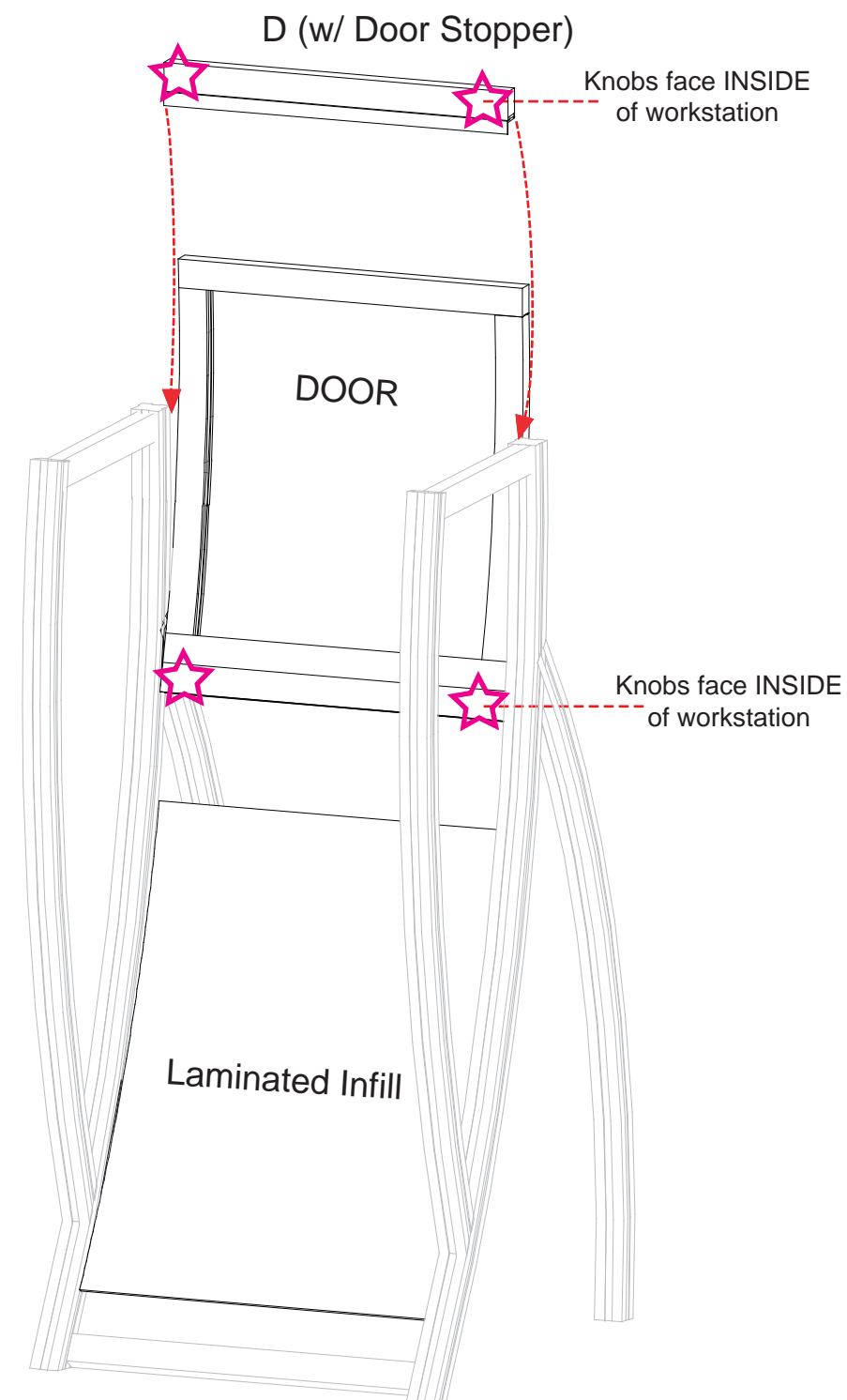
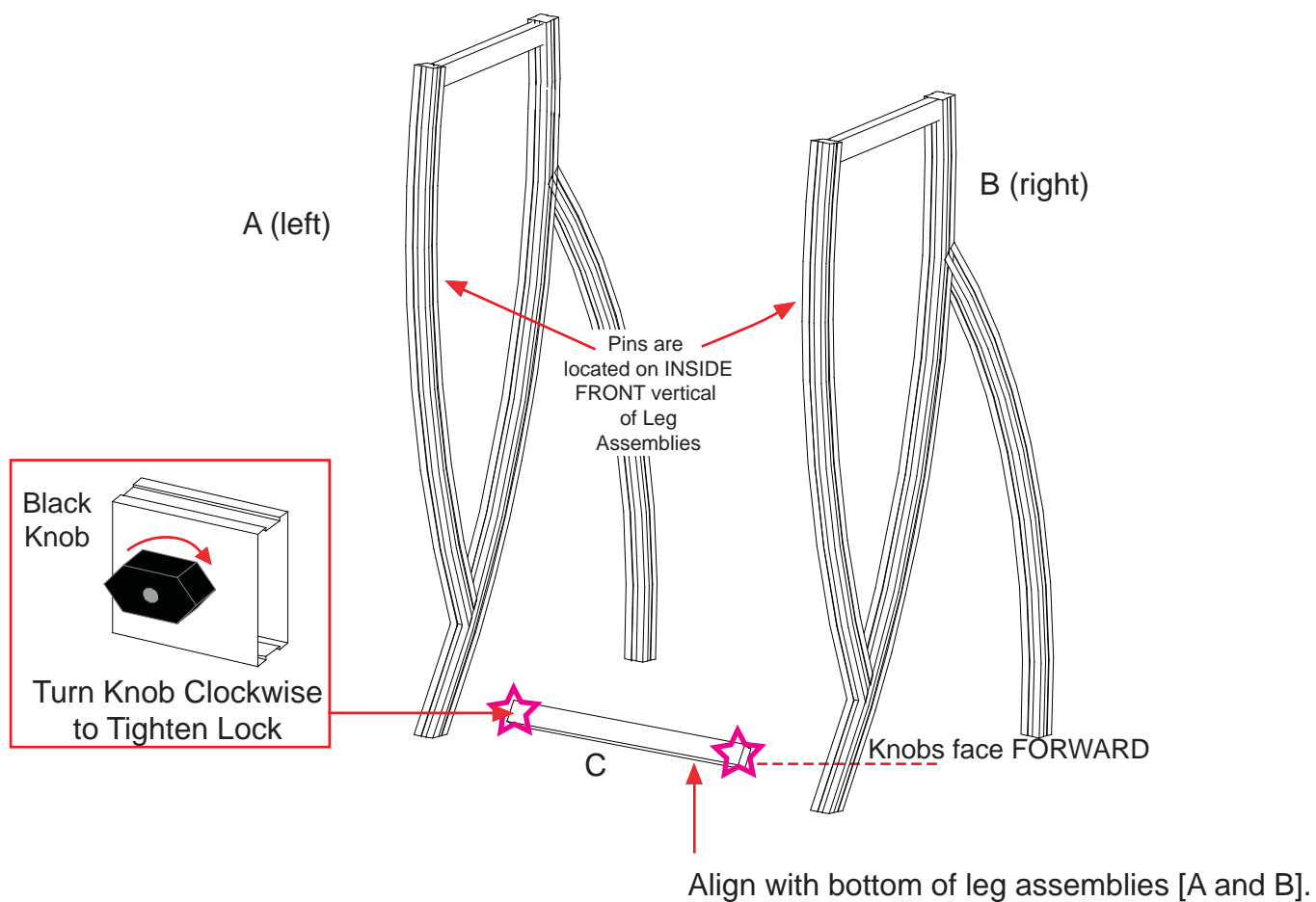

**WHEN DISASSEMBLING TIGHTEN ALL KNOBS TO PREVENT LOSS DURING SHIPPING**

866.652.2100

Part Number	Description
E	Horizontal Extrusion
F	Horizontal Extrusion

Step 2:

- A) Attach horizontal extrusion [E] between vertical leg assemblies [A and B] as shown below.
- B) Insert Laminated infill into grooves of vertical leg assemblies [A and B].
- C) Attach upper horizontal extrusion [F] between vertical leg assemblies [A and B] atop infill.
- D) Place internal shelf into assembled pedestal atop pins..
- E) Set Counter atop assembled pedestal and secure with Velcro straps attached to underside of top.

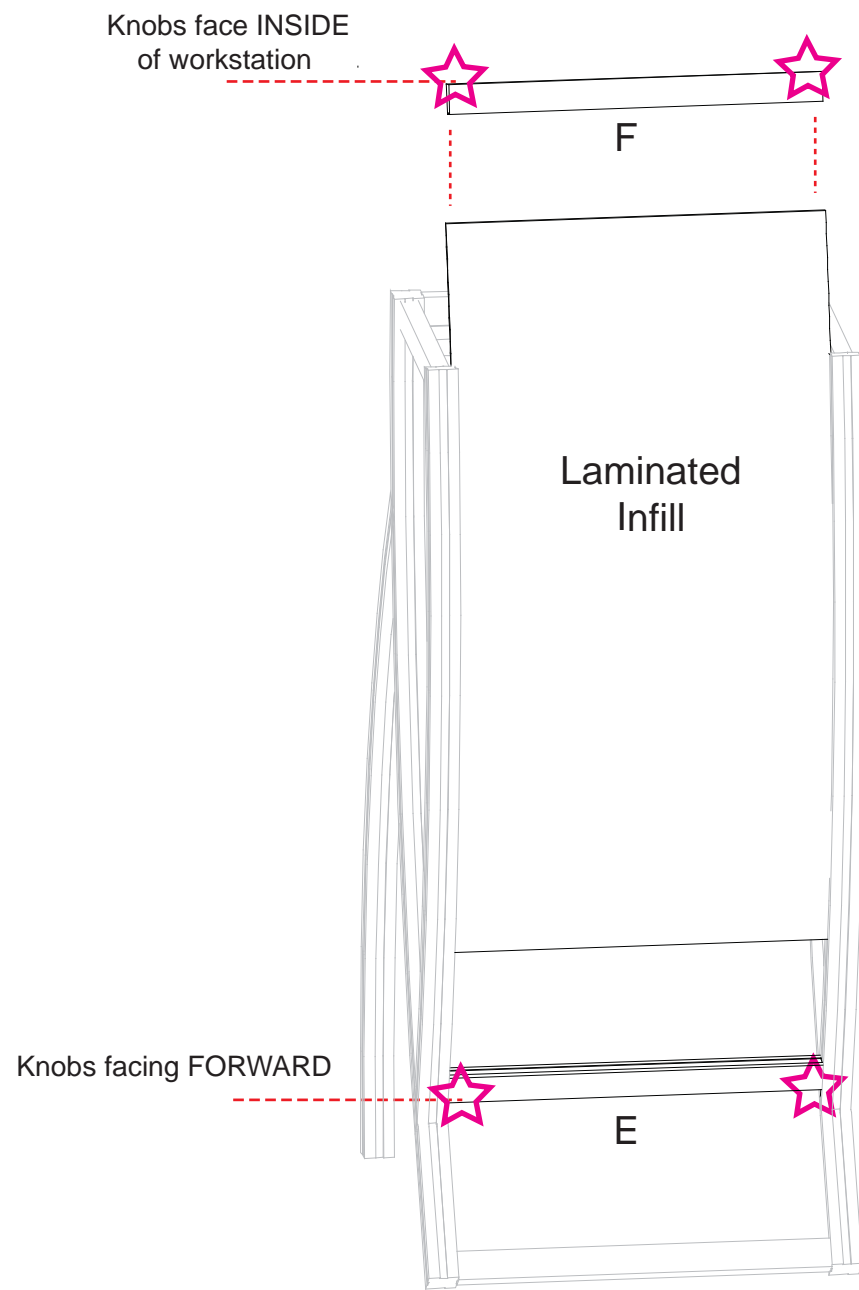

Place internal shelf into workstation then place counter atop assembled workstation.

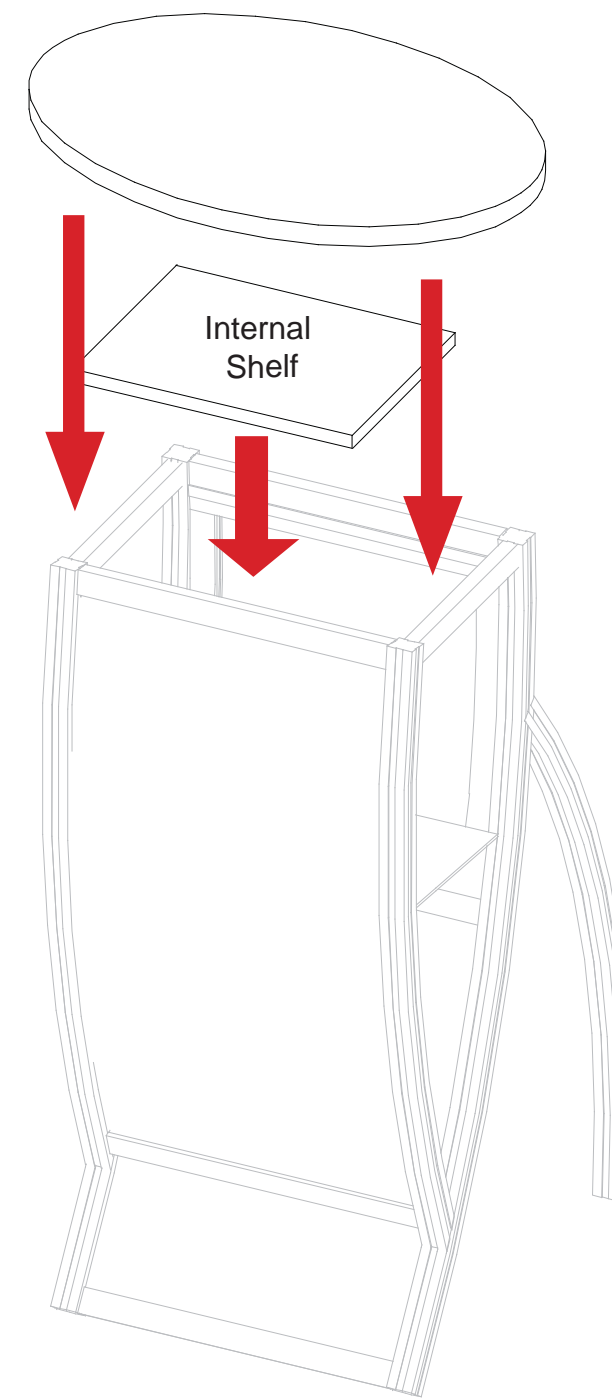

WHEN DISASSEMBLING TIGHTEN ALL KNOBS TO PREVENT LOSS DURING SHIPPING

866.652.2100

Part Number	Description
G	Curved Monitor Mount Extrusion

- Step 3:
- A) Slide Connection Bar into lower leg assembly. Slide upper vertical over bar and secure both.
  - B) Attach Monitor Mount to vertical as shown in Detail below.

*Monitor Mount Attachment*

NOTE: Monitor mount should be installed while laying down on floor

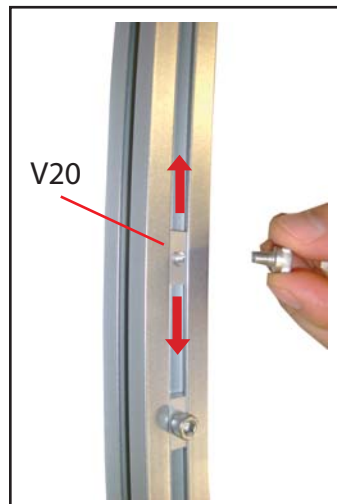

V20

Adjust V20 connector to desired location. Then remove screws.

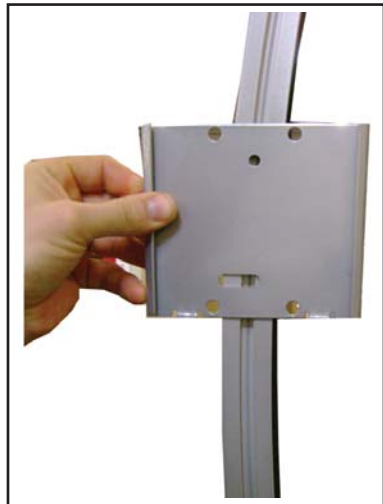

Place mount plate in front of V20 connectors. Then secure with screws.

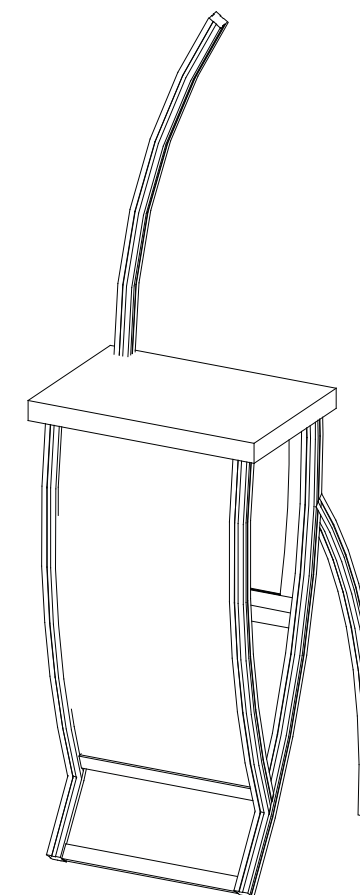
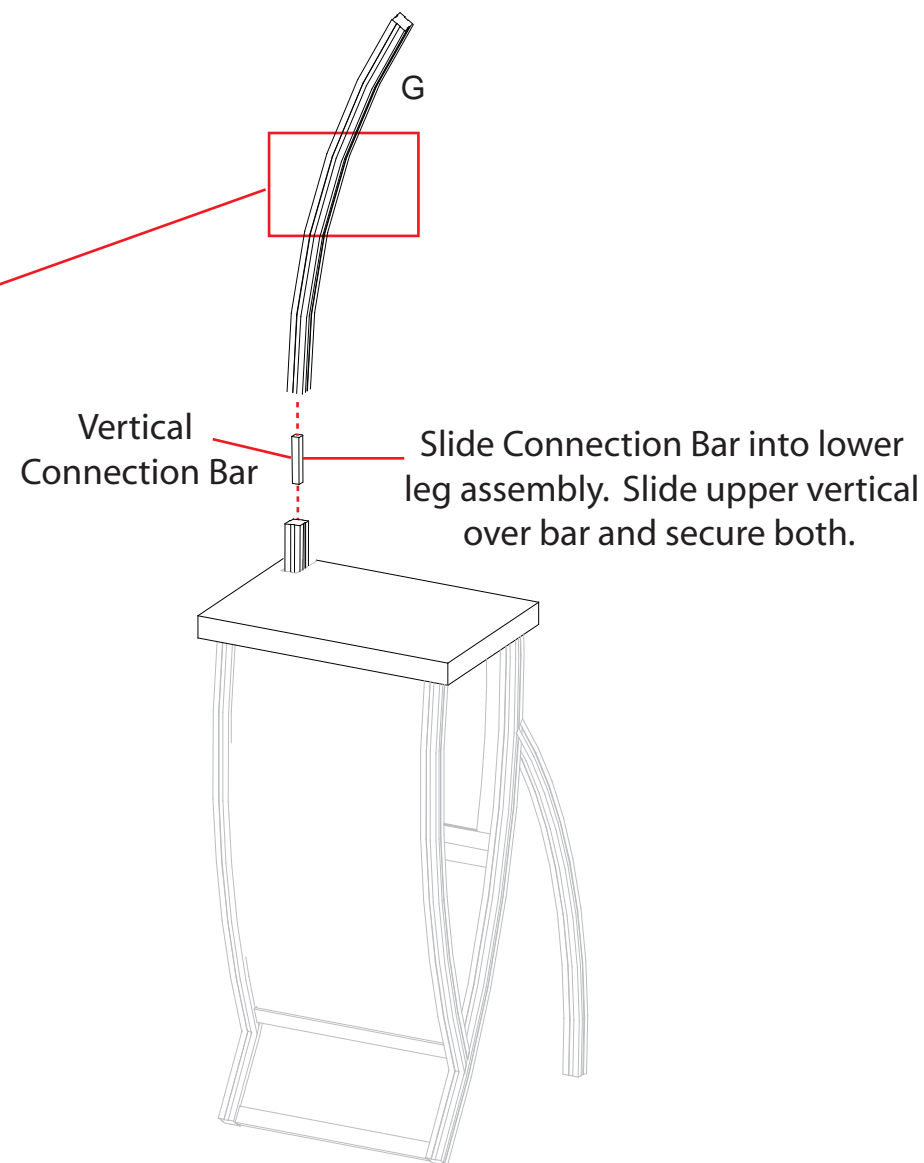
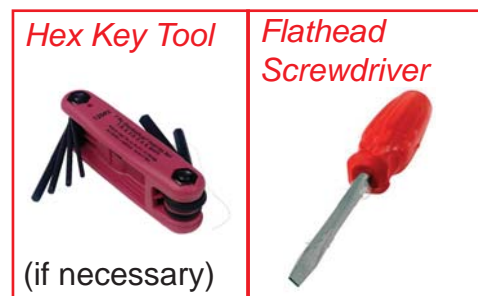

WHEN DISASSEMBLING TIGHTEN ALL KNOBS TO PREVENT LOSS DURING SHIPPING

Case #1 - Backwall Components

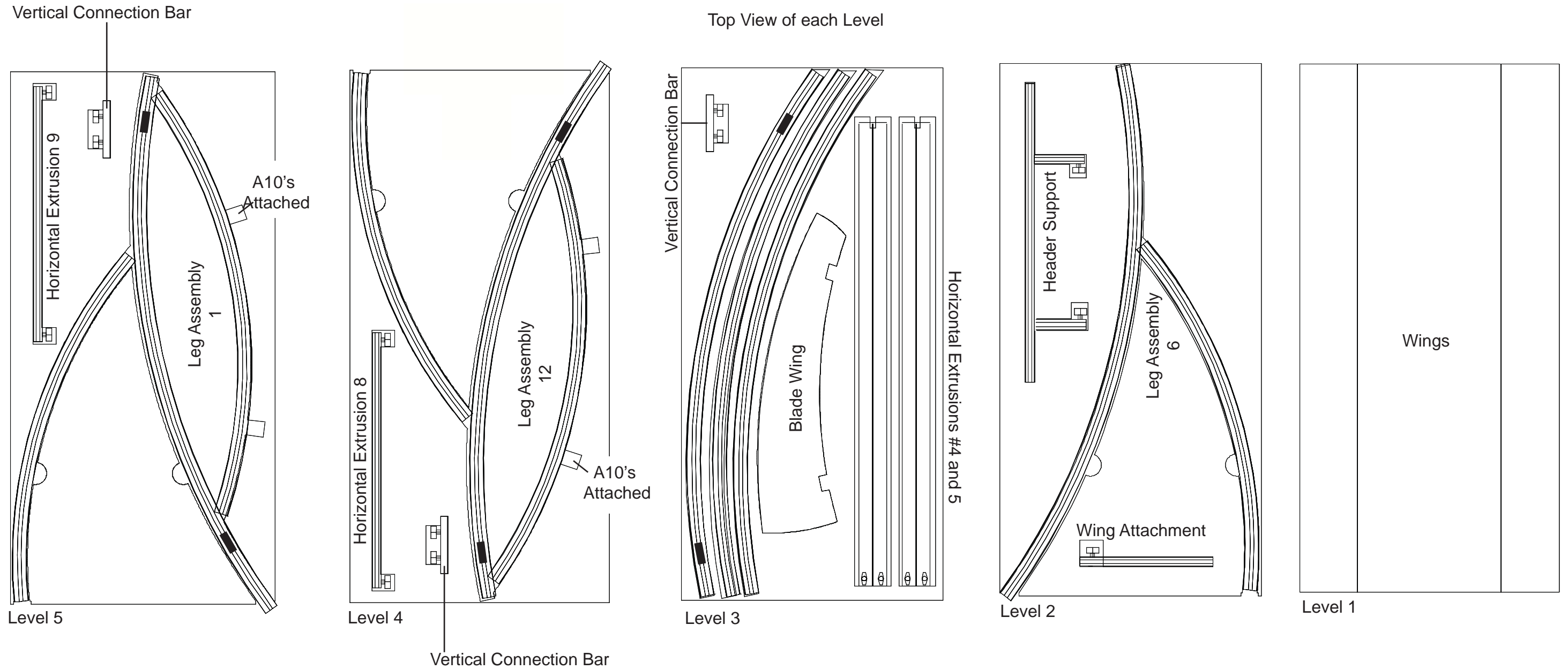

WHEN DISASSEMBLING TIGHTEN ALL KNOBS TO PREVENT LOSS DURING SHIPPING

Case #2 - Backwall Components

Top View of each Level

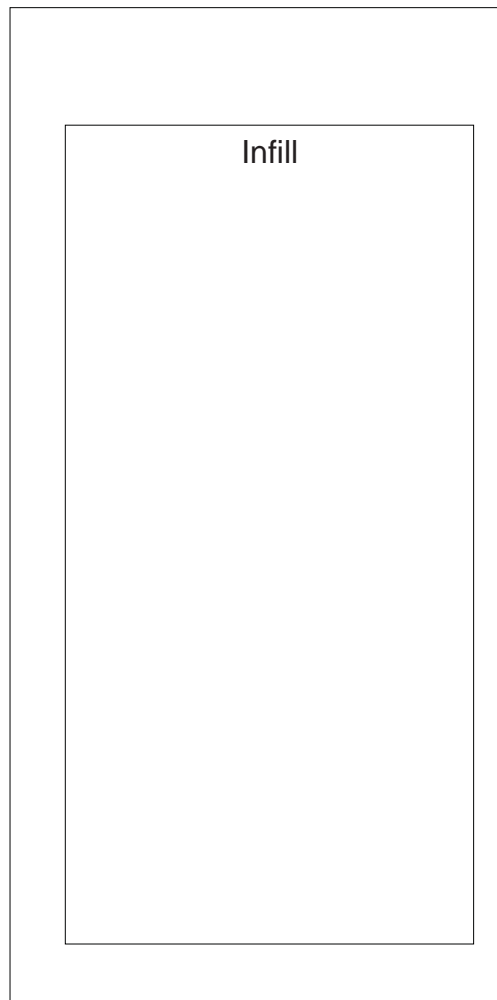

Level 5

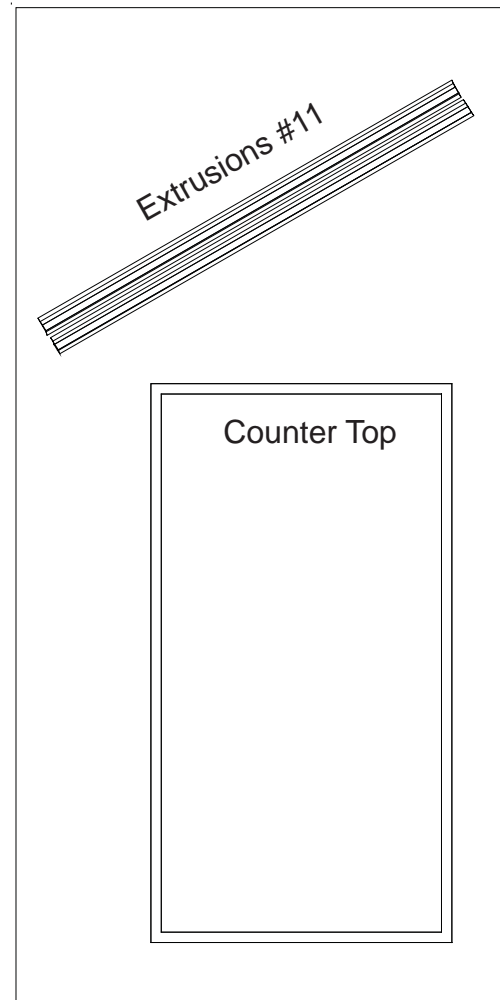

Level 4

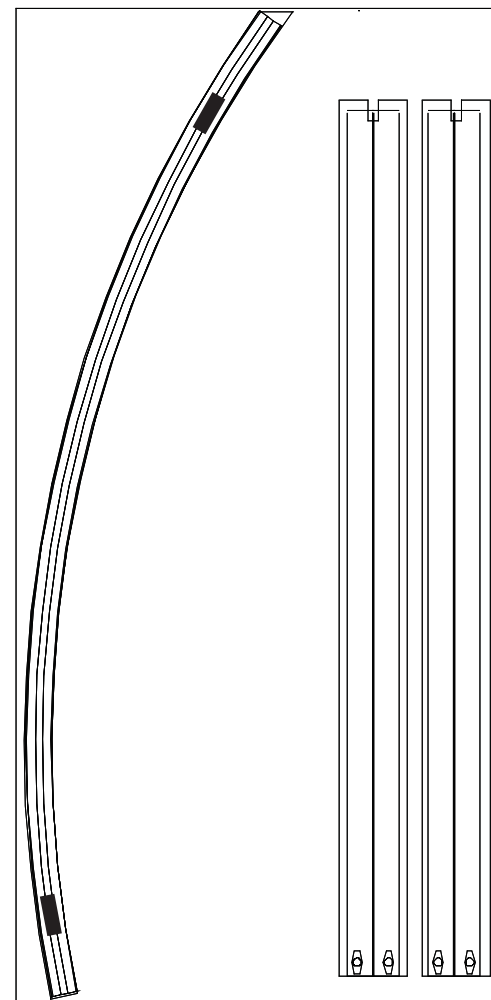

Level 3

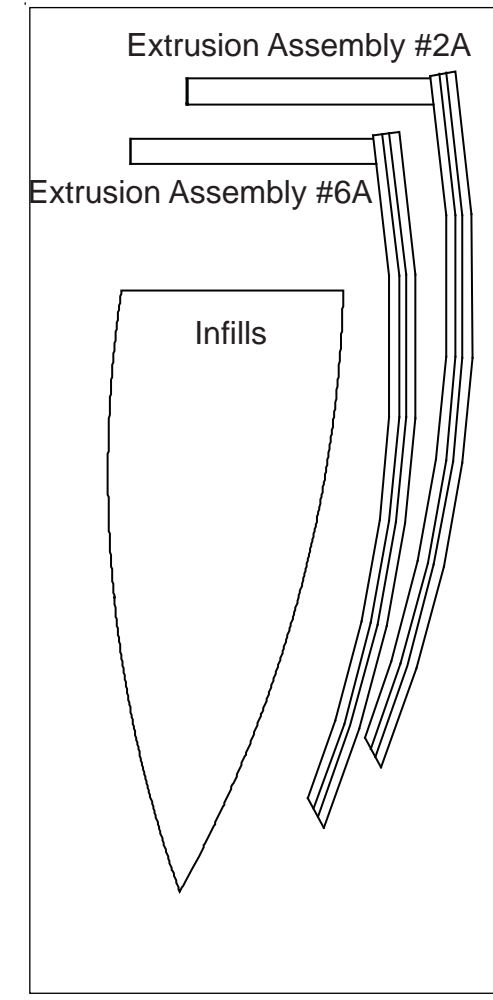

Level 2

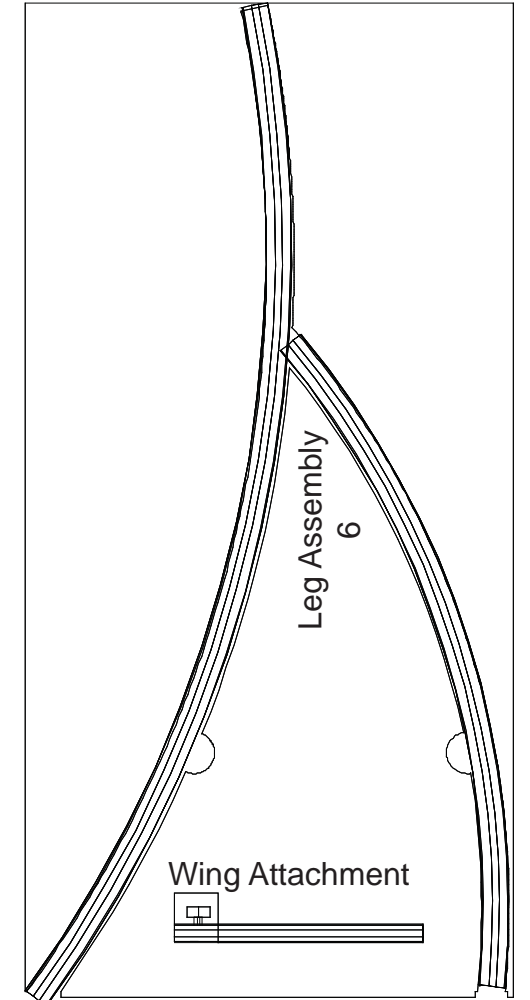

Level 1

- Additional Items:  
- Setup Hardware  
- Halogen Lights

WHEN DISASSEMBLING TIGHTEN ALL KNOBS TO PREVENT LOSS DURING SHIPPING

Case #3 - Workstation Components

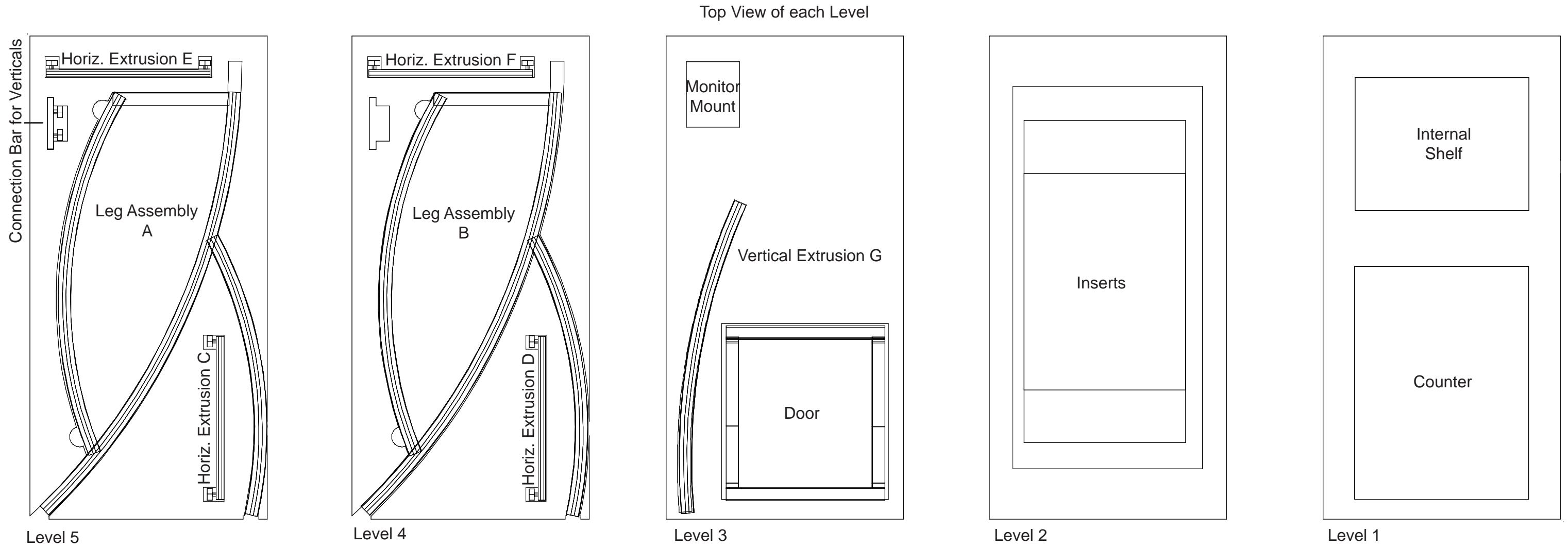

WHEN DISASSEMBLING TIGHTEN ALL KNOBS TO PREVENT LOSS DURING SHIPPING

Case #4 - Workstation Components

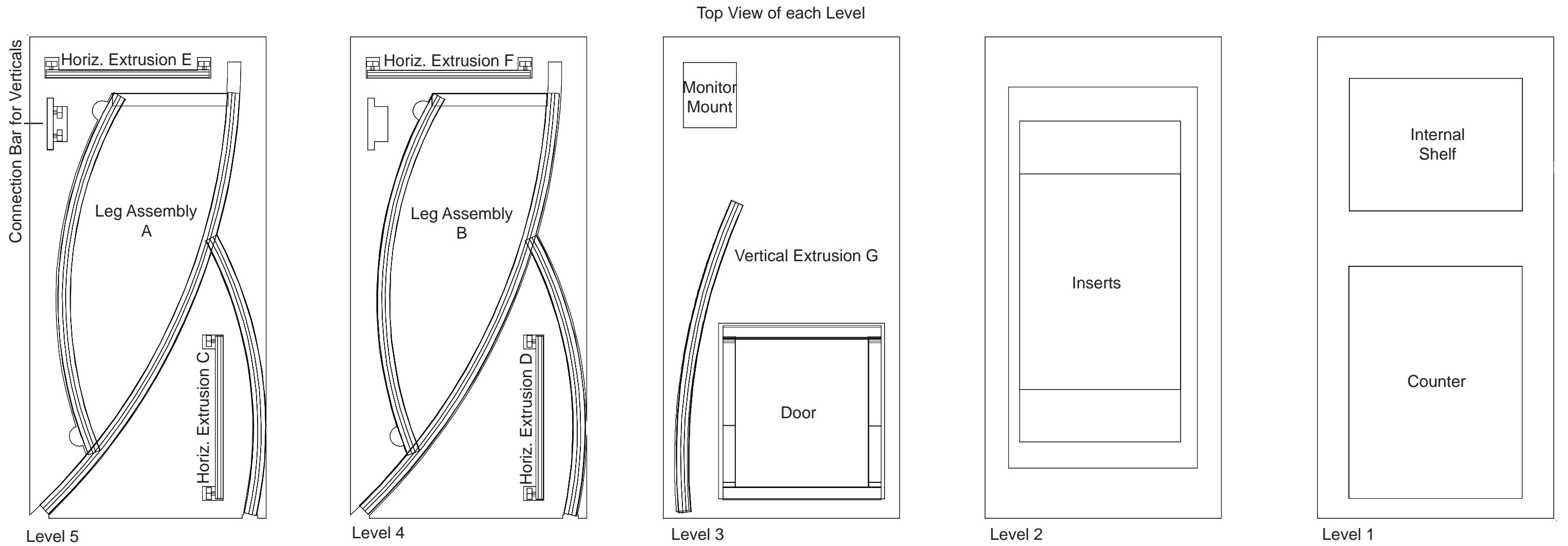

WHEN DISASSEMBLING TIGHTEN ALL KNOBS TO PREVENT LOSS DURING SHIPPING