

Perfect 10 Hybrid Displays

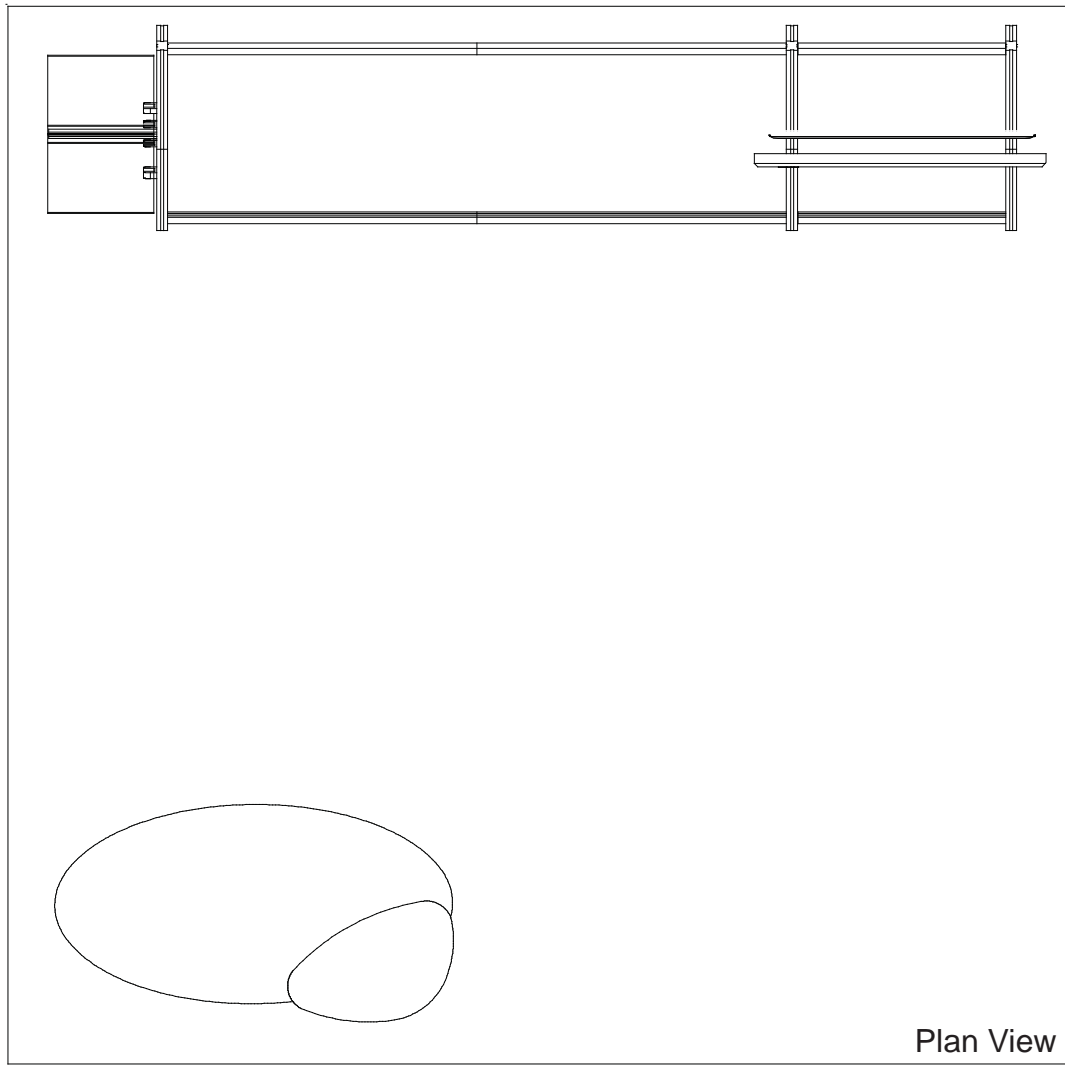

10'

10'

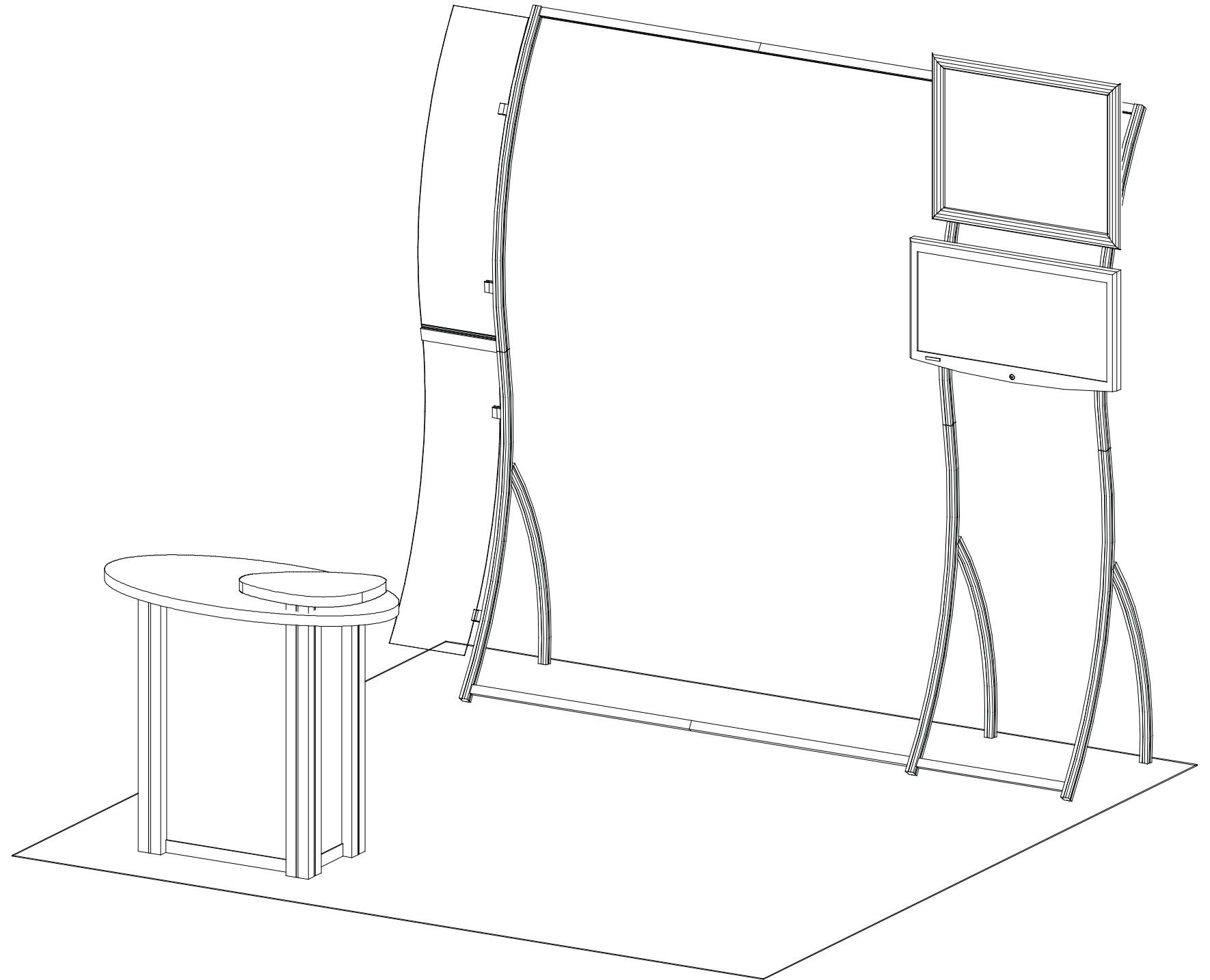

WHEN DISASSEMBLING TIGHTEN ALL KNOBS TO PREVENT LOSS DURING SHIPPING

866.652.2100

Part Number	Description
1	Left Leg Assembly w/ Clamps Attached
2	Middle Leg Assembly
3A	Upper Curved Vertical Clamps Attached
3	Upper Curved Vertical
4	69" w Horizontal

NOTE: When assembling horizontals they should be placed approximately one inch from TOP and BOTTOM.

Step 1

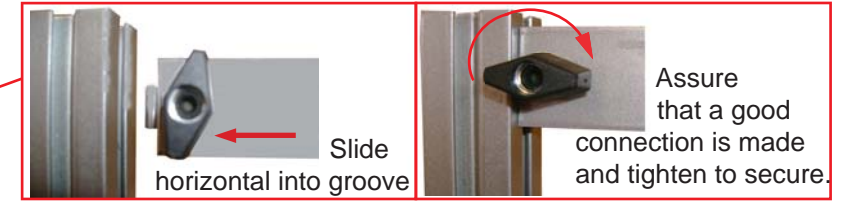

Steps:

NOTE: Can be assembled either face down on floor then lifted upright or upright as shown in drawings.



- A) Connect vertical leg assemblies [1 and 2] together by connecting horizontal extrusions [4] between assemblies tightening BLACK knobs on backside of extrusion making sure Velcro faces toward BACK and placing it about one inch up from bottom and tightening.
- B) Connect vertical extrusions [3 and 3A] to leg assemblies [1 and 2] using vertical connection bar as shown.
- C) Connect upper horizontal extrusion [5] between verticals [3 and 3A] setting bar atop stopper, then attach lower horizontal extrusion [4].

NOTE: Make sure the lock is flush with extrusion before tightening. If lock will not fully engage, gently rock lock and extrusion while turning knob until lock fully opens.

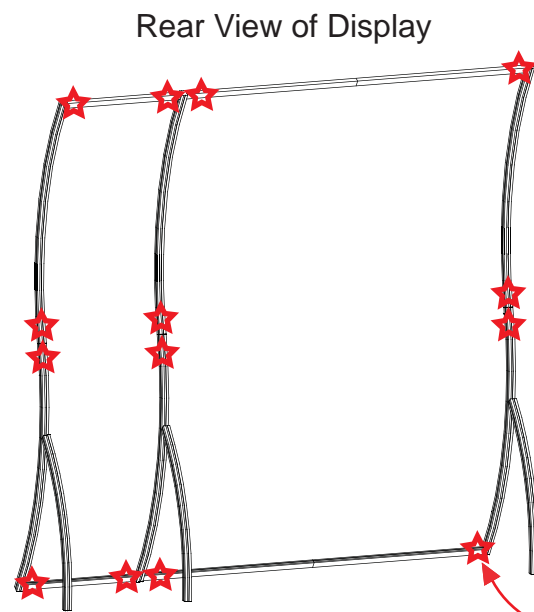
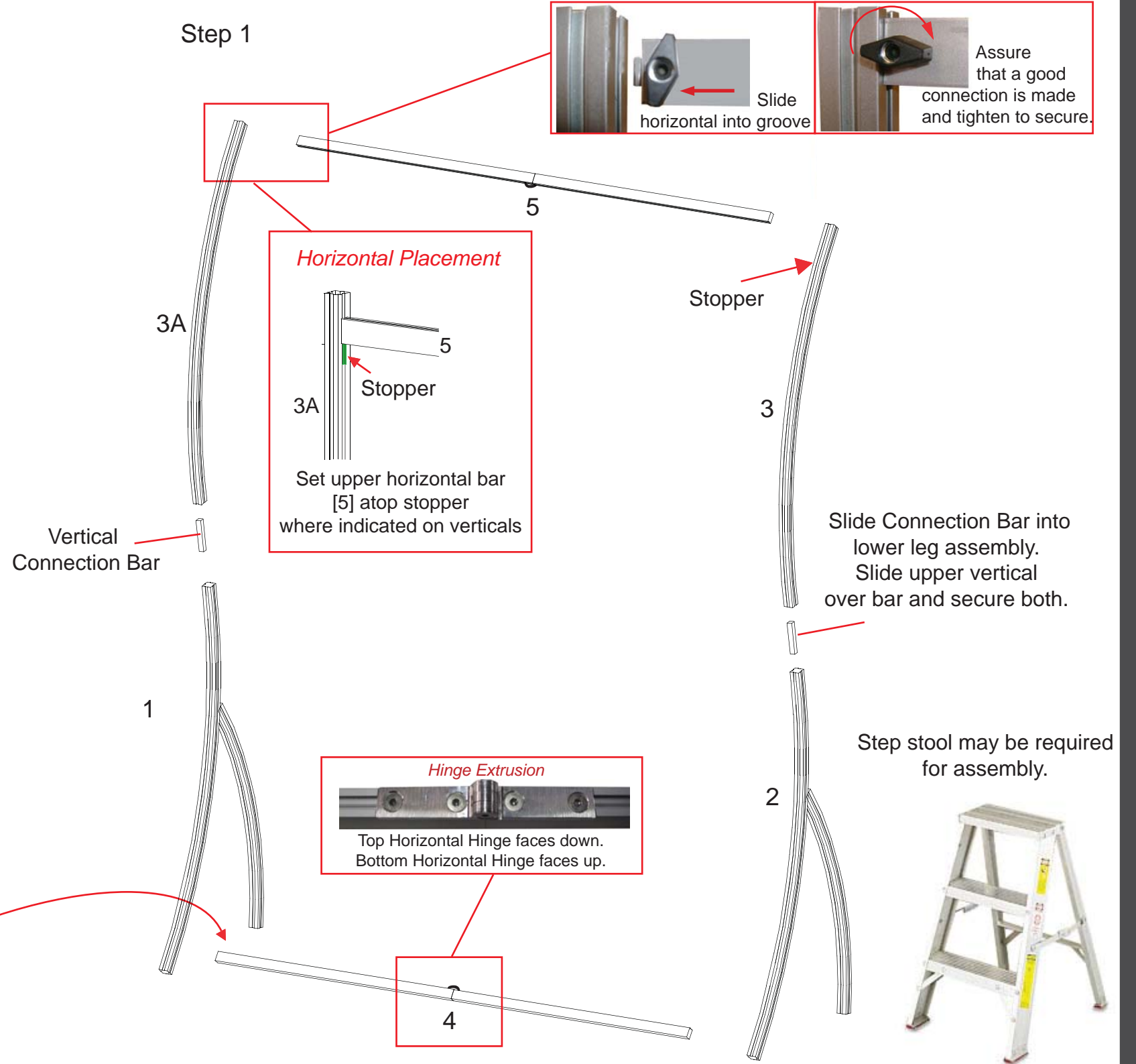

STAR indicates location of knobs on BACKSIDE of unit.

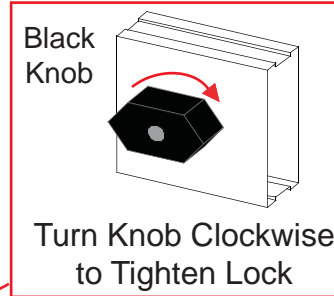

WHEN DISASSEMBLING TIGHTEN ALL KNOBS TO PREVENT LOSS DURING SHIPPING

866.652.2100

Part Number	Description
6	Right Leg Assembly
7	Upper Curved Vertical
8	23" w Horizontal
9	20" w Horizontal Extrusion for Monitor Mount Attachment

NOTE: When assembling horizontals they should be placed approximately one inch from TOP and BOTTOM.

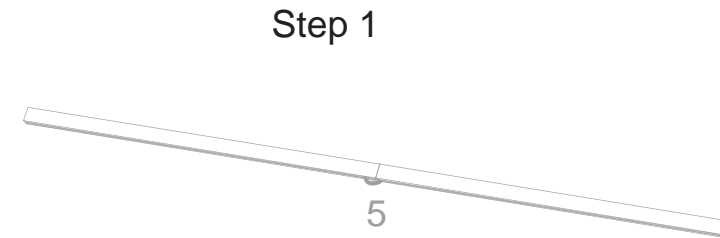
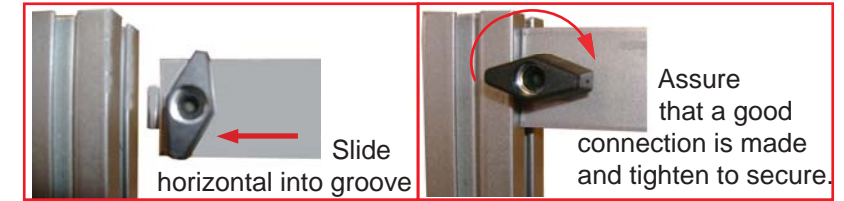

Step 1



Steps:
NOTE: Can be assembled either face down on floor then lifted upright or upright as shown in drawings.

- A) Connect vertical leg assemblies [2 and 6] together by connecting horizontal extrusions [8] between assemblies tightening BLACK knobs on backside of extrusion making sure Velcro faces toward BACK and placing it about one inch up from bottom and tightening.
- B) Connect vertical extrusion [7] to leg assembly [6] using vertical connection bar as shown.
- C) Connect upper horizontal extrusion [8 and 9] between verticals [3 and 7] setting bar atop stopper.

NOTE: Make sure the lock is flush with extrusion before tightening. If lock will not fully engage, gently rock lock and extrusion while turning knob until lock fully opens.

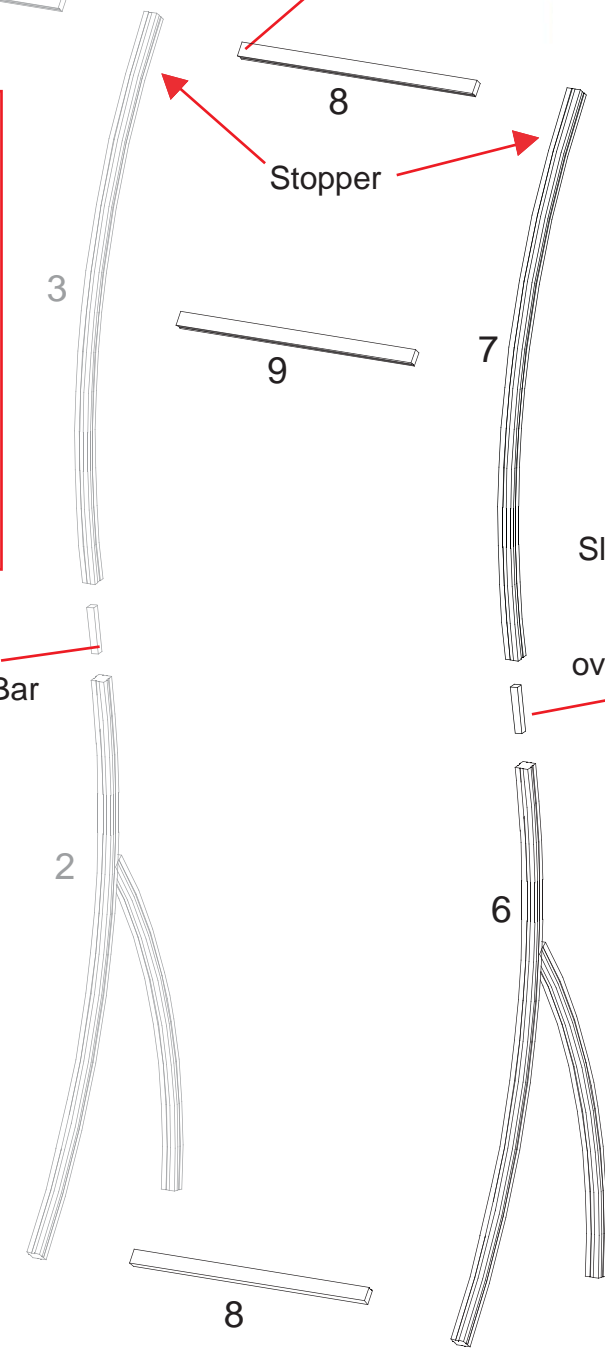
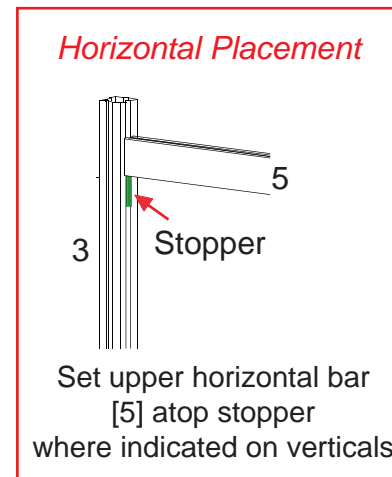

Slide Connection Bar into lower leg assembly. Slide upper vertical over bar and secure both.

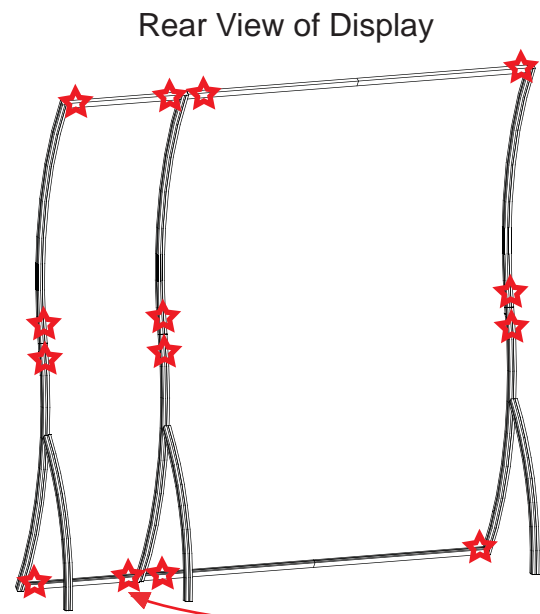

STAR indicates location of knobs on BACKSIDE of unit.

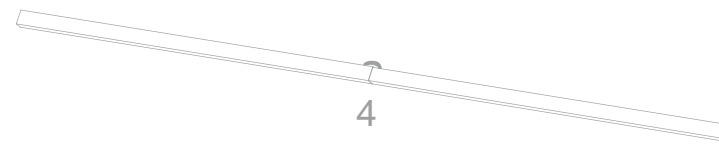
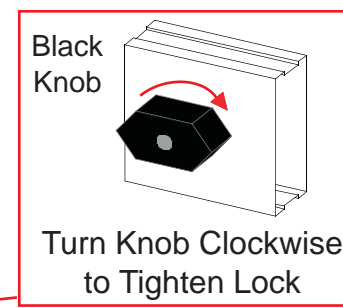

WHEN DISASSEMBLING TIGHTEN ALL KNOBS TO PREVENT LOSS DURING SHIPPING

866.652.2100

Decorative Wing Attachment
(if accidentally removed)

Slide A10 Clamp into groove of square extrusion.

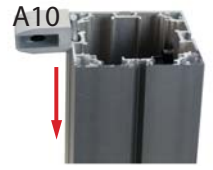

When desired location is found, tighten set screw to secure.

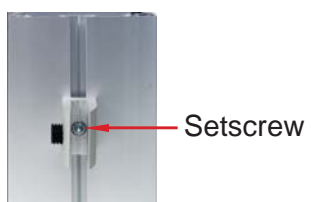

Tighten black plastic set screw to secure Wing in place.

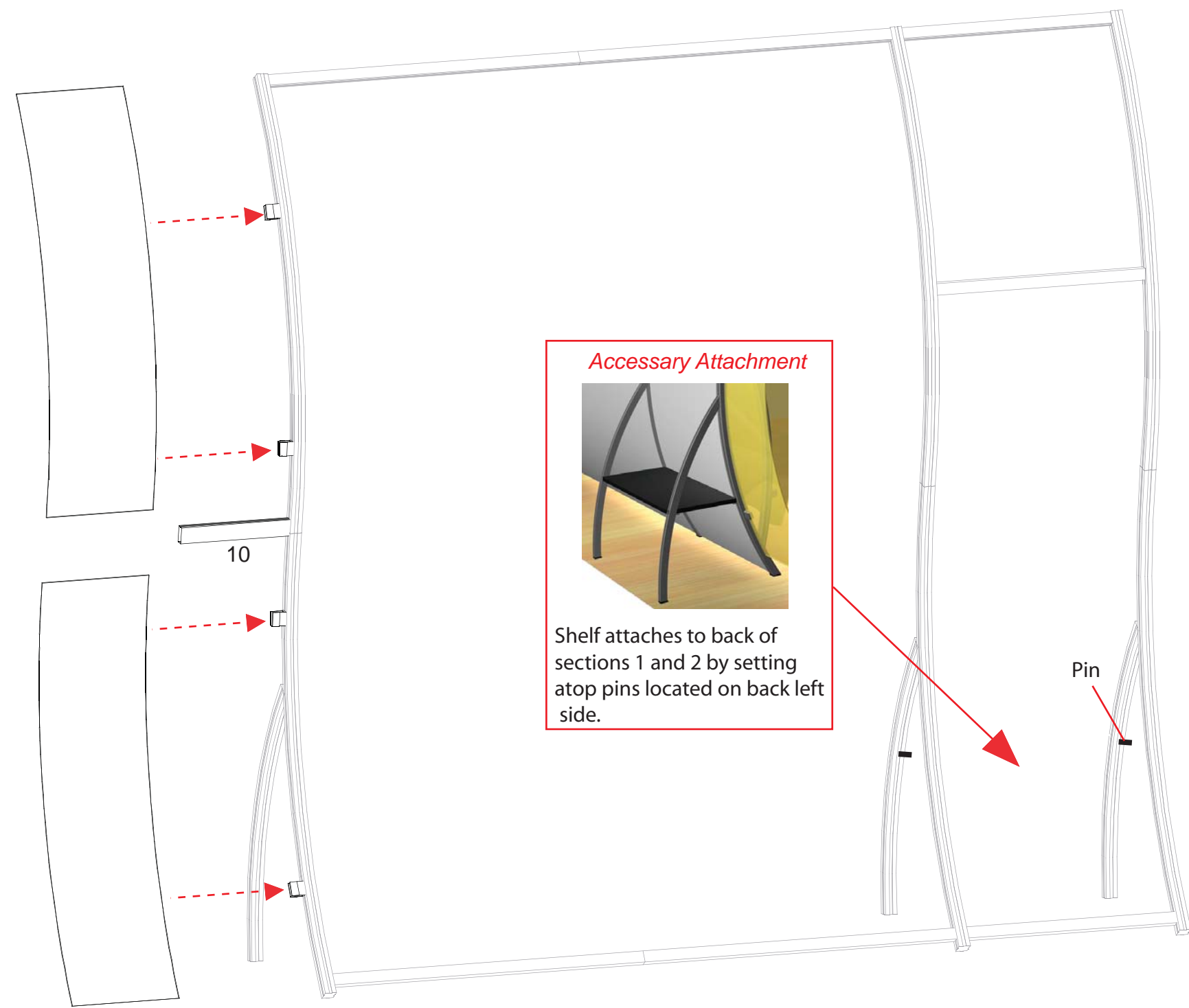
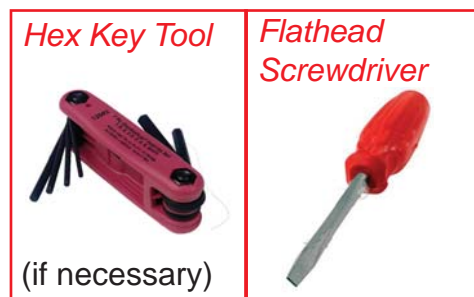
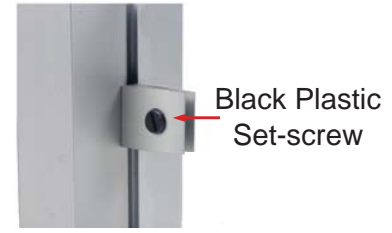

Accessory Attachment



Shelf attaches to back of sections 1 and 2 by setting atop pins located on back left side.

Header Attachment
*****OPTIONAL****

Attach Header support then Slide header into Groove

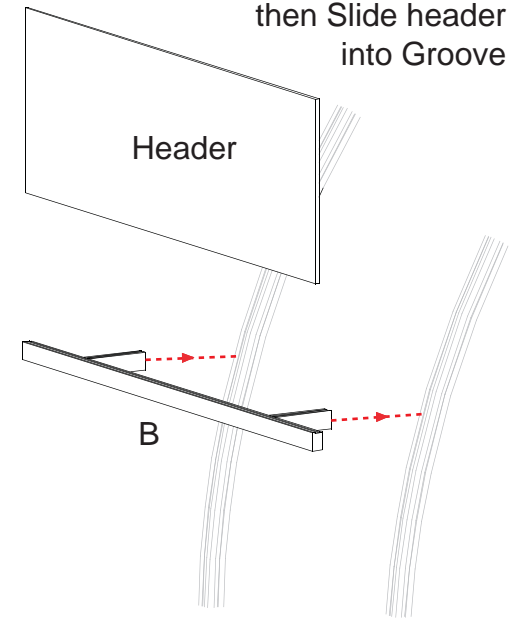

WHEN DISASSEMBLING TIGHTEN ALL KNOBS TO PREVENT LOSS DURING SHIPPING

Steps:

- A) Attach light box support bars [A and B] to assembled backwall as shown.
- B) Hook light box to support bars.

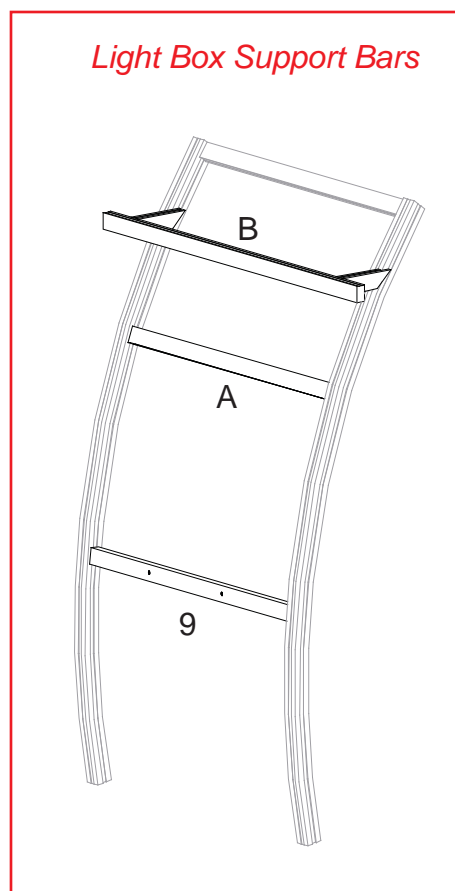
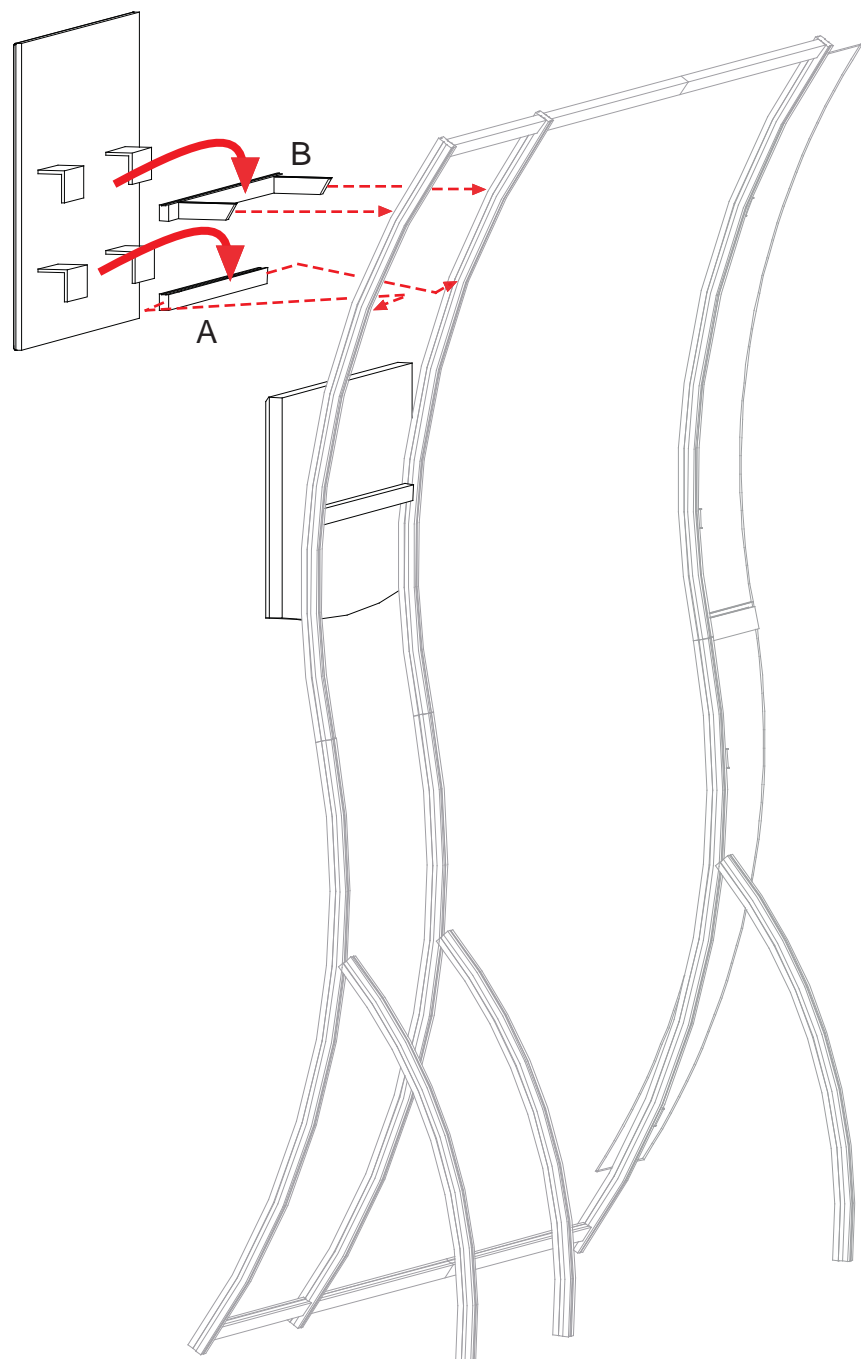

Steps:

- A) Attach wall mount to horizontal [9] and secure with wing nuts.

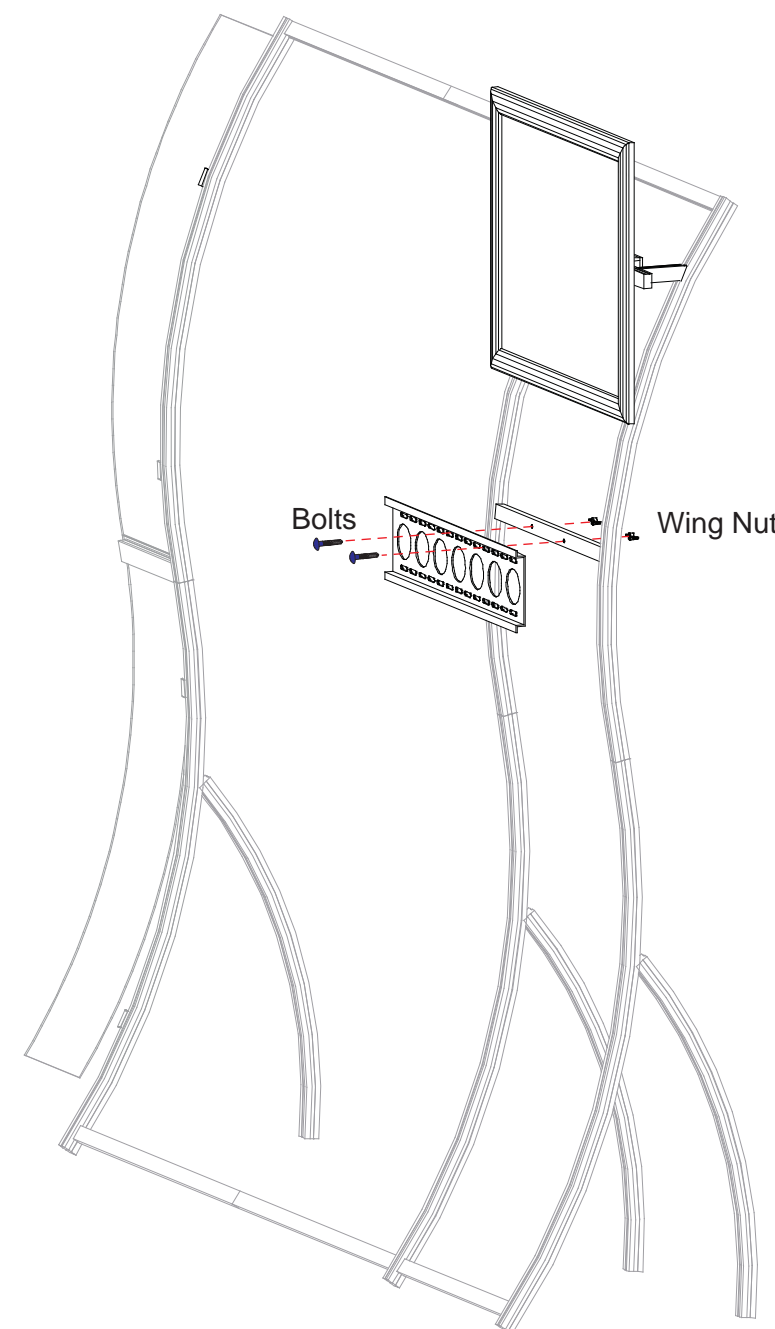

WHEN DISASSEMBLING TIGHTEN ALL KNOBS TO PREVENT LOSS DURING SHIPPING

866.652.2100

Item	Quantity	Description
11	1	38"h Vertical Extrusion
12	1	38"h Vertical Extrusion
13	1	38"h Vertical Extrusion
14	1	42"h Vertical Extrusion
14a	1	Plate for Counter Connection
15	2	20"w Horizontal Extrusion
16	2	8.5"w Horizontal Extrusion
17	2	20"w Horizontal Extrusion
18	2	8.5"w Horizontal Extrusion
	4	Internal Shelf Support

Steps:

- 1) Connect horizontal extrusions [15 and 16] between vertical extrusions [11, 12, 13 and 14] resting atop stoppers at approximately 4" up from floor to bottom of metal.
- 2) Set floor in place atop lip of horizontal extrusions.
- 3) Place doors and inserts in place as shown.
- 4) Connect horizontal extrusions [17 and 18] between vertical extrusions [11, 12, 13 and 14] and atop inserts and door.
- 5) Velcro shelf supports to inside of pedestal, then set internal shelf atop supports.
- 6) Place counter atop assembled pedestal, attach [14a] to extrusion [3] then connect smaller counter to [14a].

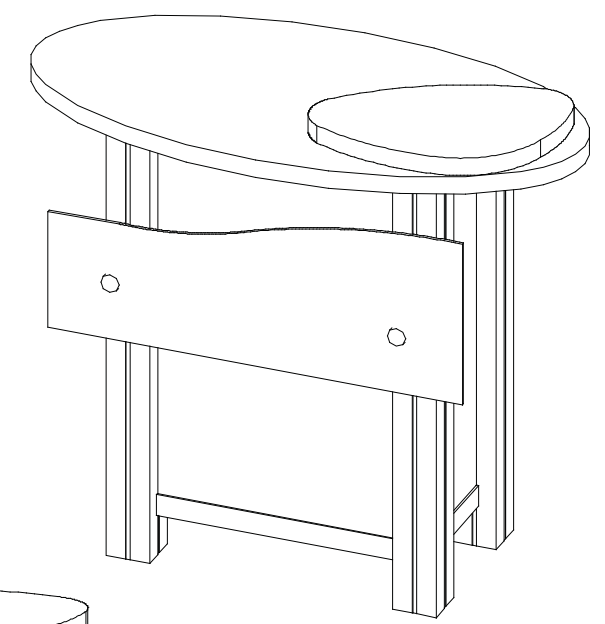

NOTE: TOP SIDE Label needs to be at top of round extrusion.

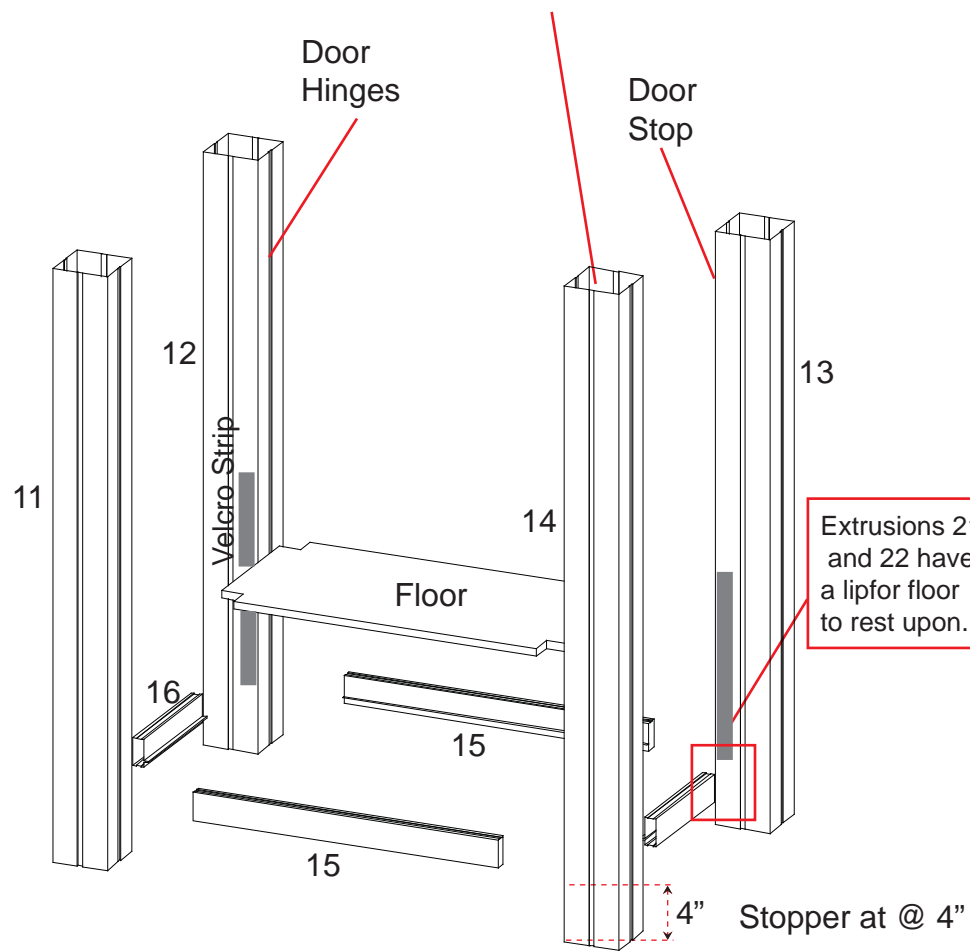

Extrusions 21a and 22 have a lip for floor to rest upon.

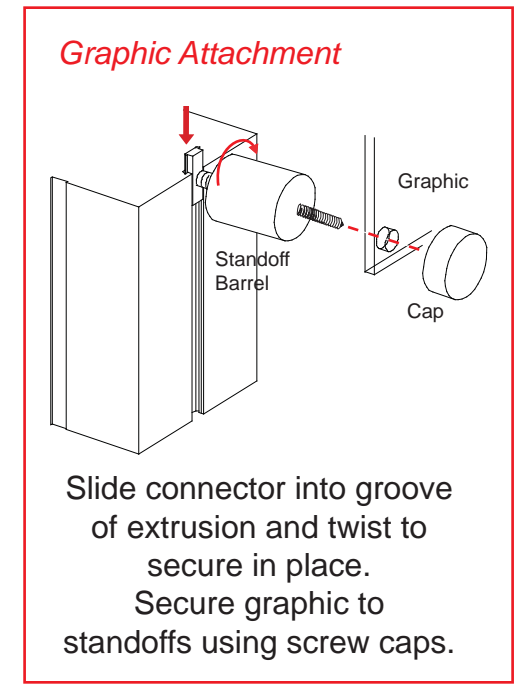
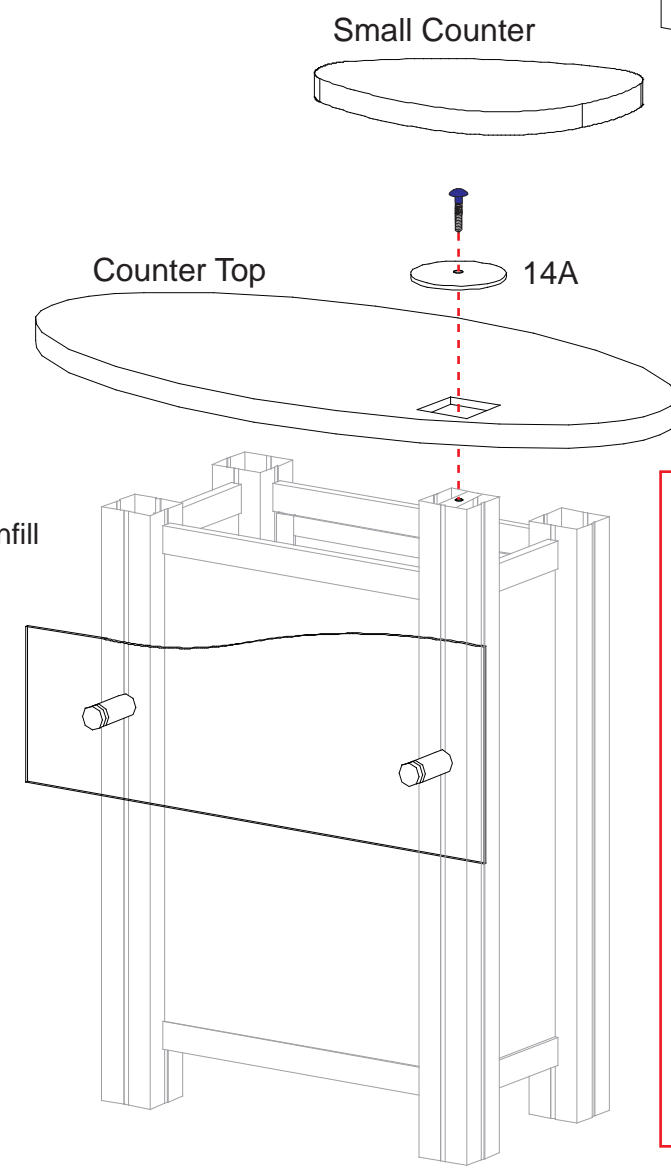
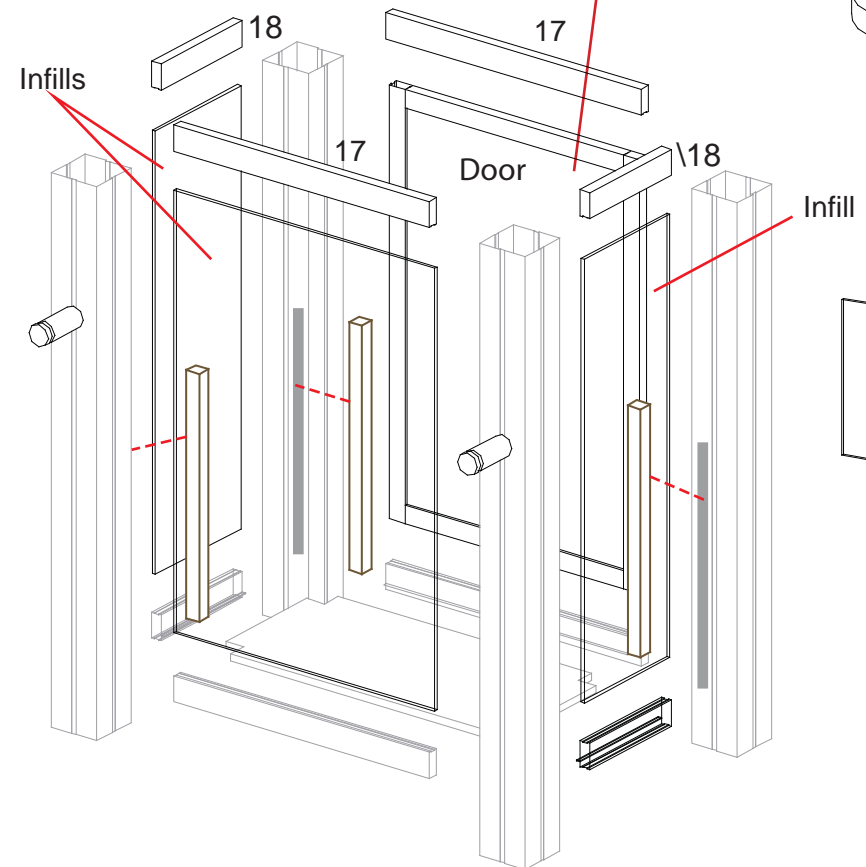
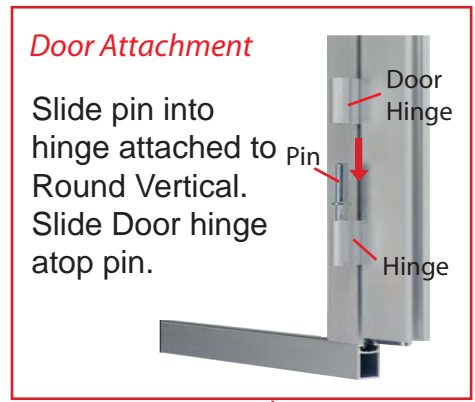

Slide connector into groove of extrusion and twist to secure in place. Secure graphic to standoffs using screw caps.

WHEN DISASSEMBLING TIGHTEN ALL KNOBS TO PREVENT LOSS DURING SHIPPING

Case #1 - Backwall Components

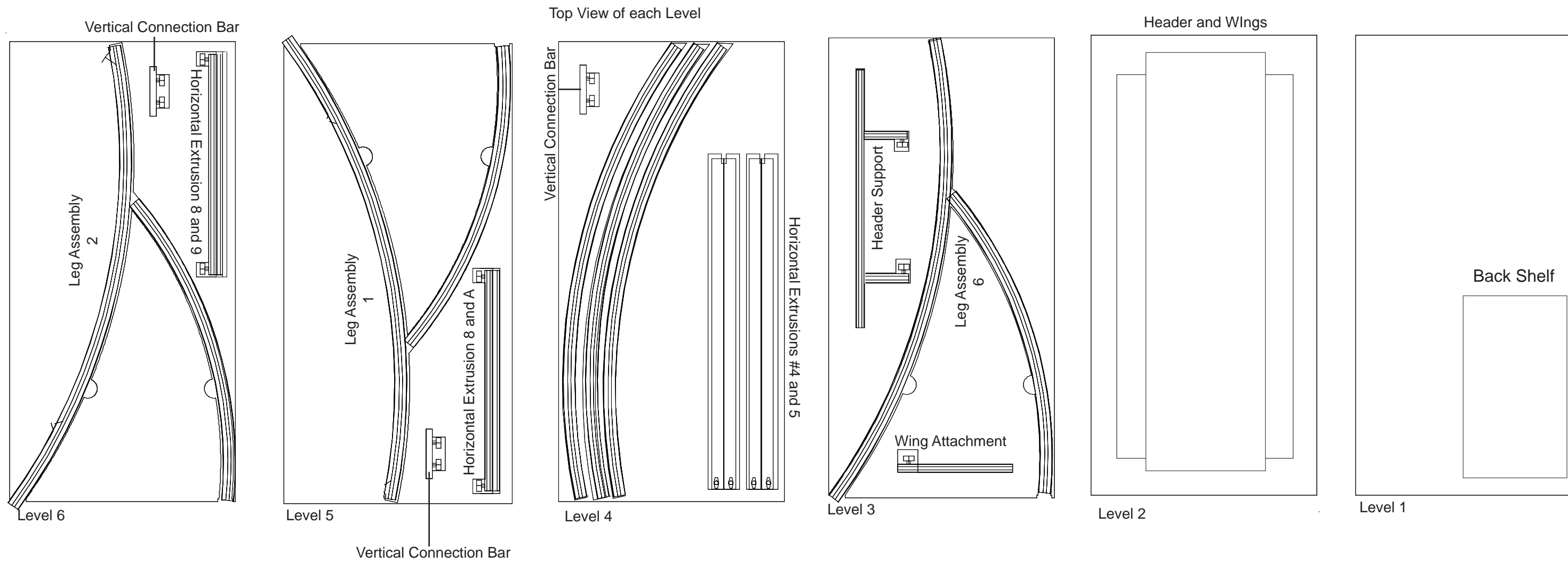

WHEN DISASSEMBLING TIGHTEN ALL KNOBS TO PREVENT LOSS DURING SHIPPING

Case #2 - Pedestal Components

Top View of Each Level

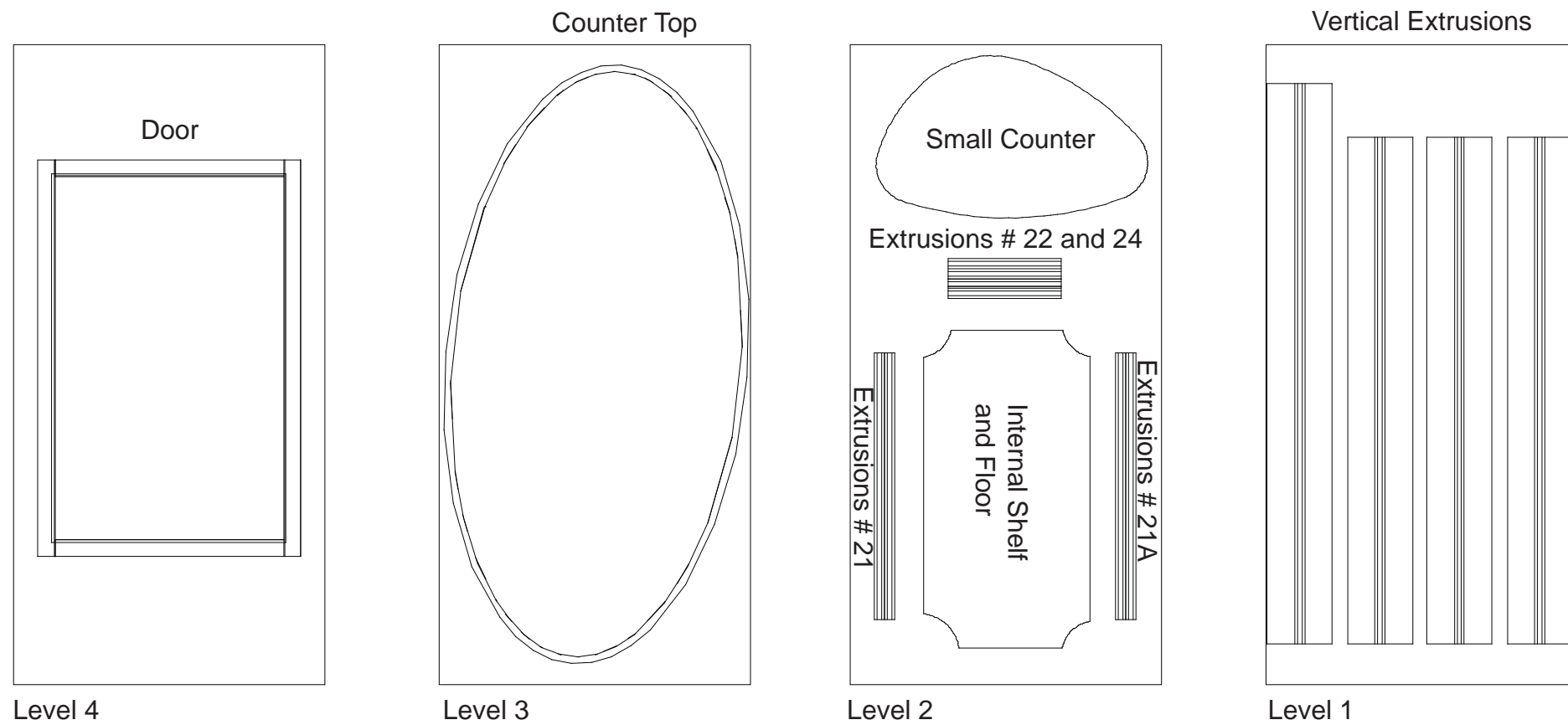

WHEN DISASSEMBLING TIGHTEN ALL KNOBS TO PREVENT LOSS DURING SHIPPING

Top View of Each Level

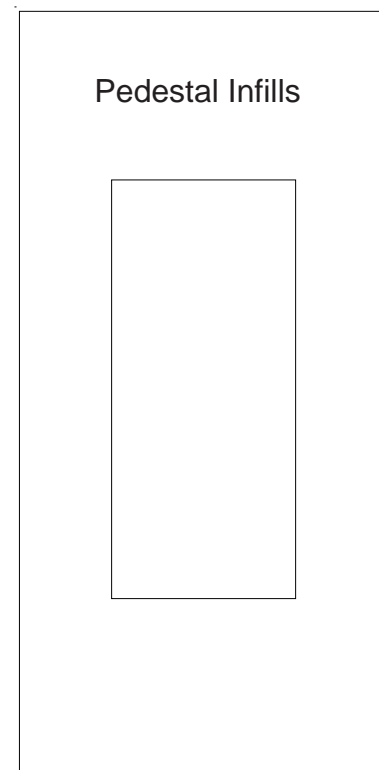

WHEN DISASSEMBLING TIGHTEN ALL KNOBS TO PREVENT LOSS DURING SHIPPING