

WHEN DISASSEMBLING ALUMINUM EXTRUSION, TIGHTEN ALL SETSCREWS AND LOCKS TO PREVENT LOSS DURING SHIPPING

# visionary™ IDESIGNS

## Using Your Setup Instructions

The Visionary Designs Setup Instructions are created specifically for your configuration. They are laid out sequentially, including an exploded view of the entire display, and then a logical series of detailed steps to assemble the main structure and components. We encourage you to study the instructions **before** attempting to assemble your exhibit.

Each page reminds you to tighten the setscrews after disassembling your exhibit to prevent loss of the locks and setscrews (see below in RED). This is **VERY IMPORTANT**.

## Cleaning and Packing Your Display

- 1) Use care when cleaning aluminum extrusion or acrylic inserts. Use only non-abrasive cleaners.
- 2) When cleaning laminate inserts or countertops, use mild cleansers and a soft material such as cotton.
- 3) Keep all display components away from extreme heat and long exposure to sunlight to avoid warping and fading.
- 4) Retain all packing material. It will make re-packing much easier and will reduce the likelihood of shipping damage.



**The Tool**

Most Visionary Designs exhibits can be assembled with the supplied Hex Key Tool. Occasionally, a flat head screwdriver may be required.



**Typical Connection**



**Typical Connection (cont'd)**

Most horizontal extrusion connections have a patented expandable lock. This lock inserts into the groove of an opposing extrusion. Tightening the lock with the Hex Key Tool expands the lock and creates a strong positive connection.



**Detail B**

**Numbered Label**

Each extrusion contains a numbered label which corresponds with setup instructions. The label is located within a groove of the extrusion (when possible). With Visionary Designs the labels contain Black numbers unless otherwise specified.



**Detail C**

**Horizontal Inline Connection** (remove only one setscrew)

Remove only (1) setscrew when disassembling. Replace setscrew in extrusion after assembling it. Before packing, replace setscrew in extrusion to avoid losing it.

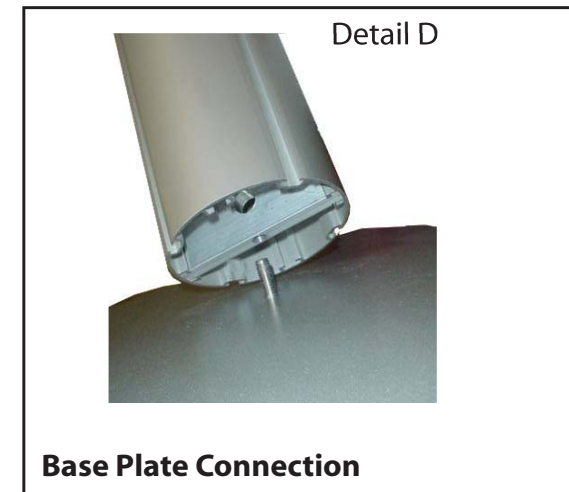

**Detail D**

**Base Plate Connection**

Attach base plate to round or square vertical extrusion using the bolt provided. Be careful not to strip the threads.

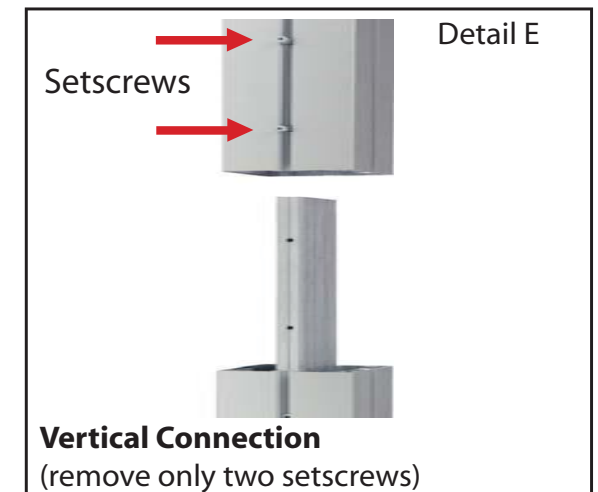

**Detail E**

**Vertical Connection**  
(remove only two setscrews)

When vertical extrusions are packed in portable cases rather than crates or tubs, they must be broken down into smaller sections which then require assembly.

Remove only (2) setscrews when disassembling. Replace setscrews in extrusion after assembling it. Before packing, replace setscrews in extrusion to avoid losing them.

**WHEN DISASSEMBLING ALUMINUM EXTRUSION, TIGHTEN ALL SETSCREWS AND LOCKS TO PREVENT LOSS DURING SHIPPING**

866.652.2100

Part Number	Qty for Step	Description
1	2	Base Plates
2	2	42" h Lower Vertical extrusion
3	2	42" h Middle Vertical extrusion
4	2	35.75" h Upper Vertical extrusion
5	2	42" h Lower Vertical extrusion
6	2	42" h Middle Vertical extrusion
7	2	35.75" h Upper Vertical extrusion
8	2	14.189" w Horizontal extrusion
8A	2	14.189" w Horizontal Assembled extrusion

Steps

- 1) Connect Vertical extrusions [2 to 3 to 4] and [5 to 6 to 7] then attach assembled verticals to base plates, refer to Detail D on General Info page.
- 2) Attach Horizontal extrusions [8 and 8A] between vertical assemblies as shown.

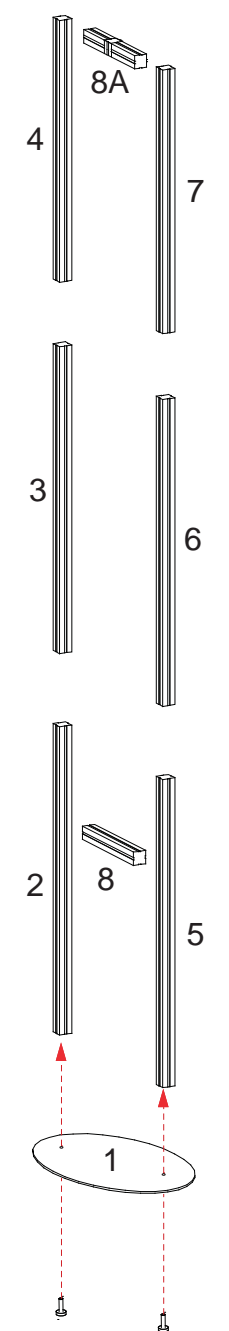
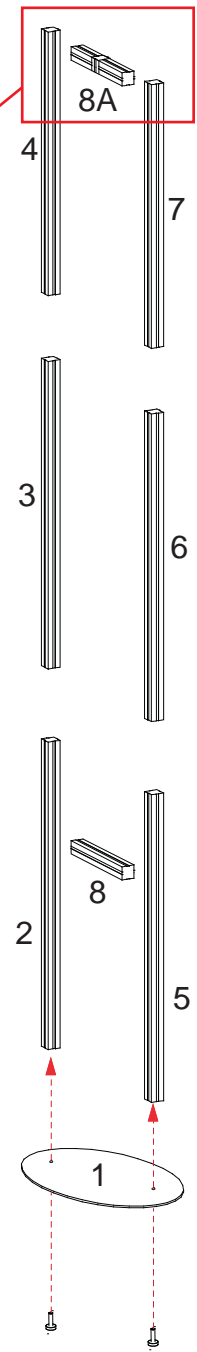
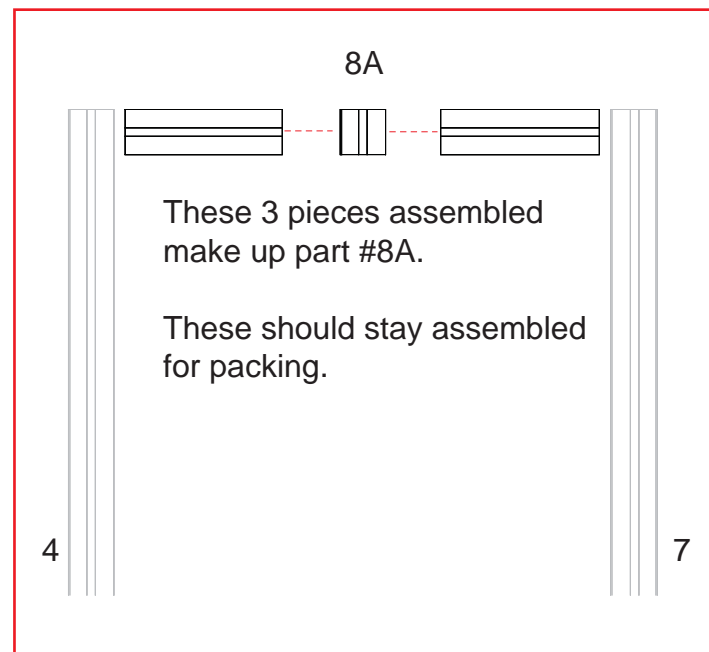

WHEN DISASSEMBLING ALUMINUM EXTRUSION, TIGHTEN ALL SETSCREWS AND LOCKS TO PREVENT LOSS DURING SHIPPING

866.652.2100

Part Number	Qty for Step	Description
9	1	48" w Horizontal extrusion
10	1	48" w Horizontal extrusion
11	1	48" w Horizontal extrusion
12	1	48" w Horizontal extrusion
13	1	16.228" w Horizontal extrusion
14	2	28.2085" w Vertical extrusion
15	2	28.2085" w Vertical extrusion
16	1	25" w Vertical extrusion
17	1	54.9779" w Curved extrusion
18	1	48" w Horizontal extrusion
19	1	48" w Horizontal extrusion
20	1	48" w Horizontal extrusion
21	1	54.9779" w Curved extrusion
22	1	25" w Vertical extrusion

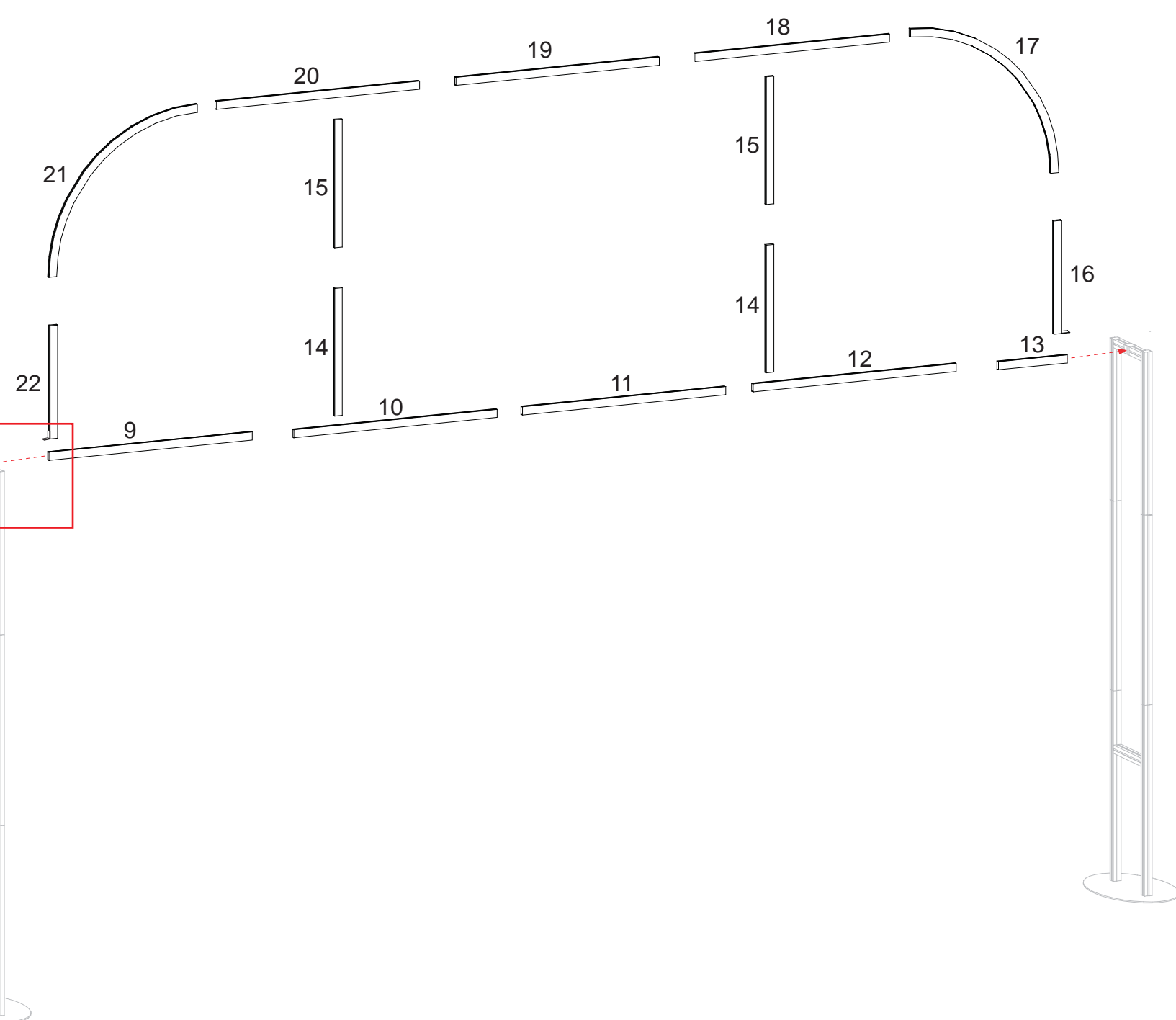

Steps

- 1) Connect horizontal extrusions [9 to 10 to 11 to 12 to 13].
- 2) Connect vertical extrusions [14 to 15] then attach to extrusions [10 and 12] as shown.
- 3) Connect extrusions [16 to 17 to 18 to 19 to 20 to 21 to 22] as shown.
- 4) Connect assembled extrusions [16 thru 22] atop and flush to ends of horizontal extrusions [9 and 13].
- 5) Place assembled Header atop assembled supports as shown in detail.

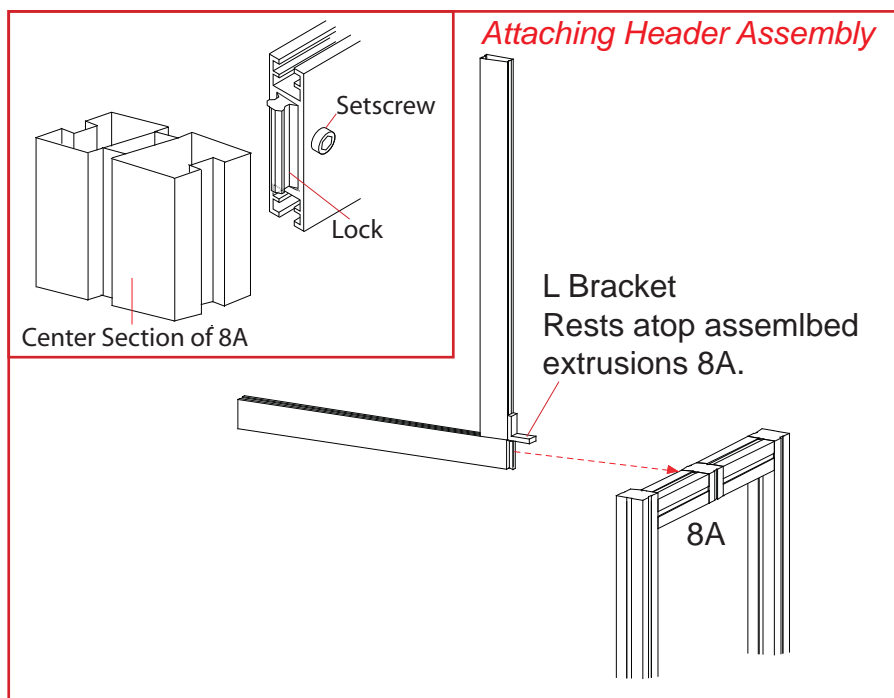

**WHEN DISASSEMBLING ALUMINUM EXTRUSION, TIGHTEN ALL SETSCREWS AND LOCKS TO PREVENT LOSS DURING SHIPPING**

**Wire Management**  
 Grey strips indicate where PR63 (wire management) is needed.  
*Note that pieces are labeled as shown on diagram.*

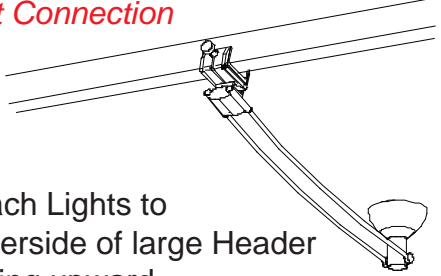
**Light Connection**  
  
 Attach Lights to underside of large Header aiming upward.

*NOTE: on clamp of light there is an label indication wether it has a long cord short cord.*

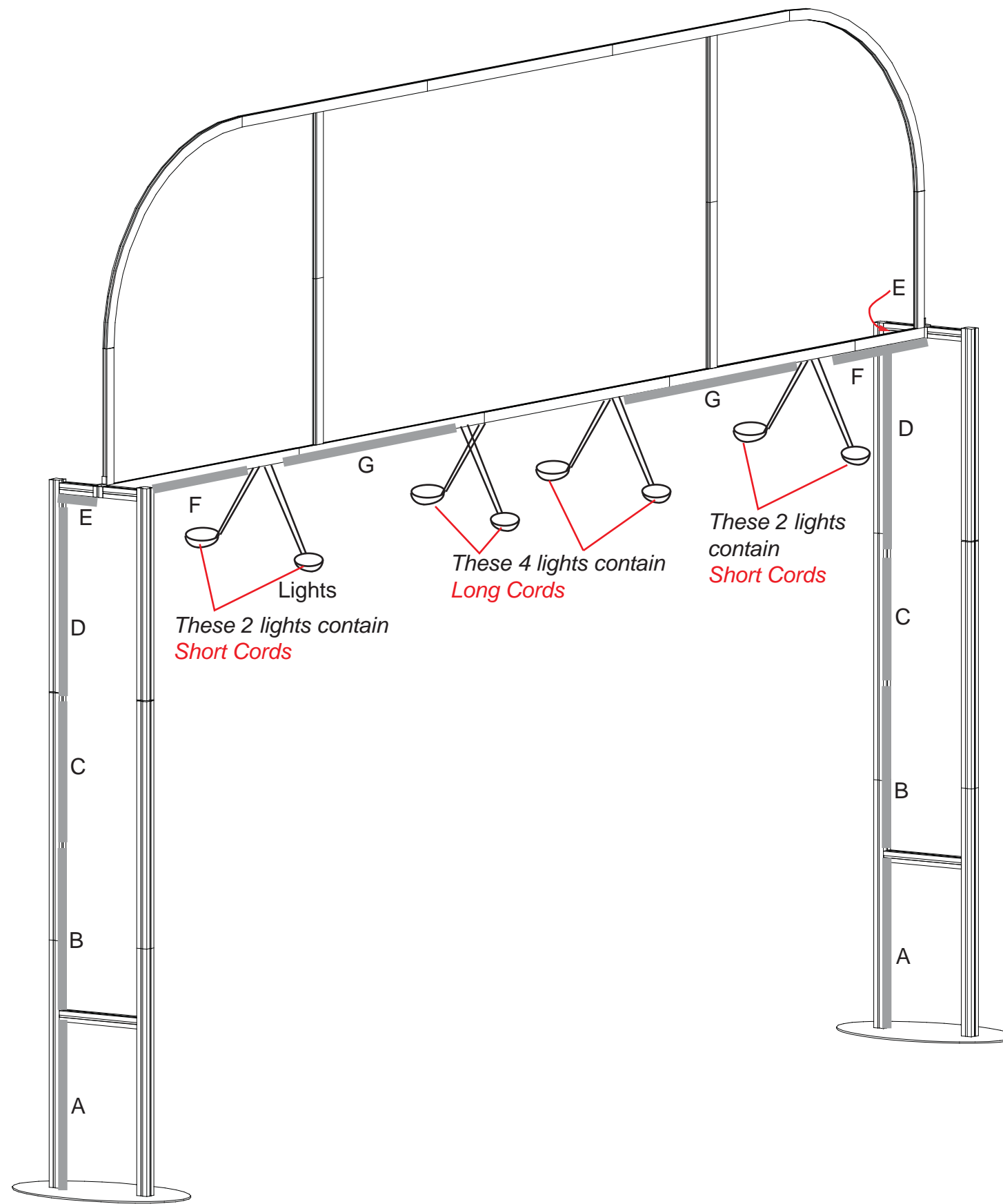

**WHEN DISASSEMBLING ALUMINUM EXTRUSION, TIGHTEN ALL SETSCREWS AND LOCKS TO PREVENT LOSS DURING SHIPPING**

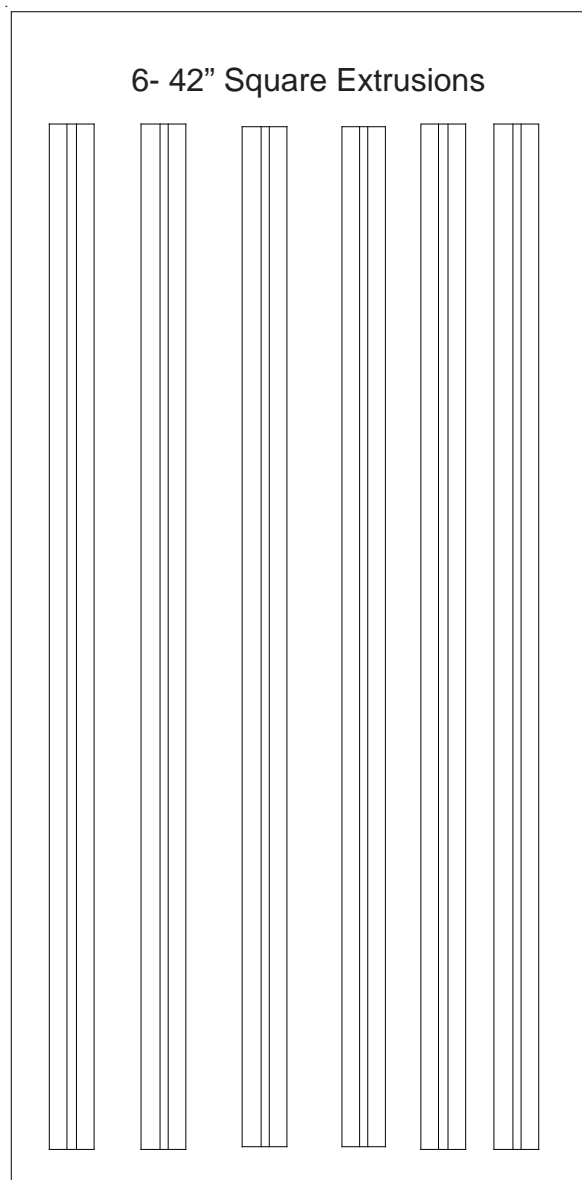

Level 1

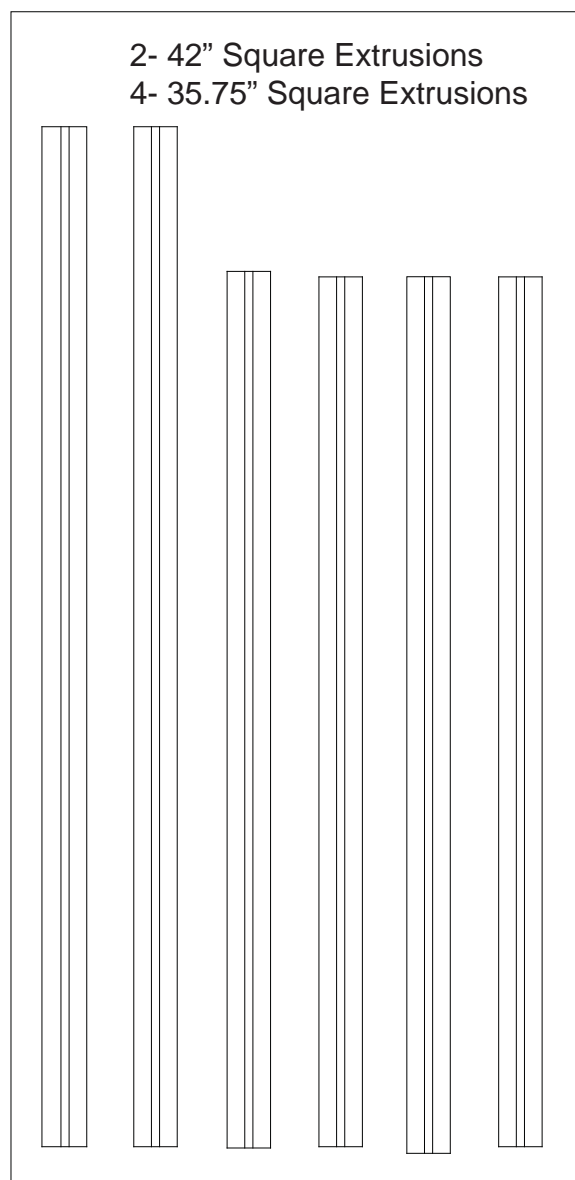

Level 2



WHEN DISASSEMBLING ALUMINUM EXTRUSION, TIGHTEN ALL SETSCREWS AND LOCKS TO PREVENT LOSS DURING SHIPPING

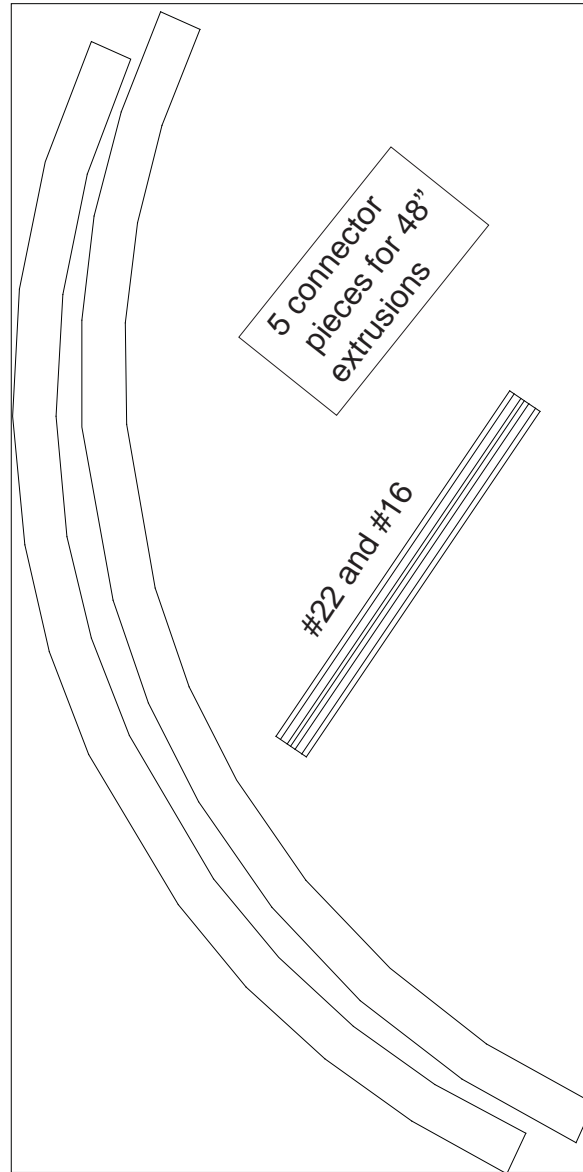

Level 1

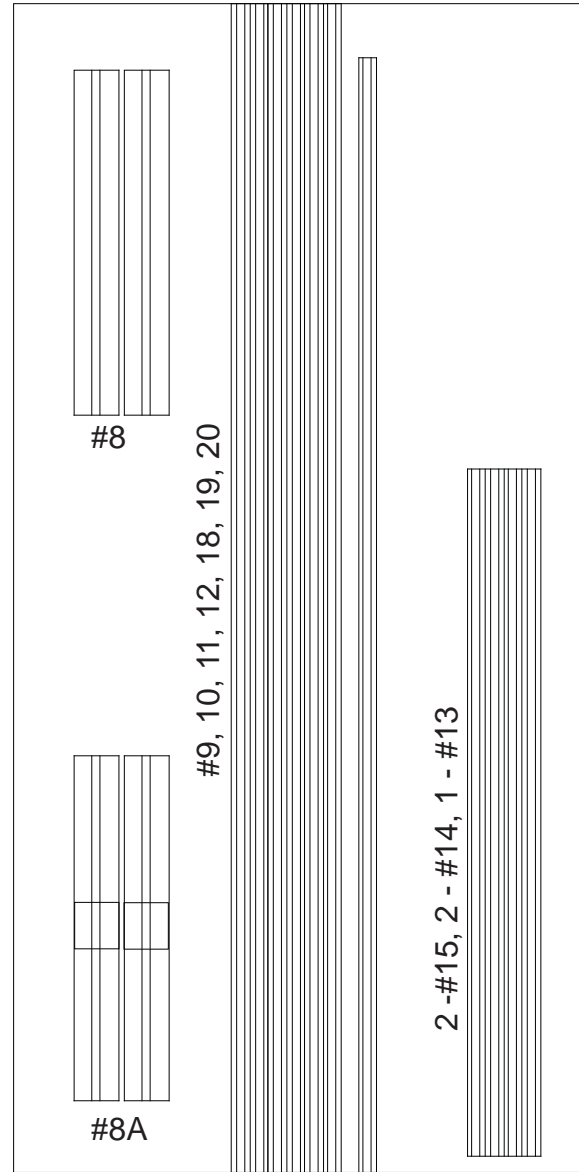

Level 2

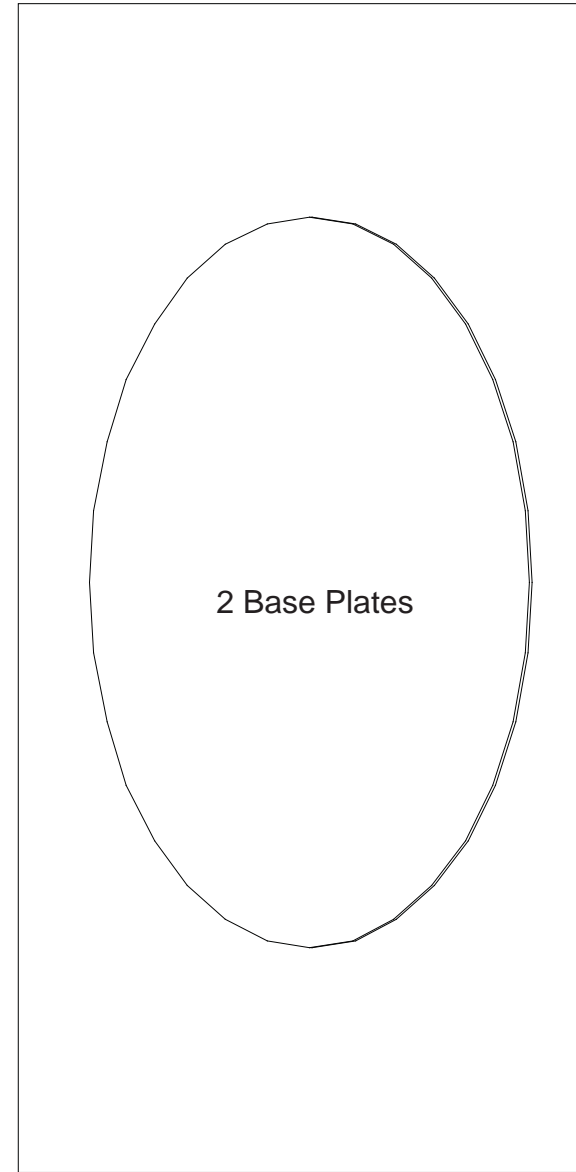

Level 3

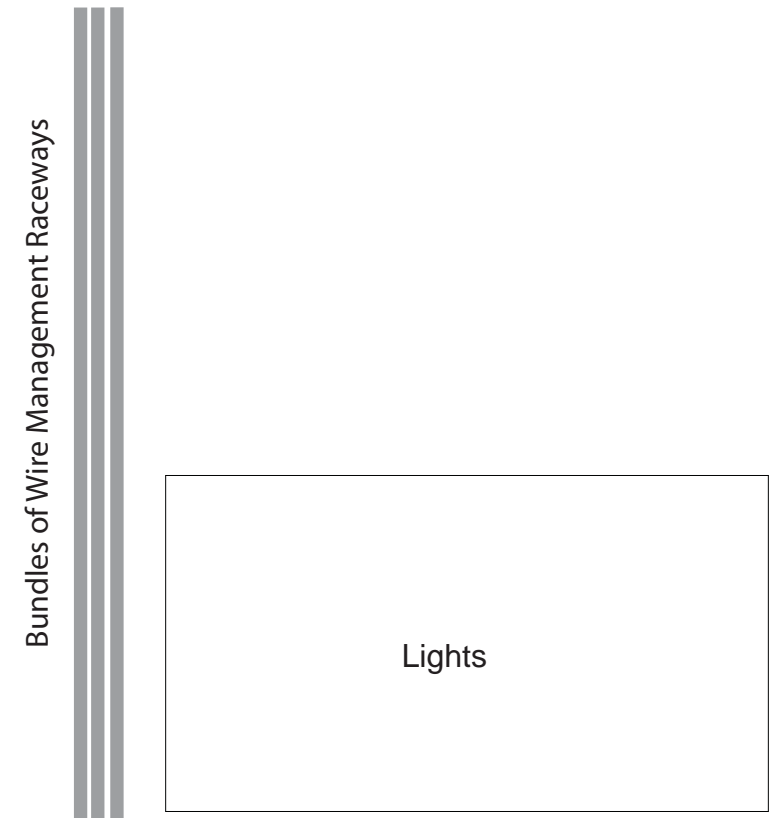

WHEN DISASSEMBLING ALUMINUM EXTRUSION, TIGHTEN ALL SETSCREWS AND LOCKS TO PREVENT LOSS DURING SHIPPING