

Plan View

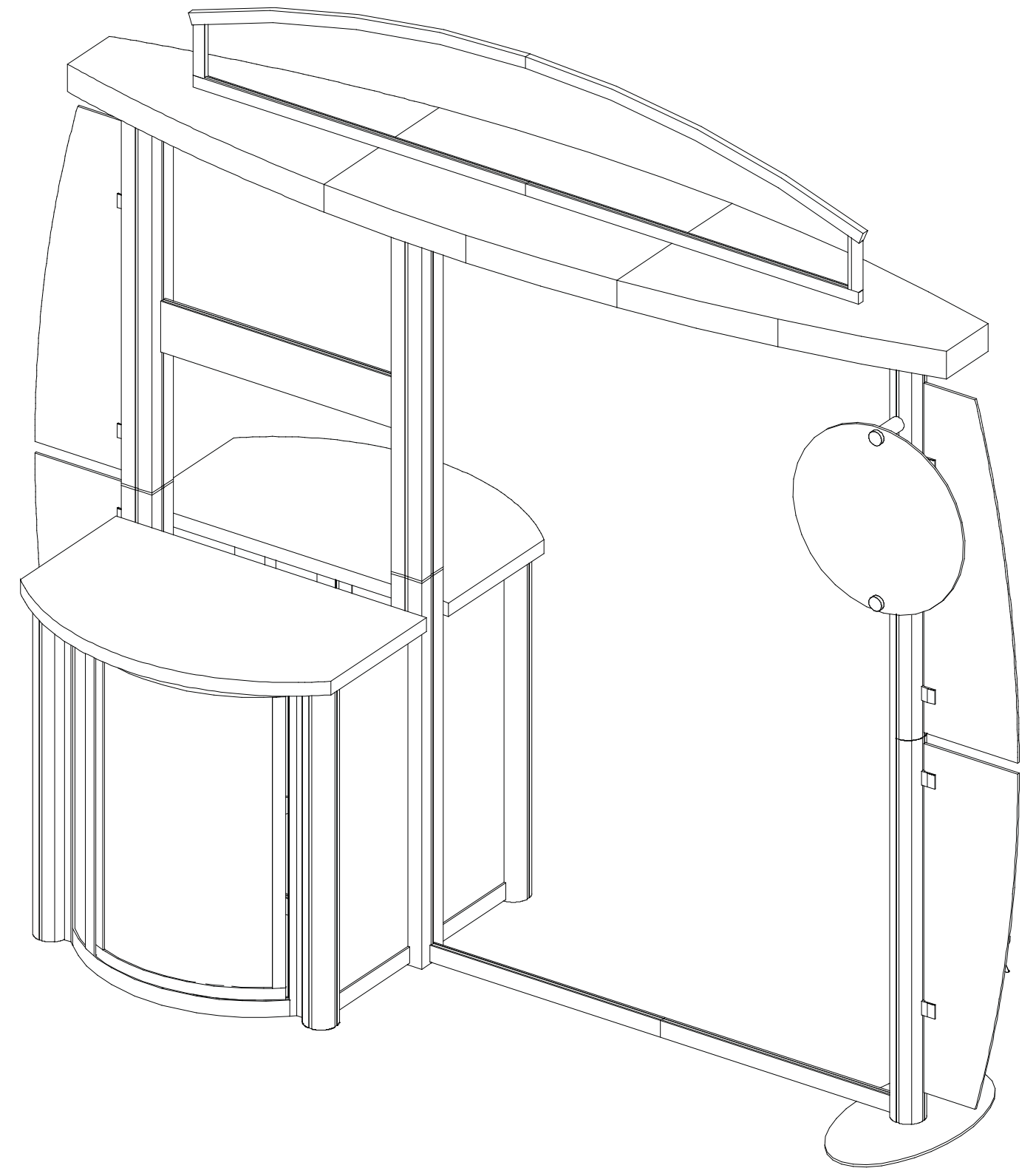

WHEN DISASSEMBLING ALUMINUM EXTRUSION, TIGHTEN ALL SETSCREWS AND LOCKS TO PREVENT LOSS DURING SHIPPING

visionary™ IDESIGNS

Using Your Setup Instructions

The Visionary Designs Setup Instructions are created specifically for your configuration. They are laid out sequentially, including an exploded view of the entire display, and then a logical series of detailed steps to assemble the main structure and components. We encourage you to study the instructions **before** attempting to assemble your exhibit.

Each page reminds you to tighten the setscrews after disassembling your exhibit to prevent loss of the locks and setscrews (see below in RED). This is **VERY IMPORTANT**.

Cleaning and Packing Your Display

- 1) Use care when cleaning aluminum extrusion or acrylic inserts. Use only non-abrasive cleaners.
- 2) When cleaning laminate inserts or countertops, use mild cleansers and a soft material such as cotton.
- 3) Keep all display components away from extreme heat and long exposure to sunlight to avoid warping and fading.
- 4) Retain all packing material. It will make re-packing much easier and will reduce the likelihood of shipping damage.



The Tool

Most Visionary Designs exhibits can be assembled with the supplied Hex Key Tool. Occasionally, a flat head screwdriver may be required.



Typical Connection

Most horizontal extrusion connections have a patented expandable lock. This lock inserts into the groove of an opposing extrusion. Tightening the lock with the Hex Key Tool expands the lock and creates a strong positive connection.



Typical Connection (cont'd)



Detail B

Numbered Label

Each extrusion contains a numbered label which corresponds with setup instructions. The label is located within a groove of the extrusion (when possible). With Visionary Designs the labels contain Black numbers unless otherwise specified.



Detail C

Horizontal Inline Connection (remove only one setscrew)

Remove only (1) setscrew when disassembling. Replace setscrew in extrusion after assembling it. Before packing, replace setscrew in extrusion to avoid losing it.

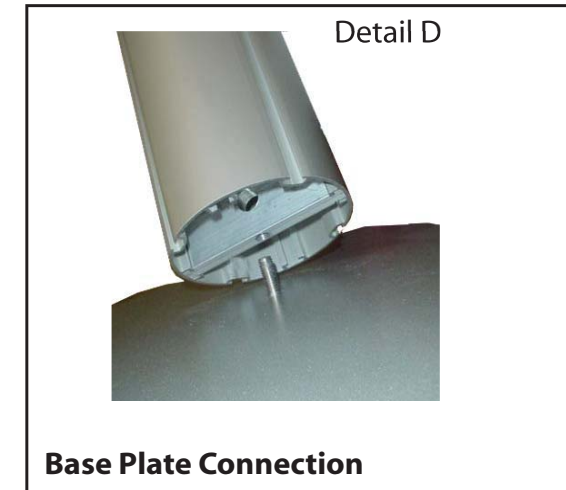

Detail D

Base Plate Connection

Attach base plate to round or square vertical extrusion using the bolt provided. Be careful not to strip the threads.

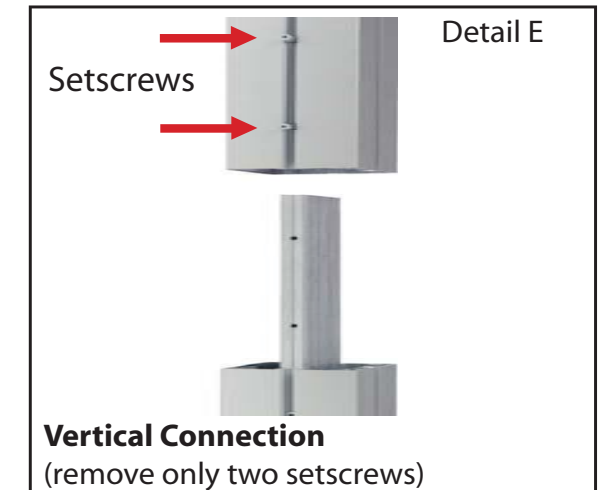

Detail E

Vertical Connection
(remove only two setscrews)

When vertical extrusions are packed in portable cases rather than crates or tubs, they must be broken down into smaller sections which then require assembly.

Remove only (2) setscrews when disassembling. Replace setscrews in extrusion after assembling it. Before packing, replace setscrews in extrusion to avoid losing them.

WHEN DISASSEMBLING ALUMINUM EXTRUSION, TIGHTEN ALL SETSCREWS AND LOCKS TO PREVENT LOSS DURING SHIPPING

Item	Qty.	Description
1	3	Oval Base Plate
2	1	42" h Lower Square Vertical Extrusion
2a	1	42" h Lower Square Vertical Extrusion
3	1	42" h Upper Square Vertical Extrusion w/ Canopy Attachment
4	1	42" h Upper Square Vertical Extrusion
5	1	42" h Lower Round Vertical Extrusion
6	1	42" h Upper Round Vertical Extrusion w/ Canopy Attachment
7	3	28" Horizontal Extrusion
8	1	28" Horizontal Extrusion w/ Velcro Attached
9a/9b	1/1	26" Horizontal w/ Velcro attached to Lower Front Edge of member
10a/10b	1/1	26" Horizontal
24	1	28" Horizontal Extrusion for Monitor Mount Attachment

Steps:

- 1) Attach lower vertical extrusion [5] to oval base plate [1], see detail D on general info page.
- 2) Attach upper vertical extrusions [3, 4 and 6] atop lower vertical extrusions [2, 2a and 5]
- 3) Connect horizontal extrusions [9A to 9B and 10A to 10B] together.
- 4) Attach horizontal extrusions [7, 8, 9A/9B, 10A/10B and 24] between vertical extrusions [2/3, 2/4 and 5/6] as shown.
- 5) Apply graphics to assembled backwall, see attaching graphic details.

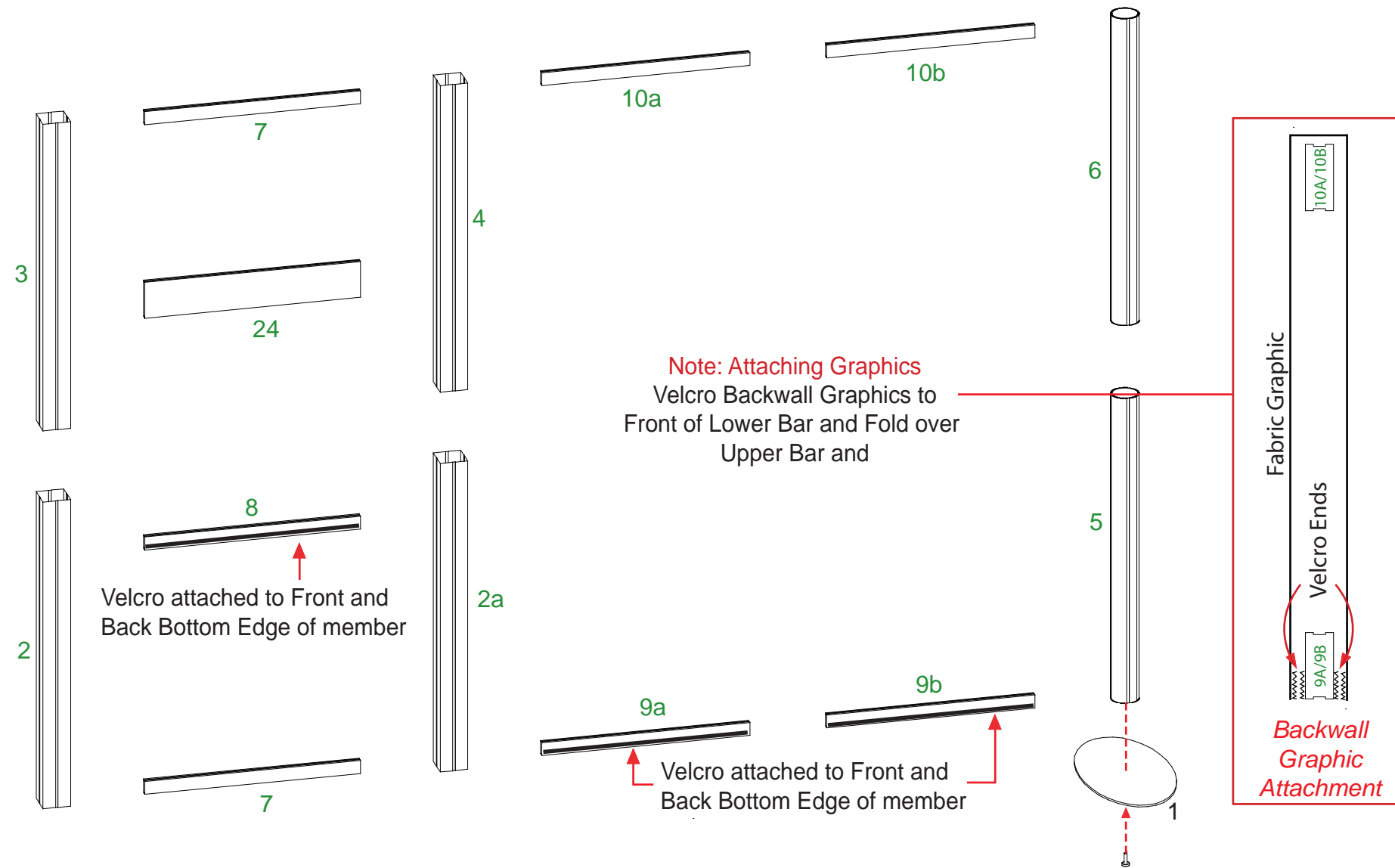
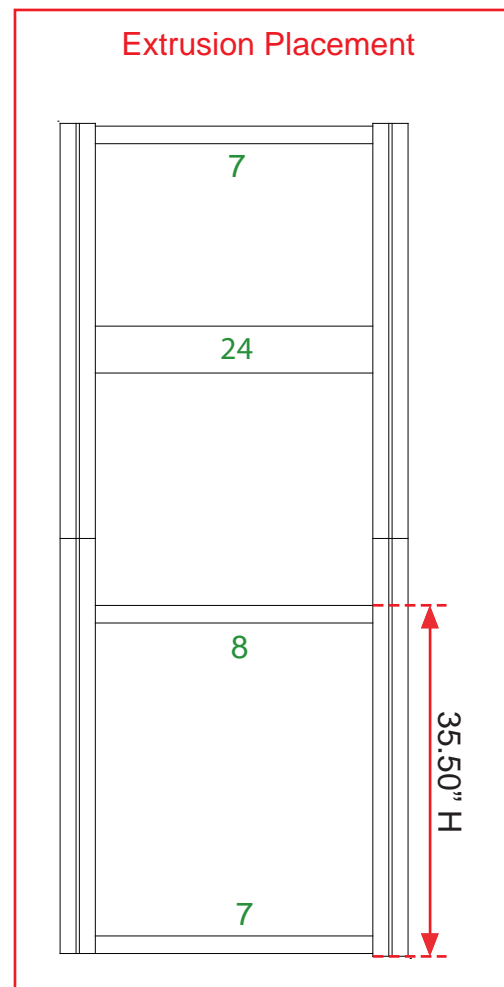
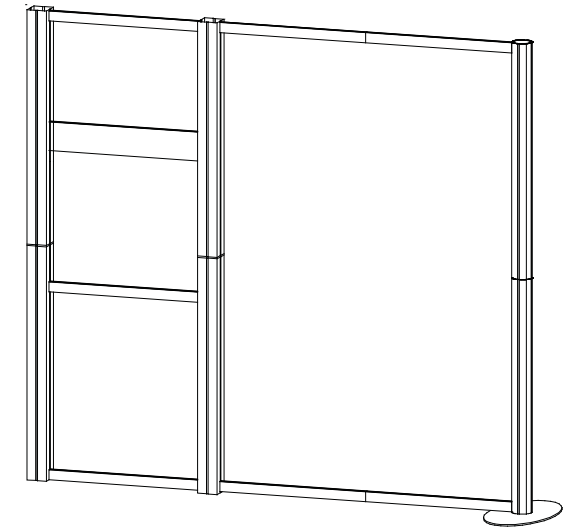

WHEN DISASSEMBLING ALUMINUM EXTRUSION, TIGHTEN ALL SETSCREWS AND LOCKS TO PREVENT LOSS DURING SHIPPING

866.652.2100

Item	Qty	Description
11	4	38" h Round Vertical Extrusion
12	2	38" h 135° Corner Extrusion
13	2	38" h 135° Corner Extrusion w/ Door Hinges
14	8	12.5" w Horizontal Extrusion
15	4	Curved Horizontal Extrusion
16	2	34.418" h Vertical Extrusion w/ Door Stopper

Steps

- 1) Attach corner extrusions [12 and 13] to vertical extrusions [11] as shown below, see Pressure Screw Attachment detail.
- 2) Attach lower horizontal extrusions [14 and 15] between vertical extrusions [2&11 and 12&13] as shown.
- 3) Attach vertical extrusions [16] to horizontal extrusion [15], leave loose, placing doors and inserts as shown, then tighten vertical extrusion [16] in place.
- 4) Place remaining inserts where indicated.
- 5) Attach upper horizontal extrusions [14 and 15] between vertical extrusions [2&11 and 12&13] as shown.
- 6) Velcro internal shelf supports to underside of assembled base, then set internal shelves atop supports.
- 7) Place counter atop assembled counter base.

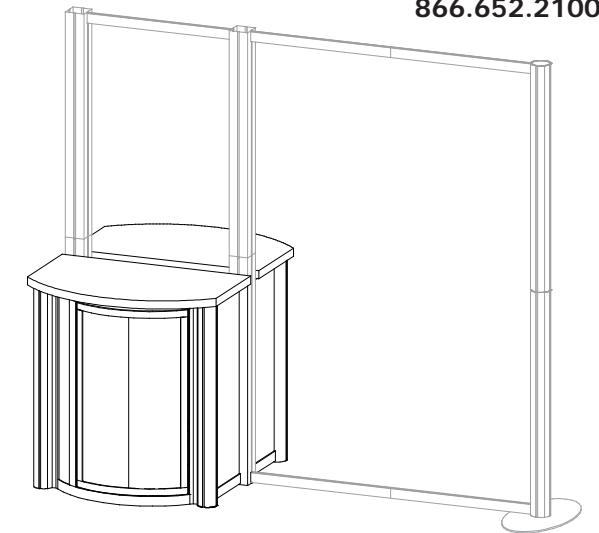

Pressure Screw Attachment

V10 Pressure Screw

Note: V10 Detail
Slide V10 Connector in between vertical extrusions [11&12 and 11&13].
Note:[11&12 and 11&13] should remain assembled when shipping.

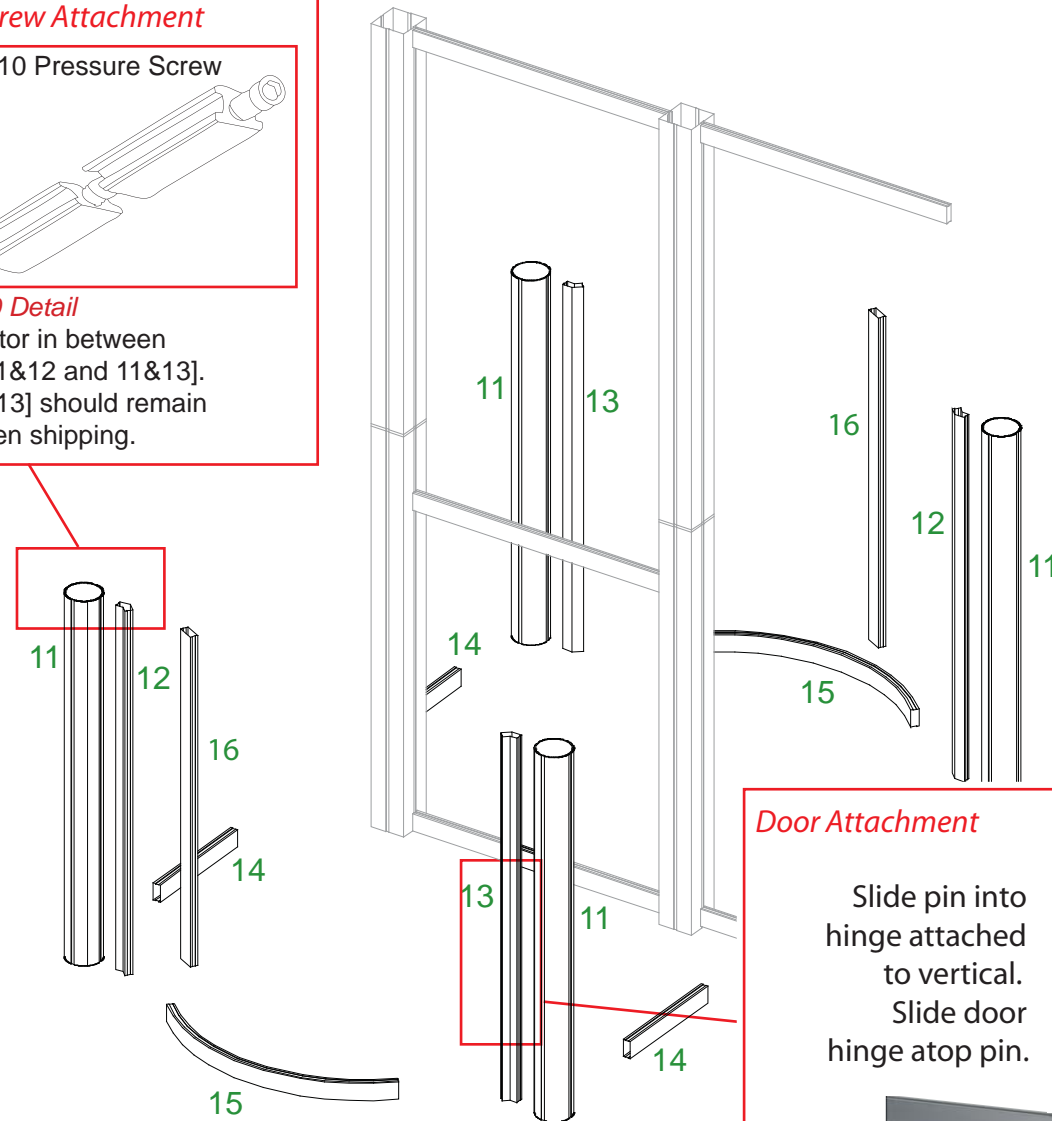
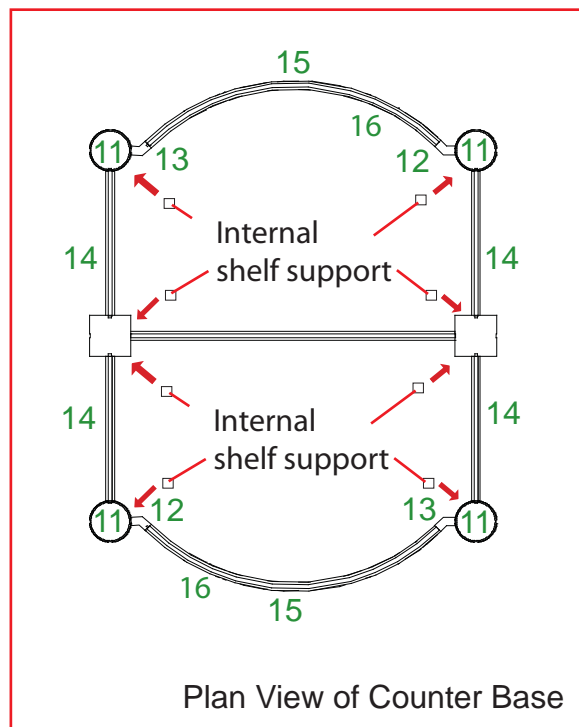

Door Attachment

Slide pin into hinge attached to vertical.
Slide door hinge atop pin.

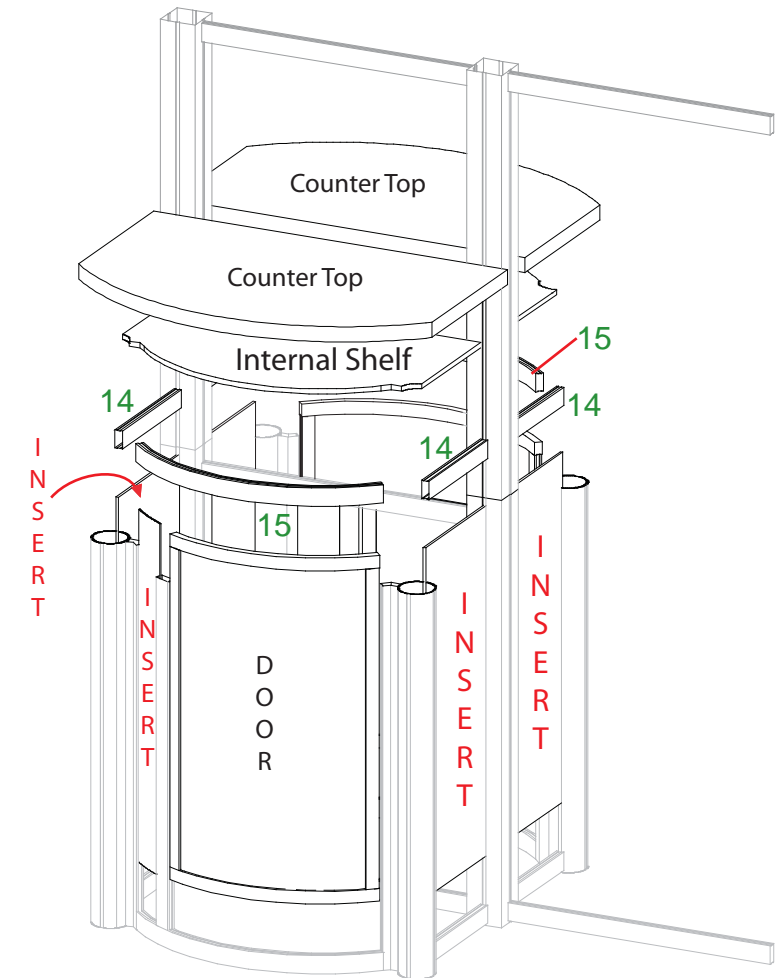

WHEN DISASSEMBLING ALUMINUM EXTRUSION, TIGHTEN ALL SETSCREWS AND LOCKS TO PREVENT LOSS DURING SHIPPING

Item	Qty.	Description
17a/17b	1	39" w Horizontal Extrusion
18	1	5.862" w Vertical Extrusion
19	1	5.862" w Vertical Extrusion
20a/20b	1	40.4" w Curved Horizontal Extrusion

Velcro Attached to outside edge of extrusion for graphic attachment.

Steps

- 1) Connect 3-piece ceiling together using bolts supplied.
- 2) Connect extrusions [17a to 17b and 20a to 20b].
- 3) Attach assembled horizontal extrusion [17a/17b] to assembled ceiling using bolts supplied.
- 4) Attach vertical extrusions [18 and 19] to left and right side of assembled horizontal extrusion [17a/17b].
- 5) Attach assembled curve horizontal extrusion [20a/20b] atop vertical extrusions [18 and 19].
- 6) Attach assembled ceiling with header frame attached to atop of assembled backwall as indicated.
- 7) Attach wings to backwall, see wing attachment.

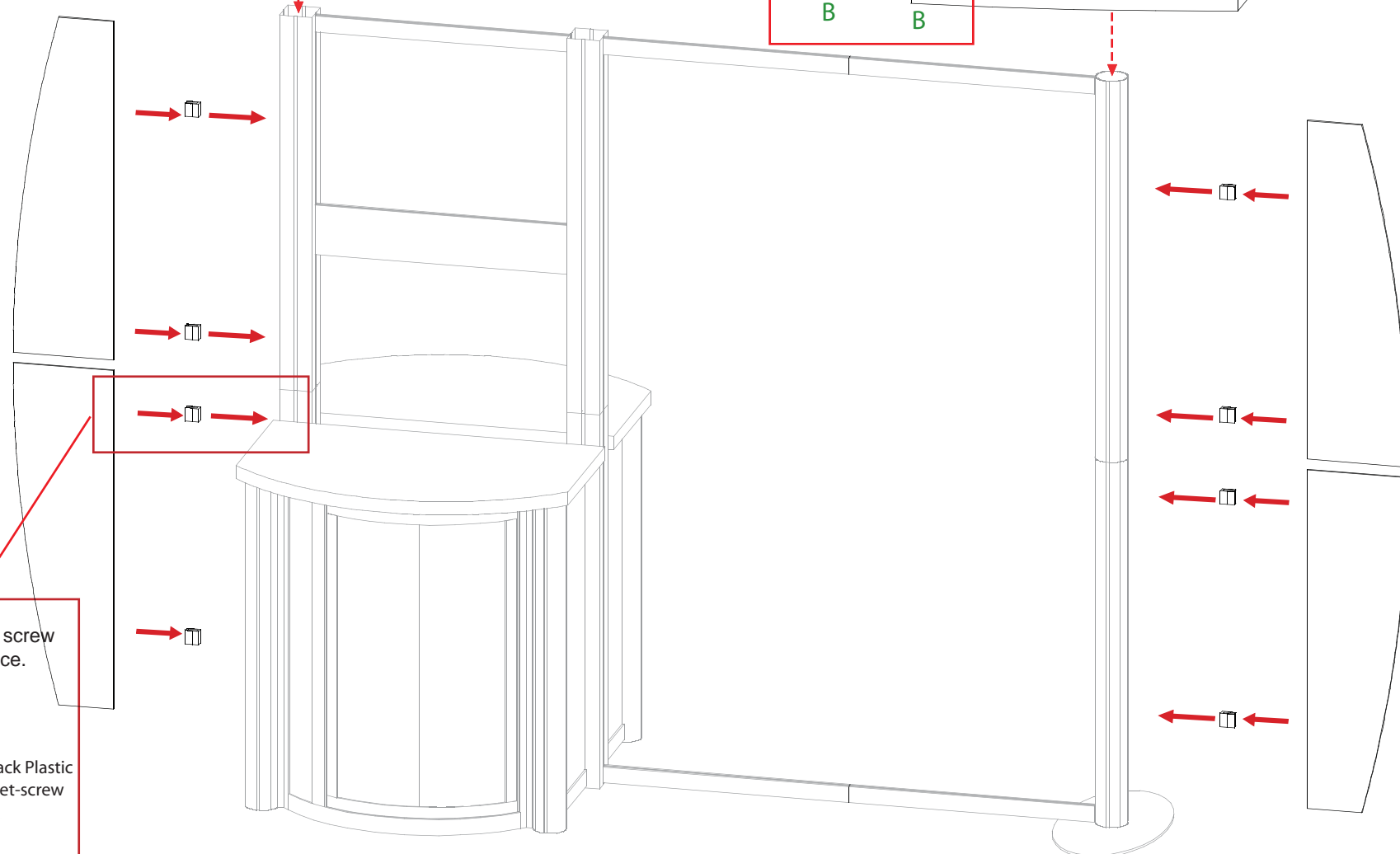
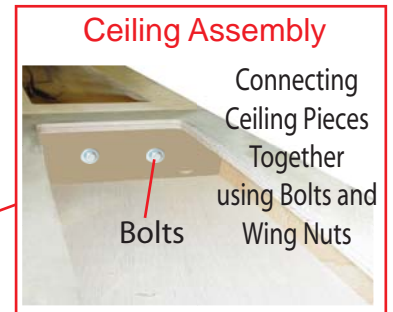
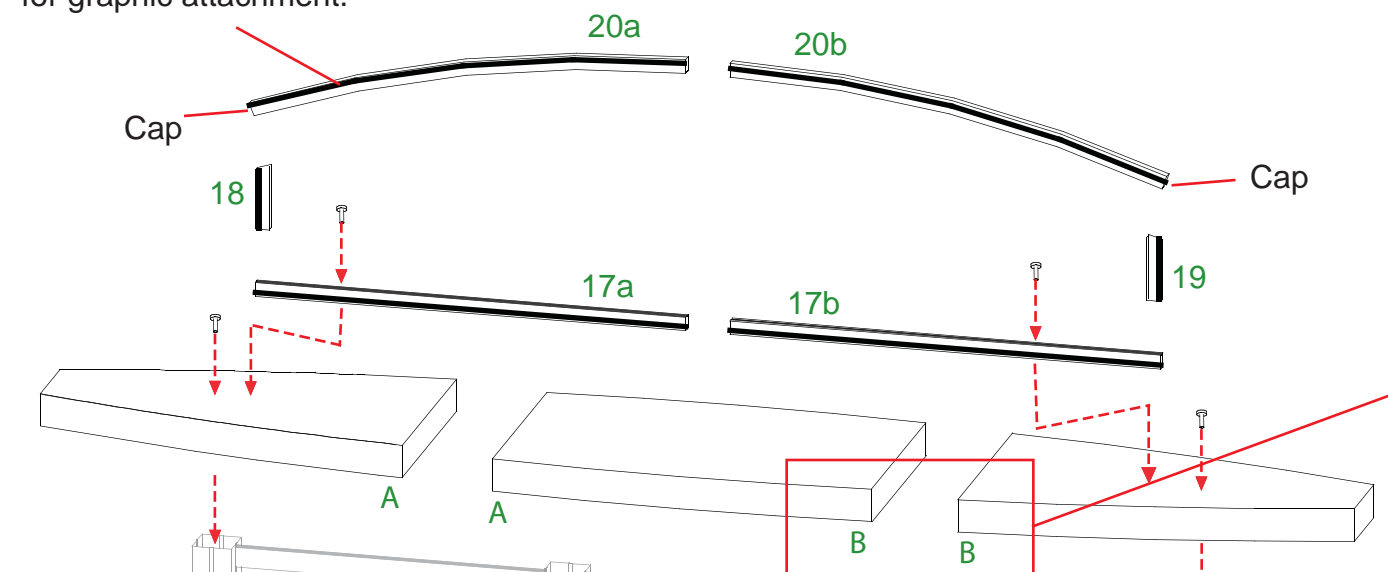

Wing Attachment

Slide A10 Clamp into groove of square extrusion.

A10

When desired location is found, tighten set screw to secure.

Set-Screw

Tighten black plastic set screw to secure Wing in place.

Black Plastic Set-screw

WHEN DISASSEMBLING ALUMINUM EXTRUSION, TIGHTEN ALL SETSCREWS AND LOCKS TO PREVENT LOSS DURING SHIPPING

Steps

- 1) Attach round signs to vertical extrusion using stand-off battels and caps.
- 2) Attach literature racks to vertical extrusion as indicated.
- 3) Attach monitor mount to assembled backwall, see monitor mount attachment.

**Monitor Mount Attachment
Option 1:**

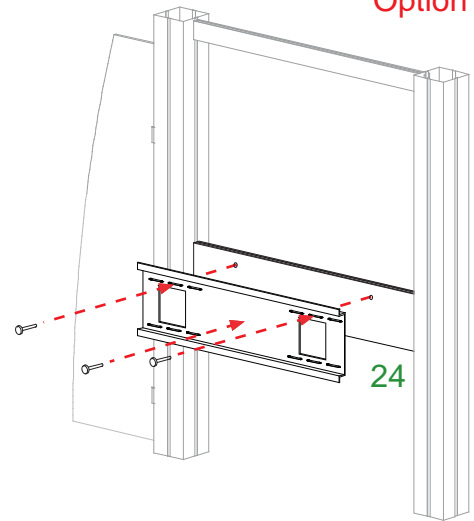

Attach wall plate to horizontal extrusion [24] using bolts provided.

Option 2: For Larger Monitor

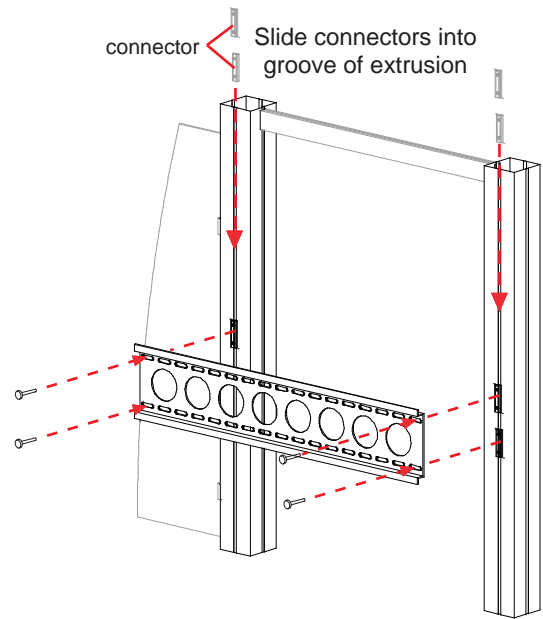

Slide connectors into groove of vertical extrusion, tighten in place. Then attach wall plate to connectors using bolts provided.

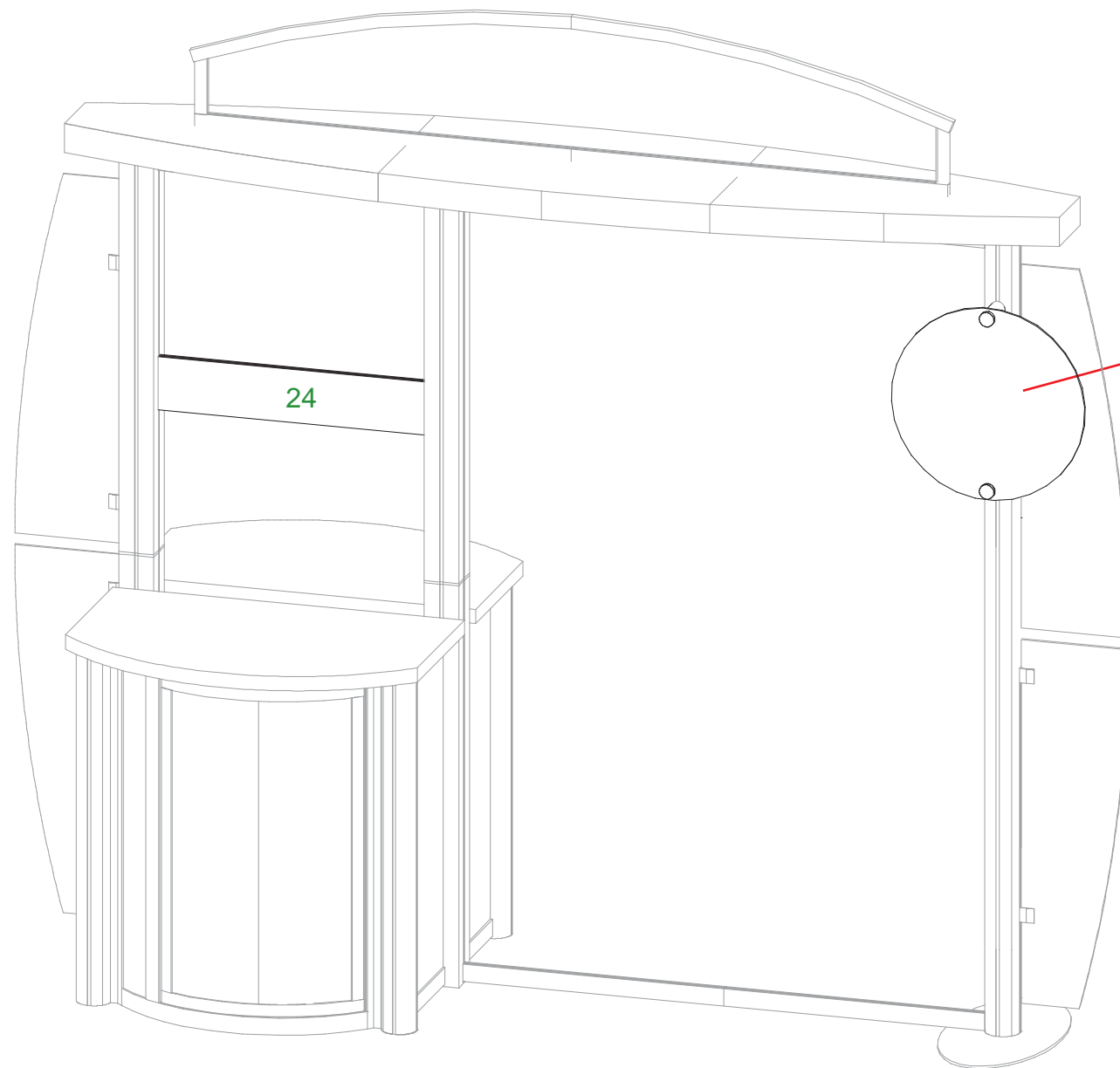

Sign Attachment



Slide stand off barrels into groove of backwall extrusion

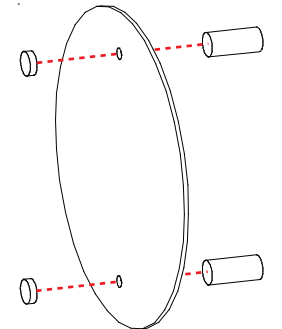

Secure Sign to stand off barrels using stand off caps

WHEN DISASSEMBLING ALUMINUM EXTRUSION, TIGHTEN ALL SETSCREWS AND LOCKS TO PREVENT LOSS DURING SHIPPING

Top View of each Level

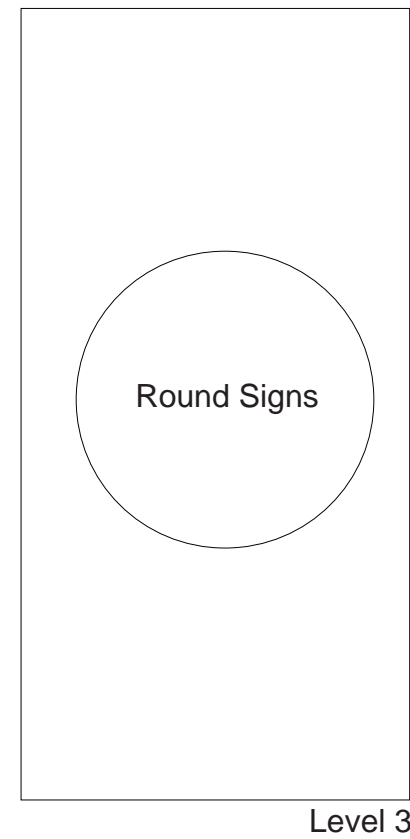
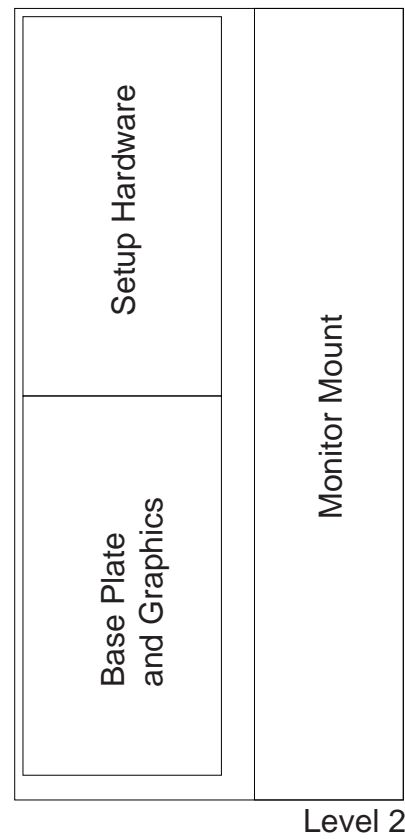
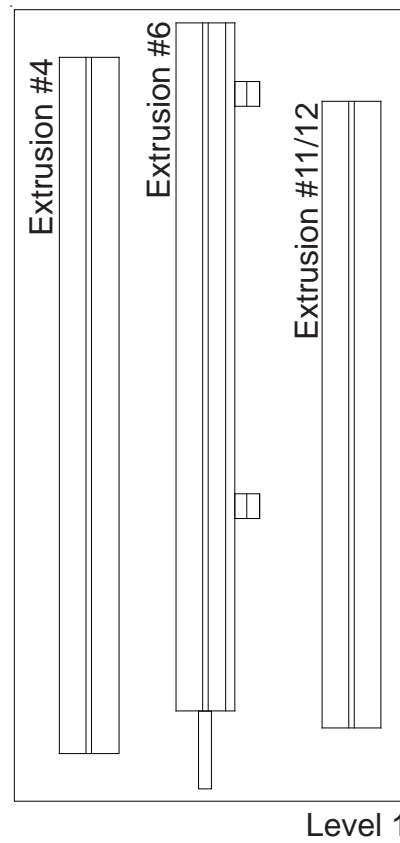

WHEN DISASSEMBLING ALUMINUM EXTRUSION, TIGHTEN ALL SETSCREWS AND LOCKS TO PREVENT LOSS DURING SHIPPING

Top View of each Level

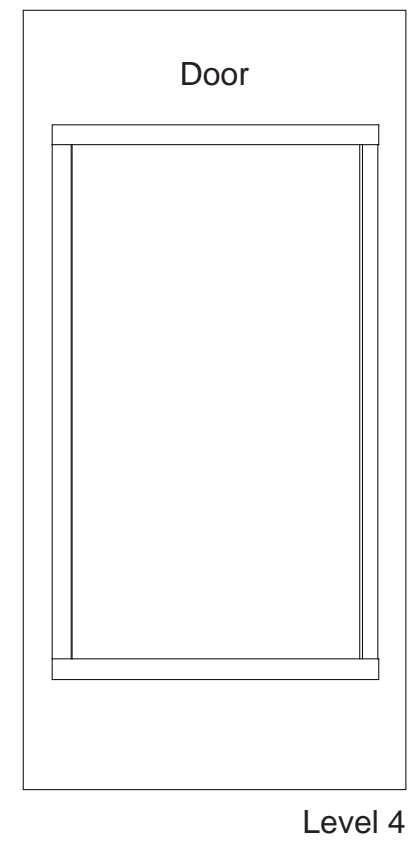
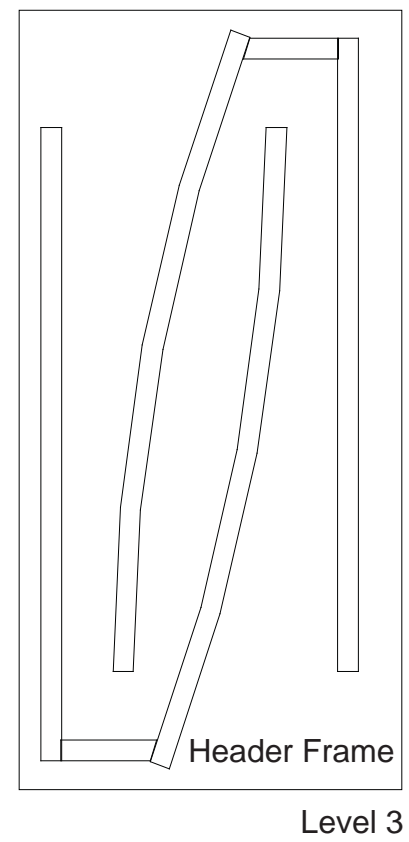
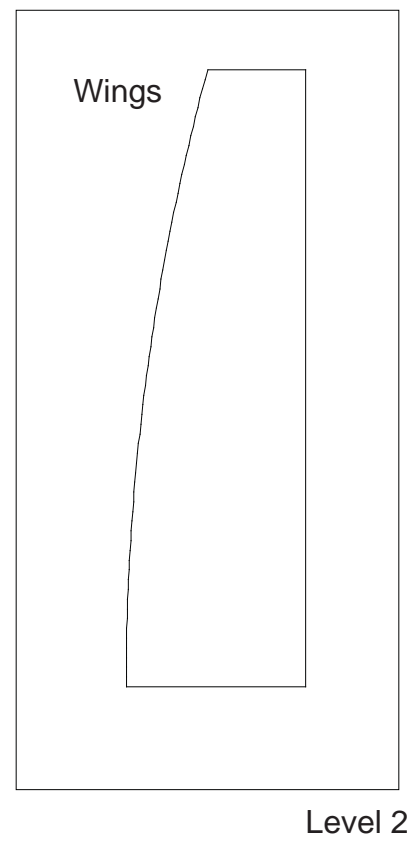
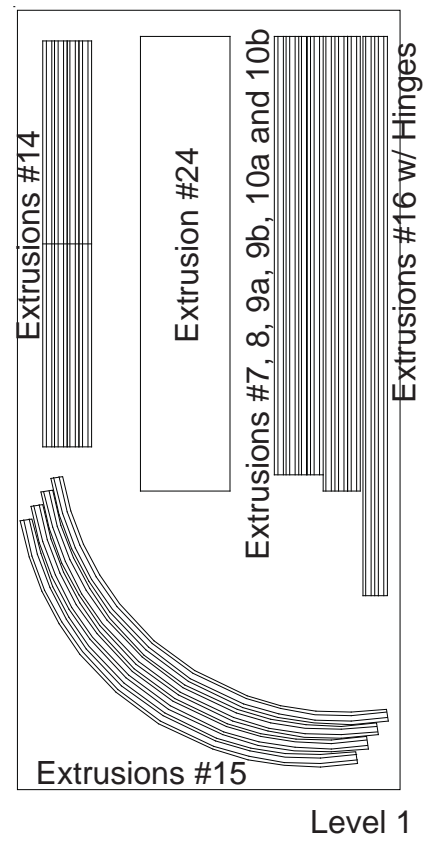

WHEN DISASSEMBLING ALUMINUM EXTRUSION, TIGHTEN ALL SETSCREWS AND LOCKS TO PREVENT LOSS DURING SHIPPING

Top View of each Level

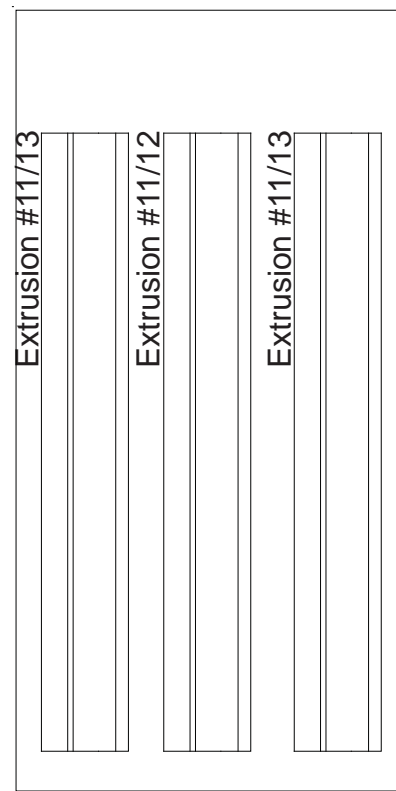

Level 1

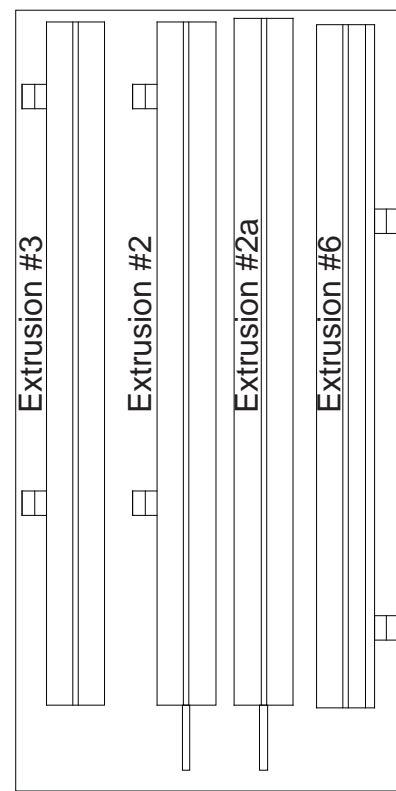

Level 2

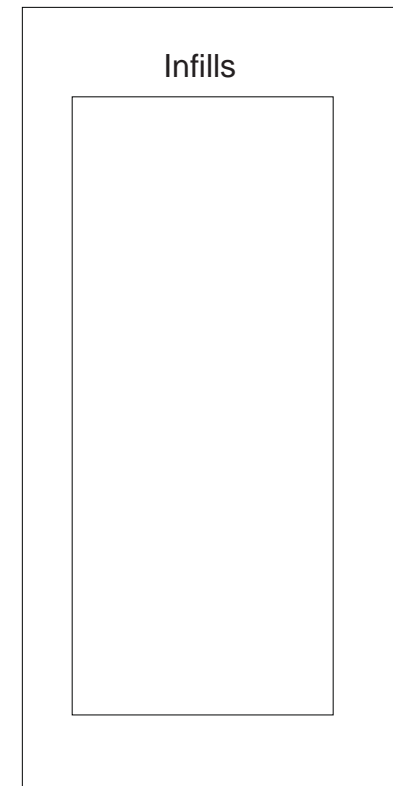

Level 3

WHEN DISASSEMBLING ALUMINUM EXTRUSION, TIGHTEN ALL SETSCREWS AND LOCKS TO PREVENT LOSS DURING SHIPPING

Top View of each Level

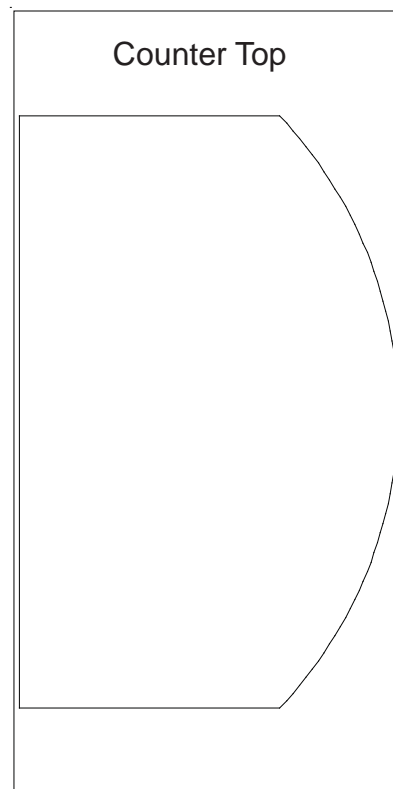

Level 1

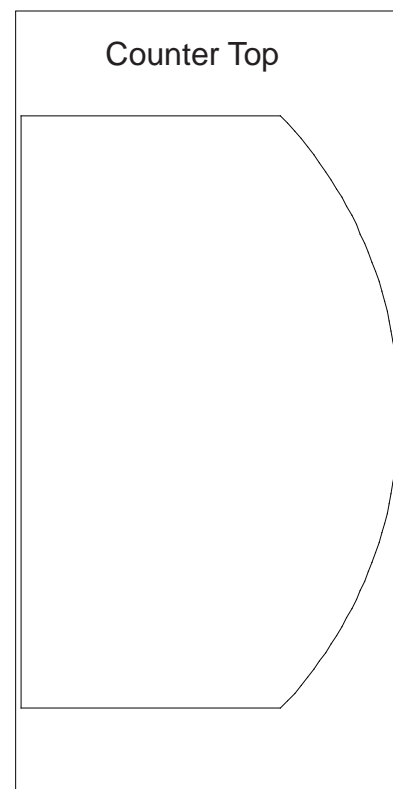

Level 2

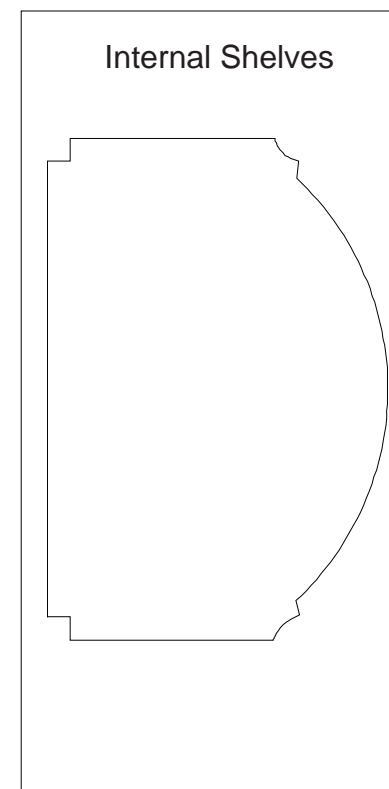

Level 3

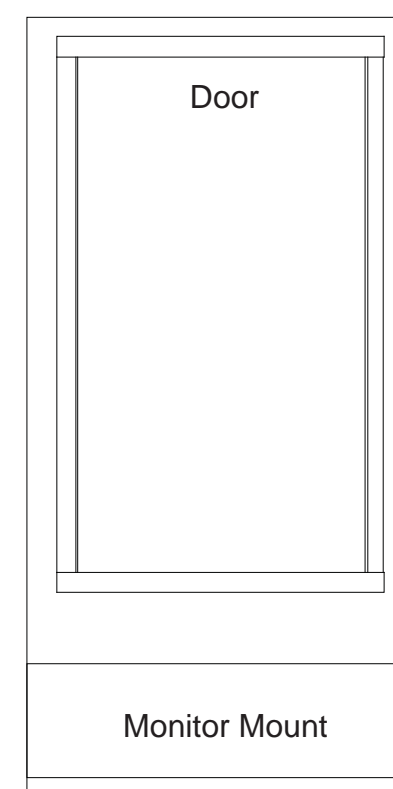

Level 4

WHEN DISASSEMBLING ALUMINUM EXTRUSION, TIGHTEN ALL SETSCREWS AND LOCKS TO PREVENT LOSS DURING SHIPPING

Top View of each Level

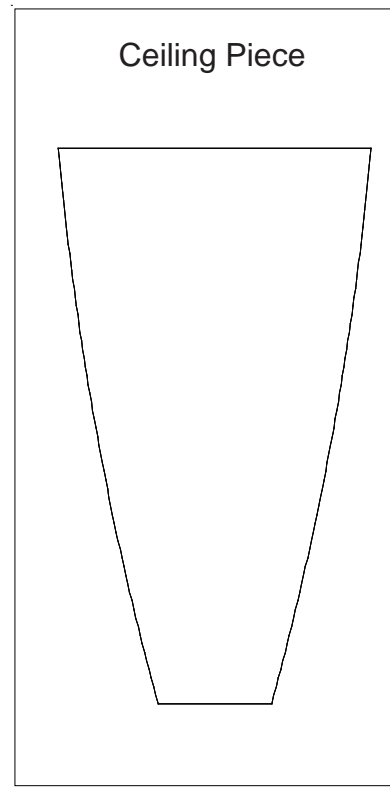

Level 1

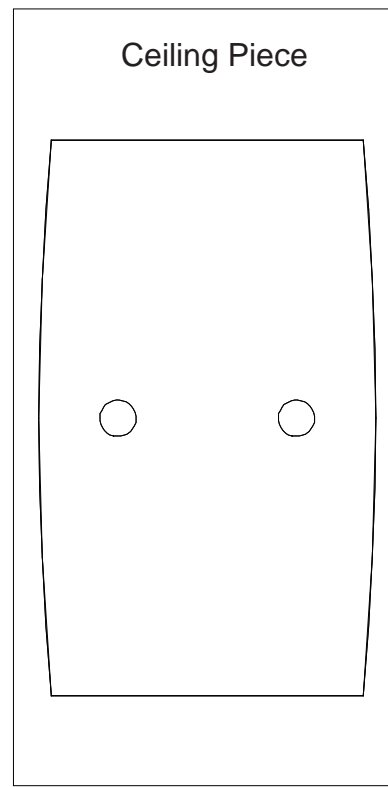

Level 2

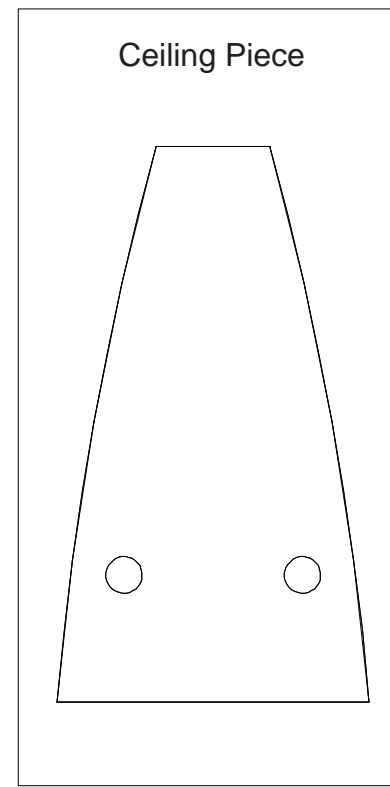

Level 3

WHEN DISASSEMBLING ALUMINUM EXTRUSION, TIGHTEN ALL SETSCREWS AND LOCKS TO PREVENT LOSS DURING SHIPPING