

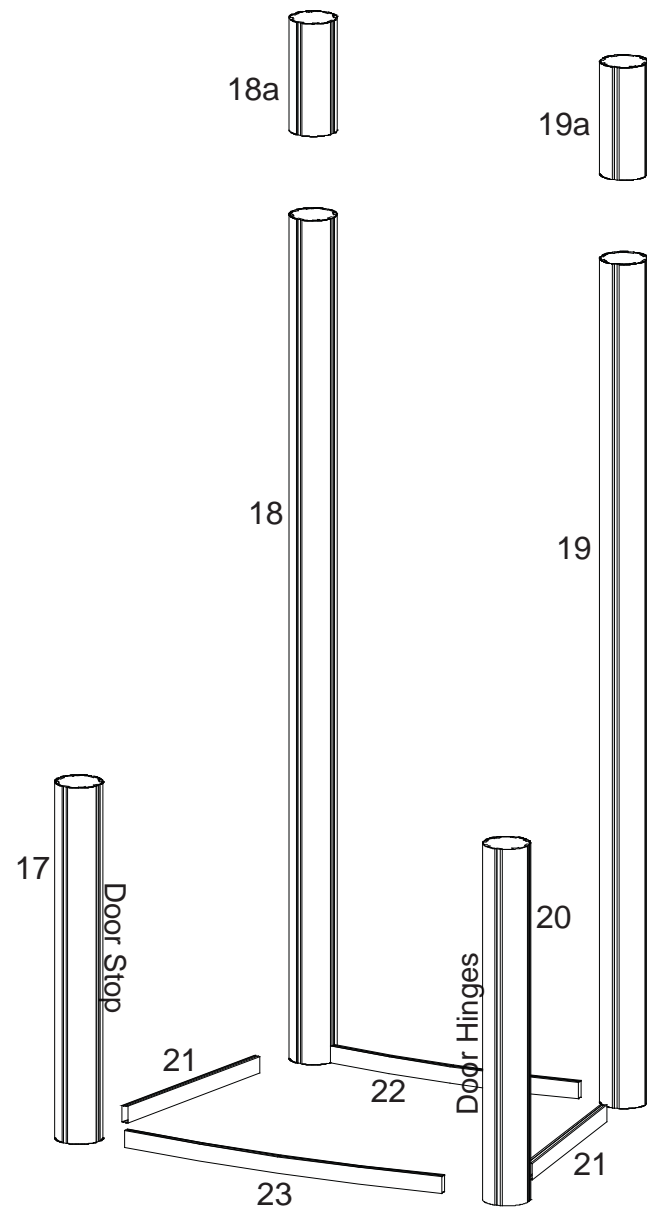

Item	Qty.	Description
17	1	38" h Vertical Extrusion w/ Door Stop
18/19	1/1	90" h Vertical Extrusion
18a/19a	1/1	12" h Vertical Extrusion
20	1	38" h Vertical Extrusion w/ Door Hinges
21	4	23" w Horizontal Extrusion
22	2	28.8199" w Curved Horizontal Extrusion
23	2	36.8477" w Curved Horizontal Extrusion
24	1	28.8199" w Curved Horizontal Extrusion

Steps:

- 1) Attach upper verticals atop lower verticals [18a to 18 and 19a to 19].
- 2) Connect lower horizontal extrusions [21, 22 and 23] between vertical extrusions [17, 18, 19 and 20].
- 3) Place infills and attach door where indicated.
- 4) Connect upper horizontal extrusions [21, 22 and 23] between vertical extrusions [17, 18, 19 and 20].
- 5) Slide counter top from top of verticals [18a and 19a] and rest atop base.
- 6) Insert upper infills between verticals and attach horizontal extrusion [24] between infills as shown.
- 7) Attach graphic to laminated header panel then hook on top of verticals [18a and 19a].



Door Attachment

Slide pin into hinge attached to vertical.
Slide door hinge atop pin.

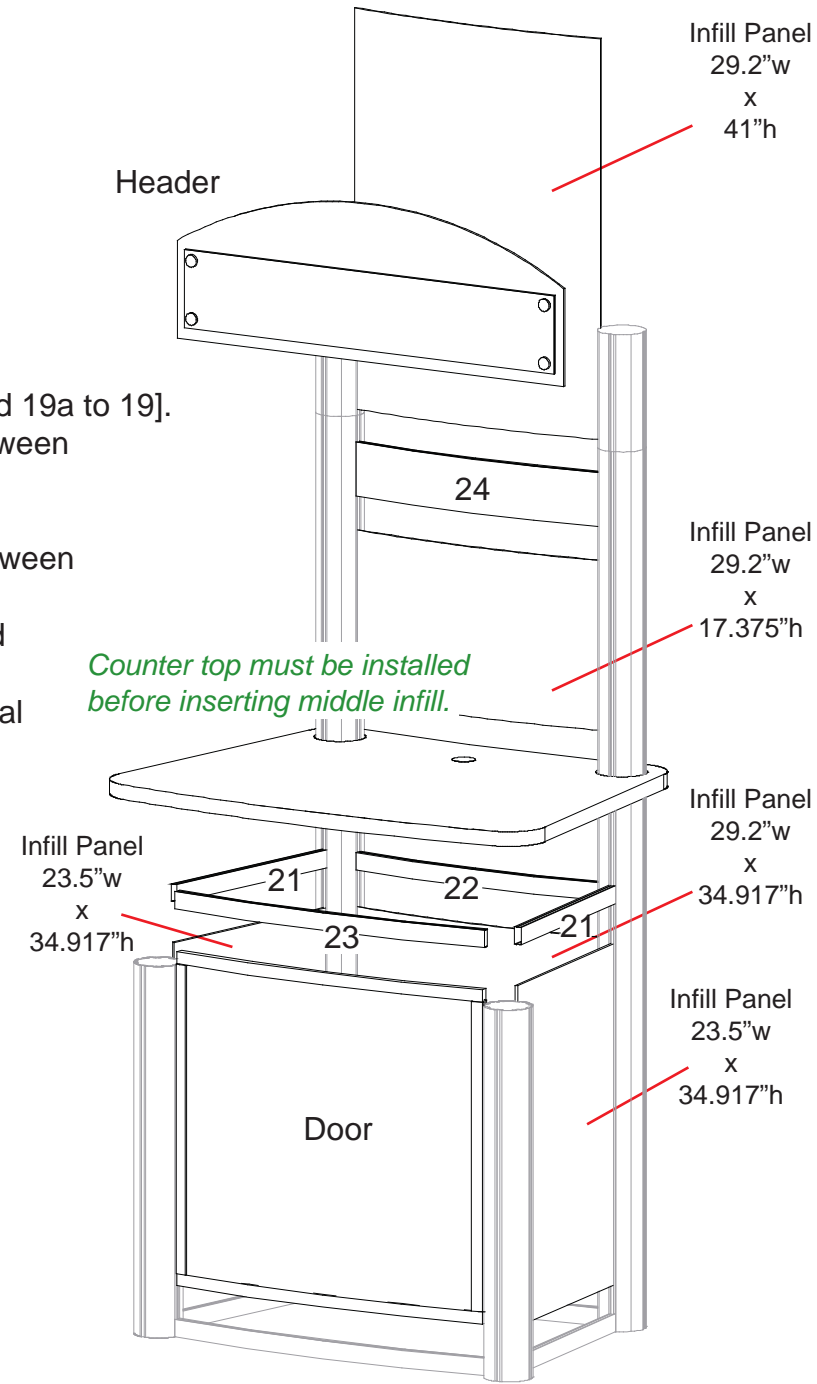

Graphic Attachment

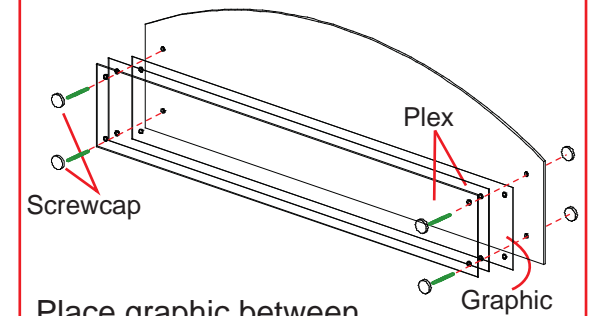

Place graphic between Plex panels then use screwcaps to secure graphic to laminated panel.

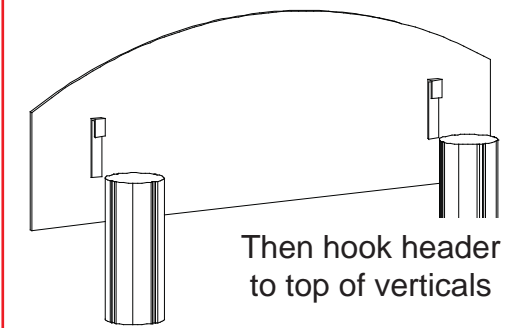

Then hook header to top of verticals

Monitor Mount Attachment

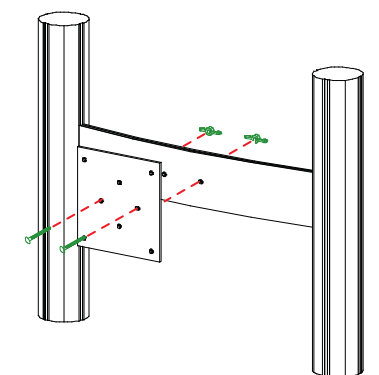

Secure wall plate to extrusion [24] using bolts and wing nuts.

WHEN DISASSEMBLING ALUMINUM EXTRUSION, TIGHTEN ALL SETSCREWS AND LOCKS TO PREVENT LOSS DURING SHIPPING

visionary™ DESIGNS

Using Your Setup Instructions

The Visionary Designs Setup Instructions are created specifically for your configuration. They are laid out sequentially, including an exploded view of the entire display, and then a logical series of detailed steps to assemble the main structure and components. We encourage you to study the instructions **before** attempting to assemble your exhibit.

Each page reminds you to tighten the setscrews after disassembling your exhibit to prevent loss of the locks and setscrews (see below in RED). This is **VERY IMPORTANT**.

Cleaning and Packing Your Display

- 1) Use care when cleaning aluminum extrusion or acrylic inserts. Use only non-abrasive cleaners.
- 2) When cleaning laminate inserts or countertops, use mild cleansers and a soft material such as cotton.
- 3) Keep all display components away from extreme heat and long exposure to sunlight to avoid warping and fading.
- 4) Retain all packing material. It will make re-packing much easier and will reduce the likelihood of shipping damage.



The Tool

Most Visionary Designs exhibits can be assembled with the supplied Hex Key Tool. Occasionally, a flat head screwdriver may be required.



Typical Connection

Most horizontal extrusion connections have a patented expandable lock. This lock inserts into the groove of an opposing extrusion. Tightening the lock with the Hex Key Tool expands the lock and creates a strong positive connection.



Typical Connection (cont'd)

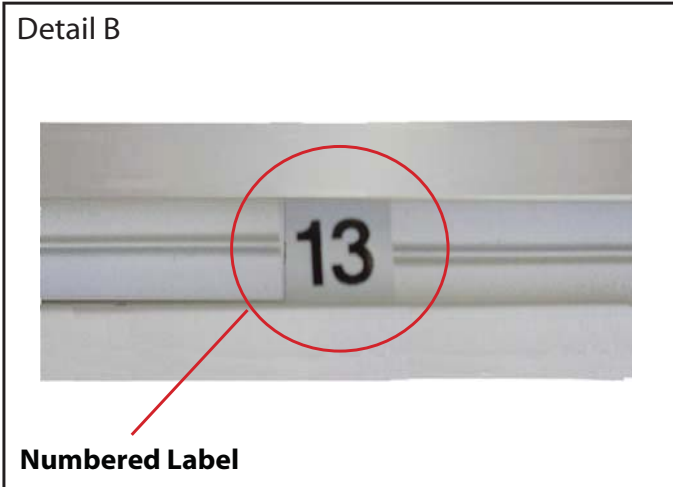

Detail B

Numbered Label

Each extrusion contains a numbered label which corresponds with setup instructions. The label is located within a groove of the extrusion (when possible). With Visionary Designs the labels contain Black numbers unless otherwise specified.



Detail C

Horizontal Inline Connection (remove only one setscrew)

Remove only (1) setscrew when disassembling. Replace setscrew in extrusion after assembling it. Before packing, replace setscrew in extrusion to avoid losing it.

NOTE :

PDF copies of your Setup Instructions are available @ www.classicexhibits.com
Use the Search Tool located on the lower left-hand corner of the Classic Home page.

Enter your 5-7 digit Order #. Search for Setup Instructions

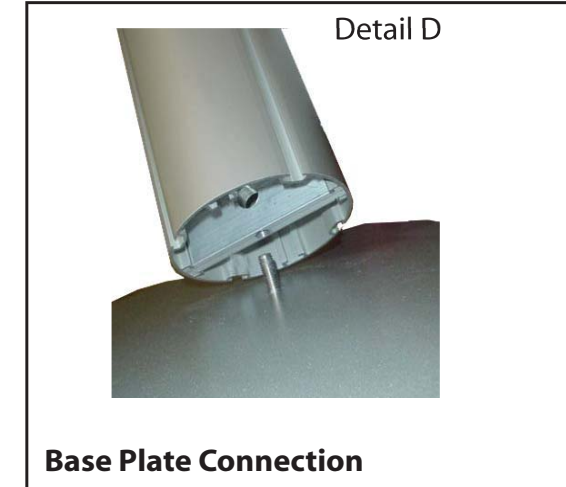

Detail D

Base Plate Connection

Attach base plate to round or square vertical extrusion using the bolt provided. Be careful not to strip the threads.

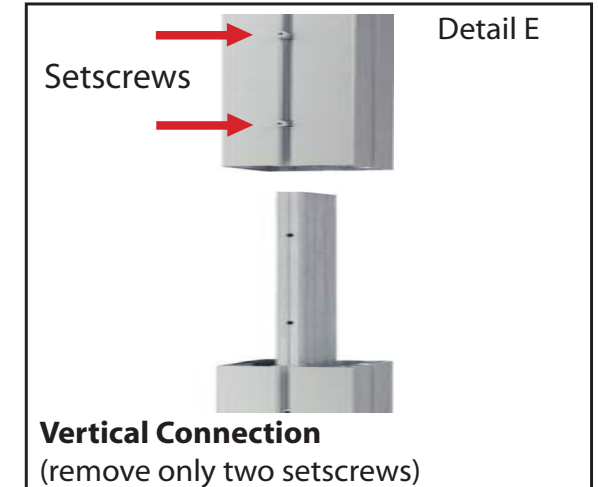

Detail E

Vertical Connection
(remove only two setscrews)

When vertical extrusions are packed in portable cases rather than crates or tubs, they must be broken down into smaller sections which then require assembly.

Remove only (2) setscrews when disassembling. Replace setscrews in extrusion after assembling it. Before packing, replace setscrews in extrusion to avoid losing them.

WHEN DISASSEMBLING ALUMINUM EXTRUSION, TIGHTEN ALL SETSCREWS AND LOCKS TO PREVENT LOSS DURING SHIPPING