

WHEN DISASSEMBLING ALUMINUM EXTRUSION, TIGHTEN ALL SETSCREWS AND LOCKS TO PREVENT LOSS DURING SHIPPING

visionary™ DESIGNS

Using Your Setup Instructions

The Visionary Designs Setup Instructions are created specifically for your configuration. They are laid out sequentially, including an exploded view of the entire display, and then a logical series of detailed steps to assemble the main structure and components. We encourage you to study the instructions **before** attempting to assemble your exhibit.

Each page reminds you to tighten the setscrews after disassembling your exhibit to prevent loss of the locks and setscrews (see below in RED). This is **VERY IMPORTANT**.

Cleaning and Packing Your Display

- 1) Use care when cleaning aluminum extrusion or acrylic inserts. Use only non-abrasive cleaners.
- 2) When cleaning laminate inserts or countertops, use mild cleansers and a soft material such as cotton.
- 3) Keep all display components away from extreme heat and long exposure to sunlight to avoid warping and fading.
- 4) Retain all packing material. It will make re-packing much easier and will reduce the likelihood of shipping damage.



The Tool

Most Visionary Designs exhibits can be assembled with the supplied Hex Key Tool. Occasionally, a flat head screwdriver may be required.



Typical Connection



Typical Connection (cont'd)

Most horizontal extrusion connections have a patented expandable lock. This lock inserts into the groove of an opposing extrusion. Tightening the lock with the Hex Key Tool expands the lock and creates a strong positive connection.

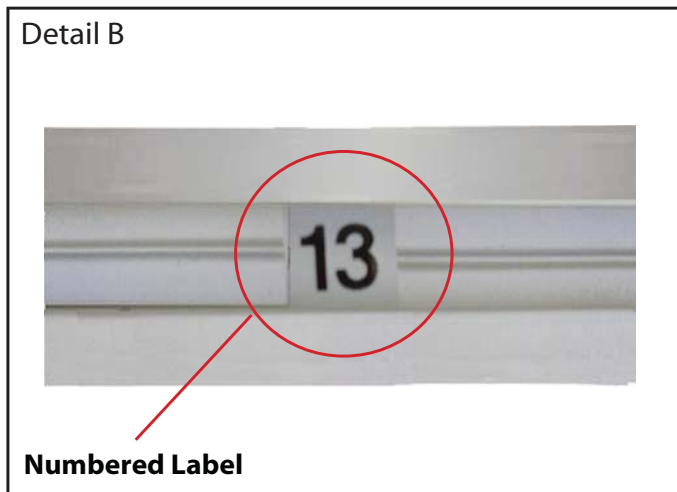

Detail B

Numbered Label

Each extrusion contains a numbered label which corresponds with setup instructions. The label is located within a groove of the extrusion (when possible). With Visionary Designs the labels contain Black numbers unless otherwise specified.



Detail C

Horizontal Inline Connection (remove only one setscrew)

Remove only (1) setscrew when disassembling. Replace setscrew in extrusion after assembling it. Before packing, replace setscrew in extrusion to avoid losing it.

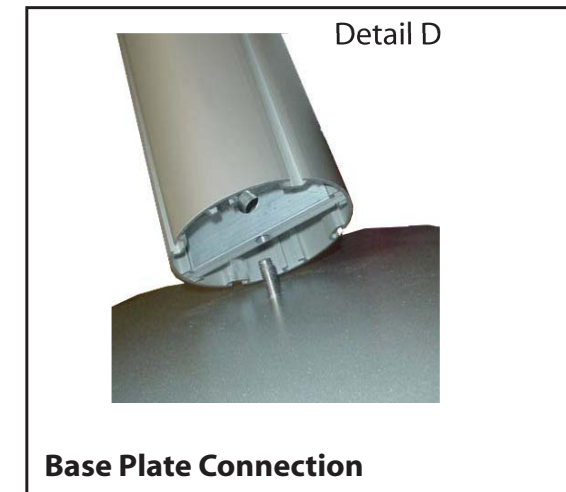

Detail D

Base Plate Connection

Attach base plate to round or square vertical extrusion using the bolt provided. Be careful not to strip the threads.

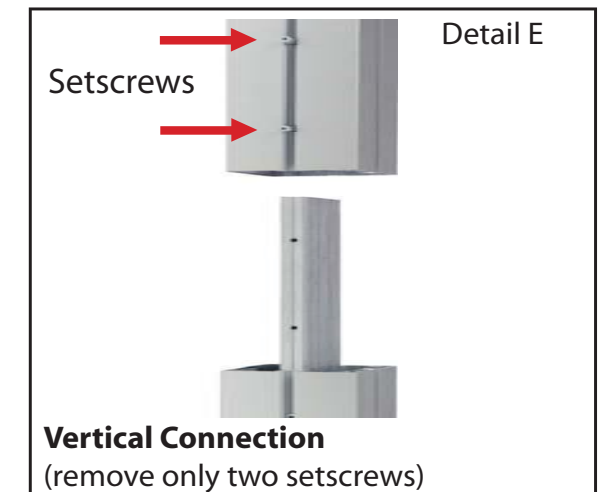

Detail E

Vertical Connection
(remove only two setscrews)

When vertical extrusions are packed in portable cases rather than crates or tubs, they must be broken down into smaller sections which then require assembly.

Remove only (2) setscrews when disassembling. Replace setscrews in extrusion after assembling it. Before packing, replace setscrews in extrusion to avoid losing them.



WHEN DISASSEMBLING ALUMINUM EXTRUSION, TIGHTEN ALL SETSCREWS AND LOCKS TO PREVENT LOSS DURING SHIPPING

Item	Qty.	Description
1	2	Base Plate
2	1	47.875"h Lower Vertical Extrusion
3	1	47.875"h Lower Vertical Extrusion
4	1	47.875"h Lower Vertical Extrusion
5	1	47.875"h Lower Vertical Extrusion
6a/6b	1/1	41"w Horizontal Extrusion
7a/7b	1/1	41"w Horizontal Extrusion
8	1	10"w Extrusion w/ Pill Slots
9	2	10"w Extrusion

Steps:

- 1) Attach lower vertical extrusions [2 and 4] to base plates [1].
- 2) Attach upper vertical extrusions to lower extrusions [3 to 2 and 5 to 4].
- 3) Connect horizontal extrusions together [6a to 6b and 7a to 7b].
- 4) Connect horizontal assemblies between vertical extrusions as shown.
- 5) Assemble shelf support by locking extrusions [9] to pill slots on extrusion [8].
- 6) Attach shelf support to backwall vertical where indicated, then set shelf atop support.
- 7) Attach monitor mount where indicated.

Connector Detail

1) Slide connector pieces into vertical extrusion and secure with screws.
2) Slide upper vertical on connectors and atop lower vertical, then secure with screws.

Keep all screws attached to connector pieces when disassembling to prevent loss

Velcro attached to upper back of horizontal bars

Velcro attached to lower back of horizontal bars

Knob Knob

Slide Connection Bar between Extrusions and tighten Knobs. ****Do not over tighten Knobs.****

A10 clamps should stay attached to vertical extrusions

A10 clamps should stay attached to vertical extrusions

Graphic Attachment
Velcro fabric graphic to back of upper and lower horizontal bars.

*** Monitor Mount Attachment**

Tighten Setscrews

Slide mounting connector pieces into groove of extrusion. Tighten setscrew to secure in place.

Attach back plate to connectors on vertical extrusion using screws. Then attach top plate and tighten setscrews to secure.

GREEN STAR indicates location of connection lock with knob.

Shelf Attachment



WHEN DISASSEMBLING ALUMINUM EXTRUSION, TIGHTEN ALL SETSCREWS AND LOCKS TO PREVENT LOSS DURING SHIPPING

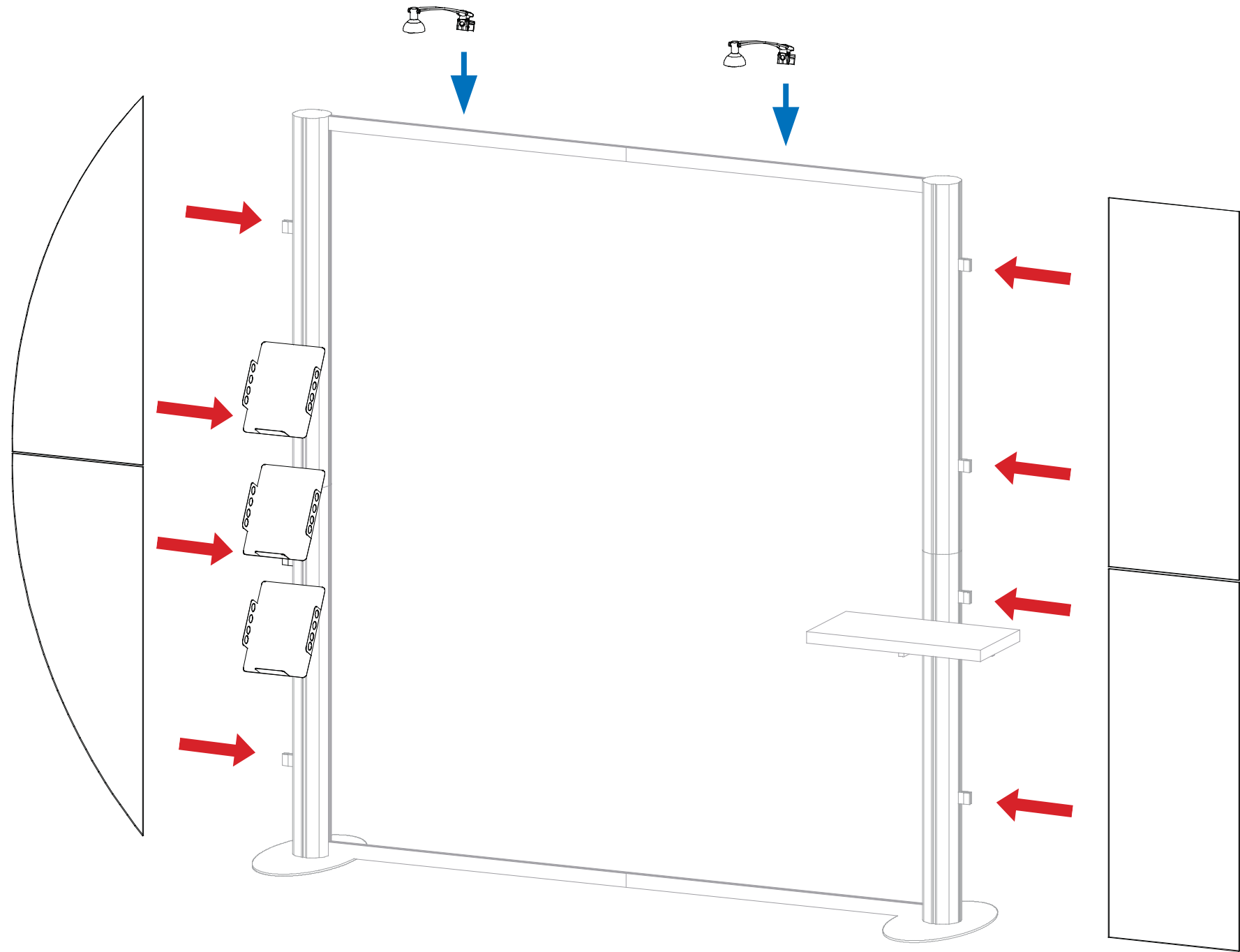
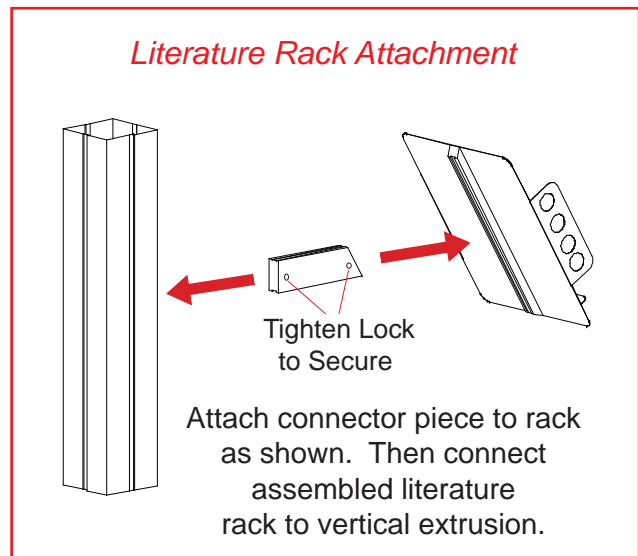
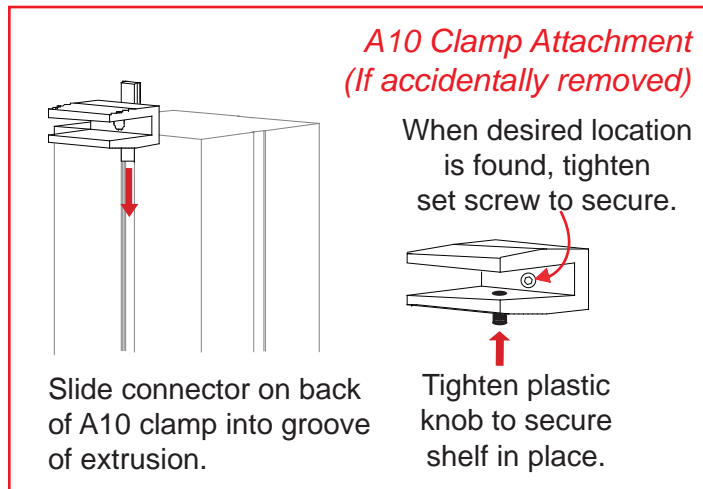
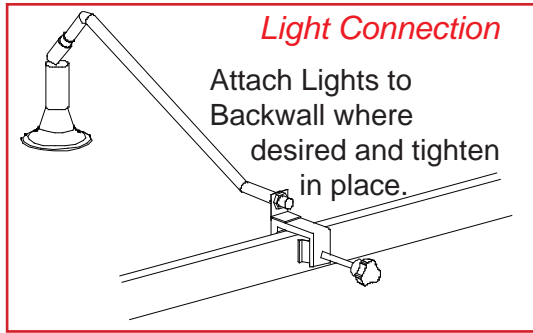

WHEN DISASSEMBLING ALUMINUM EXTRUSION, TIGHTEN ALL SETSCREWS AND LOCKS TO PREVENT LOSS DURING SHIPPING

Top View of each Level

Vertical Extrusion w/ A10 Clamps

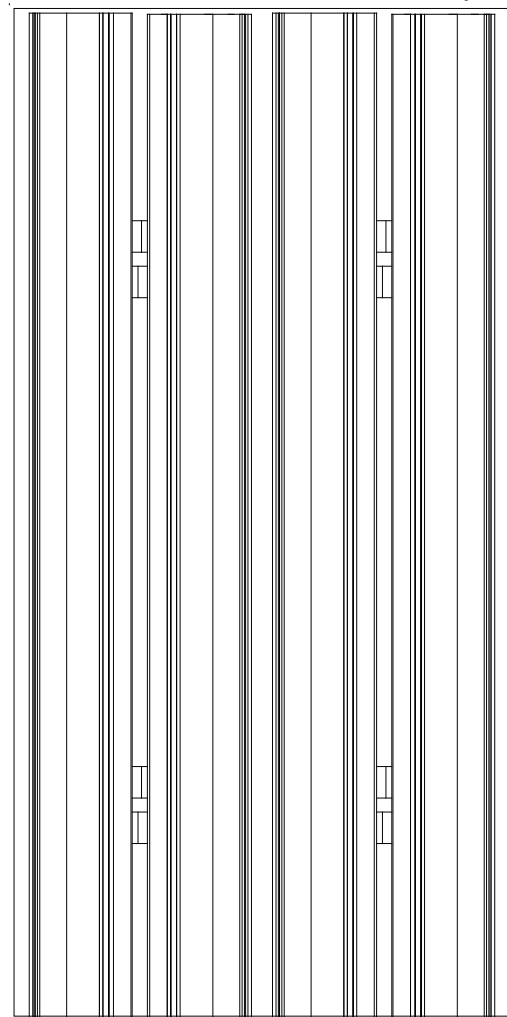

Level 1

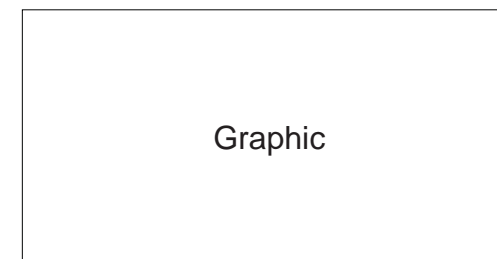
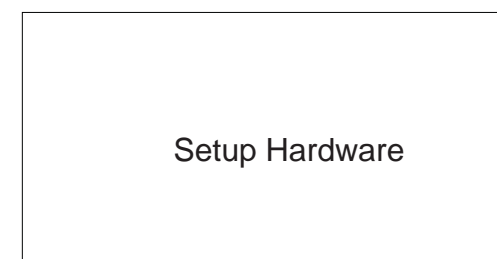

WHEN DISASSEMBLING ALUMINUM EXTRUSION, TIGHTEN ALL SETSCREWS AND LOCKS TO PREVENT LOSS DURING SHIPPING

Top View of each Level

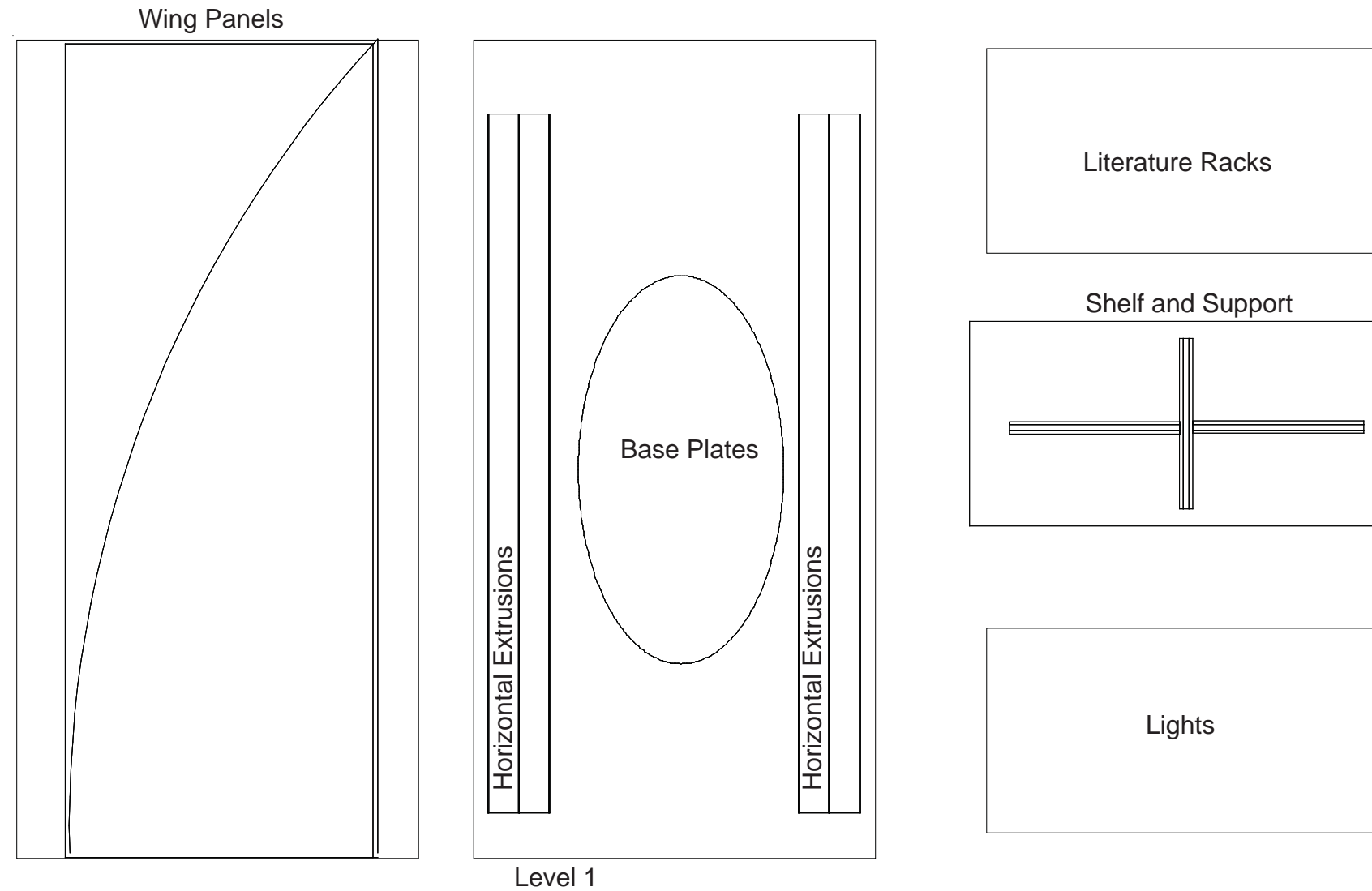

WHEN DISASSEMBLING ALUMINUM EXTRUSION, TIGHTEN ALL SETSCREWS AND LOCKS TO PREVENT LOSS DURING SHIPPING