

WHEN DISASSEMBLING ALUMINUM EXTRUSION, TIGHTEN ALL SETSCREWS AND LOCKS TO PREVENT LOSS DURING SHIPPING

## Using Your Setup Instructions

The Visionary Designs Setup Instructions are created specifically for your configuration. They are laid out sequentially, including an exploded view of the entire display, and then a logical series of detailed steps to assemble the main structure and components. We encourage you to study the instructions **before** attempting to assemble your exhibit.

Each page reminds you to tighten the setscrews after disassembling your exhibit to prevent loss of the locks and setscrews (see below in RED). This is **VERY IMPORTANT**.

## Cleaning and Packing Your Display

- 1) Use care when cleaning aluminum extrusion or acrylic inserts. Use only non-abrasive cleaners.
- 2) When cleaning laminate inserts or countertops, use mild cleansers and a soft material such as cotton.
- 3) Keep all display components away from extreme heat and long exposure to sunlight to avoid warping and fading.
- 4) Retain all packing material. It will make re-packing much easier and will reduce the likelihood of shipping damage.



**The Tool**

Most Visionary Designs exhibits can be assembled with the supplied Hex Key Tool. Occasionally, a flat head screwdriver may be required.



**Typical Connection**

Most horizontal extrusion connections have a patented expandable lock. This lock inserts into the groove of an opposing extrusion. Tightening the lock with the Hex Key Tool expands the lock and creates a strong positive connection.



**Typical Connection (cont'd)**

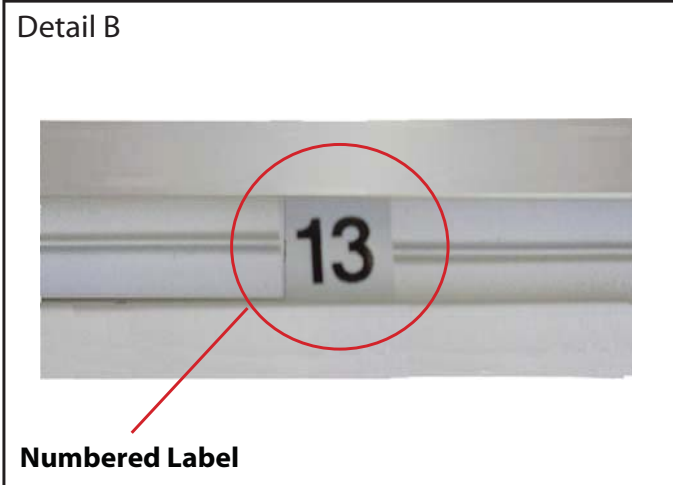

**Numbered Label**

Each extrusion contains a numbered label which corresponds with setup instructions. The label is located within a groove of the extrusion (when possible). With Visionary Designs the labels contain Black numbers unless otherwise specified.



**Horizontal Inline Connection** (remove only one setscrew)

Remove only (1) setscrew when disassembling. Replace setscrew in extrusion after assembling it. Before packing, replace setscrew in extrusion to avoid losing it.

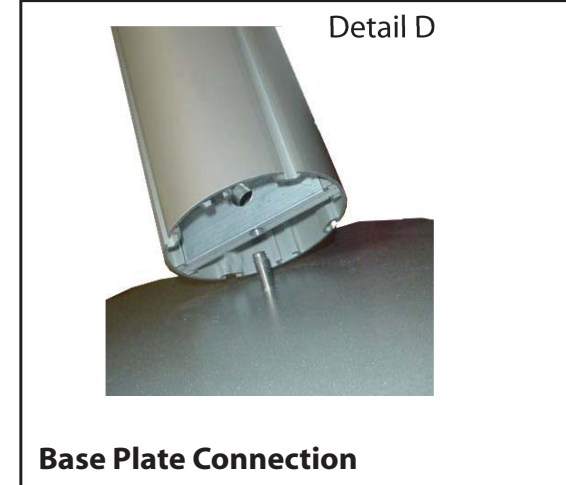

**Base Plate Connection**

Attach base plate to round or square vertical extrusion using the bolt provided. Be careful not to strip the threads.

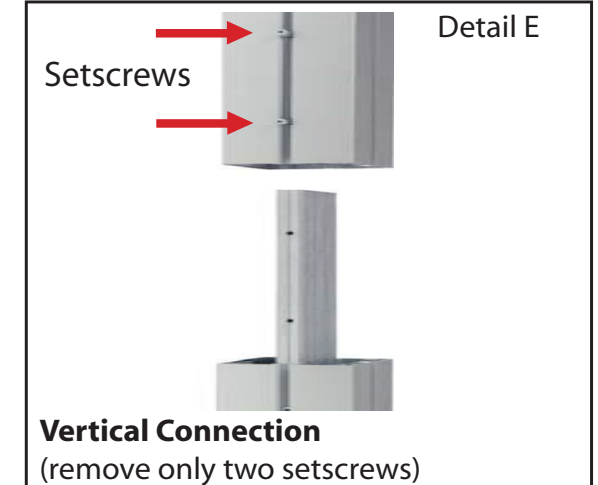

**Vertical Connection**  
(remove only two setscrews)

When vertical extrusions are packed in portable cases rather than crates or tubs, they must be broken down into smaller sections which then require assembly.

Remove only (2) setscrews when disassembling. Replace setscrews in extrusion after assembling it. Before packing, replace setscrews in extrusion to avoid losing them.

**WHEN DISASSEMBLING ALUMINUM EXTRUSION, TIGHTEN ALL SETSCREWS AND LOCKS TO PREVENT LOSS DURING SHIPPING**

Item	Qty.	Description
1	1	87”h Vertical extrusion
2	1	87”h Vertical extrusion
3	1	87”h Vertical extrusion
4	1	87”h Vertical extrusion
5	1	87”h Vertical extrusion
6	1	87”h Vertical extrusion
7	8	24”w Horizontal Extrusion
8	1	54”w Horizontal Extrusion
9	1	54”w Horizontal Extrusion
10	1	54”w 135° Horizontal Extrusion

Steps:

- 1) Attach horizontal bars between vertical extrusions, attaching frosted plaxi glass where indicated.  
 Note: *Horizontal bars [9 and 10] should stay assembled when disassemble unit.  
 A10 clips should stay assembled with vertical/ horizontal extrusions.*
- 2) Apply fabric graphic to assembled backwall.

**A10 Clamp Attachment**

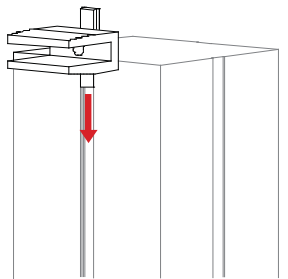

Slide connector on back of A10 clamp into groove of extrusion.

When desired location is found, tighten set screw to secure.

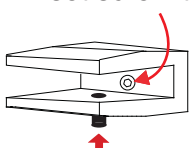

Tighten black plastic set screw to secure shelf in place.

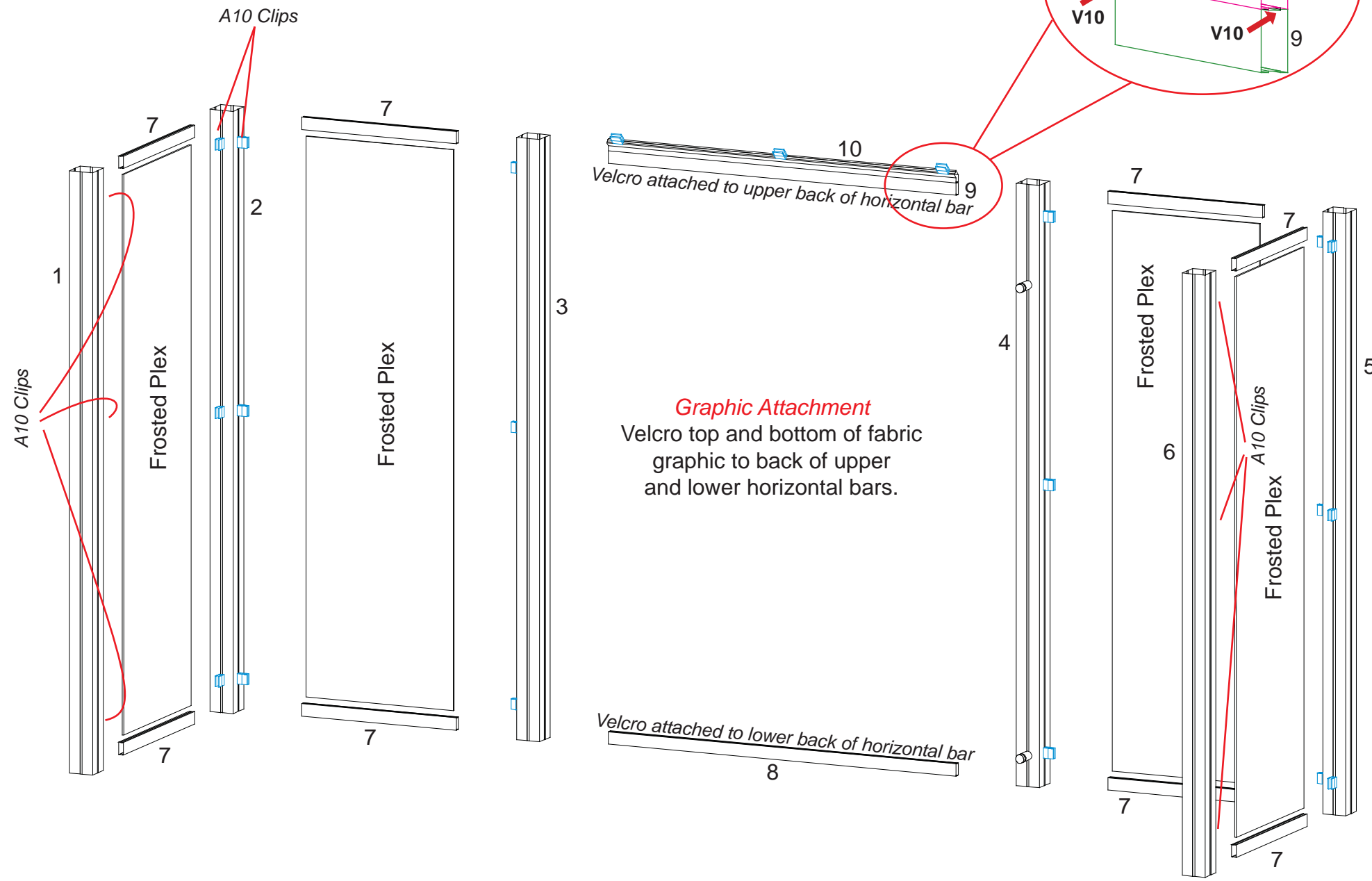

**V10 Pressure Screw**

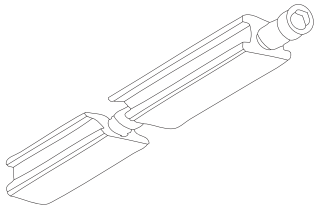

**Example of Pressure Screw Attachment**



Pressure Screw

**Tighten screw**



**If accidentally removed**  
Slide V10's in between both ends extrusions 9 and 10 then tighten to secure.

**WHEN DISASSEMBLING ALUMINUM EXTRUSION, TIGHTEN ALL SETSCREWS AND LOCKS TO PREVENT LOSS DURING SHIPPING**

Item	Qty.	Description
11	2	8" w Horizontal Extrusion
12	2	90° Connector
13	2	2.636" w Horizontal Extrusion
14	2	12" h Vertical Extrusion
15	2	48" w Horizontal Extrusion

- Steps:
- 1) Connect horizontal bars [15] between vertical extrusions [14], placing graphic infill between horizontals.
  - 2) Assemble support arms together [11 to 12 to 13].
  - 3) Connect support arms to both sides of assembled graphic frame.
  - 4) Attach assembled frame to backwall where indicated.
  - 5) Attach graphic with wood frame to backwall where indicated using standoffs as shown in illustration.

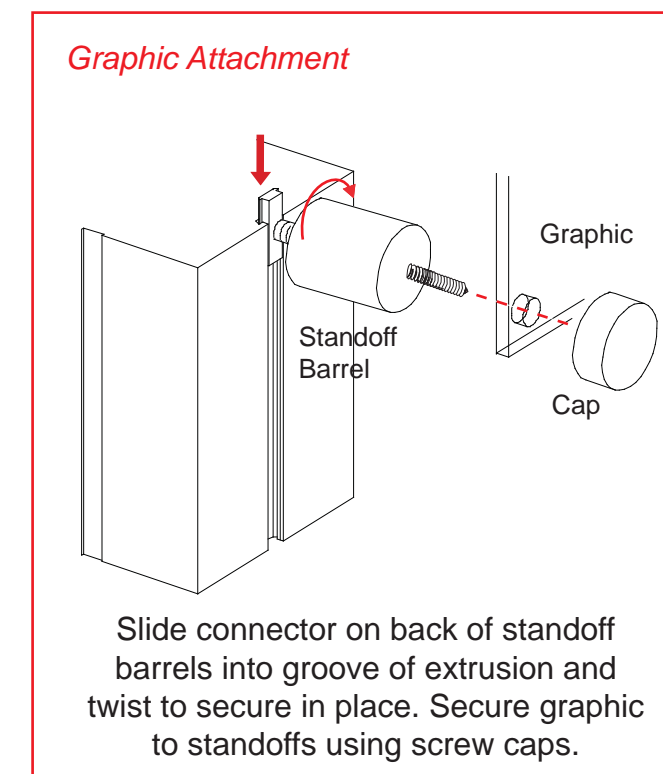
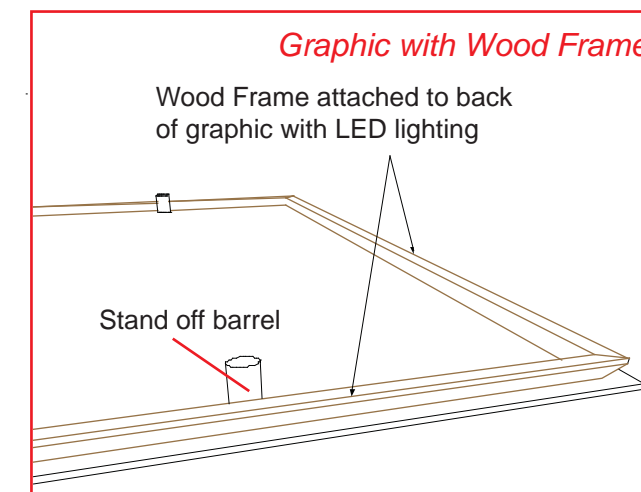
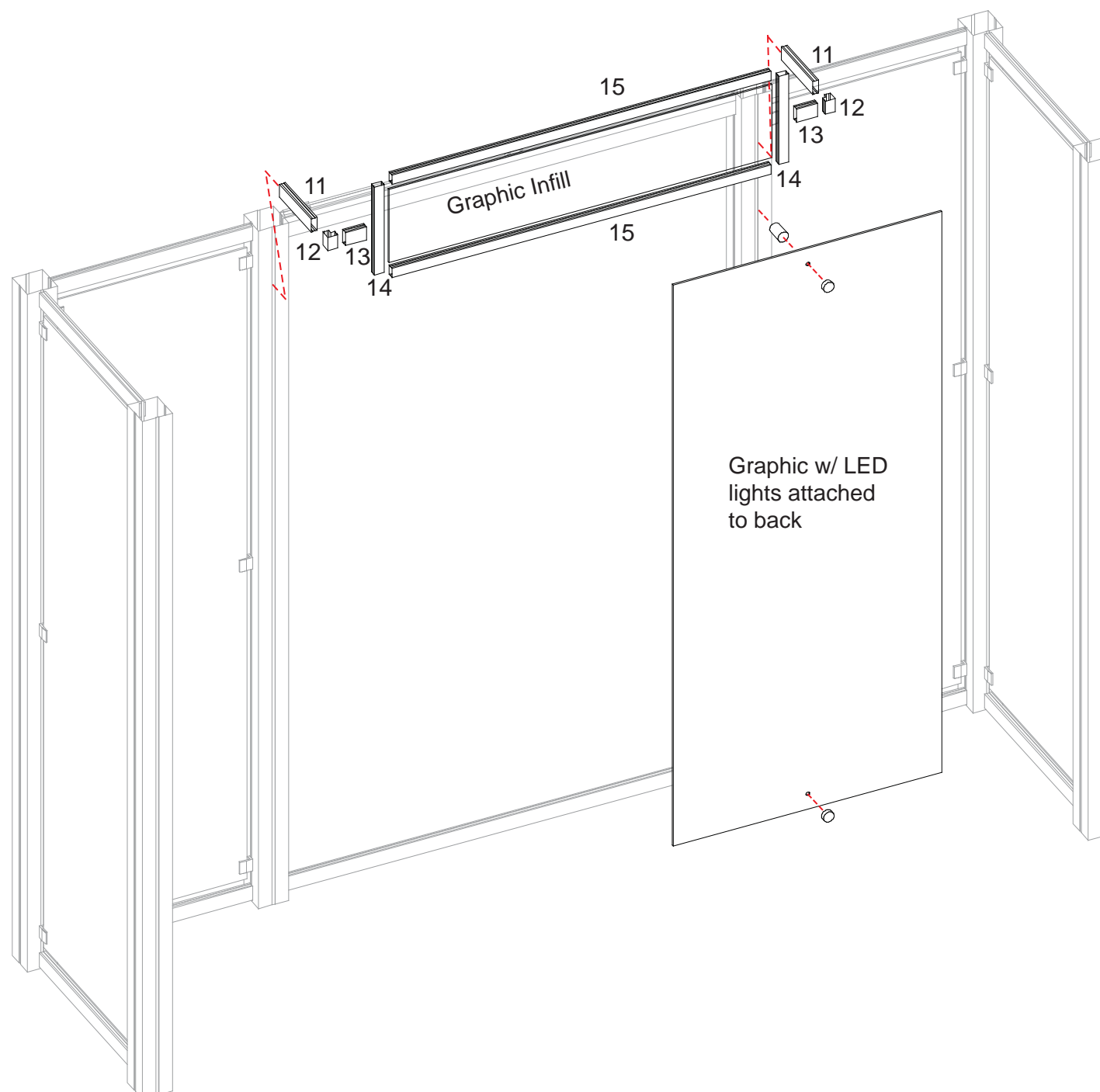
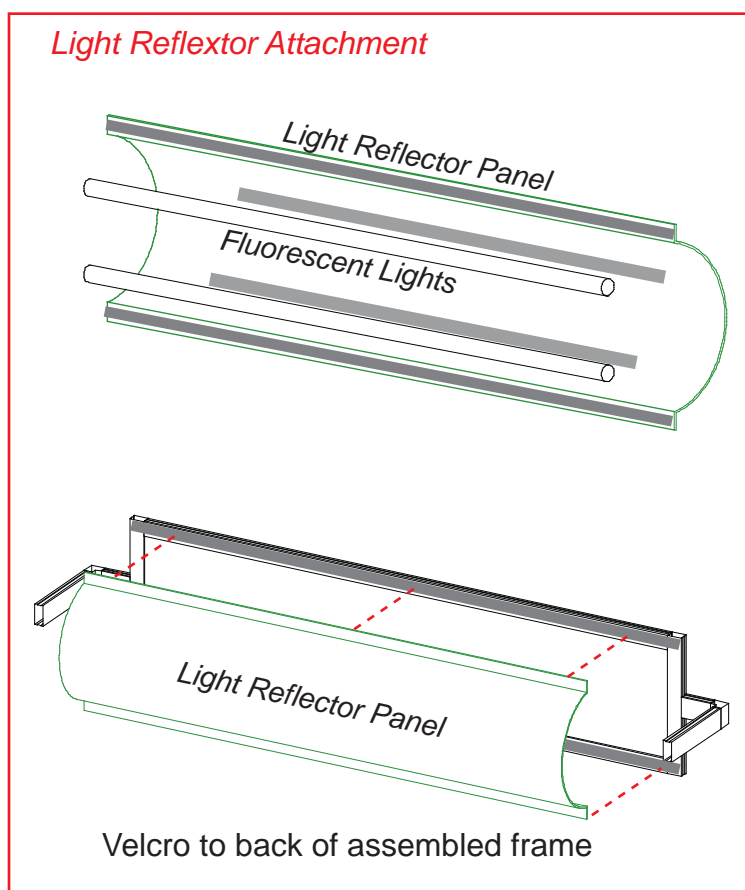

**WHEN DISASSEMBLING ALUMINUM EXTRUSION, TIGHTEN ALL SETSCREWS AND LOCKS TO PREVENT LOSS DURING SHIPPING**

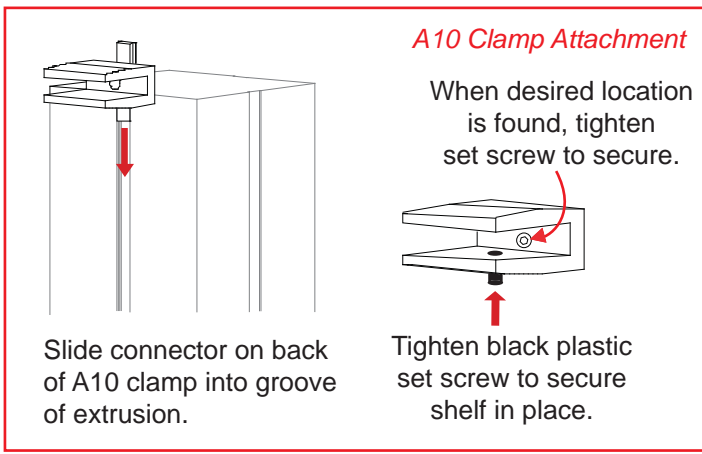
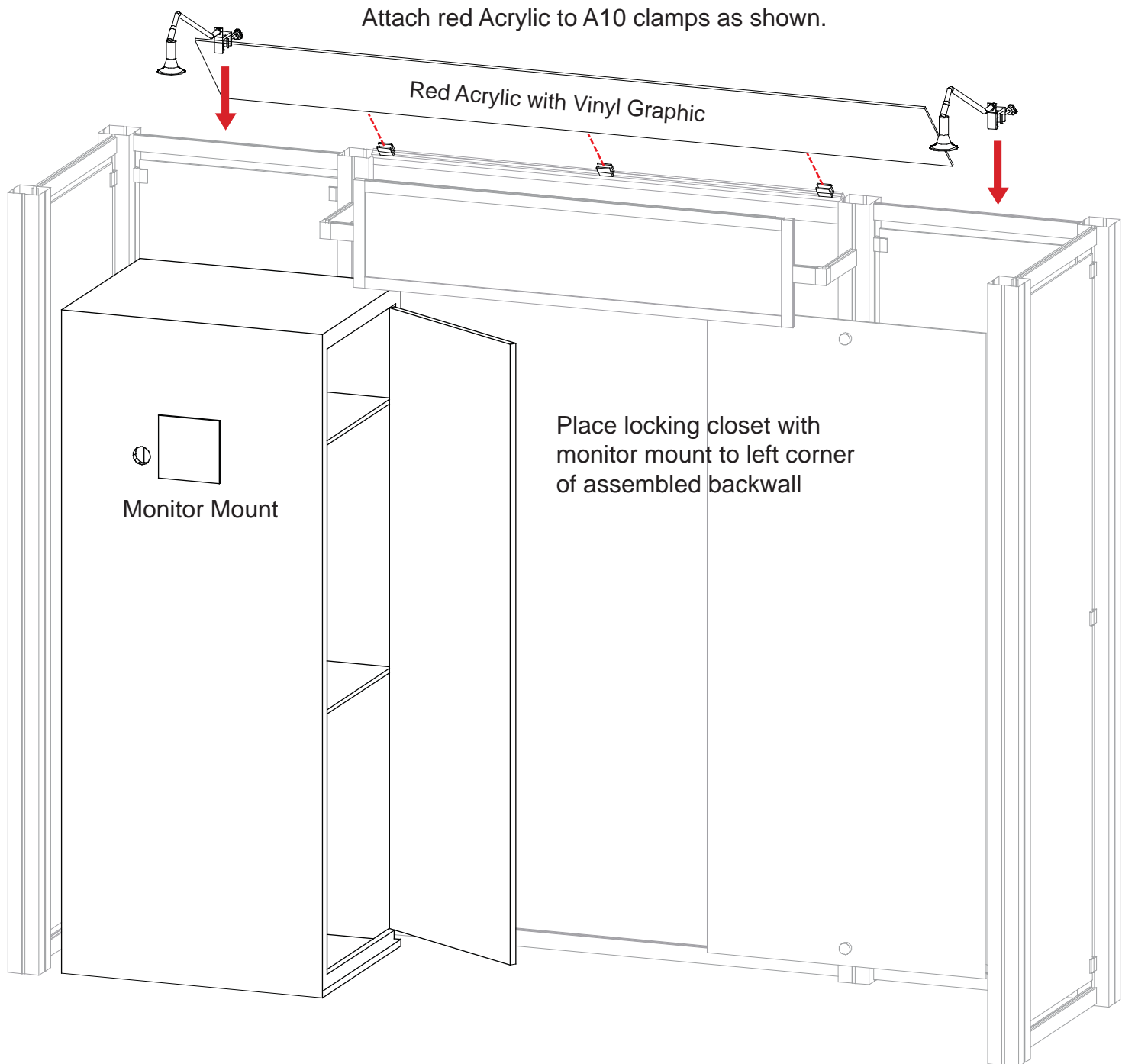

**WHEN DISASSEMBLING ALUMINUM EXTRUSION, TIGHTEN ALL SETSCREWS AND LOCKS TO PREVENT LOSS DURING SHIPPING**

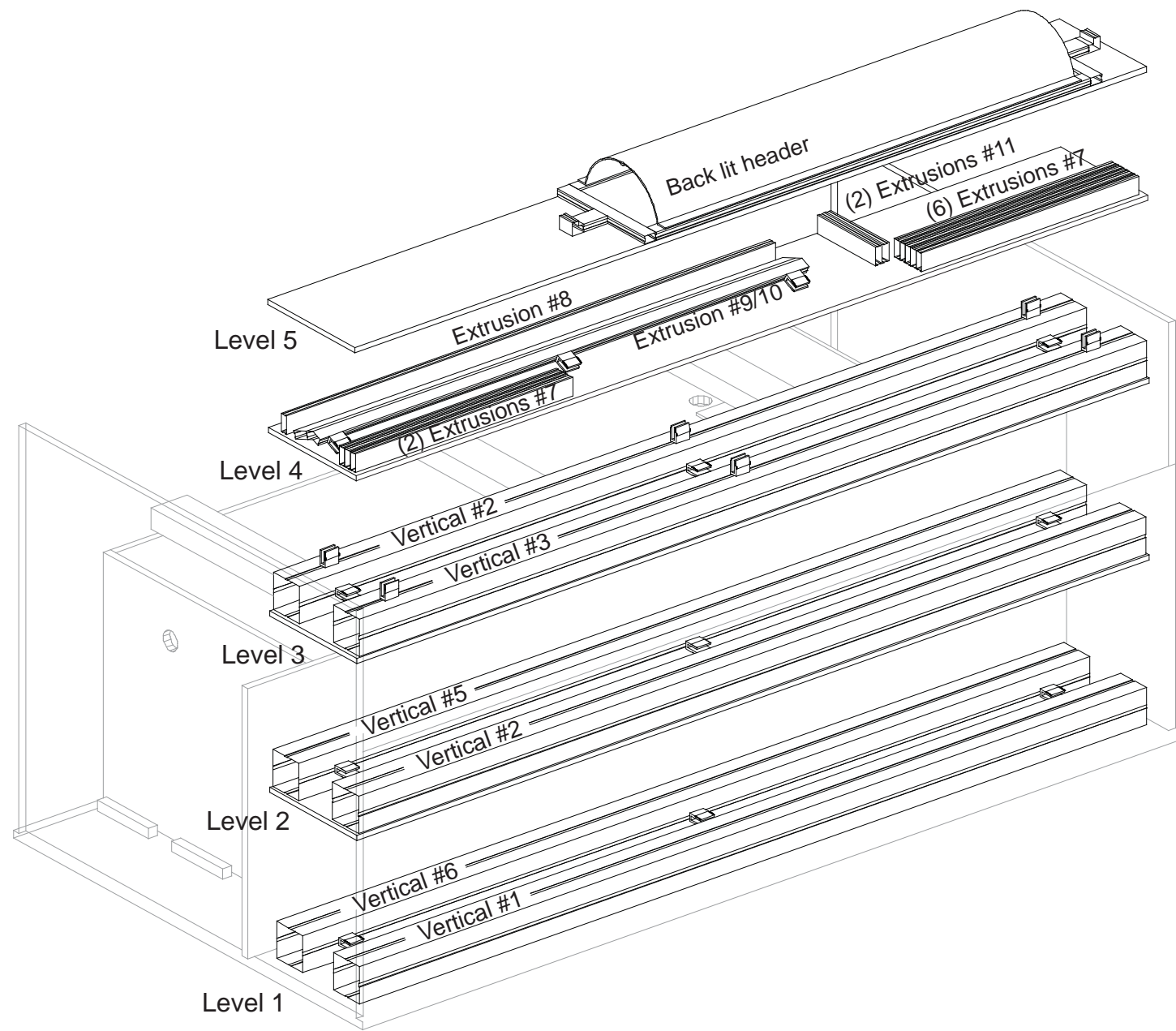

WHEN DISASSEMBLING ALUMINUM EXTRUSION, TIGHTEN ALL SETSCREWS AND LOCKS TO PREVENT LOSS DURING SHIPPING

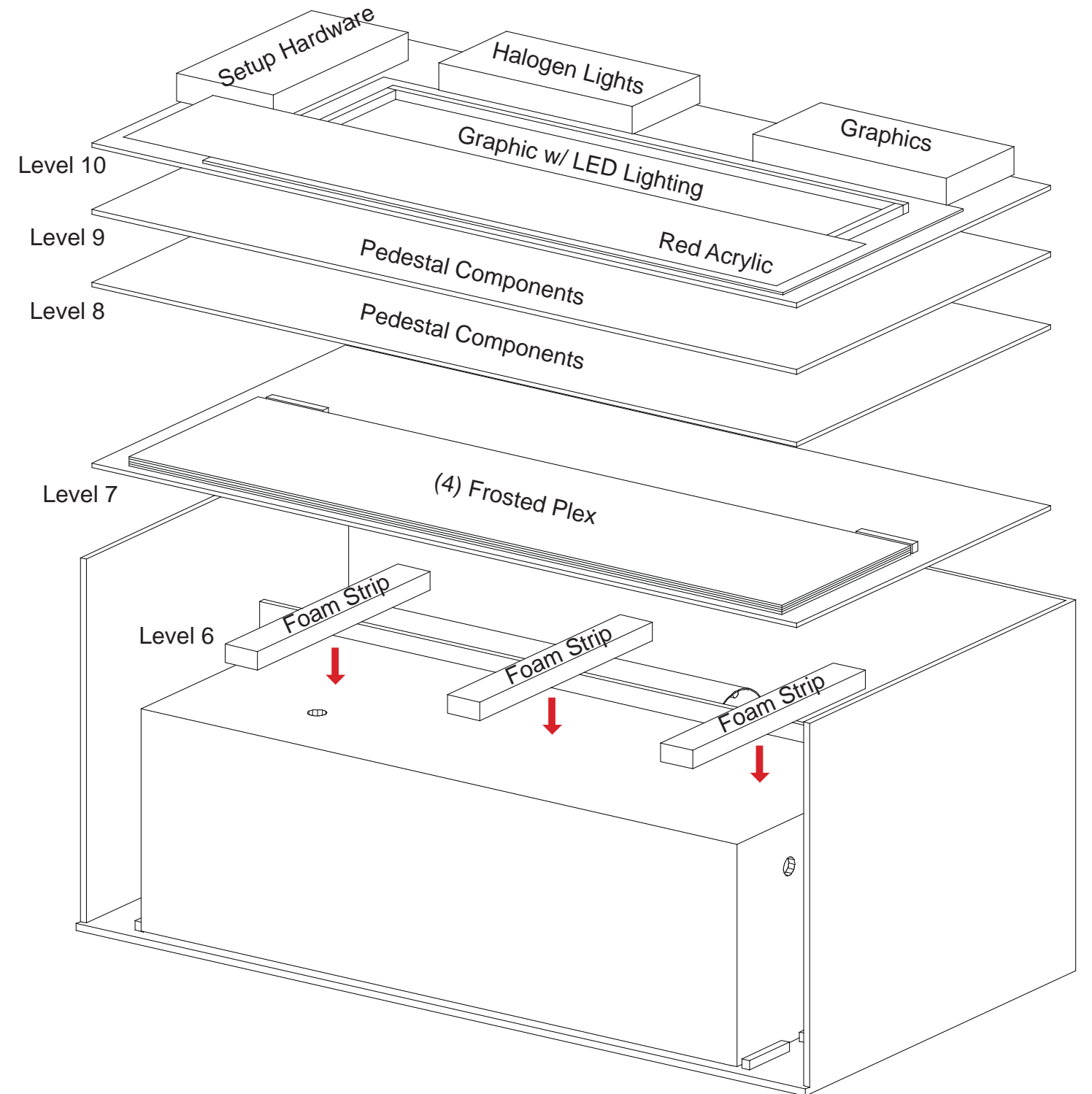

WHEN DISASSEMBLING ALUMINUM EXTRUSION, TIGHTEN ALL SETSCREWS AND LOCKS TO PREVENT LOSS DURING SHIPPING