

WHEN DISASSEMBLING ALUMINUM EXTRUSION, TIGHTEN ALL SETSCREWS AND LOCKS TO PREVENT LOSS DURING SHIPPING

visionary™ DESIGNS

Using Your Setup Instructions

The Visionary Designs Setup Instructions are created specifically for your configuration. They are laid out sequentially, including an exploded view of the entire display, and then a logical series of detailed steps to assemble the main structure and components. We encourage you to study the instructions **before** attempting to assemble your exhibit.

Each page reminds you to tighten the setscrews after disassembling your exhibit to prevent loss of the locks and setscrews (see below in RED). This is **VERY IMPORTANT**.

Cleaning and Packing Your Display

- 1) Use care when cleaning aluminum extrusion or acrylic inserts. Use only non-abrasive cleaners.
- 2) When cleaning laminate inserts or countertops, use mild cleansers and a soft material such as cotton.
- 3) Keep all display components away from extreme heat and long exposure to sunlight to avoid warping and fading.
- 4) Retain all packing material. It will make re-packing much easier and will reduce the likelihood of shipping damage.



The Tool

Most Visionary Designs exhibits can be assembled with the supplied Hex Key Tool. Occasionally, a flat head screwdriver may be required.



Detail A

Typical Connection



Typical Connection (cont'd)

Most horizontal extrusion connections have a patented expandable lock. This lock inserts into the groove of an opposing extrusion. Tightening the lock with the Hex Key Tool expands the lock and creates a strong positive connection.

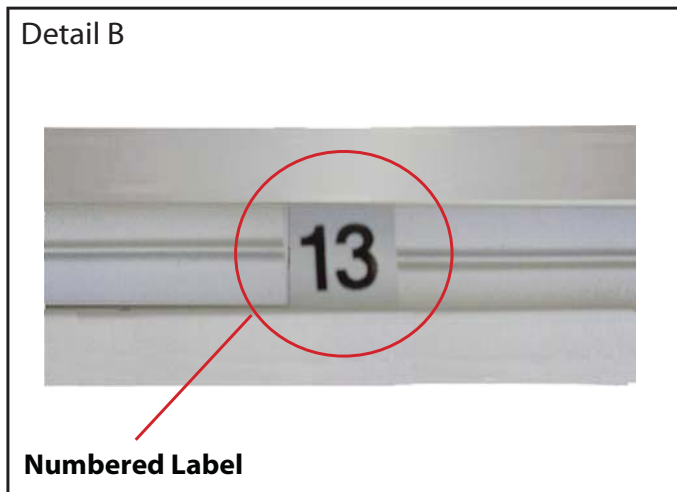

Detail B

Numbered Label

Each extrusion contains a numbered label which corresponds with setup instructions. The label is located within a groove of the extrusion (when possible). With Visionary Designs the labels contain Black numbers unless otherwise specified.



Detail C

Horizontal Inline Connection (remove only one setscrew)

Remove only (1) setscrew when disassembling. Replace setscrew in extrusion after assembling it. Before packing, replace setscrew in extrusion to avoid losing it.

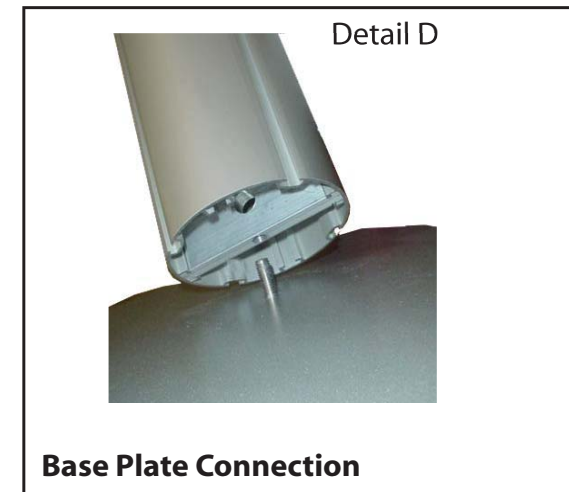

Detail D

Base Plate Connection

Attach base plate to round or square vertical extrusion using the bolt provided. Be careful not to strip the threads.

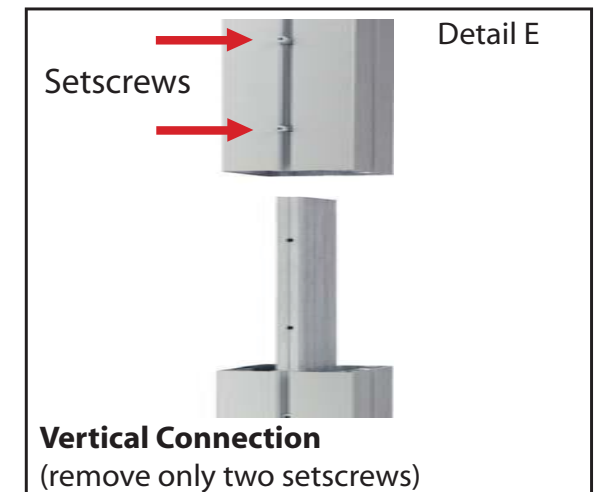

Detail E

Vertical Connection
(remove only two setscrews)

When vertical extrusions are packed in portable cases rather than crates or tubs, they must be broken down into smaller sections which then require assembly.

Remove only (2) setscrews when disassembling. Replace setscrews in extrusion after assembling it. Before packing, replace setscrews in extrusion to avoid losing them.

WHEN DISASSEMBLING ALUMINUM EXTRUSION, TIGHTEN ALL SETSCREWS AND LOCKS TO PREVENT LOSS DURING SHIPPING

866.652.2100

Item	Qty.	Description
1	3	Oval Base Plate with 1 Center Hole
1a	2	Oval Base Plate with 1 Rear Hole
2	5	42" h Lower Vertical Extrusion
3	3	42" h Upper Vertical Extrusion
3a	2	42" h Upper Vertical Extrusion w/ Canopy Attachment
4a/4b	1/1	36.128" Curved Horizontal Extrusion
5a/5b	1/1	36.128" Curved Horizontal Extrusion
6a/6b	1/1	42" Horizontal Extrusion
7a/7b	1/1	42" Horizontal Extrusion
8	1	36.128" Curved Horizontal Extrusion
9	1	36.128" Curved Horizontal Extrusion
10	1	36.128" Curved Horizontal Extrusion
11	1	36.128" Curved Horizontal Extrusion

- Steps:
- 1) Connect lower vertical extrusions [2] to base plates [1].
 - 2) Connect upper horizontal extrusions [3 and 3a] to lower vertical extrusions [2].
 - 3) Connect horizontal extrusions [4a to 4b, 5a to 5b, 6a to 6b and 7a to 7b] together.
 - 4) Attach assembled horizontal extrusions [6a/6b and 7a/7b] and horizontal extrusions [4, 5, 8, 9 , 10 and 11] between assembled vertical extrusions [2/3 and 2/3a].
 - 5) Attach lights to upper horizontal extrusions as indicated.

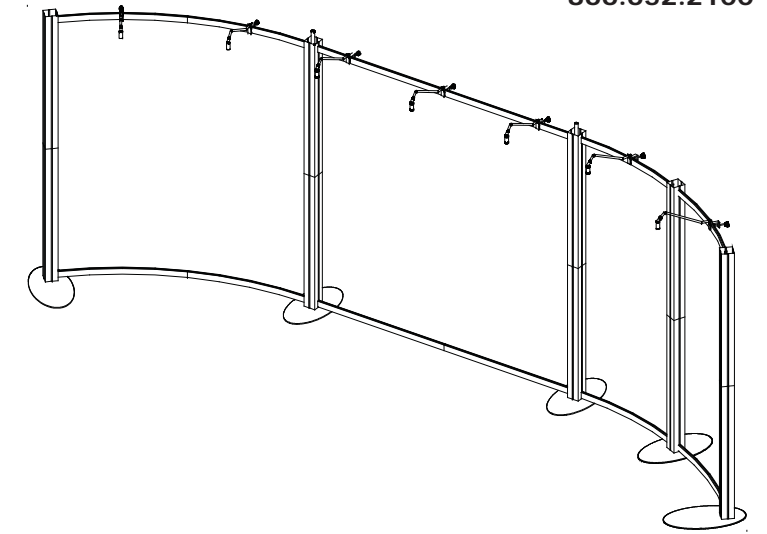

Velcro must be on under side of upper horizontals

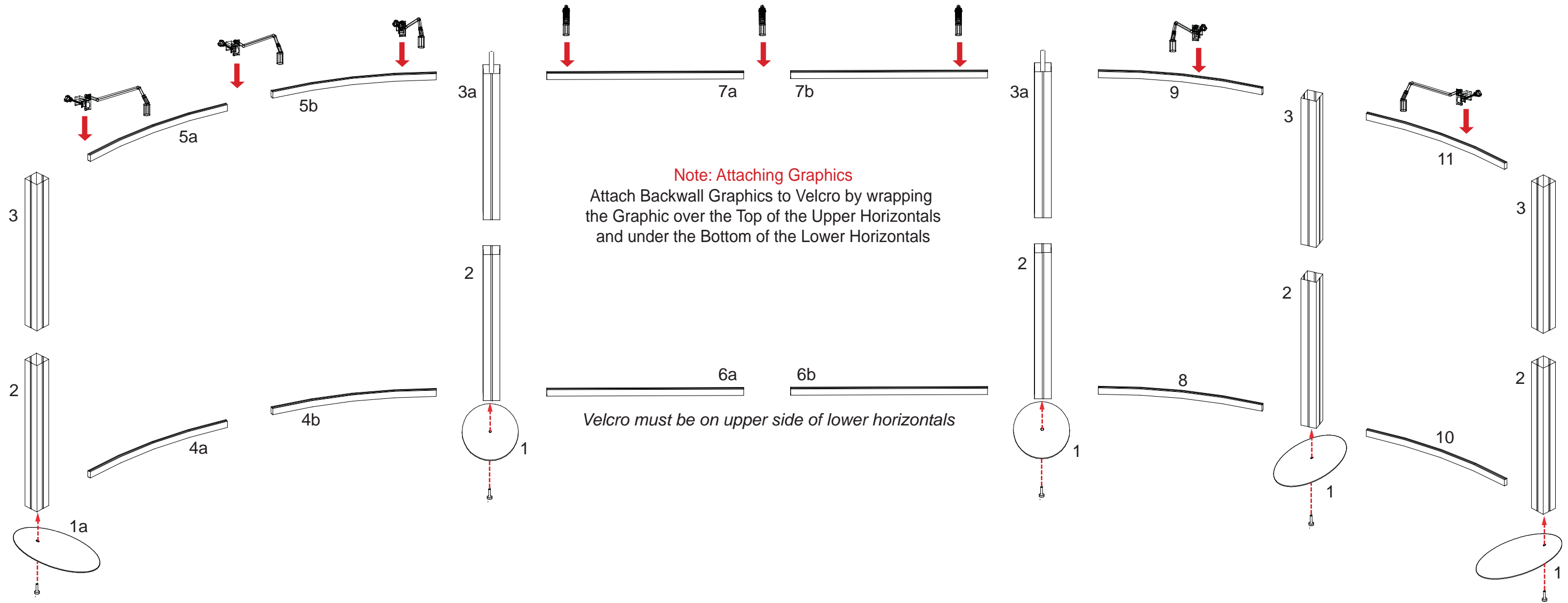

WHEN DISASSEMBLING ALUMINUM EXTRUSION, TIGHTEN ALL SETSCREWS AND LOCKS TO PREVENT LOSS DURING SHIPPING



- Steps:
- 1) Connect canopy pieces together as shown.
 - 2) Apply pillow case graphic to assembled canopy

Using Your Setup Instructions

The Aero Overhead Sign Setup Instructions are created specifically for your configuration. They include an exploded view of the frame which is sequentially numbered. We encourage you to study the instructions before attempting to assemble your exhibit.

Connections are kept very simple: no tools. Everything assembles with push-button connectors and pre-connected horizontal sections.

Cleaning and Packing Your Display

- 1) Use care when cleaning aluminum extrusion or acrylic inserts. Use only non-abrasive cleaners.
- 2) Retain all packing material. It will make re-packing much easier and will reduce the likelihood of shipping damage.

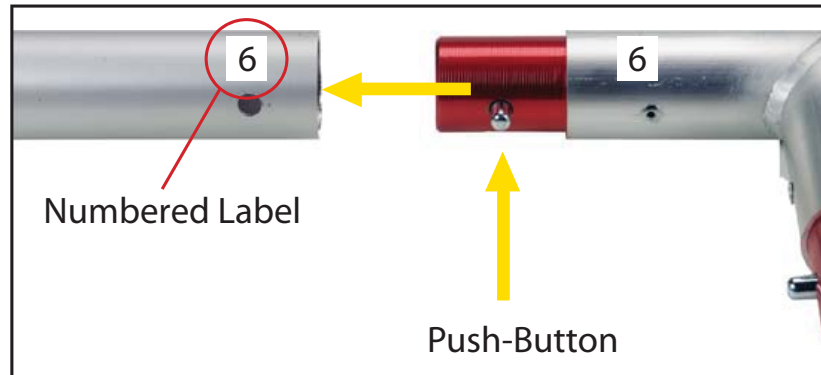
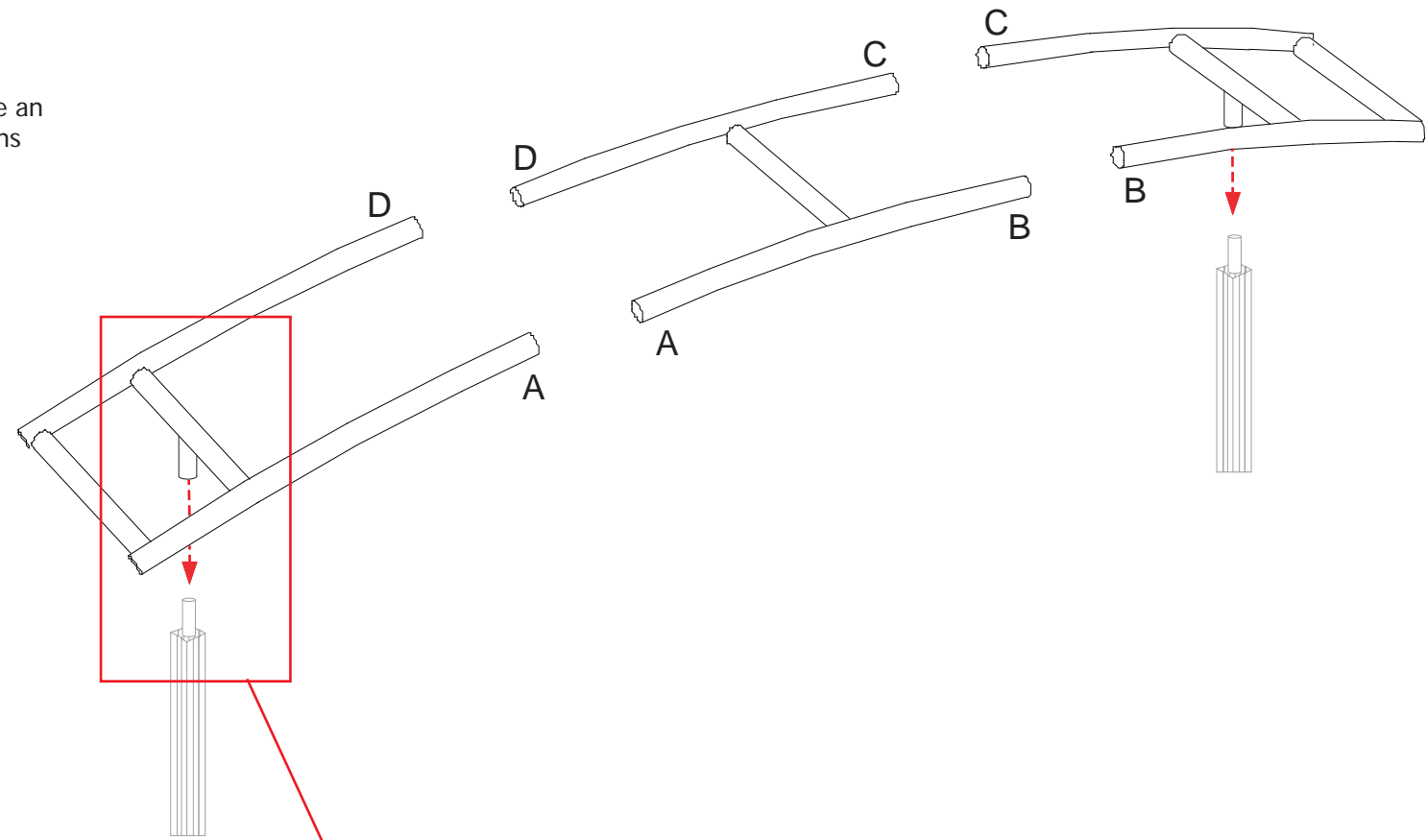

Connections are made by holding the button down and sliding the red tube into opposing tube until the connection is made. To disassemble push button and pull or twist extrusions apart.

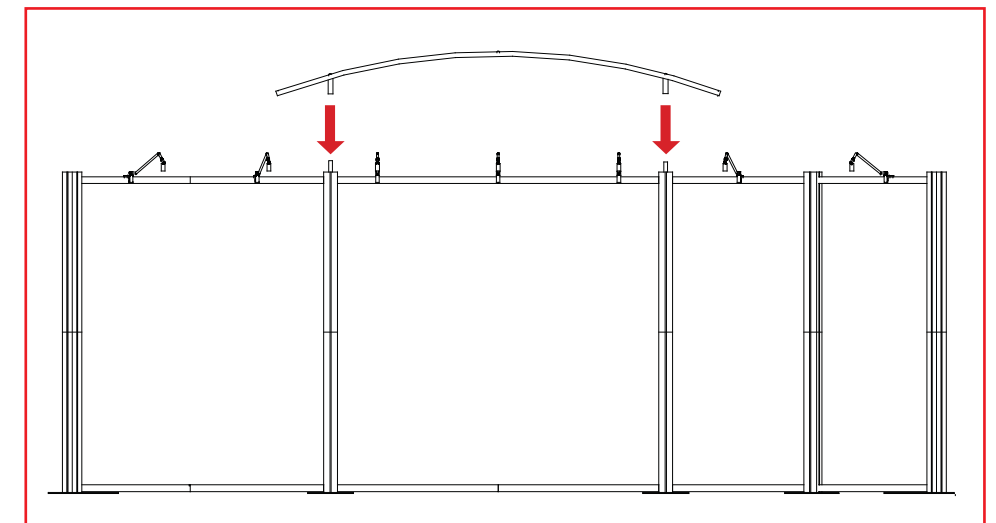
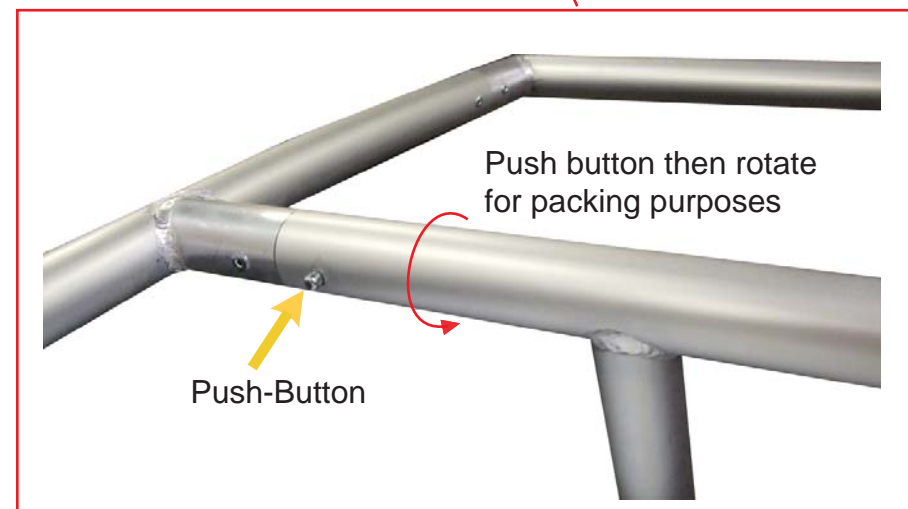
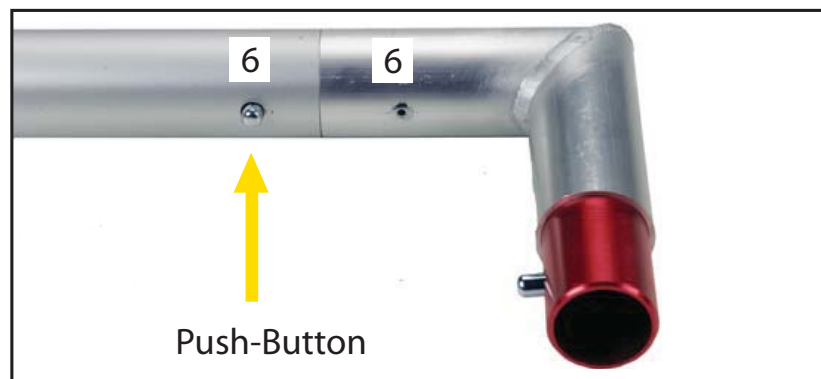

WHEN DISASSEMBLING ALUMINUM EXTRUSION, TIGHTEN ALL SETSCREWS AND LOCKS TO PREVENT LOSS DURING SHIPPING

866.652.2100

Item	Qty.	Description
12	1	37.50" Vertical Extrusion
13	1	37.50" Vertical Extrusion
14	1	37.50" Vertical Extrusion
14a	1	Door Stop
15	1	37.50" Vertical Extrusion
16	2	Horizontal Extrusion w/ Lip
17	2	Horizontal Extrusion
18	4	Curve Horizontal Extrusion

Steps

- 1) Connect lower horizontal extrusions [16 and 18] between vertical extrusions [12, 13, 14 and 15] as shown.
- 2) Attach door stop [14a] to lower curve extrusion [18] then attach door between extrusions [13 and 14a].
- 3) Place insert panels where indicated.
- 4) Attach upper horizontal extrusions [17 and 18] between vertical extrusions [12, 13, 14 and 15] and atop inserts and door.
- 5) Place shelf atop lip of extrusions [16].
- 6) Set counter top on assembled pedestal.

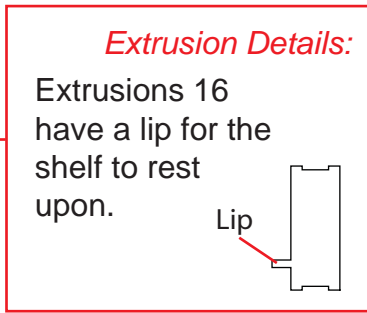
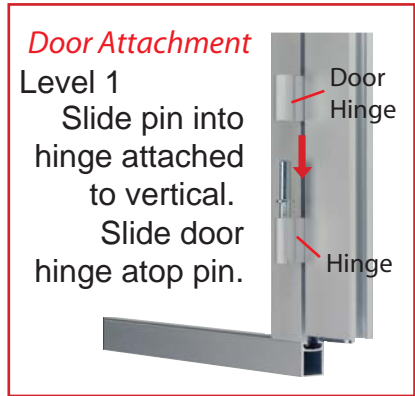
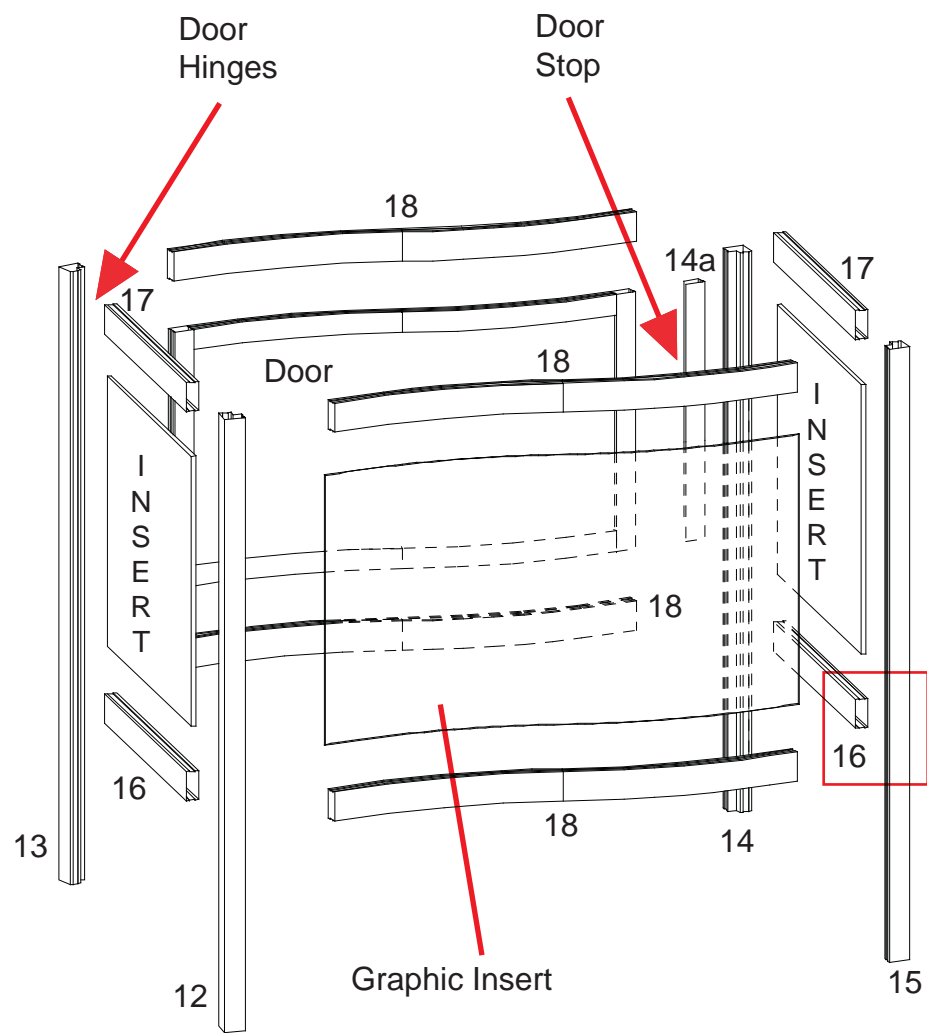
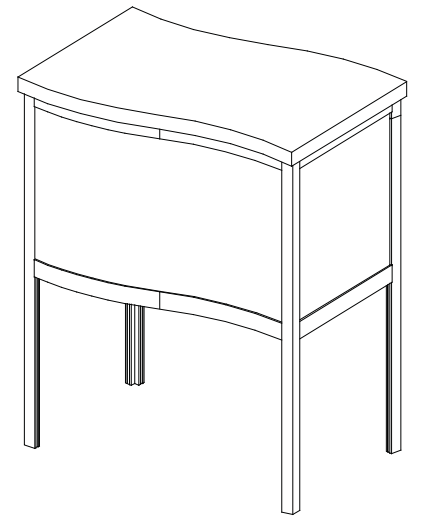

Level 2

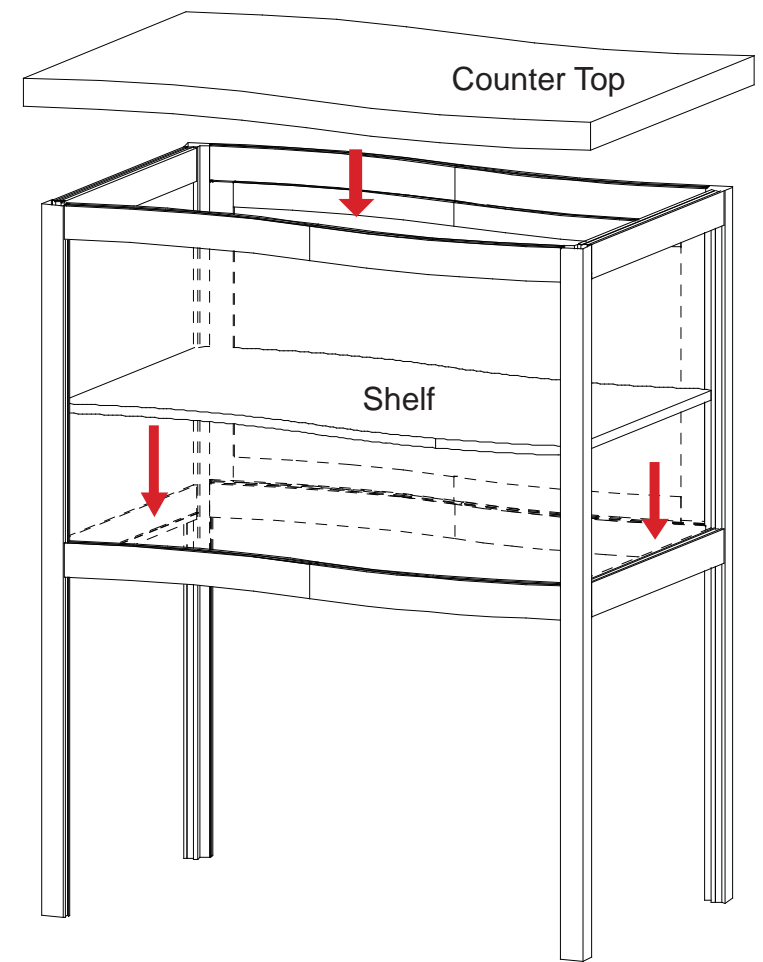

WHEN DISASSEMBLING ALUMINUM EXTRUSION, TIGHTEN ALL SETSCREWS AND LOCKS TO PREVENT LOSS DURING SHIPPING

Top View of each Level

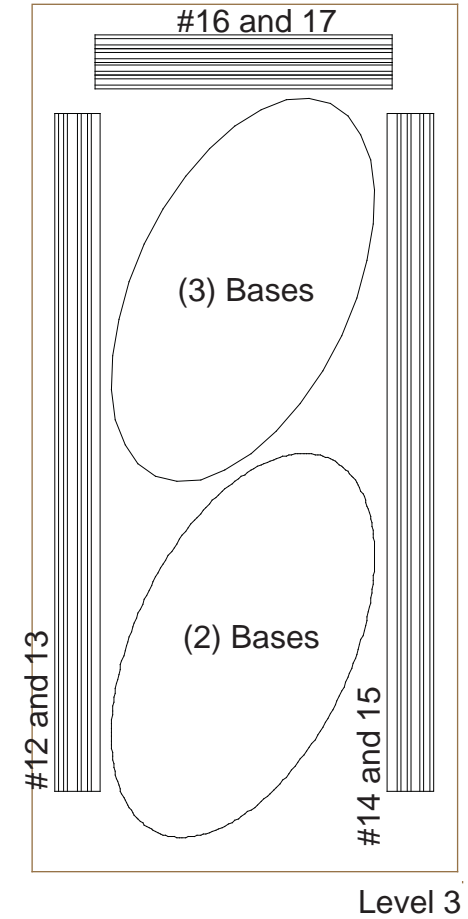
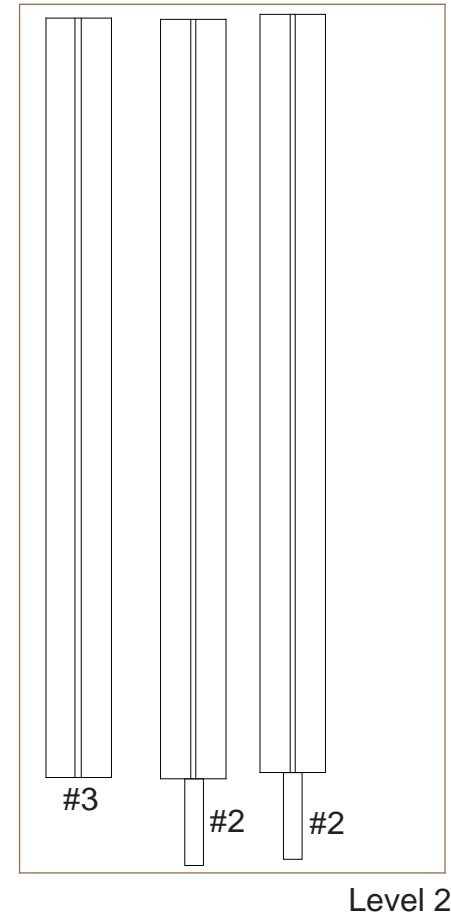
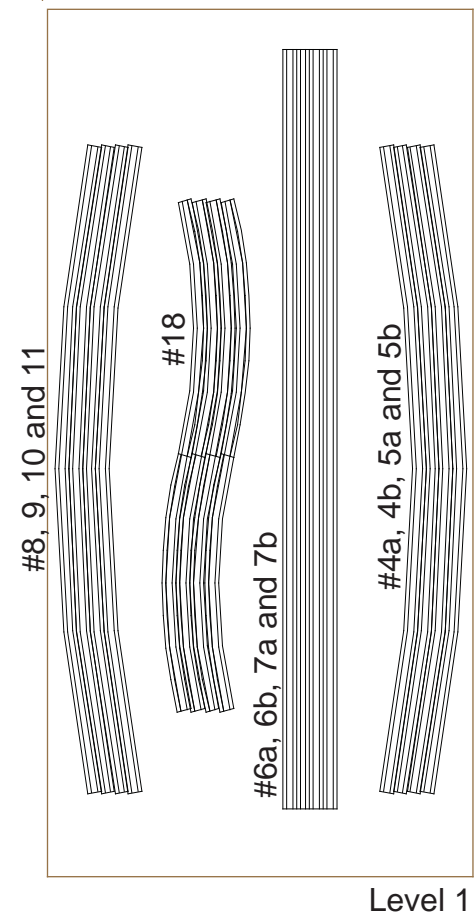

WHEN DISASSEMBLING ALUMINUM EXTRUSION, TIGHTEN ALL SETSCREWS AND LOCKS TO PREVENT LOSS DURING SHIPPING

Top View of each Level

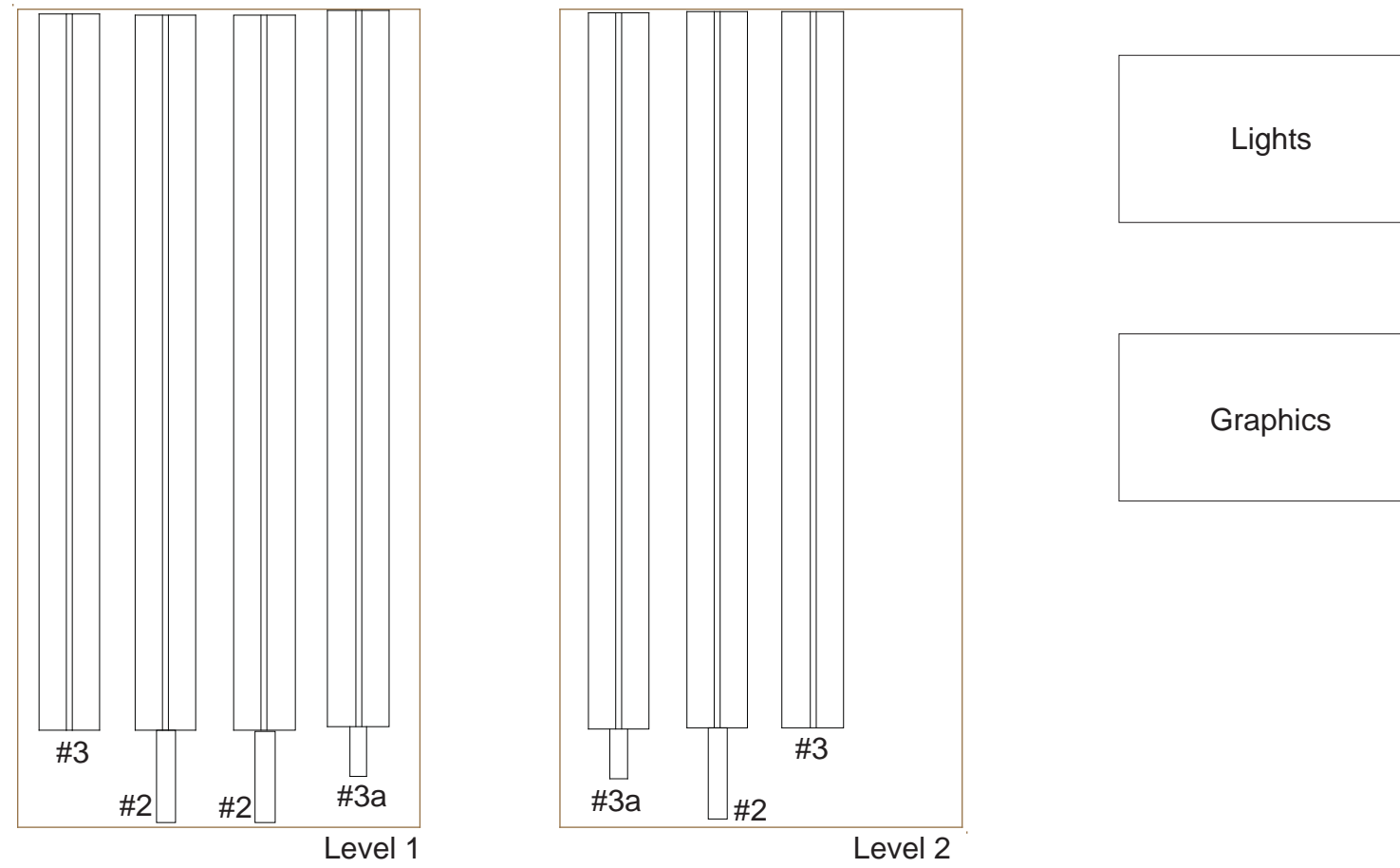

WHEN DISASSEMBLING ALUMINUM EXTRUSION, TIGHTEN ALL SETSCREWS AND LOCKS TO PREVENT LOSS DURING SHIPPING

Top View of each Level

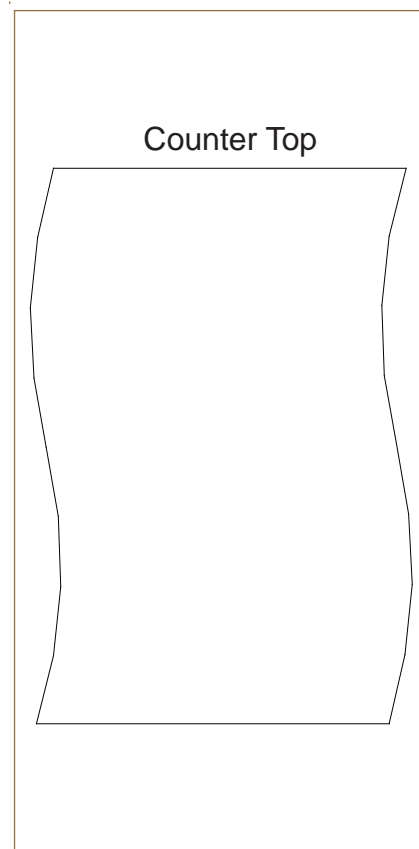

Level 1

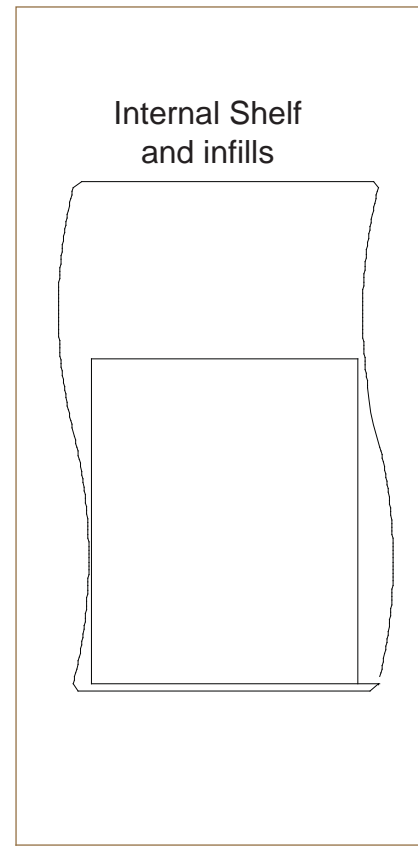

Level 2

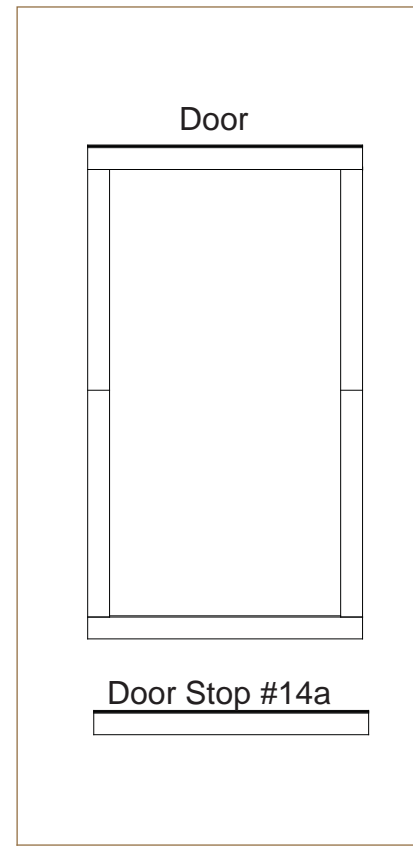

Level 3

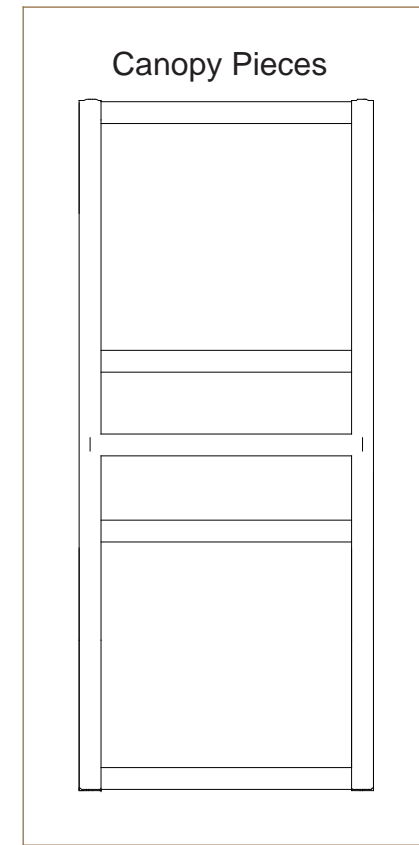

Level 4

WHEN DISASSEMBLING ALUMINUM EXTRUSION, TIGHTEN ALL SETSCREWS AND LOCKS TO PREVENT LOSS DURING SHIPPING