

Perfect 10 Hybrid Displays

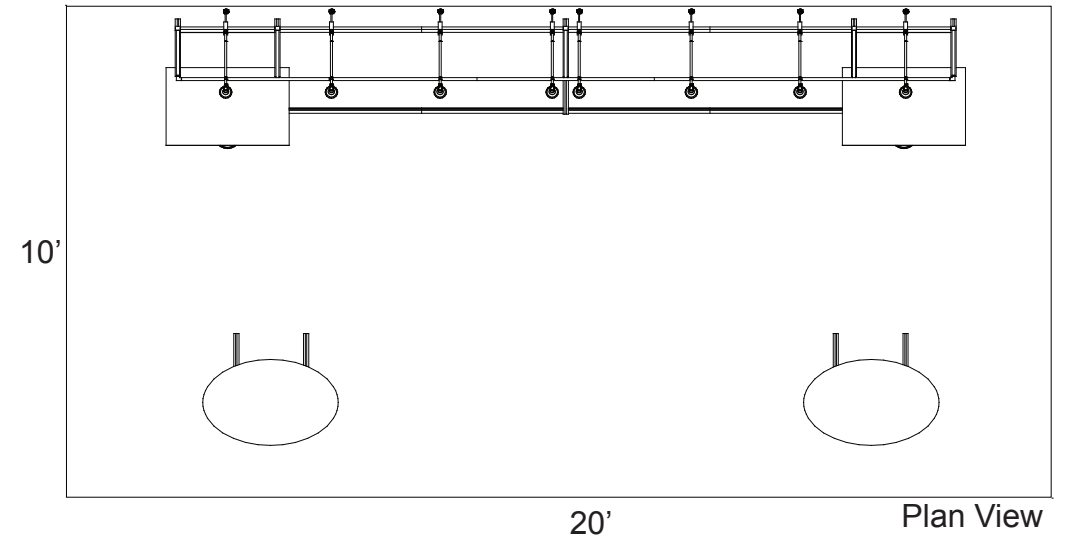
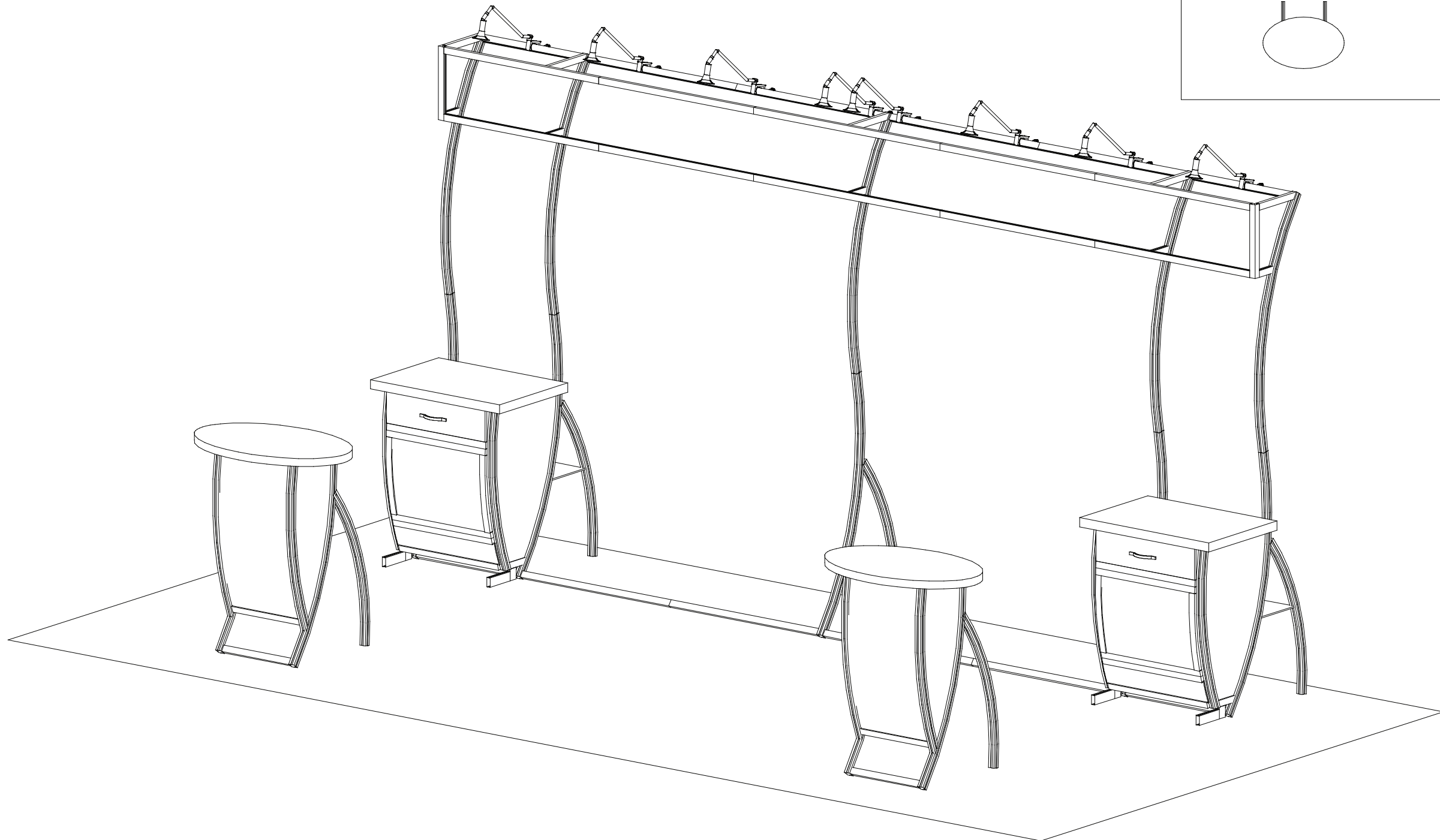

WHEN DISASSEMBLING TIGHTEN ALL KNOBS TO PREVENT LOSS DURING SHIPPING

866.652.2100

Part Number	Description
1	Left Leg Assembly
2	Leg Assembly
3	Upper Curved Vertical
4	Upper Curved Vertical
5	23" w Horizontal
6	Storage Side Assembly
7	Storage Side Assembly
6a/7a	Support Extrusions
8	23" w Horizontal
9	23" w Horizontal
10	23" w Horizontal

Steps:

NOTE: Can be assembled either face down on floor then lifted upright or upright as shown in drawings.

- 1) Connect lower horizontal [5] between leg assemblies [1 and 2].
- 2) Attach upper verticals to lower verticals, then connect upper horizontal [5] between verticals.
- 3) Attach storage side assemblies with infills to front of legs [1 and 2].
- 4) Attach support pieces [6a and 7a] where indicated, then set floor in place.
- 5) Connect horizontals [8, 9 and 10] between side assemblies, placing infill and attach door between horizontals as shown.

NOTE: Make sure the lock is flush with extrusion before tightening. If lock will not fully engage, gently rock lock and extrusion while turning knob until lock fully opens.



Step stool may be required for assembly.

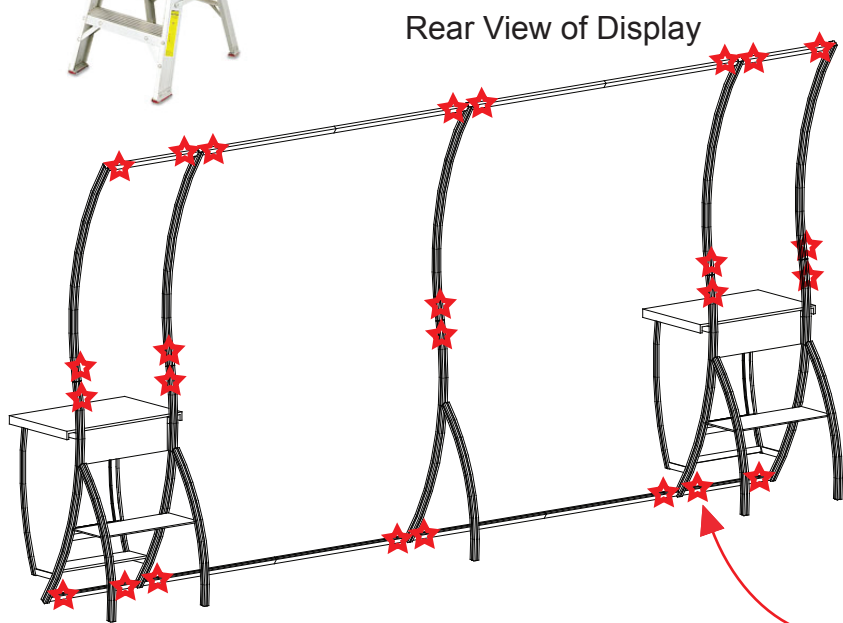

Rear View of Display

STAR indicates location of knobs on BACKSIDE of unit.

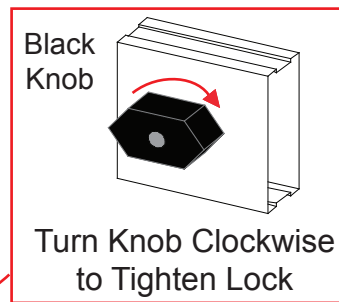

Turn Knob Clockwise to Tighten Lock

Side Assembly must stay assembled when shipping

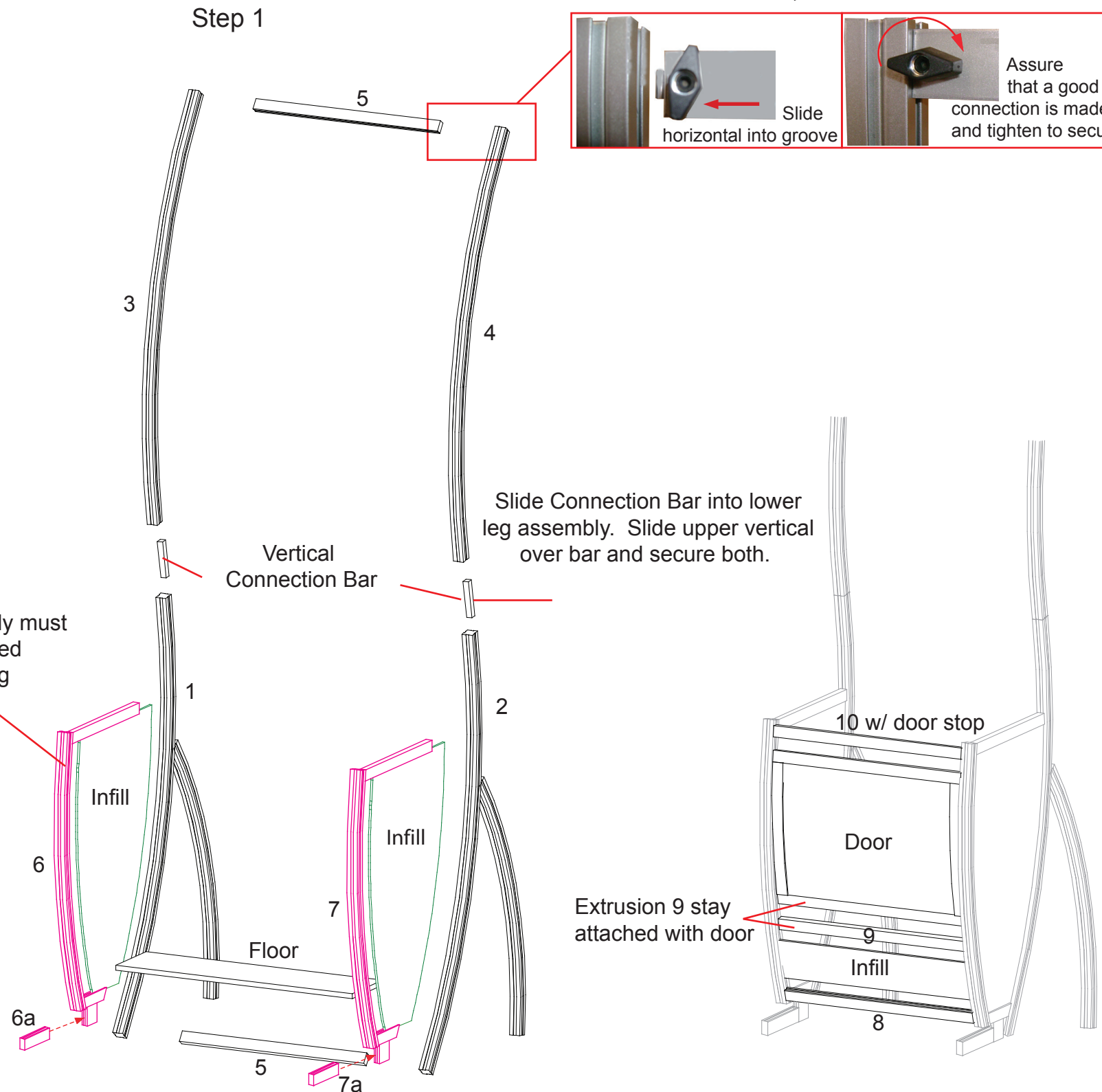

NOTE: When assembling horizontals they should be placed approximately one inch from TOP and BOTTOM.

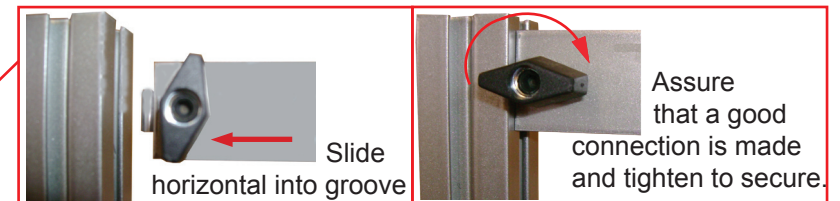

Slide horizontal into groove

Assure that a good connection is made and tighten to secure.

Slide Connection Bar into lower leg assembly. Slide upper vertical over bar and secure both.

Extrusion 9 stay attached with door

WHEN DISASSEMBLING TIGHTEN ALL KNOBS TO PREVENT LOSS DURING SHIPPING

866.652.2100

Part Number	Description
11	Leg Assembly
12	Upper Curved Vertical
13	69" w Horizontal w/ Hinge Facing UP
14	69" w Horizontal w/ Hinge Facing DOWN

Steps:

NOTE: Can be assembled either face down on floor then lifted upright or upright as shown in drawings.

- 1) Connect lower horizontal [13] between leg assemblies [2 and 11].
- 2) Attach upper verticals to lower verticals, then connect upper horizontal [14] between verticals.

NOTE: Make sure the lock is flush with extrusion before tightening. If lock will not fully engage, gently rock lock and extrusion while turning knob until lock fully opens.

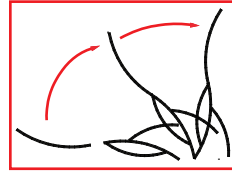

Step 2

NOTE: When assembling horizontals they should be placed approximately one inch from TOP and BOTTOM.

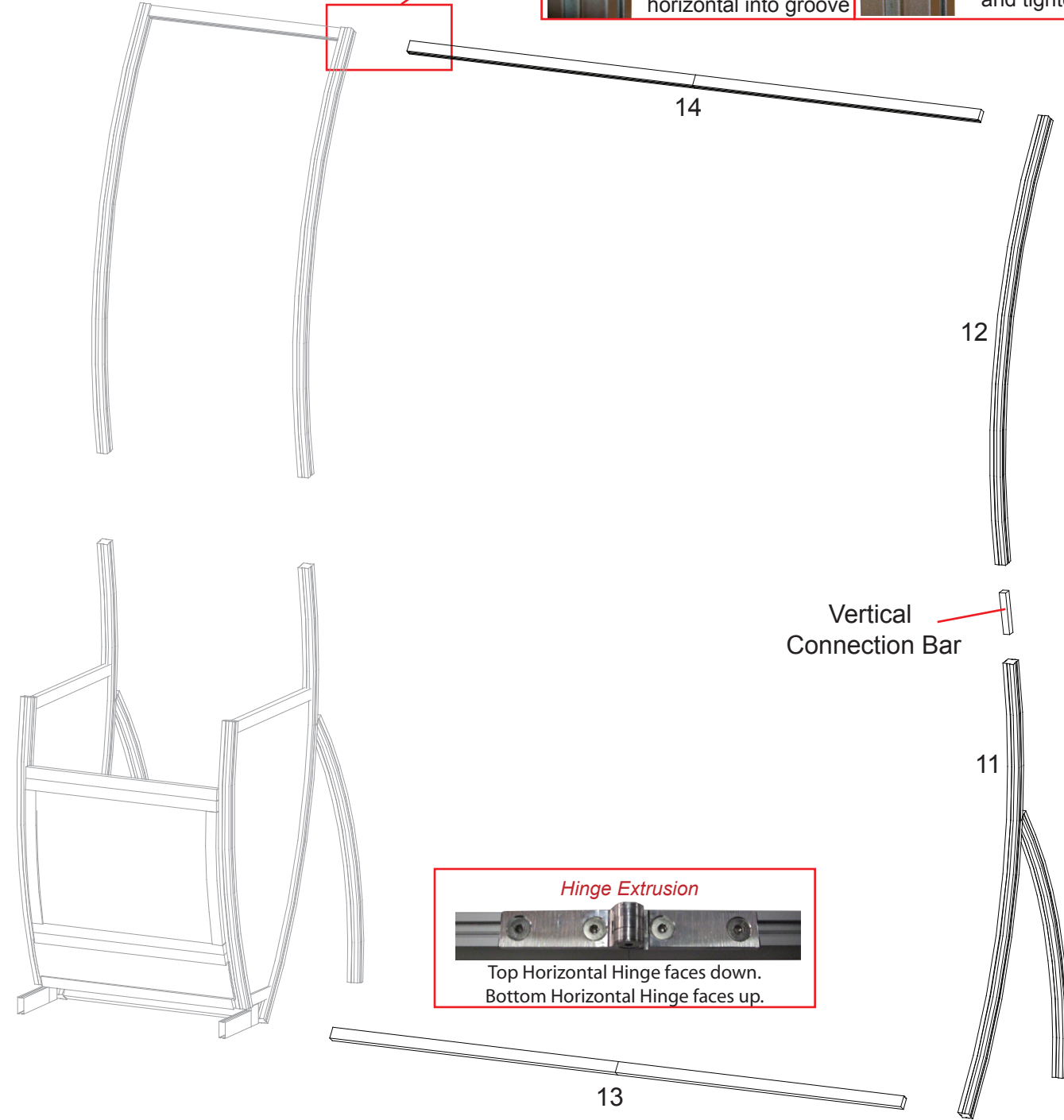
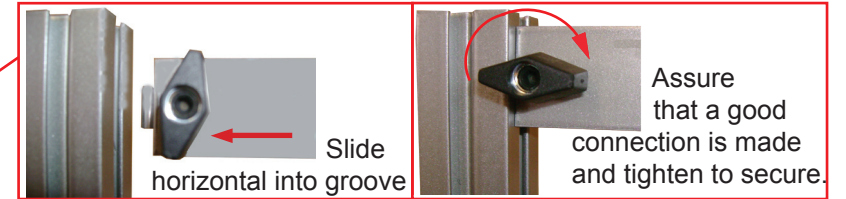

Step stool may be required for assembly.

Rear View of Display

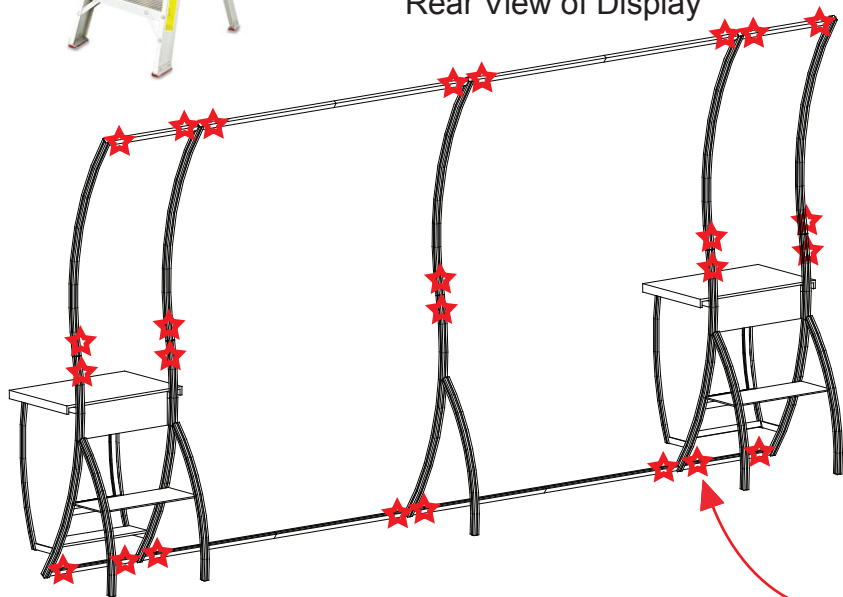

STAR indicates location of knobs on BACKSIDE of unit.

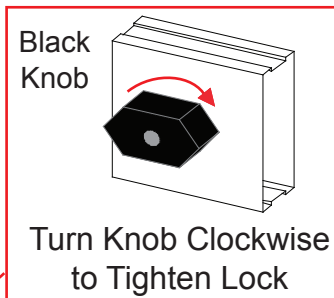

WHEN DISASSEMBLING TIGHTEN ALL KNOBS TO PREVENT LOSS DURING SHIPPING

866.652.2100

Part Number	Description
15	Leg Assembly
16	Upper Curved Vertical
17	69" w Horizontal w/ Hinge Facing UP
18	69" w Horizontal w/ Hinge Facing DOWN

Steps:

NOTE: Can be assembled either face down on floor then lifted upright or upright as shown in drawings.

- 1) Connect lower horizontal [17] between leg assemblies [11 and 15].
- 2) Attach upper verticals to lower verticals, then connect upper horizontal [18] between verticals.

NOTE: Make sure the lock is flush with extrusion before tightening. If lock will not fully engage, gently rock lock and extrusion while turning knob until lock fully opens.



Step stool may be required for assembly.

Rear View of Display

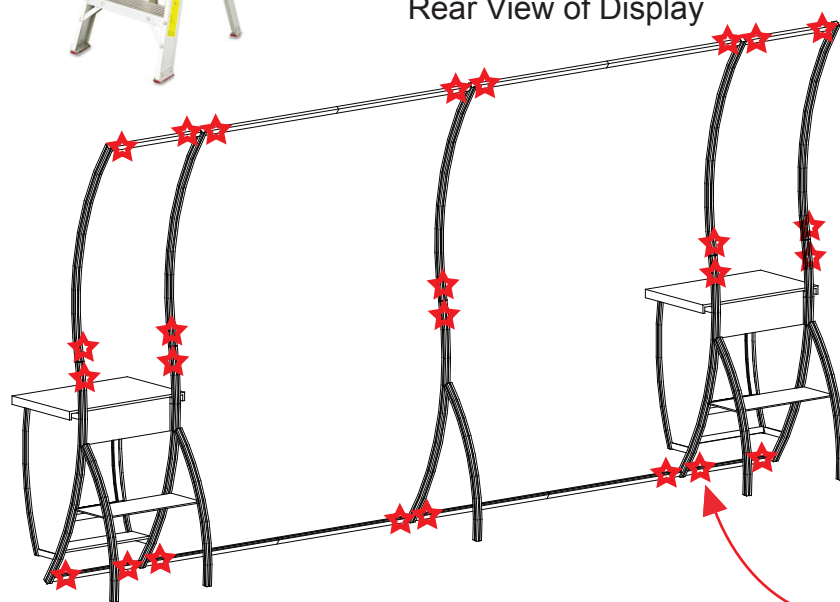

STAR indicates location of knobs on BACKSIDE of unit.

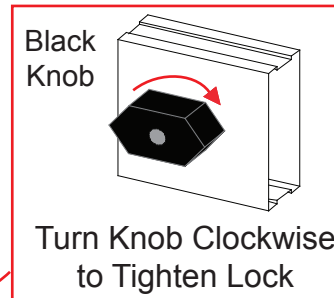

Turn Knob Clockwise to Tighten Lock

Step 3

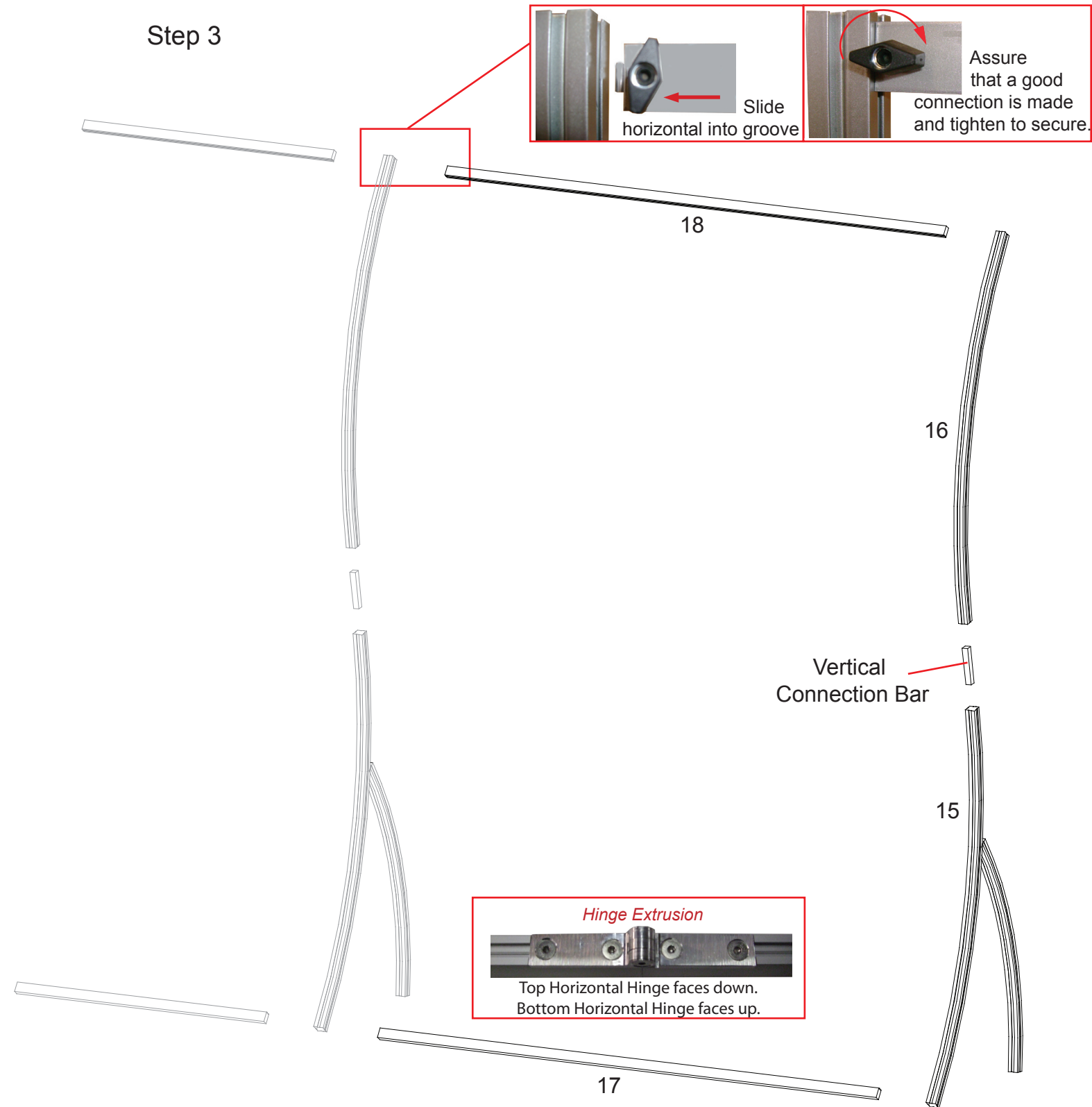

WHEN DISASSEMBLING TIGHTEN ALL KNOBS TO PREVENT LOSS DURING SHIPPING

866.652.2100

Part Number	Description
19	Right Leg Assembly
20	Upper Curved Vertical
21	23" w Horizontal
22	Storage Side Assembly
23	Storage Side Assembly
22a/23a	Support Extrusion
24	23" w Horizontal
25	23" w Horizontal
26	23" w Horizontal

NOTE: When assembling horizontals they should be placed approximately one inch from TOP and BOTTOM.

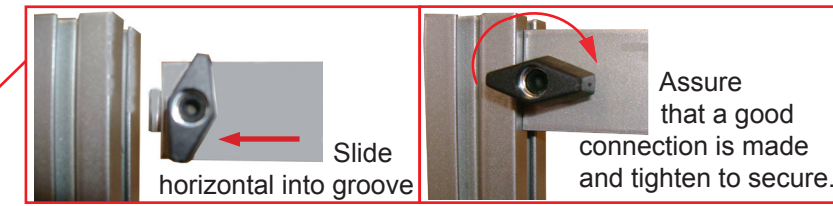

Steps:

NOTE: Can be assembled either face down on floor then lifted upright or upright as shown in drawings.



- 1) Connect lower horizontal [21] between leg assemblies [15 and 19].
- 2) Attach upper verticals to lower verticals, then connect upper horizontal [21] between verticals.
- 3) Attach storage side assemblies with infills to front of legs [15 and 19].
- 4) Attach support pieces [22a and 23a] where indicated, then set floor in place.
- 5) Connect horizontals [24, 25 and 26] between side assemblies, placing infill and attach door between horizontals as shown.

NOTE: Make sure the lock is flush with extrusion before tightening. If lock will not fully engage, gently rock lock and extrusion while turning knob until lock fully opens.

Step 4

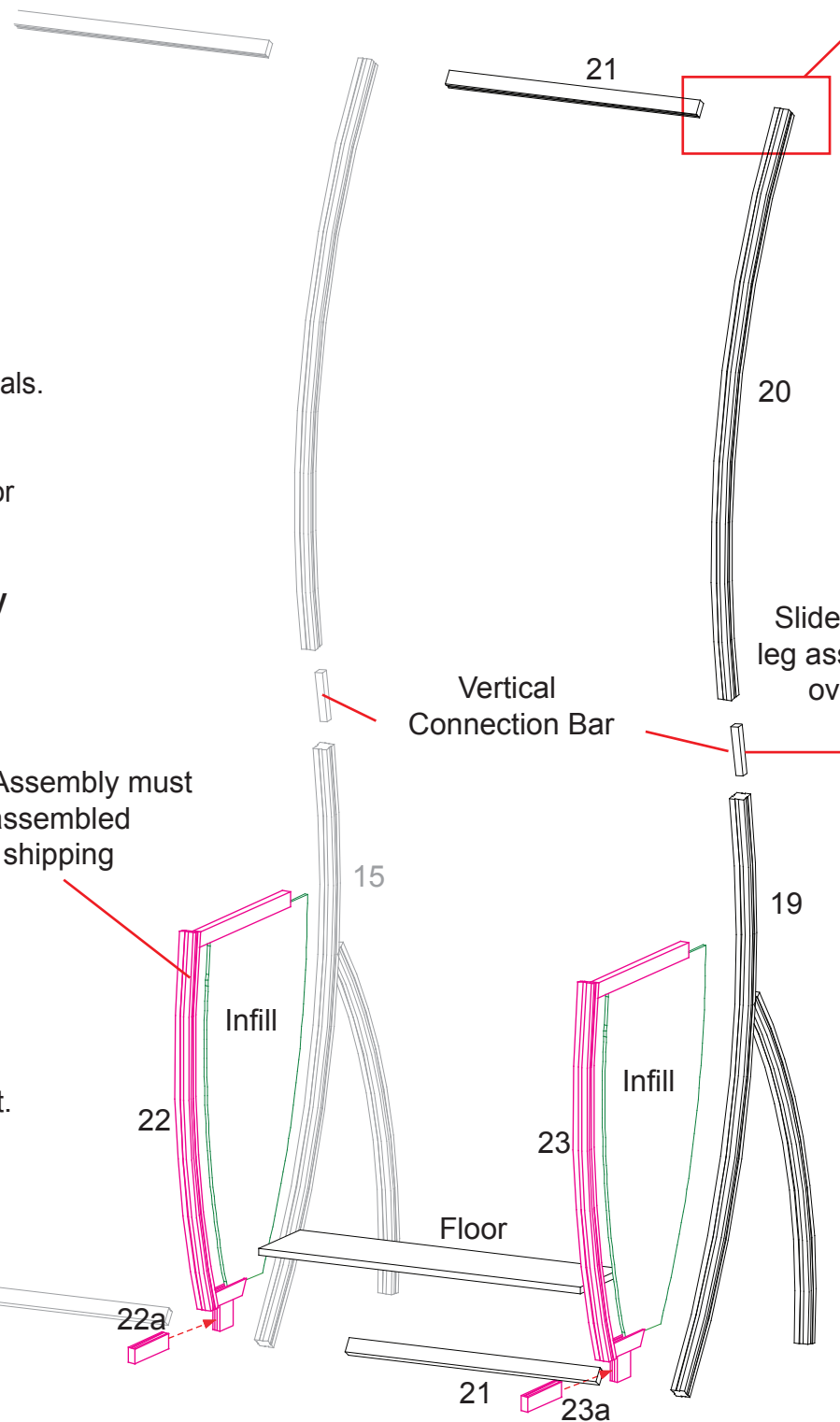

Slide Connection Bar into lower leg assembly. Slide upper vertical over bar and secure both.

Side Assembly must stay assembled when shipping

STAR indicates location of knobs on BACKSIDE of unit.

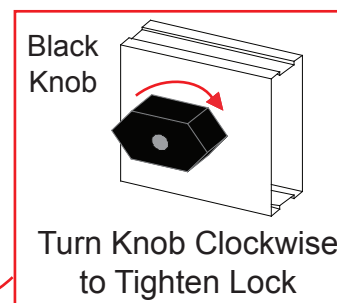

Step stool may be required for assembly.

Rear View of Display

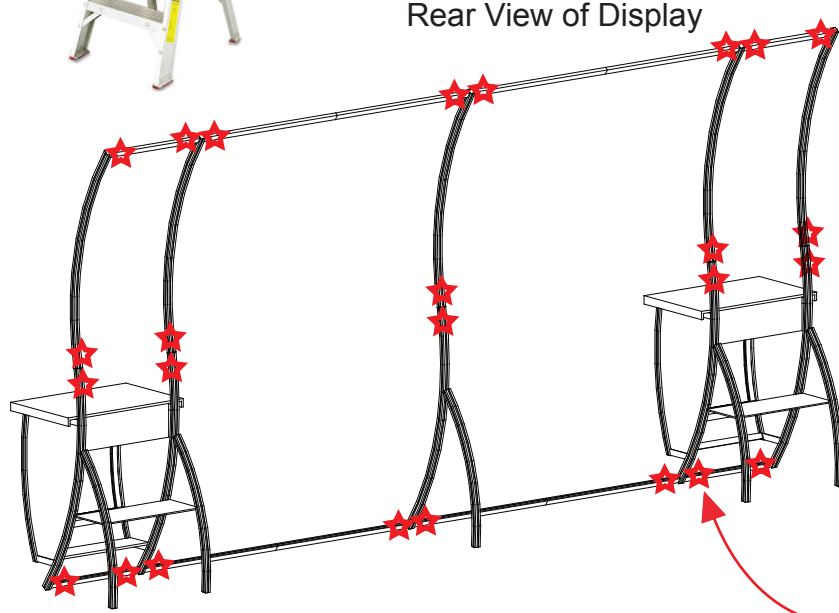

Extrusion 25 stay attached with door

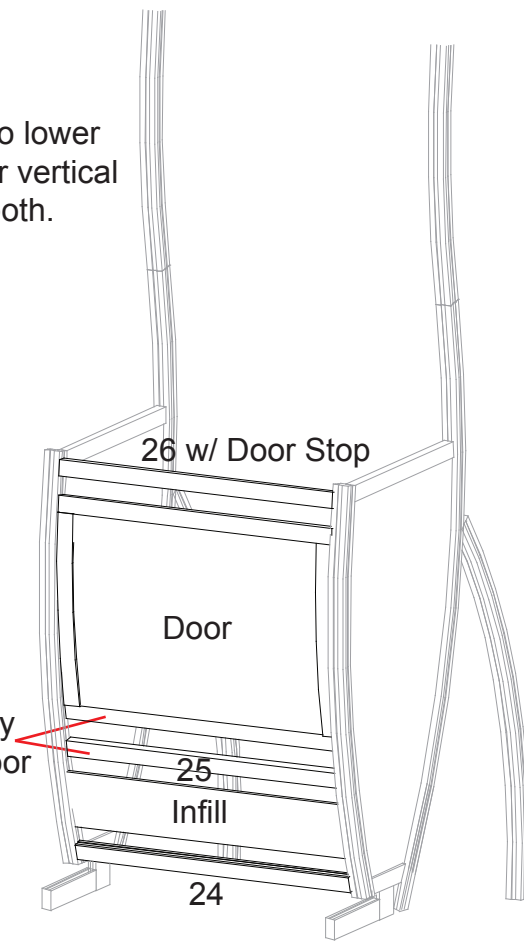

WHEN DISASSEMBLING TIGHTEN ALL KNOBS TO PREVENT LOSS DURING SHIPPING

866.652.2100

Part Number	Description
27	14”h 90° Corner Extrusion
28	14”h 90° Corner Extrusion
29	36”w Horizontal Extrusion
30	36”w Horizontal Extrusion
31	43.249”w Horizontal Extrusion
32	36”w Horizontal Extrusion
33	36”w Horizontal Extrusion
34	Lower Header Support
35	Upper Header Support

Steps:

- 1) Connect horizontal extrusions together [29 thru 33].
- 2) Attach horizontal assemblies between corner extrusions [27 and 28].
- 3) Attach header supports [34 and 35] to pill slots on back of horizontal assemblies and attach header supports [34a and 35a] to verticals [27 and 28].

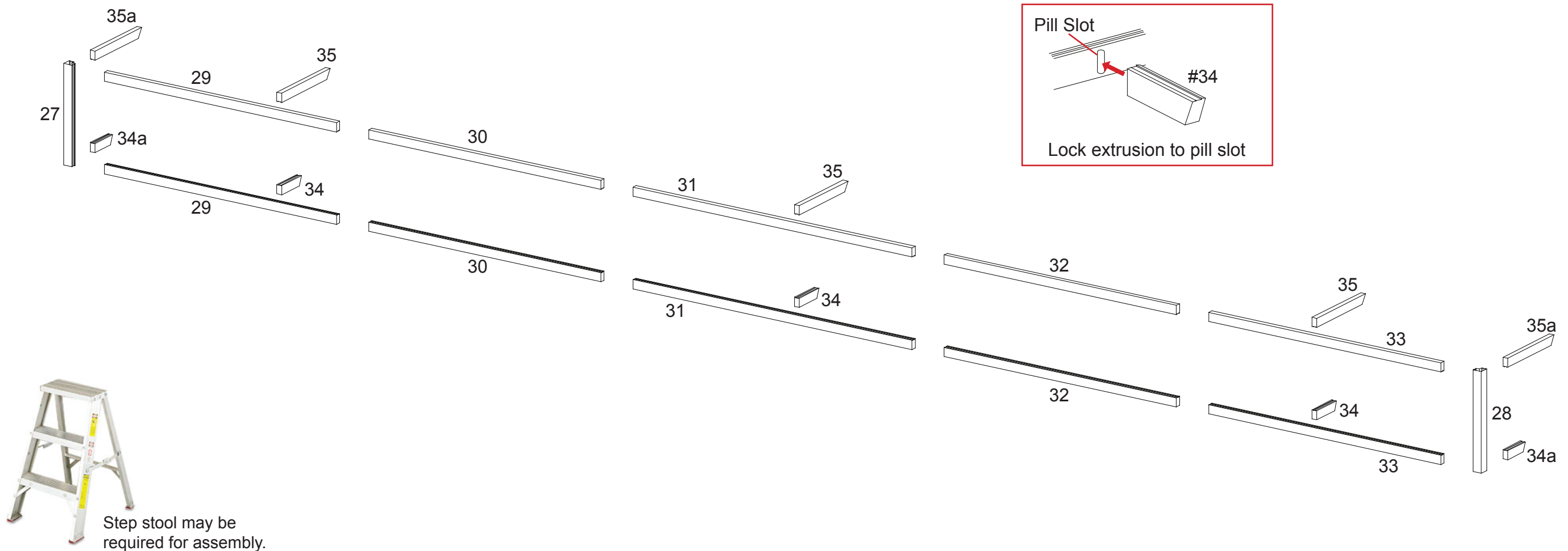

WHEN DISASSEMBLING TIGHTEN ALL KNOBS TO PREVENT LOSS DURING SHIPPING

866.652.2100

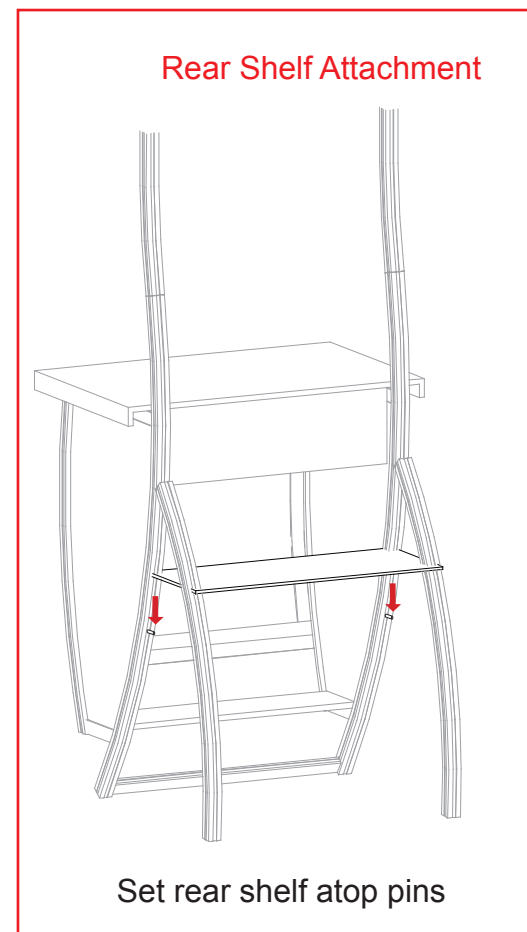
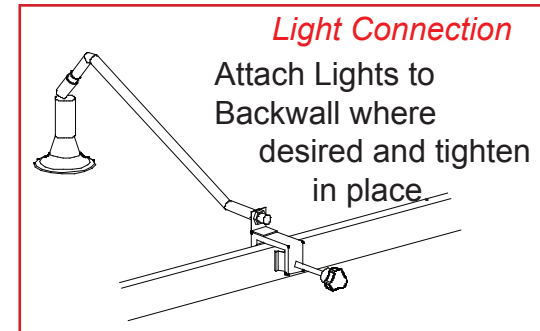
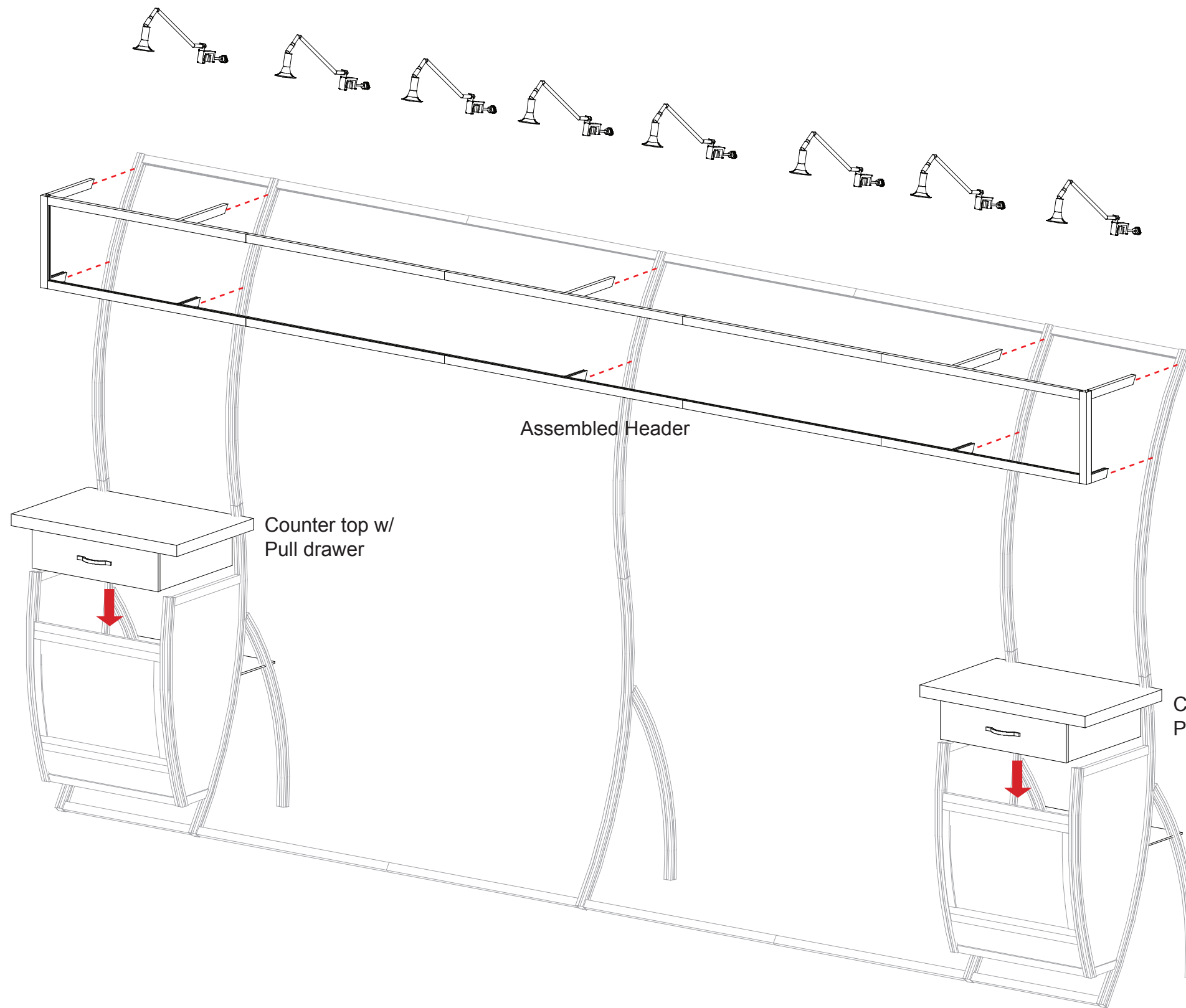

WHEN DISASSEMBLING TIGHTEN ALL KNOBS TO PREVENT LOSS DURING SHIPPING

Part Number	Description
A	Left Leg Assembly
B	Right Leg Assembly
C	Horizontal Extrusion
D	Horizontal Extrusion w/ Door Stopper

Step 1:

- A) Connect lower horizontal extrusion [C] between bottom of leg assemblies [A and B] as shown.
- B) Insert Laminated infill into grooves of leg assemblies [A and B].
- C) Attach extrusion door between leg assemblies [A and B] and atop laminated infill.
- D) Attach upper horizontal extrusion w/ door stopper [D] between leg assemblies [A and B], and set flush with top of legs [A and B].

NOTE: Make sure the lock is flush with extrusion before tightening. If lock will not fully engage, gently rock lock and extrusion back and forth while turning knob until lock fully opens.

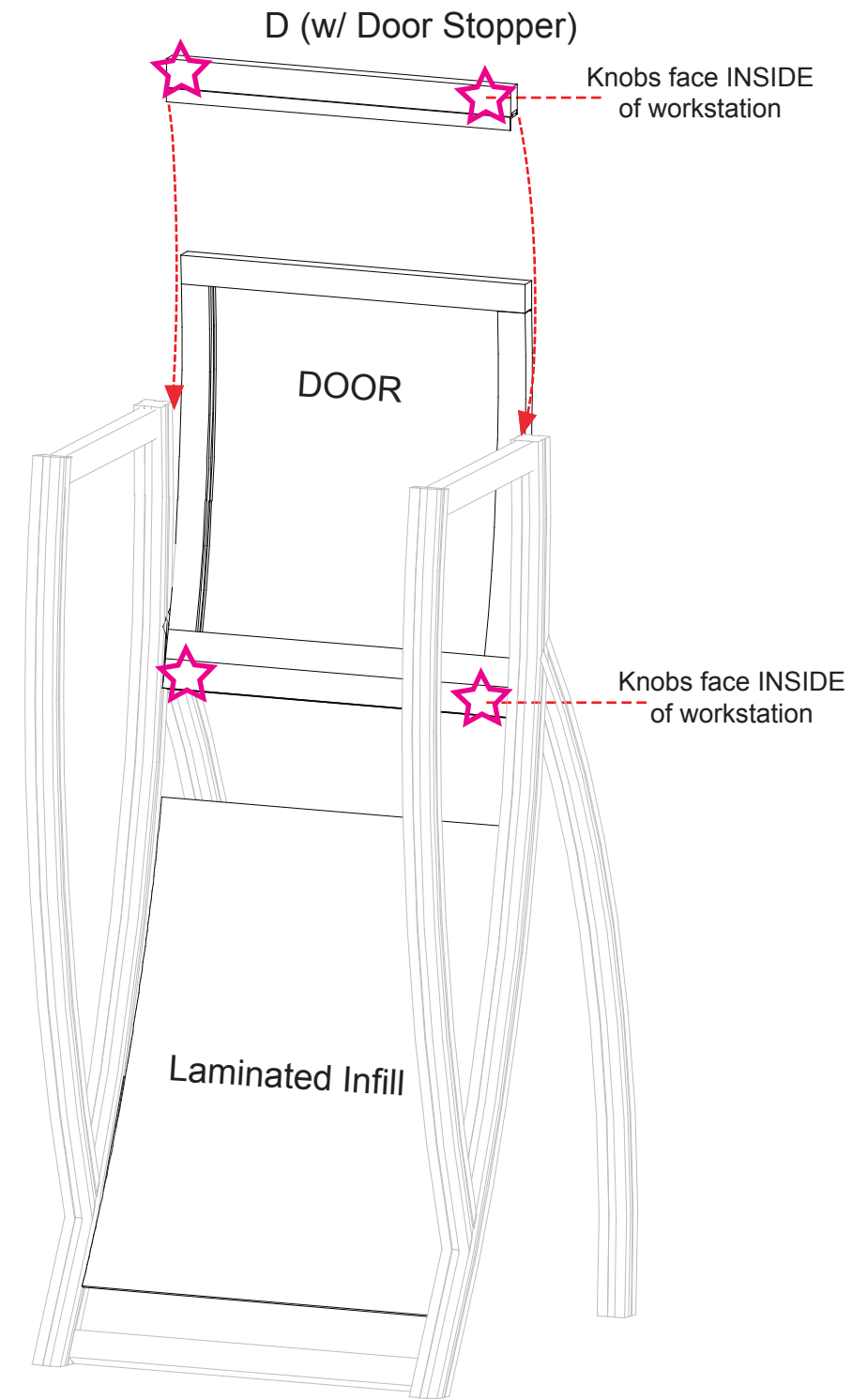
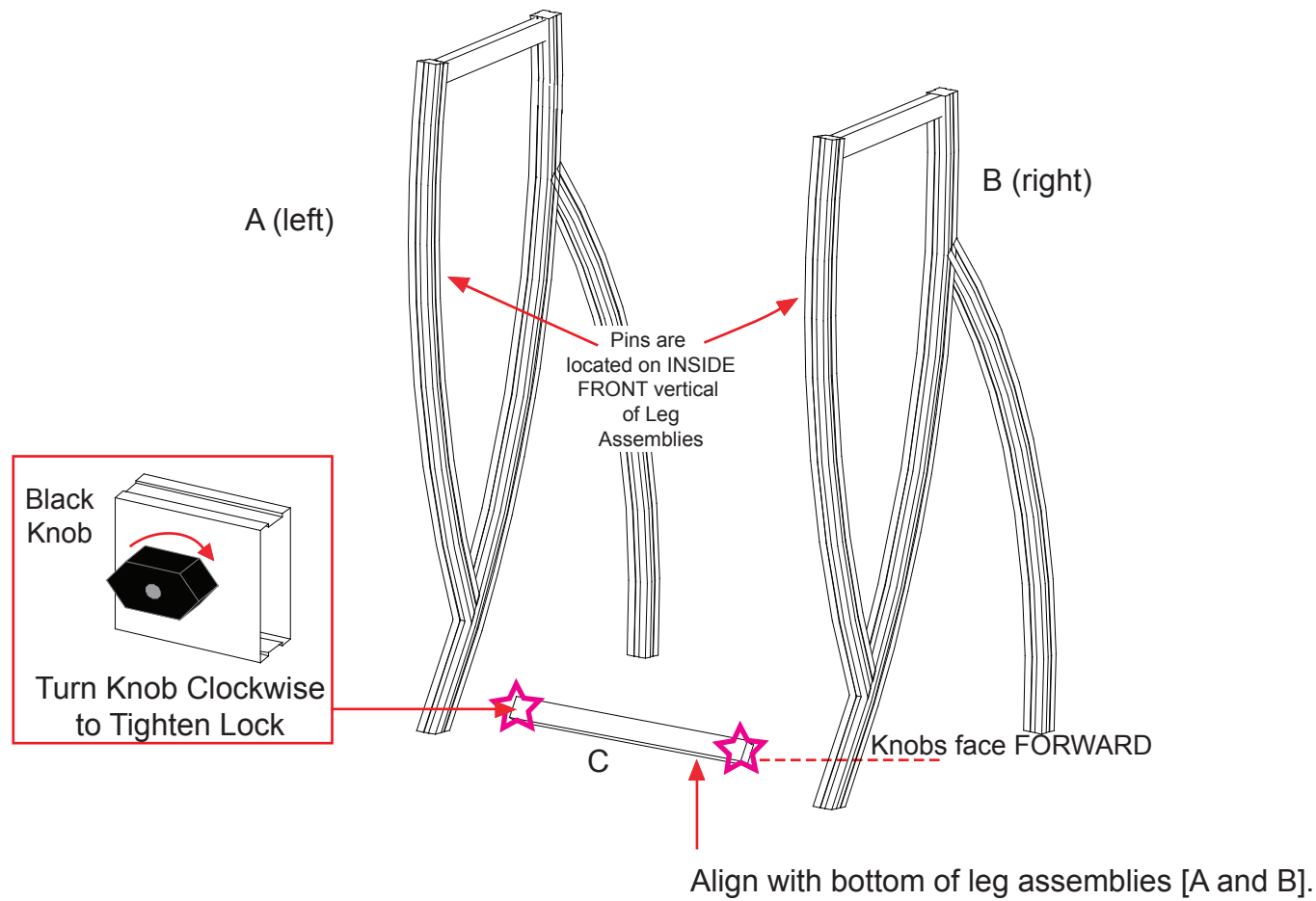

WHEN DISASSEMBLING TIGHTEN ALL KNOBS TO PREVENT LOSS DURING SHIPPING

866.652.2100

Part Number	Description
E	Horizontal Extrusion
F	Horizontal Extrusion

Step 2:

- A) Attach horizontal extrusion [E] between vertical leg assemblies [A and B] as shown below.
- B) Insert Laminated infill into grooves of vertical leg assemblies [A and B].
- C) Attach upper horizontal extrusion [F] between vertical leg assemblies [A and B] atop infill.
- D) Place internal shelf into assembled pedestal atop pins..
- E) Set Counter atop assembled pedestal and secure with Velcro straps attached to underside of top.

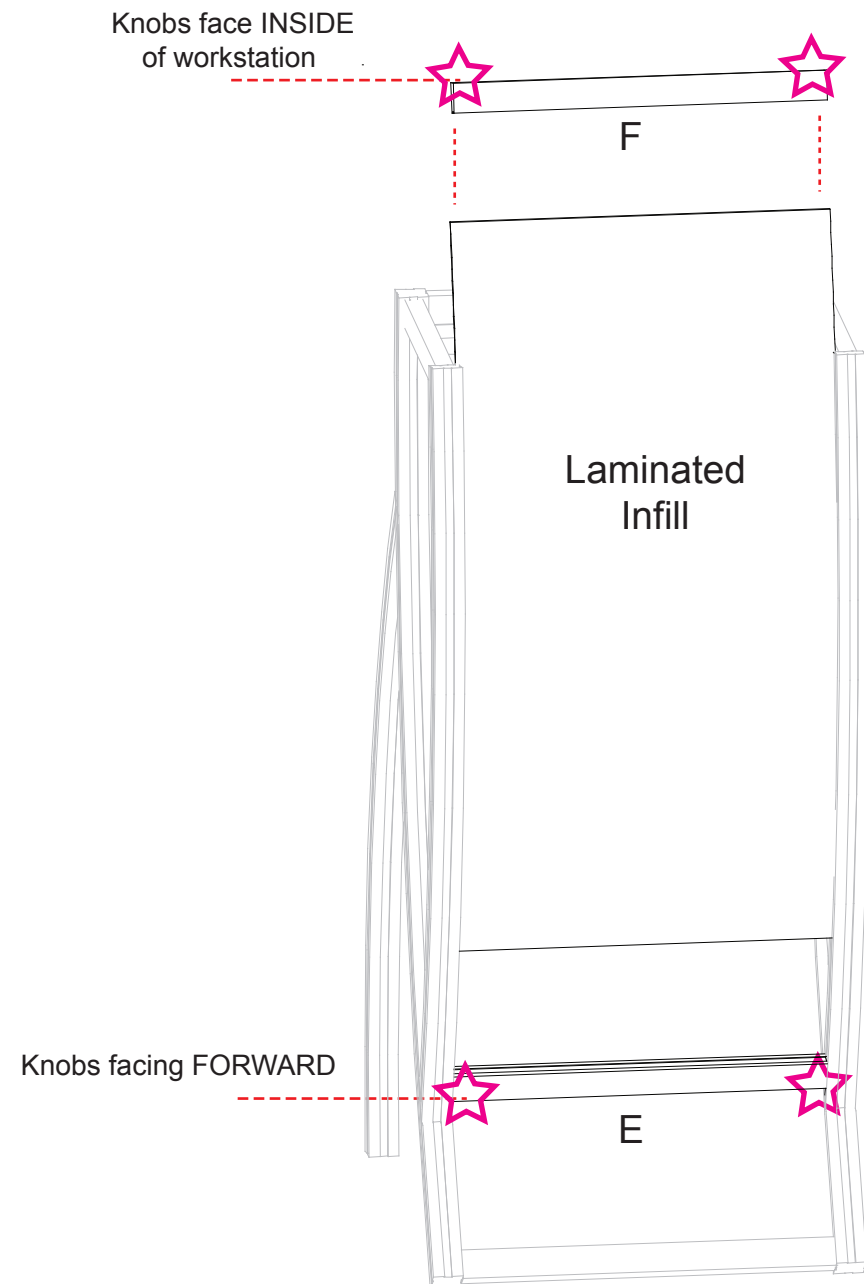

Place internal shelf into workstation then place counter atop assembled workstation.

** Run LED wires inside of shelf

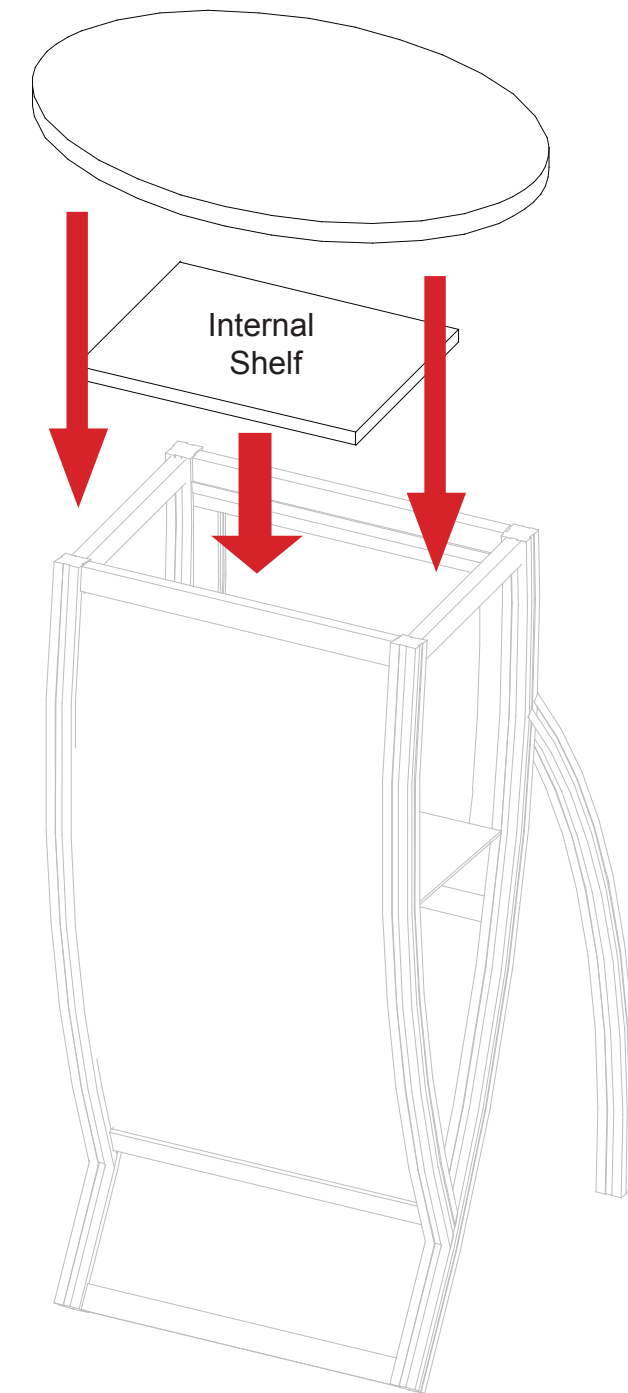

WHEN DISASSEMBLING TIGHTEN ALL KNOBS TO PREVENT LOSS DURING SHIPPING

Case #1 - Backwall Components

Top View of each Layer

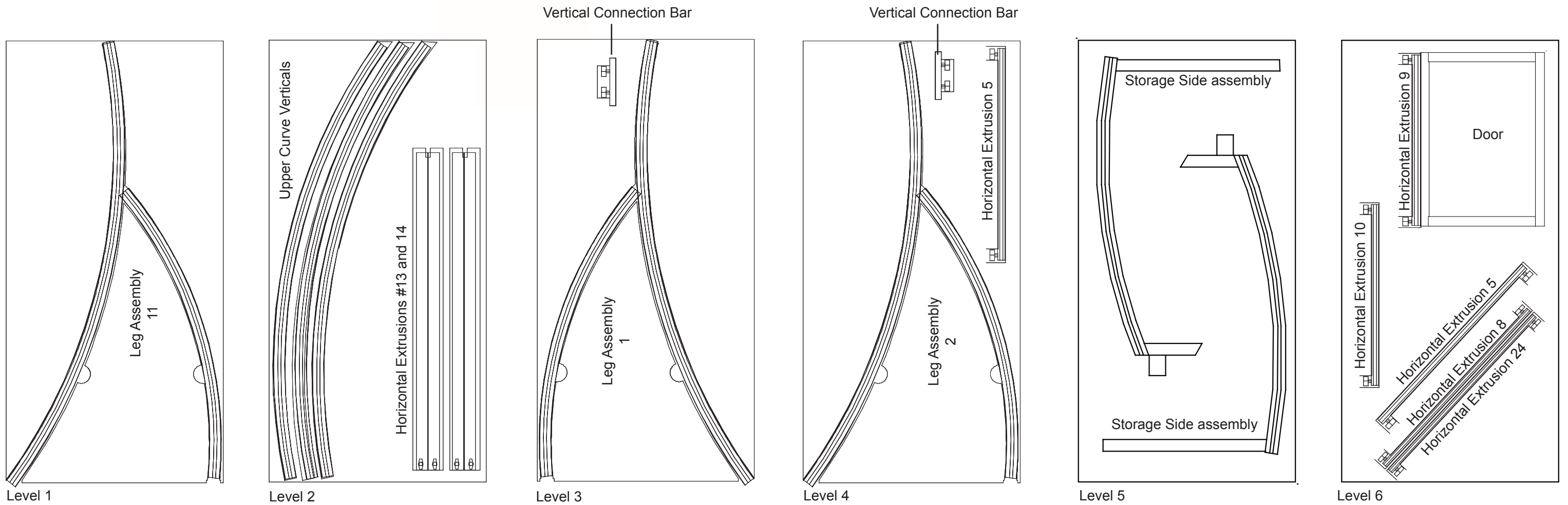

WHEN DISASSEMBLING TIGHTEN ALL KNOBS TO PREVENT LOSS DURING SHIPPING

Case #2 - Backwall Components

Top View of each Layer

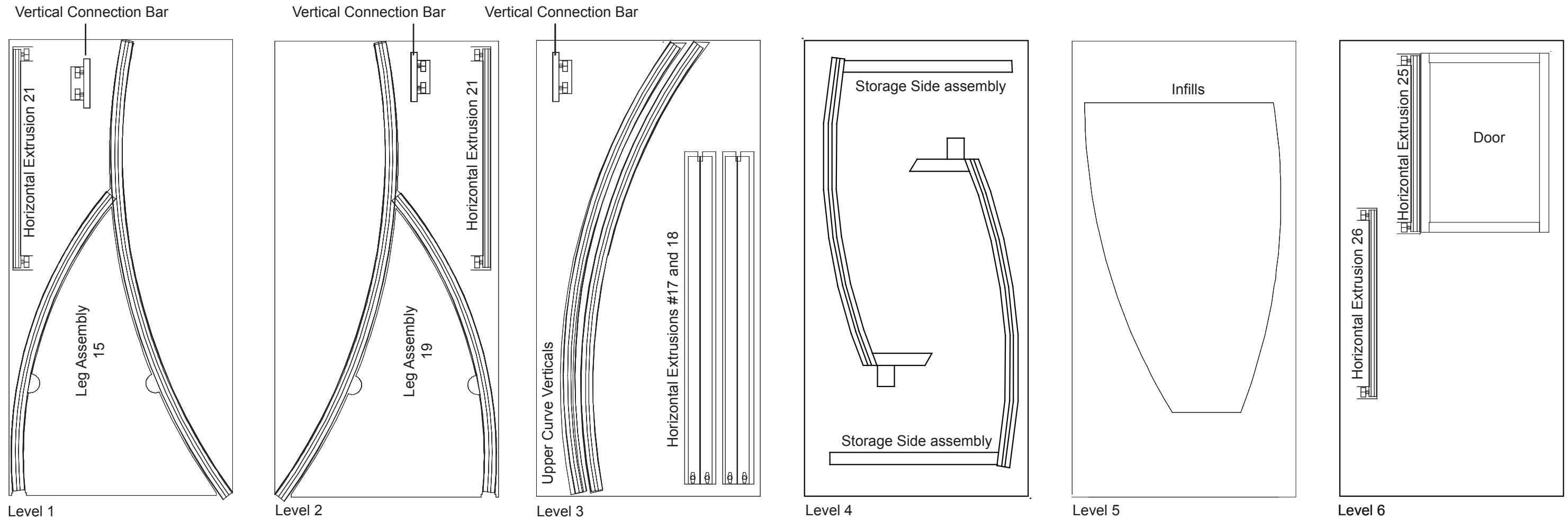

WHEN DISASSEMBLING TIGHTEN ALL KNOBS TO PREVENT LOSS DURING SHIPPING

Case #3 - Backwall Components

Top View of each Layer

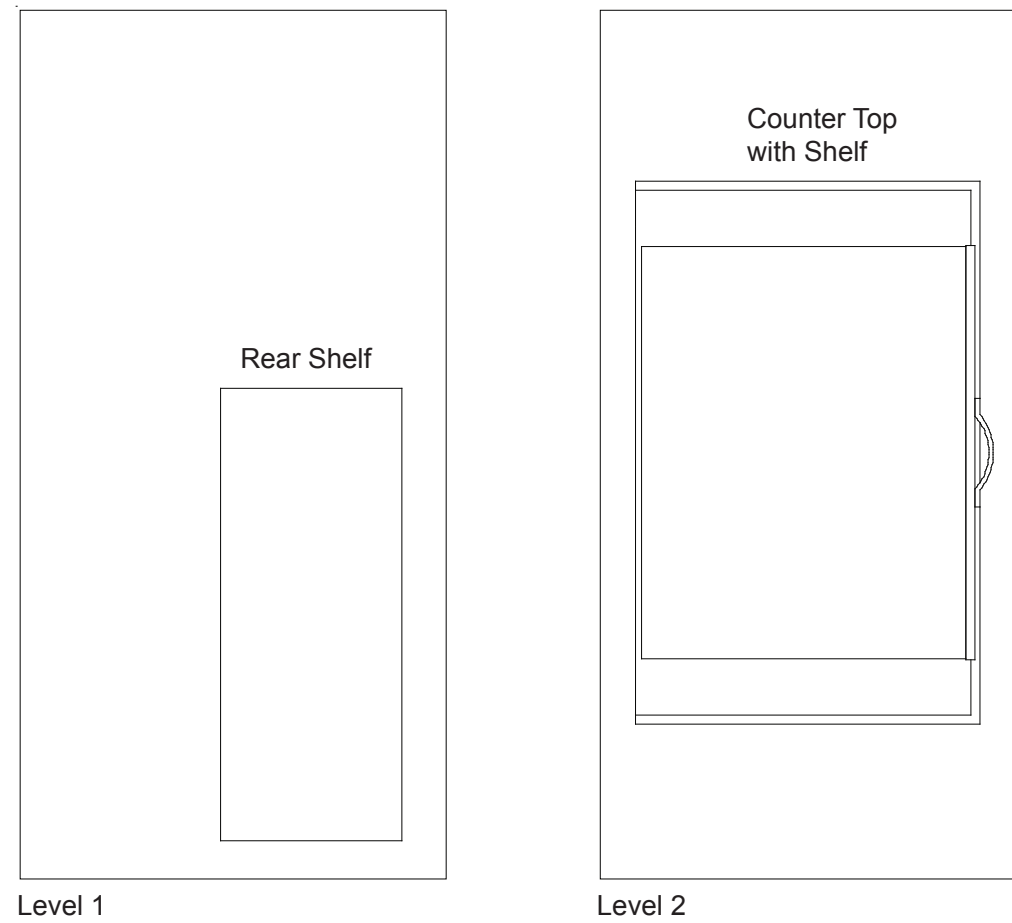

WHEN DISASSEMBLING TIGHTEN ALL KNOBS TO PREVENT LOSS DURING SHIPPING

Case #4 - Backwall Components

Top View of each Level

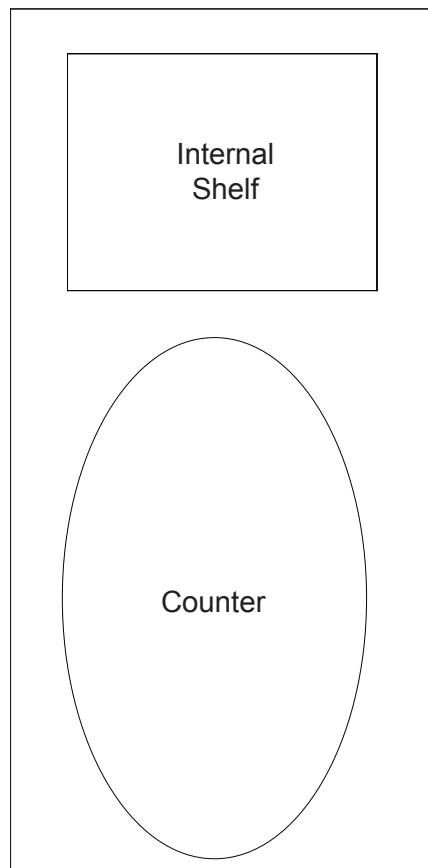

Level 1

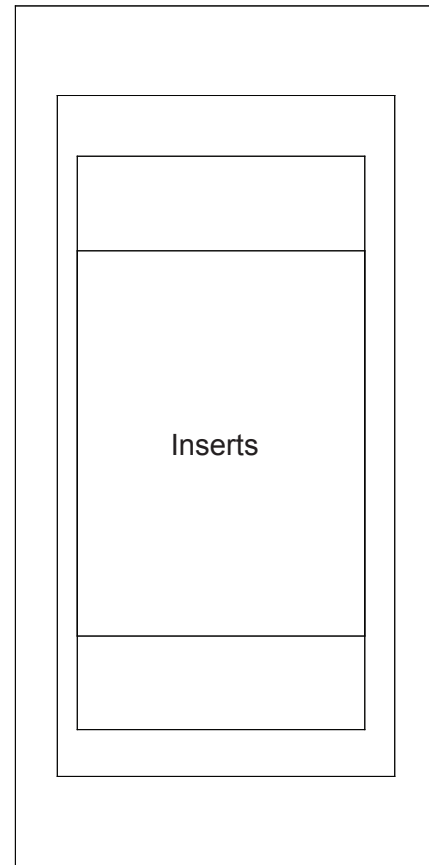

Level 2

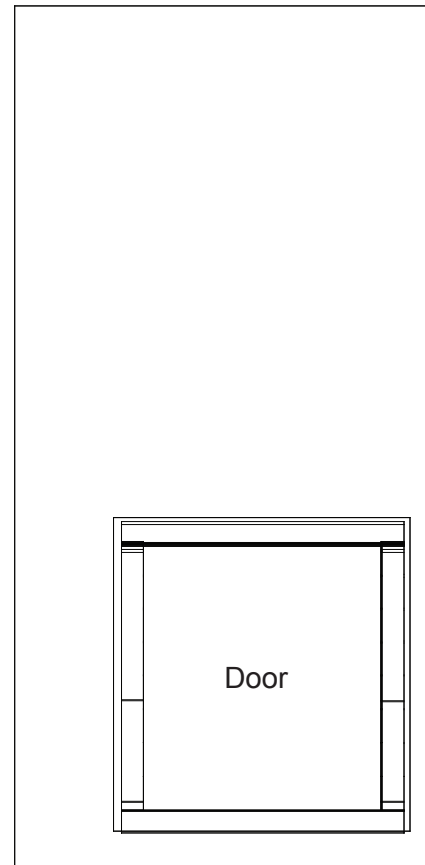

Level 3

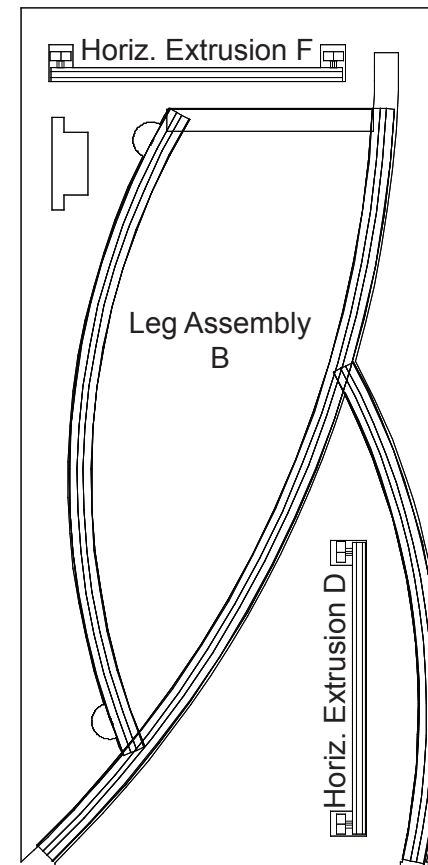

Level 4

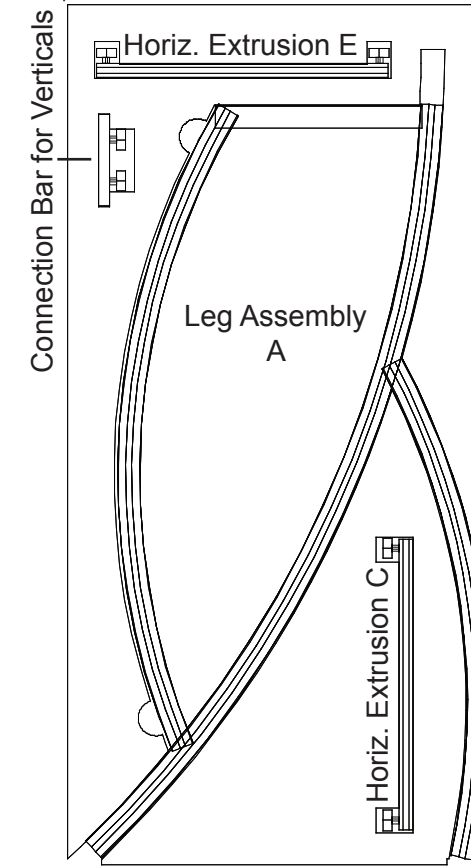

Level 5

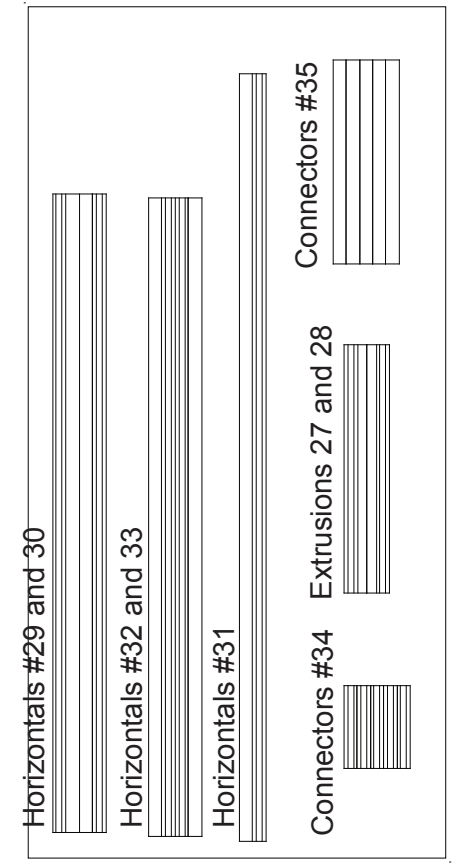

Level 6

WHEN DISASSEMBLING TIGHTEN ALL KNOBS TO PREVENT LOSS DURING SHIPPING

Case #4 - Backwall Components

Top View of each Level

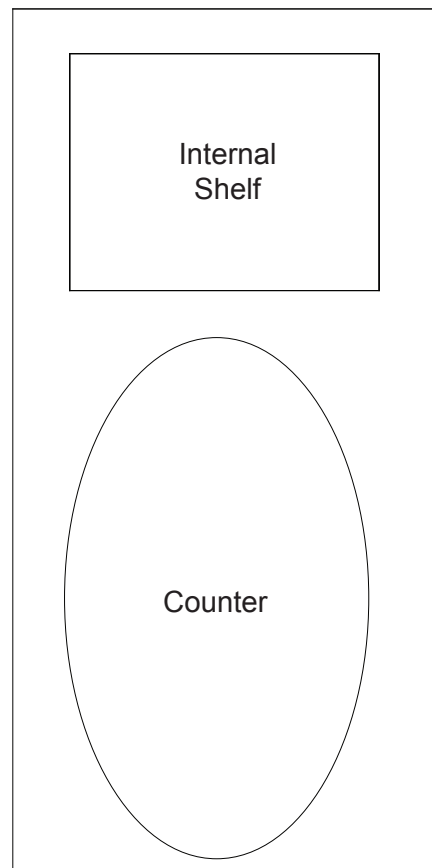

Level 1

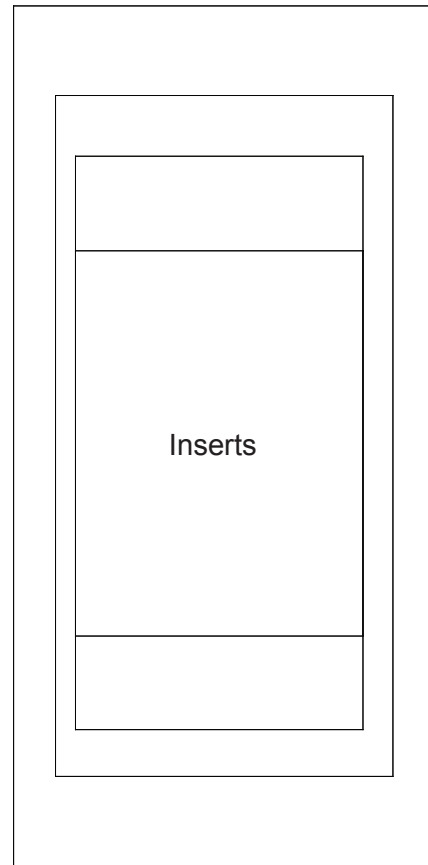

Level 2

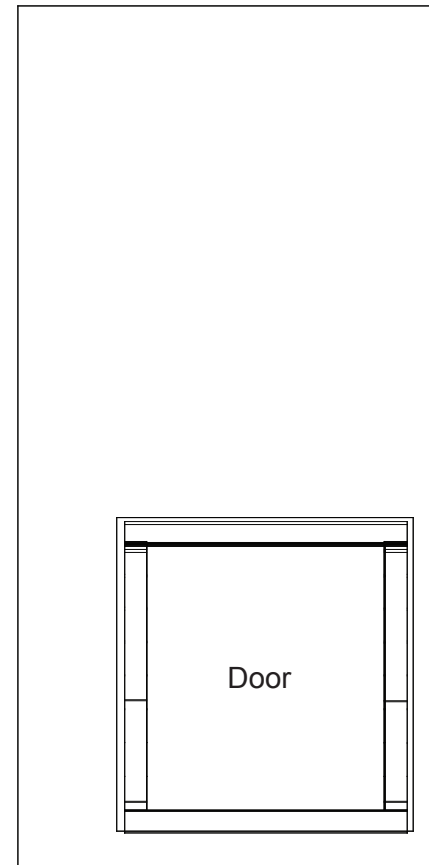

Level 3

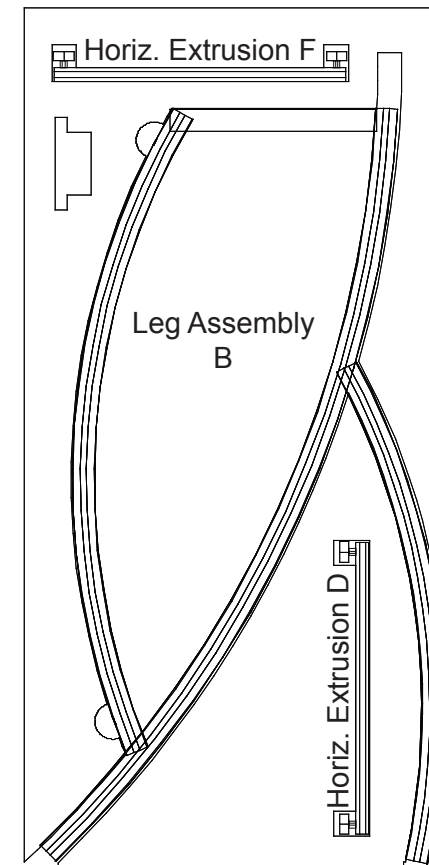

Level 4

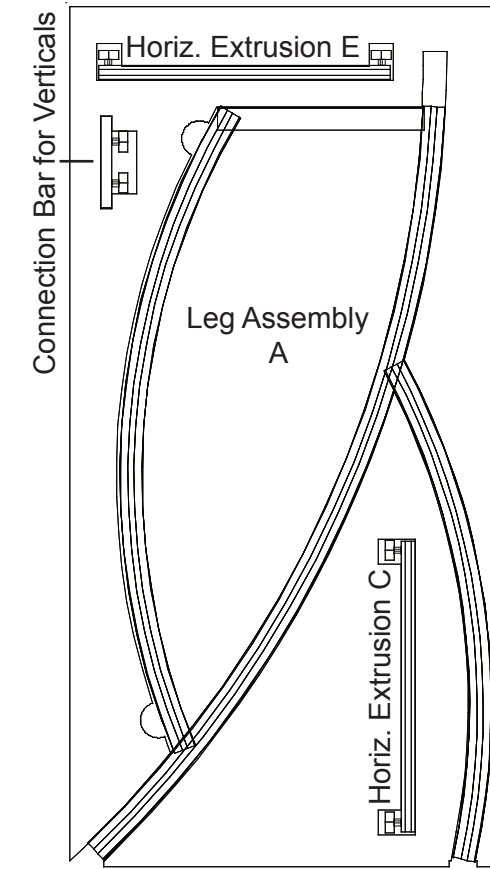

Level 5

WHEN DISASSEMBLING TIGHTEN ALL KNOBS TO PREVENT LOSS DURING SHIPPING

Case #6 - Backwall Components

Top View of each Layer

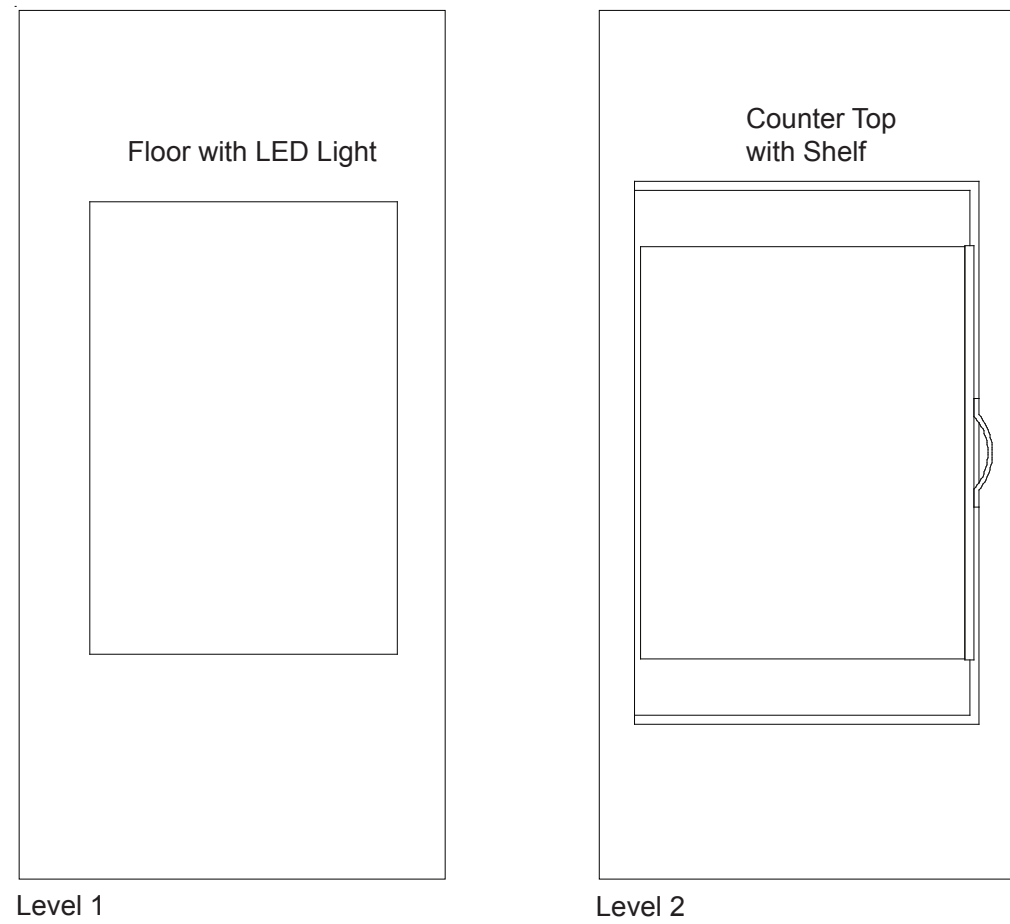

WHEN DISASSEMBLING TIGHTEN ALL KNOBS TO PREVENT LOSS DURING SHIPPING