

WHEN DISASSEMBLING ALUMINUM EXTRUSION, TIGHTEN ALL SETSCREWS AND LOCKS TO PREVENT LOSS DURING SHIPPING

visionary™ DESIGNS

Using Your Setup Instructions

The Visionary Designs Setup Instructions are created specifically for your configuration. They are laid out sequentially, including an exploded view of the entire display, and then a logical series of detailed steps to assemble the main structure and components. We encourage you to study the instructions **before** attempting to assemble your exhibit.

Each page reminds you to tighten the setscrews after disassembling your exhibit to prevent loss of the locks and setscrews (see below in RED). This is **VERY IMPORTANT**.

Cleaning and Packing Your Display

- 1) Use care when cleaning aluminum extrusion or acrylic inserts. Use only non-abrasive cleaners.
- 2) When cleaning laminate inserts or countertops, use mild cleansers and a soft material such as cotton.
- 3) Keep all display components away from extreme heat and long exposure to sunlight to avoid warping and fading.
- 4) Retain all packing material. It will make re-packing much easier and will reduce the likelihood of shipping damage.



The Tool

Most Visionary Designs exhibits can be assembled with the supplied Hex Key Tool. Occasionally, a flat head screwdriver may be required.



Detail A

Typical Connection



Typical Connection (cont'd)

Most horizontal extrusion connections have a patented expandable lock. This lock inserts into the groove of an opposing extrusion. Tightening the lock with the Hex Key Tool expands the lock and creates a strong positive connection.

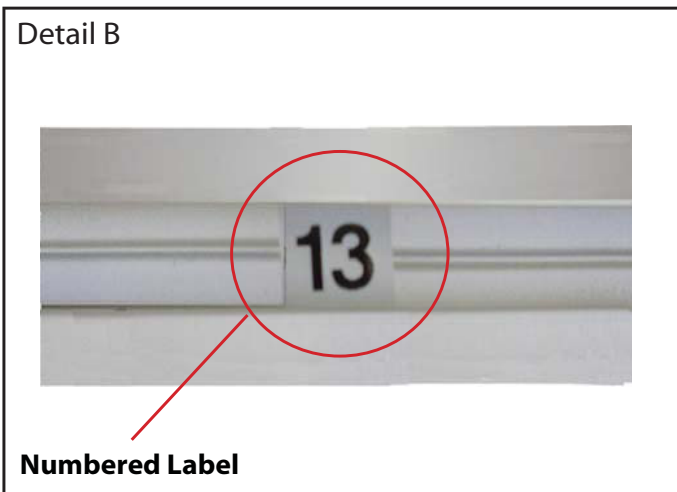

Detail B

Numbered Label

Each extrusion contains a numbered label which corresponds with setup instructions. The label is located within a groove of the extrusion (when possible). With Visionary Designs the labels contain Black numbers unless otherwise specified.



Detail C

Horizontal Inline Connection (remove only one setscrew)

Remove only (1) setscrew when disassembling. Replace setscrew in extrusion after assembling it. Before packing, replace setscrew in extrusion to avoid losing it.

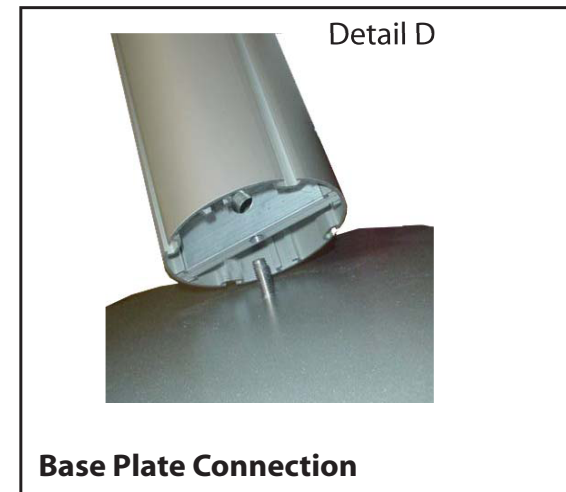

Detail D

Base Plate Connection

Attach base plate to round or square vertical extrusion using the bolt provided. Be careful not to strip the threads.

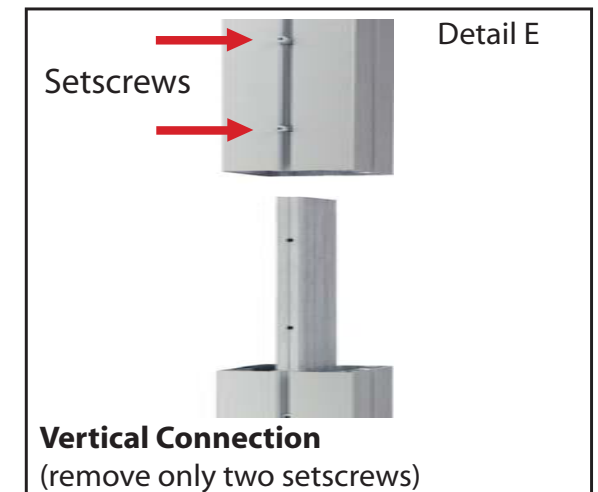

Detail E

Vertical Connection
(remove only two setscrews)

When vertical extrusions are packed in portable cases rather than crates or tubs, they must be broken down into smaller sections which then require assembly.

Remove only (2) setscrews when disassembling. Replace setscrews in extrusion after assembling it. Before packing, replace setscrews in extrusion to avoid losing them.

WHEN DISASSEMBLING ALUMINUM EXTRUSION, TIGHTEN ALL SETSCREWS AND LOCKS TO PREVENT LOSS DURING SHIPPING

866.652.2100

Item	Qty.	Description	Item	Qty.	Description
1	6	Base Plate	12	1	42"h Lower Vertical Extrusion
2	1	42"h Lower Vertical Extrusion	13	1	42"h Upper Vertical Extrusion
3	1	42"h Upper Vertical Extrusion	14/14a/14b	2/1/1	22"w Horizontal Extrusion
4	1	42"h Lower Vertical Extrusion	15a/15b	1/1	28.875"w Horizontal Extrusion
5	1	42"h Upper Vertical Extrusion	16a/16b	1/1	28.875"w Horizontal Extrusion
6	1	42"h Lower Vertical Extrusion	17a/17b	1/1	25.125"w Horizontal Extrusion
7	1	42"h Upper Vertical Extrusion	18a/18b	1/1	25.125"w Horizontal Extrusion
8	1	42"h Lower Vertical Extrusion	19a/19b	1/1	25.125"w Horizontal Extrusion
9	1	42"h Upper Vertical Extrusion	20a/20b	1/1	28.875"w Horizontal Extrusion
10	1	42"h Lower Vertical Extrusion	21a/21b	1/1	28.875"w Horizontal Extrusion
11	1	42"h Upper Vertical Extrusion	22a/22b	1/1	28.875"w Horizontal Extrusion

- Steps:
- 1) Attach lower vertical extrusions to base plates [1].
 - 2) Attach upper vertical extrusions atop lower vertical extrusions as shown.
 - 3) Connect horizontal extrusions [a and b] together.
 - 4) Connect horizontal assemblies between vertical assemblies as shown.
 - 5) Apply backwall graphics to assembled backwall.

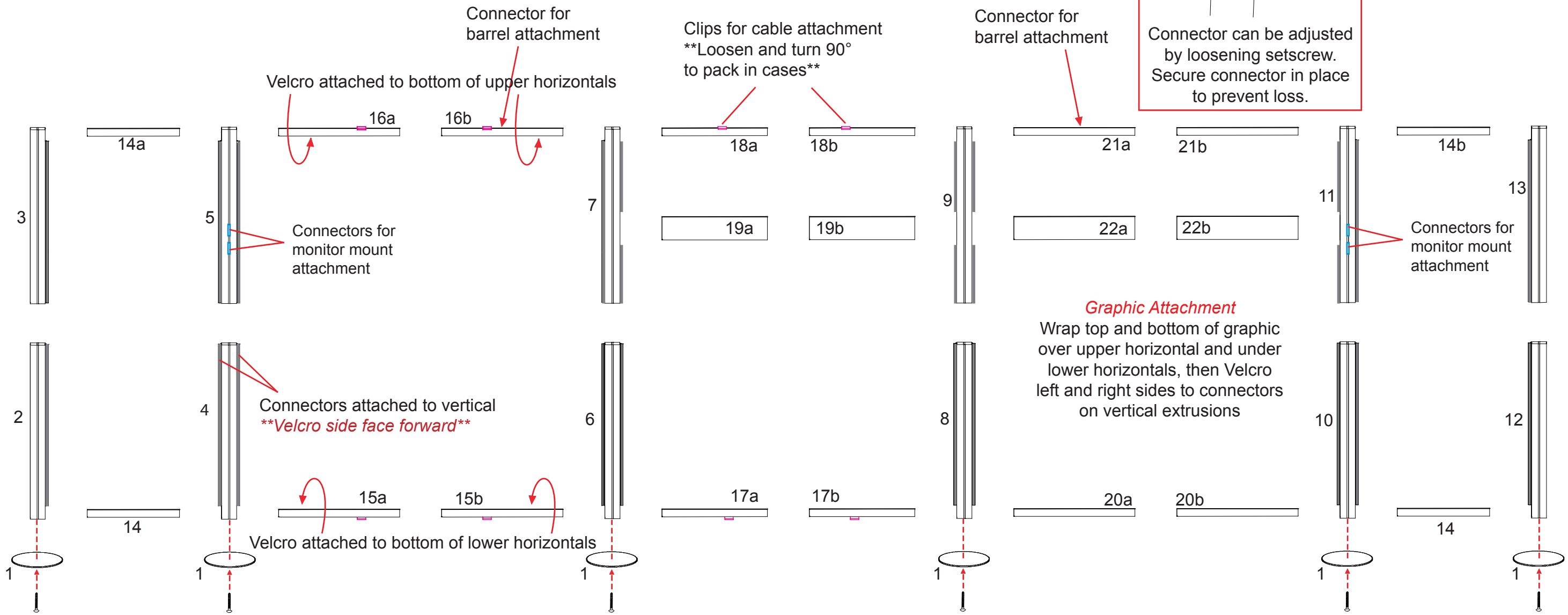

WHEN DISASSEMBLING ALUMINUM EXTRUSION, TIGHTEN ALL SETSCREWS AND LOCKS TO PREVENT LOSS DURING SHIPPING

866.652.2100

Item	Qty.	Description
23	1	10.815"h Vertical Extrusion
24	1	10.815"h Vertical Extrusion
25a/25b	1/1	38.99"w Horizontal Extrusion
26a/26b	1/1	39.3974" Curve Horizontal Extrusion

- Steps:
- 1) Assemble header frame by connecting horizontal pieces together [25a to 25b and 26a to 26b], then attach horizontal assemblies between verticals [23 and 24].
 - 2) Lock assembled header to top of assembled frame.
 - 3) Clamp halogen lights to top of assembled backwall where indicated.

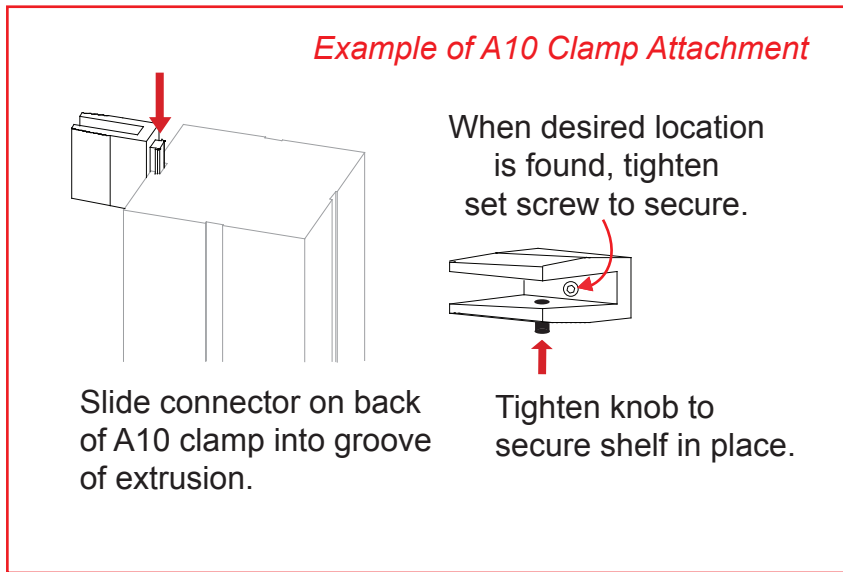
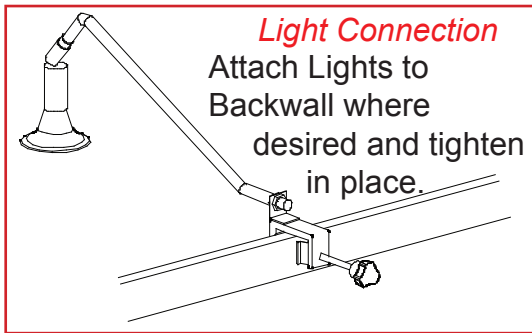
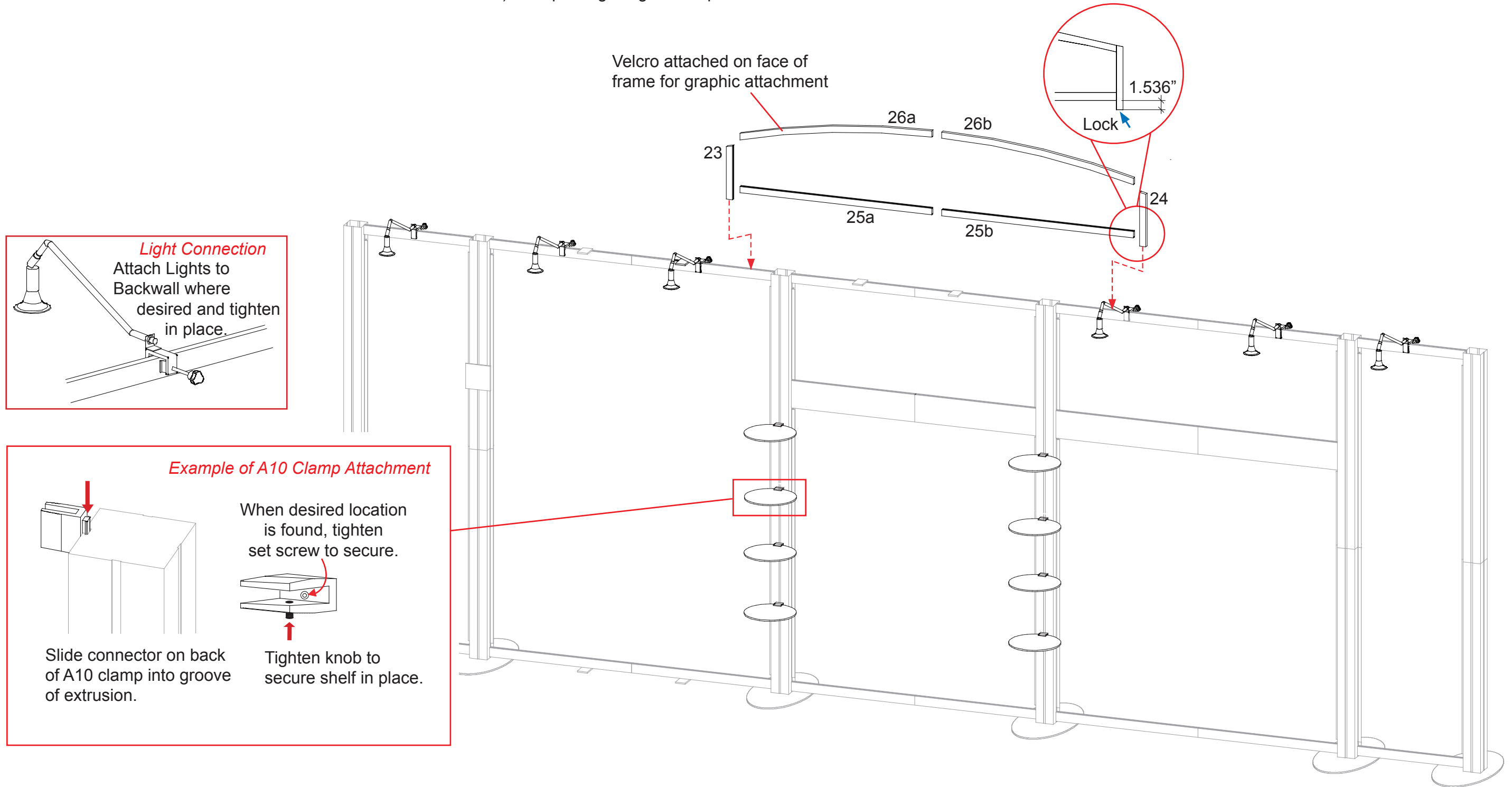

WHEN DISASSEMBLING ALUMINUM EXTRUSION, TIGHTEN ALL SETSCREWS AND LOCKS TO PREVENT LOSS DURING SHIPPING

866.652.2100

Item	Qty.	Description
27	1	38" h Vertical Extrusion
28	1	38" h Vertical Extrusion
29	2	32" w Horizontal Extrusion
30a/30b	1/1	45.99" w Curve Extrusion
31a/31b	1/1	45.99" w Curve Extrusion

Steps:

- 1) Connect horizontal extrusions [29] between vertical extrusions [12 and 27].
- 2) Connect horizontal extrusions [30a to 30b and 31a to 31b] together.
- 3) Connect horizontal assemblies [30a/30b and 31a/31b] between vertical extrusions [27 and 28].
- 4) Attach monitor mounts to assembled backwall where indicated.

Attach turnbuckles on both ends of cable to plates on upper and lower horizontals using bolts

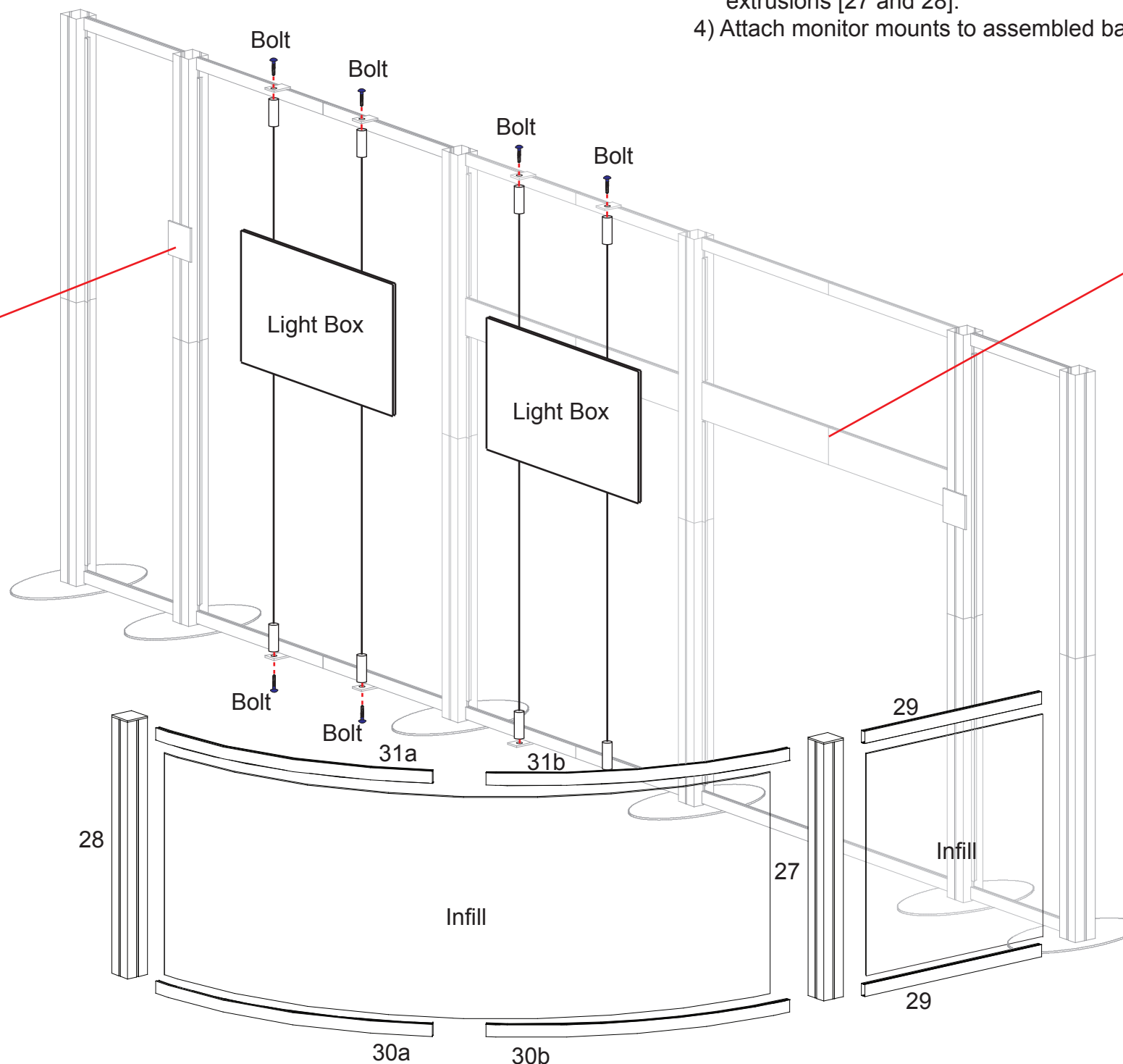

Monitor Mount Attachment

Slide mounting connector pieces into groove of extrusion. Tighten setscrew to secure in place.

Attach back plate to connectors on vertical extrusion using screws. Then attach top plate and tighten setscrews to secure.

Monitor Mount Attachment

Then attach wall plate to plate using bolts and secure with wing nuts

WHEN DISASSEMBLING ALUMINUM EXTRUSION, TIGHTEN ALL SETSCREWS AND LOCKS TO PREVENT LOSS DURING SHIPPING

866.652.2100



Using Your Setup Instructions

The Aero Overhead Sign Setup Instructions are created specifically for your configuration. They include an exploded view of the frame which is sequentially numbered. We encourage you to study the instructions before attempting to assemble your exhibit.

Connections are kept very simple: no tools. Everything assembles with push-button connectors and pre-connected horizontal sections.

Cleaning and Packing Your Display

- 1) Use care when cleaning aluminum extrusion or acrylic inserts. Use only non-abrasive cleaners.
- 2) Retain all packing material. It will make re-packing much easier and will reduce the likelihood of shipping damage.

Steps:

- 1) Connect canopy pieces together as shown.
- 2) Apply pillow case graphic to assembled canopy.
- 3) Drop canopy legs on white plastic barrels.

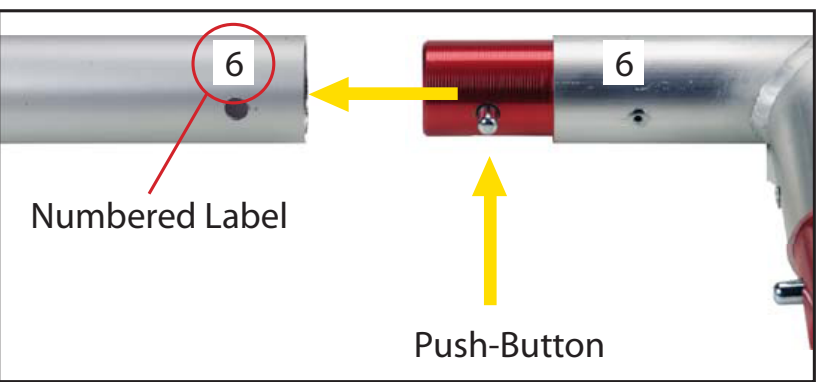
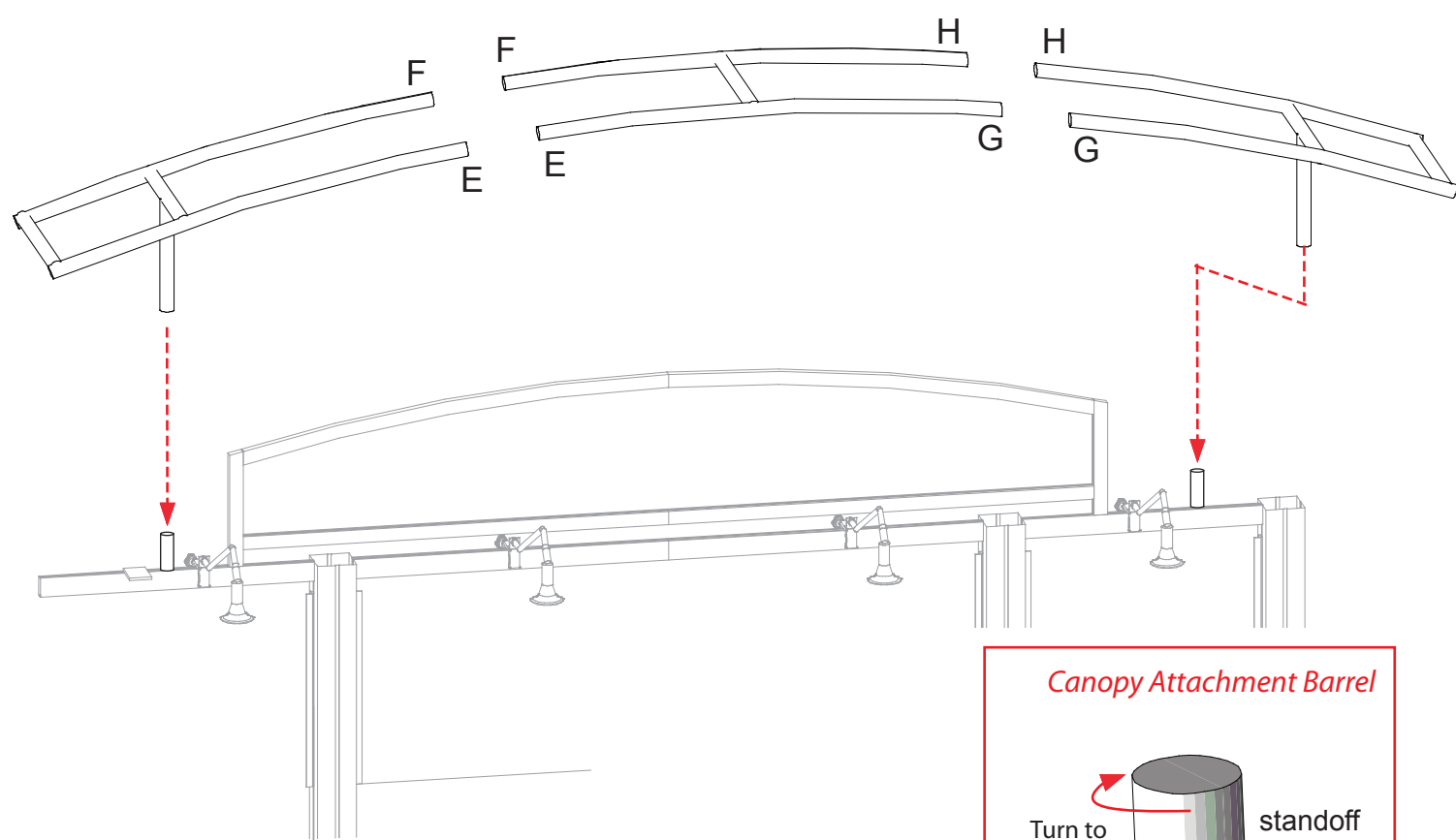

Connections are made by holding the button down and sliding the red tube into opposing tube until the connection is made. To disassemble push button and pull or twist extrusions apart.

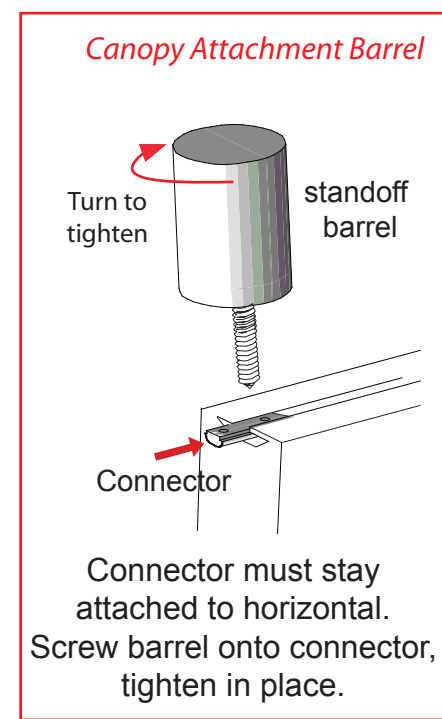
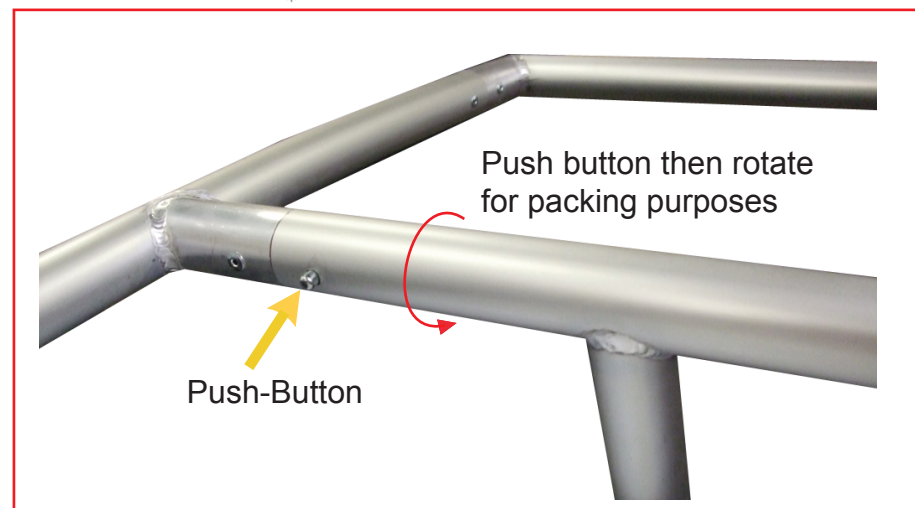
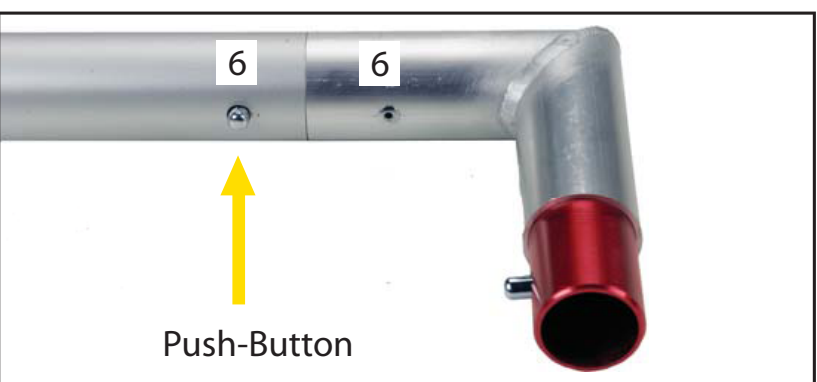

WHEN DISASSEMBLING ALUMINUM EXTRUSION, TIGHTEN ALL SETSCREWS AND LOCKS TO PREVENT LOSS DURING SHIPPING

Top View of each Level

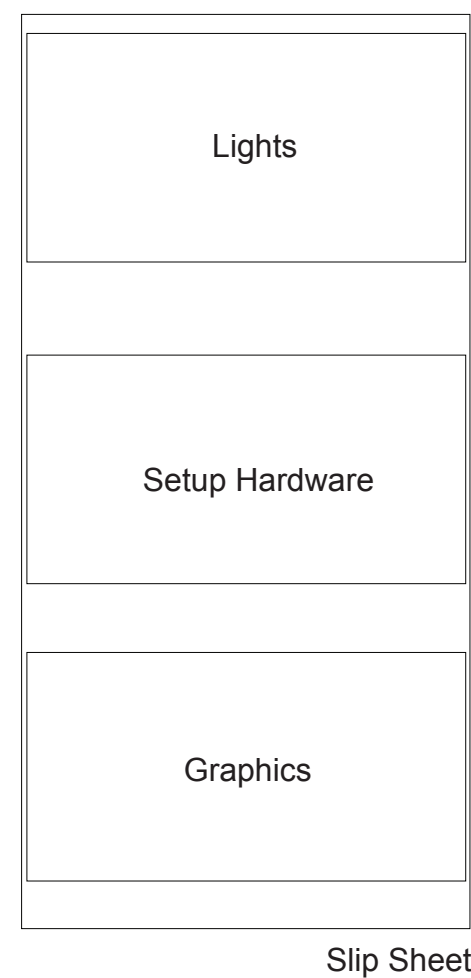
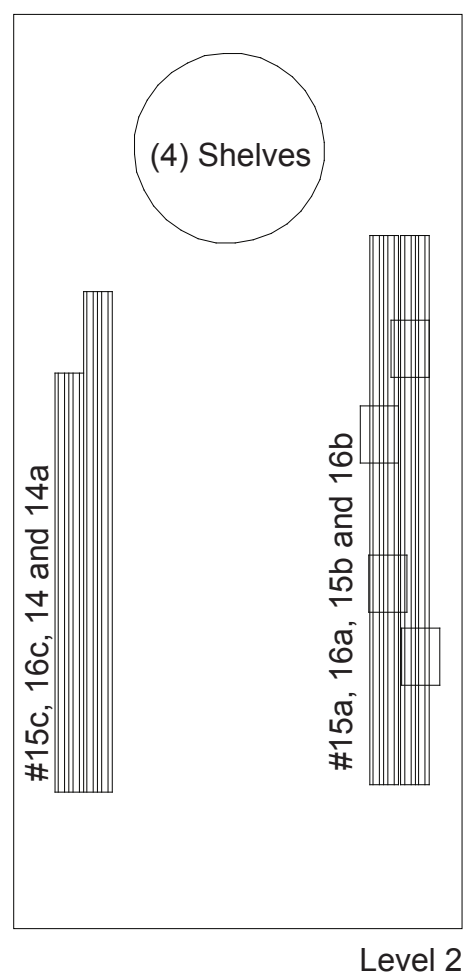
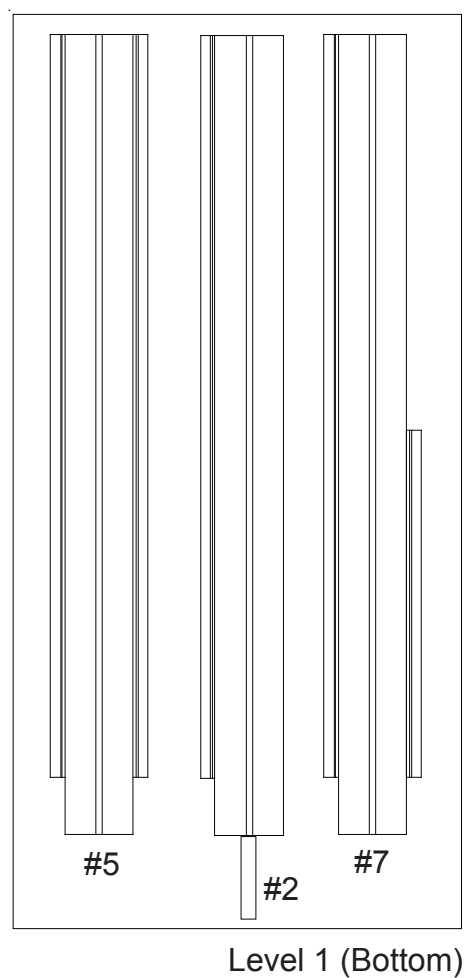

WHEN DISASSEMBLING ALUMINUM EXTRUSION, TIGHTEN ALL SETSCREWS AND LOCKS TO PREVENT LOSS DURING SHIPPING

Top View of each Level

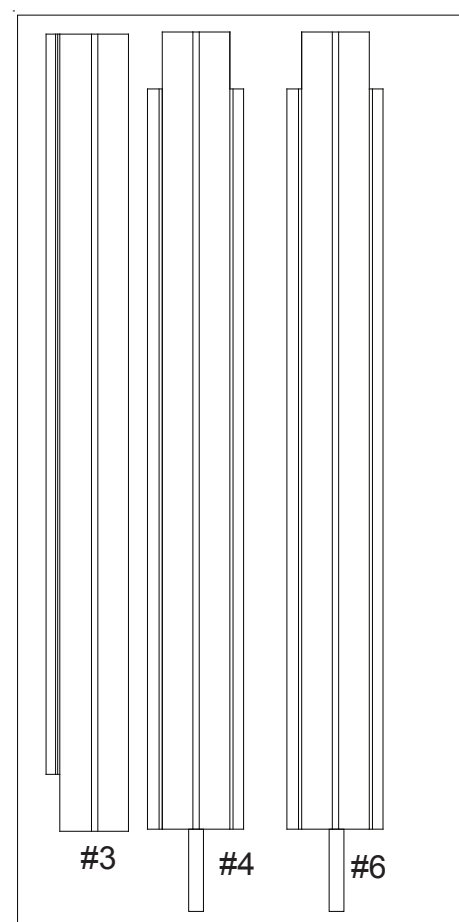

Level 1 (Bottom)

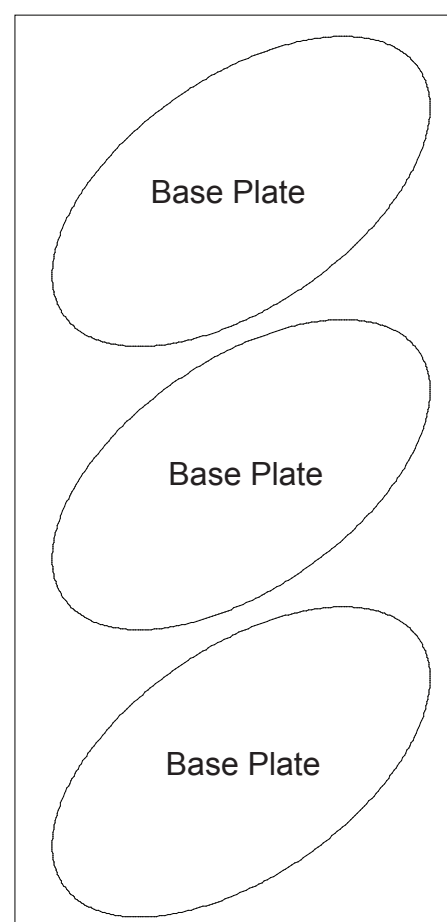

Level 2

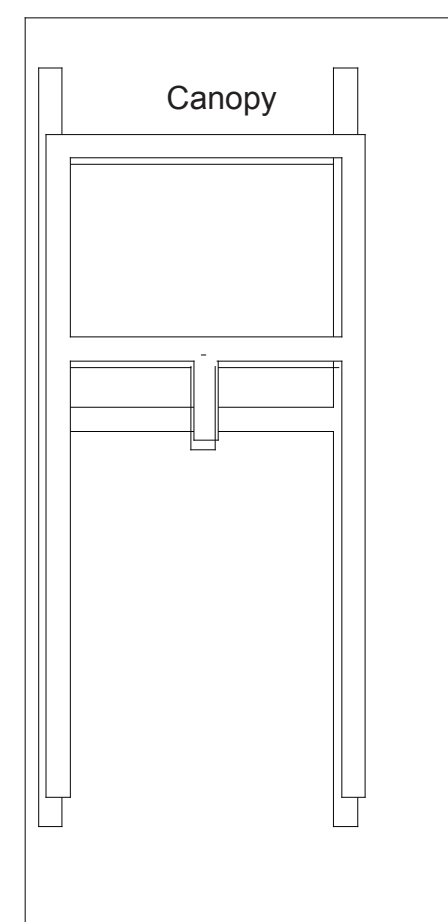

Slip Sheet

WHEN DISASSEMBLING ALUMINUM EXTRUSION, TIGHTEN ALL SETSCREWS AND LOCKS TO PREVENT LOSS DURING SHIPPING

Top View of each Level

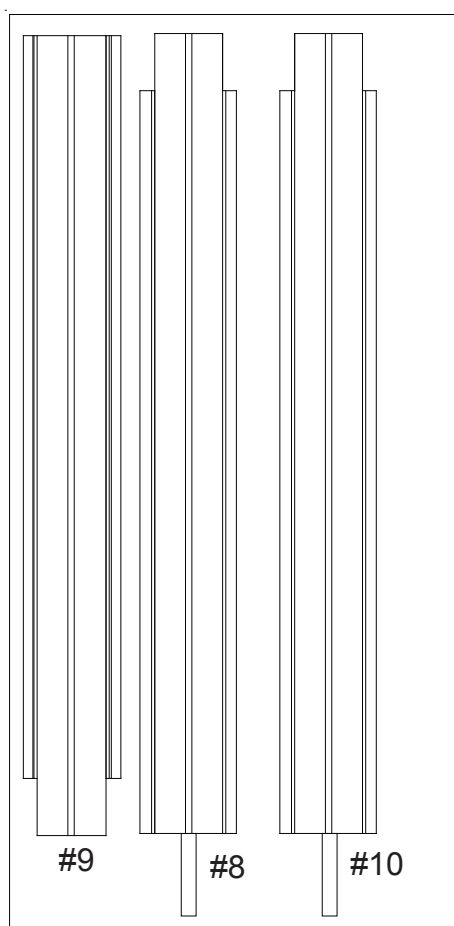

Level 1 (Bottom)

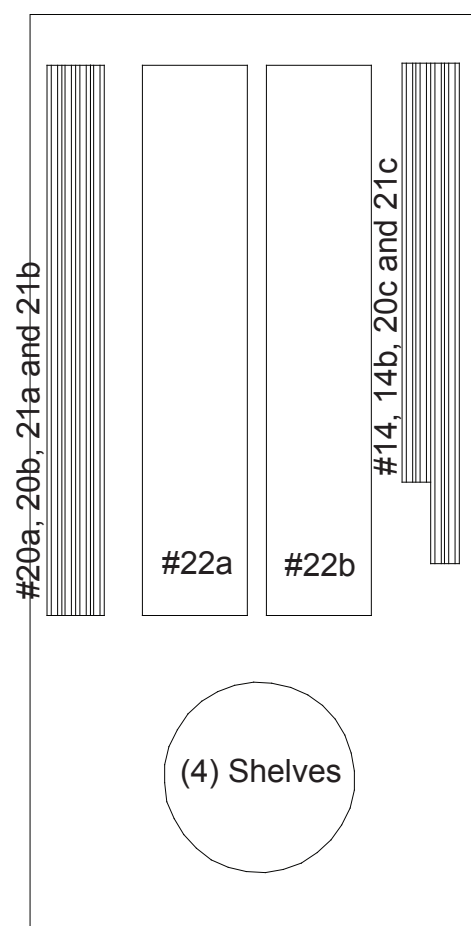

Level 2

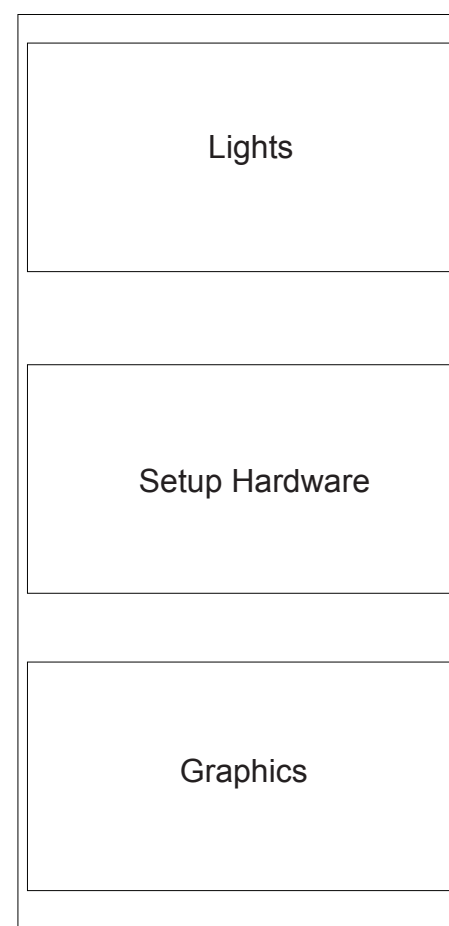

Slip Sheet

WHEN DISASSEMBLING ALUMINUM EXTRUSION, TIGHTEN ALL SETSCREWS AND LOCKS TO PREVENT LOSS DURING SHIPPING

Top View of each Level

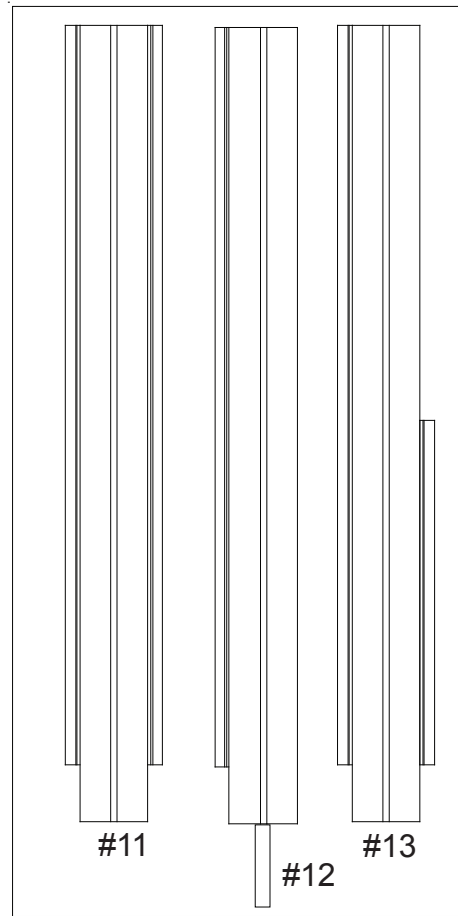

Level 1 (Bottom)

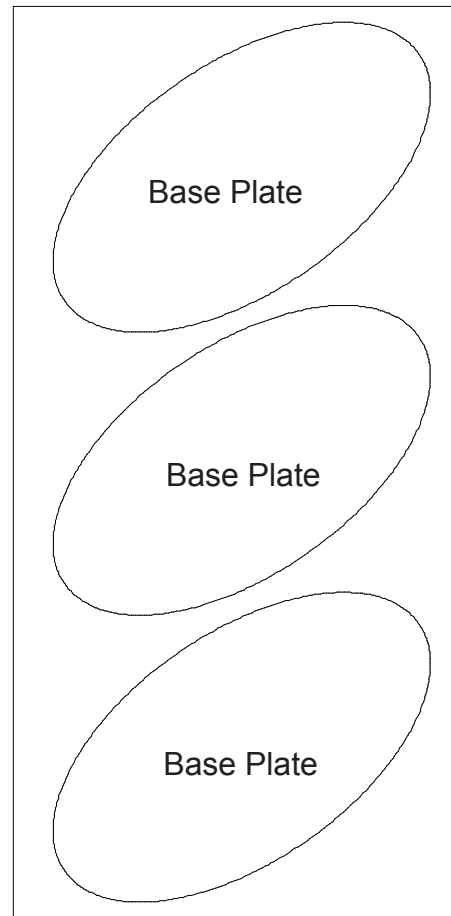

Level 2

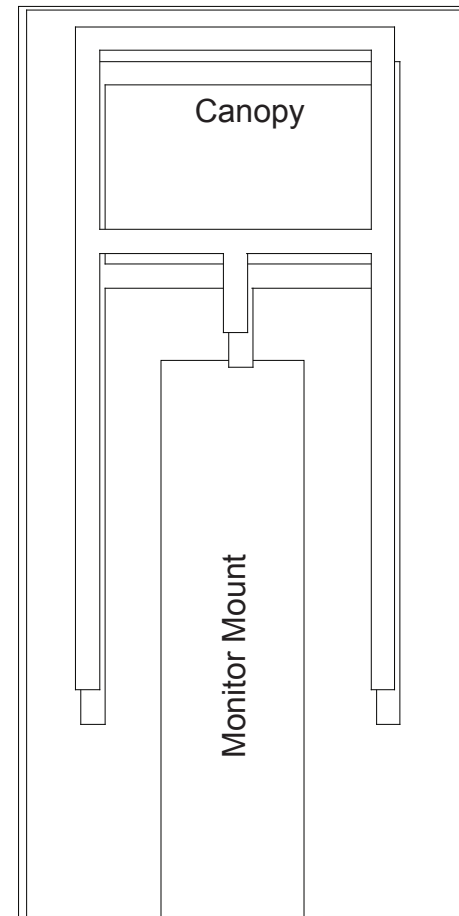

Slip Sheet

WHEN DISASSEMBLING ALUMINUM EXTRUSION, TIGHTEN ALL SETSCREWS AND LOCKS TO PREVENT LOSS DURING SHIPPING

Top View of each Level

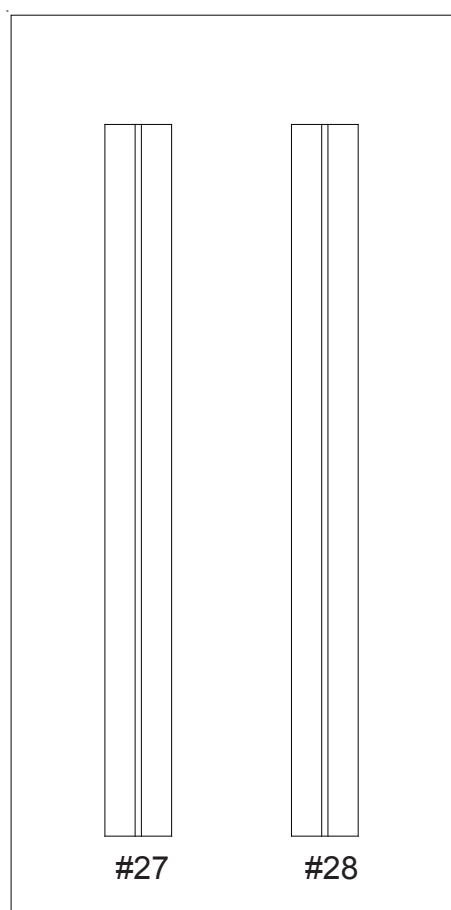

Level 1 (Bottom)

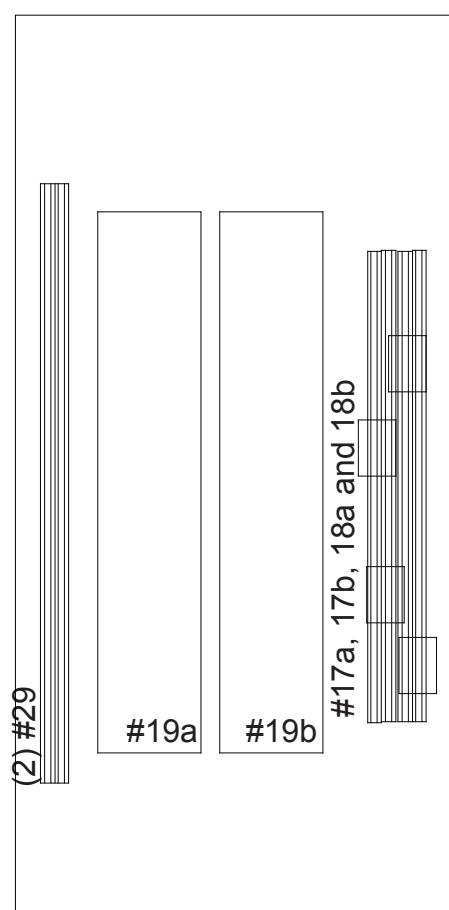

Level 2

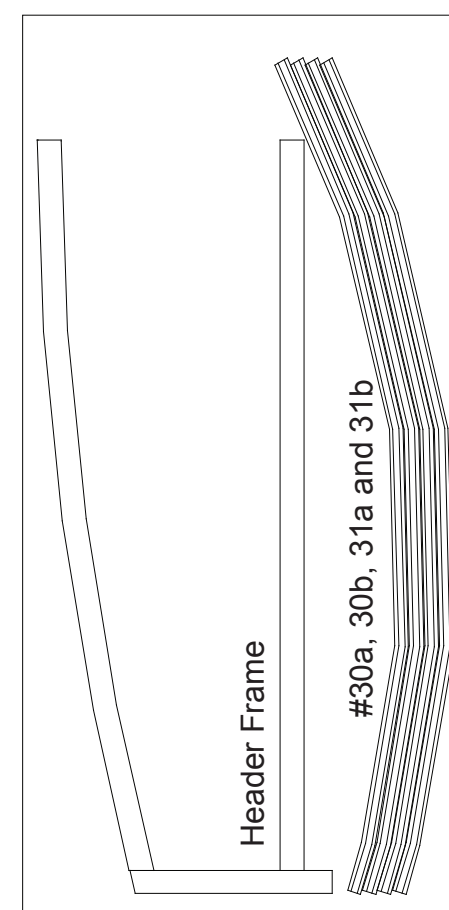

Level 3

WHEN DISASSEMBLING ALUMINUM EXTRUSION, TIGHTEN ALL SETSCREWS AND LOCKS TO PREVENT LOSS DURING SHIPPING