

WHEN DISASSEMBLING ALUMINUM EXTRUSION, TIGHTEN ALL SETSCREWS AND LOCKS TO PREVENT LOSS DURING SHIPPING

visionary™ IDESIGNS

Using Your Setup Instructions

The Visionary Designs Setup Instructions are created specifically for your configuration. They are laid out sequentially, including an exploded view of the entire display, and then a logical series of detailed steps to assemble the main structure and components. We encourage you to study the instructions **before** attempting to assemble your exhibit.

Each page reminds you to tighten the setscrews after disassembling your exhibit to prevent loss of the locks and setscrews (see below in RED). This is **VERY IMPORTANT**.

Cleaning and Packing Your Display

- 1) Use care when cleaning aluminum extrusion or acrylic inserts. Use only non-abrasive cleaners.
- 2) When cleaning laminate inserts or countertops, use mild cleansers and a soft material such as cotton.
- 3) Keep all display components away from extreme heat and long exposure to sunlight to avoid warping and fading.
- 4) Retain all packing material. It will make re-packing much easier and will reduce the likelihood of shipping damage.



The Tool

Most Visionary Designs exhibits can be assembled with the supplied Hex Key Tool. Occasionally, a flat head screwdriver may be required.



Typical Connection

Most horizontal extrusion connections have a patented expandable lock. This lock inserts into the groove of an opposing extrusion. Tightening the lock with the Hex Key Tool expands the lock and creates a strong positive connection.



Typical Connection (cont'd)



Detail B

Numbered Label

Each extrusion contains a numbered label which corresponds with setup instructions. The label is located within a groove of the extrusion (when possible). With Visionary Designs the labels contain Black numbers unless otherwise specified.



Detail C

Horizontal Inline Connection (remove only one setscrew)

Remove only (1) setscrew when disassembling. Replace setscrew in extrusion after assembling it. Before packing, replace setscrew in extrusion to avoid losing it.

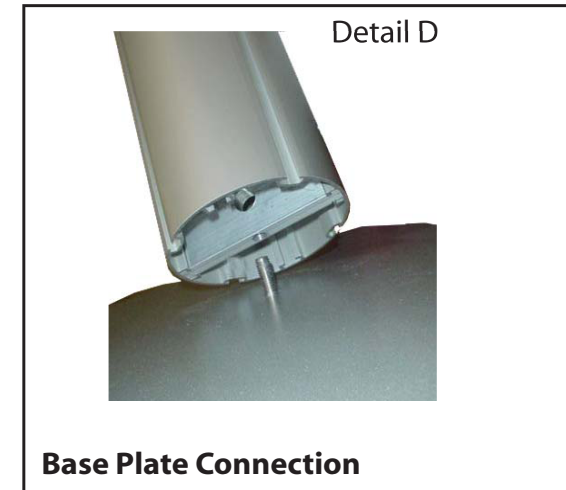

Detail D

Base Plate Connection

Attach base plate to round or square vertical extrusion using the bolt provided. Be careful not to strip the threads.

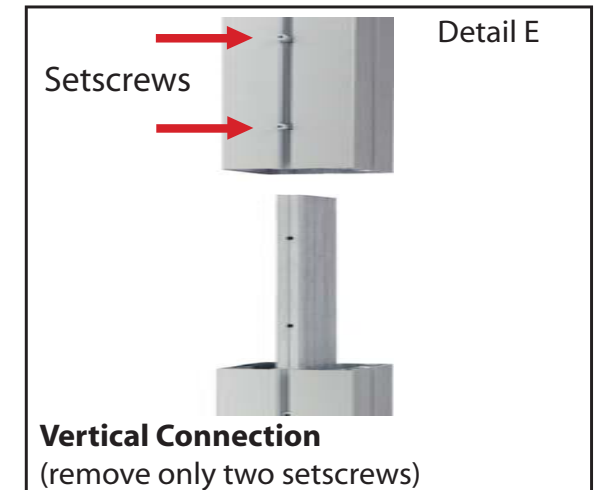

Detail E

Vertical Connection
(remove only two setscrews)

When vertical extrusions are packed in portable cases rather than crates or tubs, they must be broken down into smaller sections which then require assembly.

Remove only (2) setscrews when disassembling. Replace setscrews in extrusion after assembling it. Before packing, replace setscrews in extrusion to avoid losing them.

WHEN DISASSEMBLING ALUMINUM EXTRUSION, TIGHTEN ALL SETSCREWS AND LOCKS TO PREVENT LOSS DURING SHIPPING

Item	Qty.	Description
1	3	Oval Base Plate
2	2	42" Lower Square Vertical Extrusion
3	1	42" Upper Square Vertical Extrusion w/ Canopy Attachment
4	1	42" Upper Square Vertical Extrusion
5	1	42" Lower Round Vertical Extrusion
6	1	42" Upper Round Vertical Extrusion w/ Canopy Attachment
7	2	28" Horizontal Extrusion
8A/8B	1/1	26" Horizontal Extrusion
9A/9B	1/1	26" Horizontal Extrusion

Steps:

- 1) Attach lower vertical extrusions [5] to oval base plate [1].
- 2) Attach upper vertical extrusions [3, 4 and 6] atop lower vertical extrusions [2 and 5]
- 3) Connect horizontal extrusions [9A to 9B and 10A to 10B] together.
- 4) Attach horizontal extrusions [7, 8A/8B and 9A/9B] between vertical extrusions [2/3, 2/4 and 5/6] as shown.
- 5) Apply graphics to assembled backwall, see Attaching Graphic details.

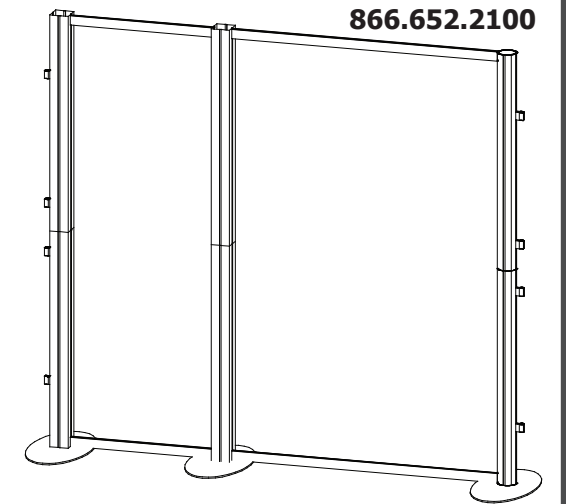

****L-Extrusions are highlighted in GREEN****
 L-Extrusions must stay attached to extrusions when shipping.

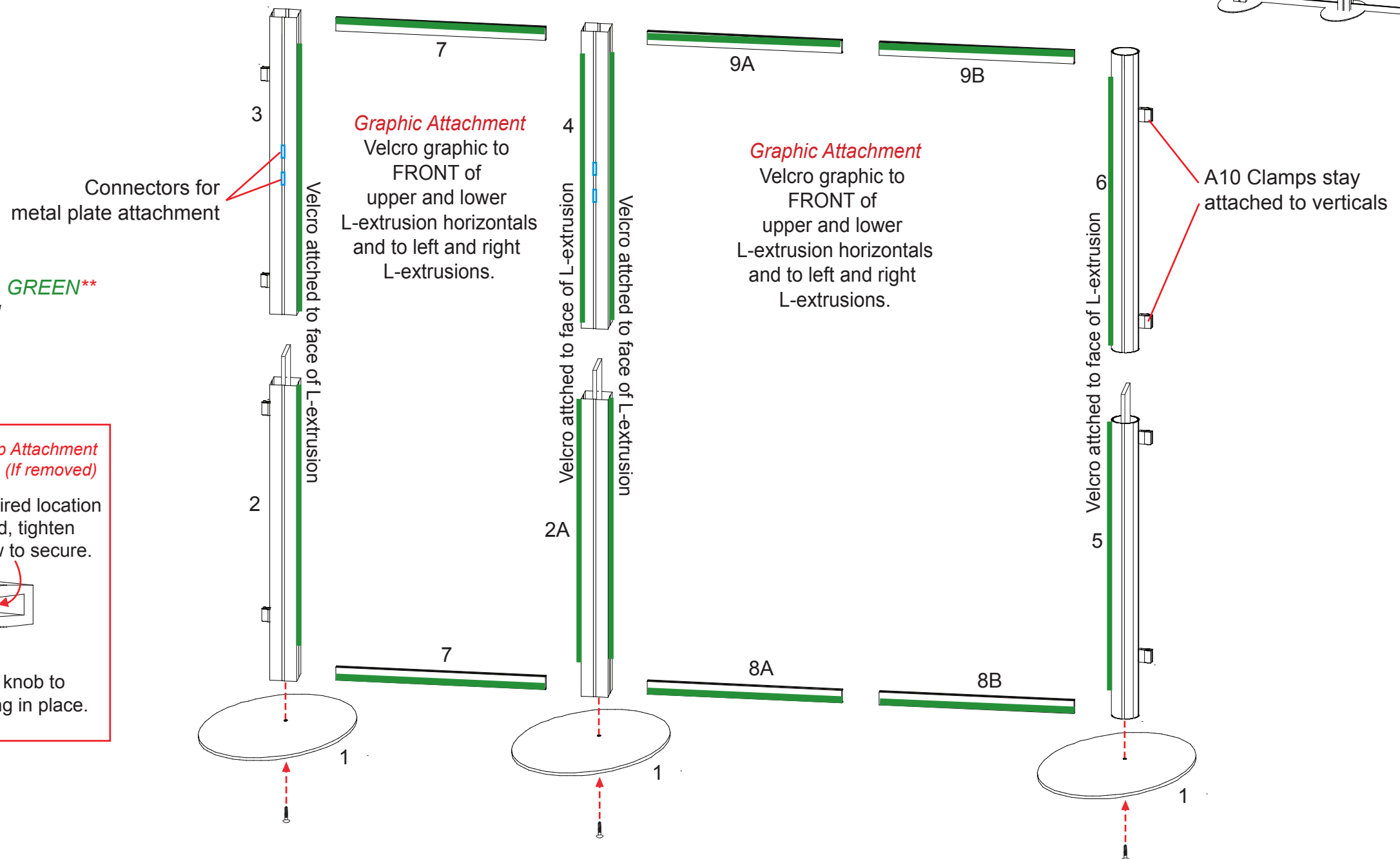
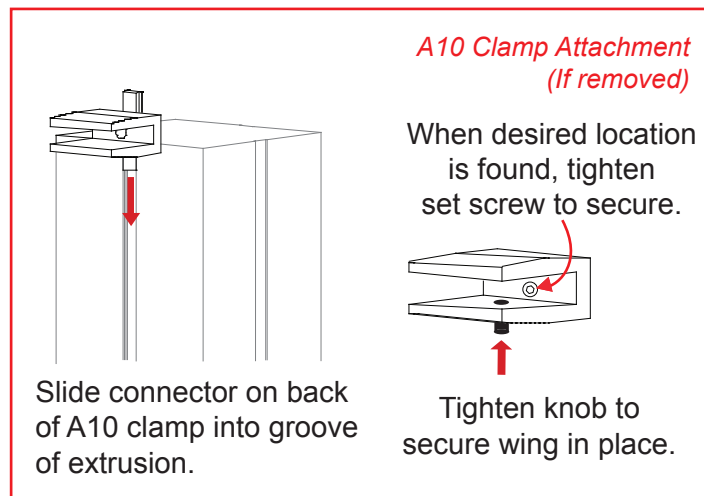

WHEN DISASSEMBLING ALUMINUM EXTRUSION, TIGHTEN ALL SETSCREWS AND LOCKS TO PREVENT LOSS DURING SHIPPING

866.652.2100

Item	Qty.	Description
10	1	5.862" w Vertical Extrusion
11	1	5.862" w Vertical Extrusion
12a/12b	1/1	39" w Horizontal Extrusion
13a/13b	1/1	40.319" w Formed Horizontal Extrusion

Steps

- 1) Attach round sign to assembled backwall as shown.
- 2) Assemble ceiling pieces together using bolts and wing nuts.
- 3) Assemble header pieces together as shown, then apply graphic to back of assembled header.
- 4) Attach assembled ceiling to top of assembled backwall.
- 5) Attach header to top of ceiling and secure with bolts and wing nuts.
- 6) Attach wings and literature shelves to backwall where indicated.

*****Velcro side must face to back for graphic attachment***
 Each half of header frame must stay assembled when shipping**

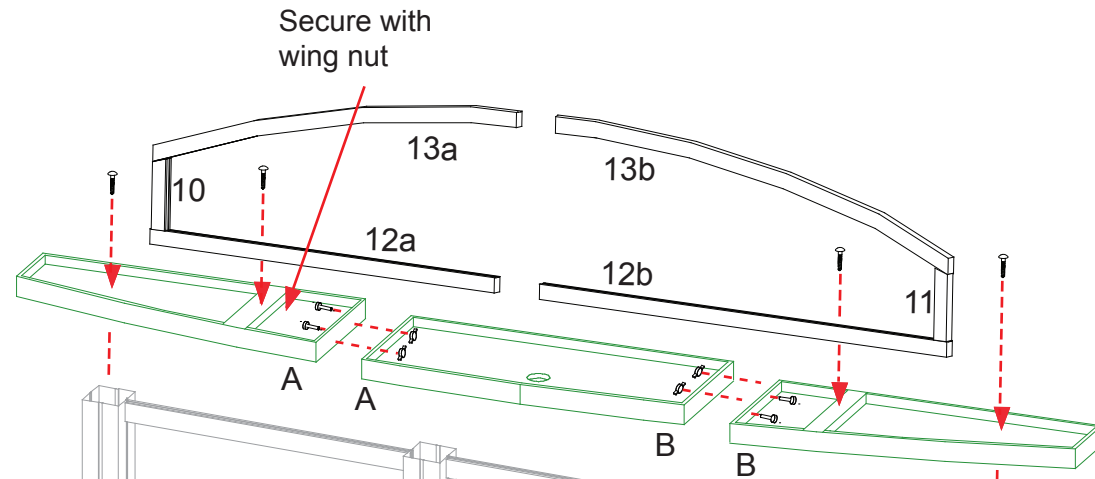

Example of Canopy Connection

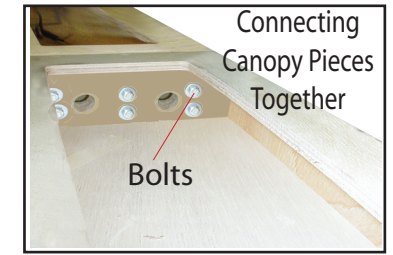

Connect 3 piece Canopy together by using bolts and wing nuts provided.

Graphic Attachment

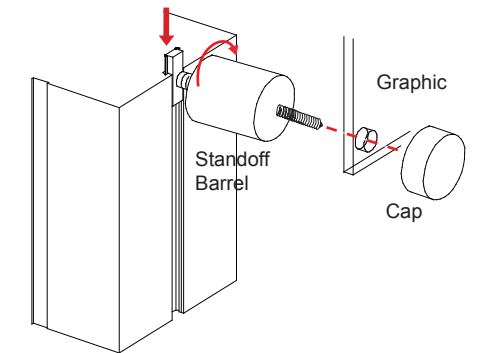

Slide connector on back of stand-off barrels into groove of extrusion and twist to secure in place. Secure graphic to standoffs using screw caps.

Literature Rack Attachment

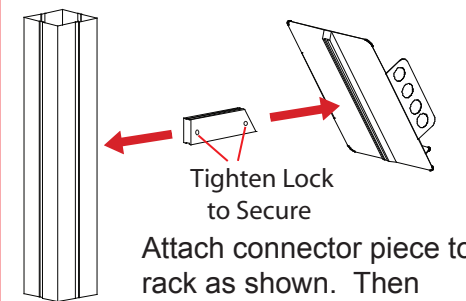

Tighten Lock to Secure
 Attach connector piece to rack as shown. Then connect assembled literature rack to vertical extrusion.

Monitor Mount Attachment

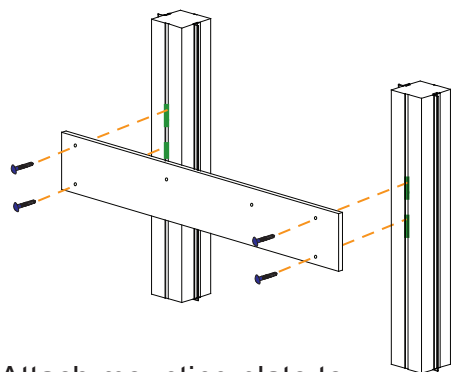

Attach mounting plate to connectors on verticals using bolts

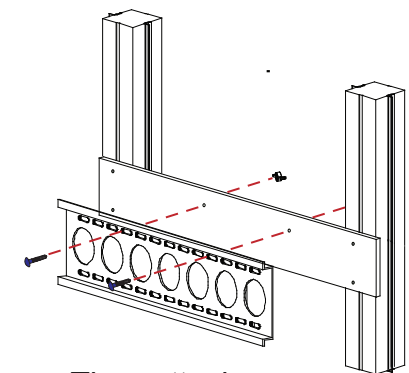

Then attach wall plate to plate using bolts and wing nuts

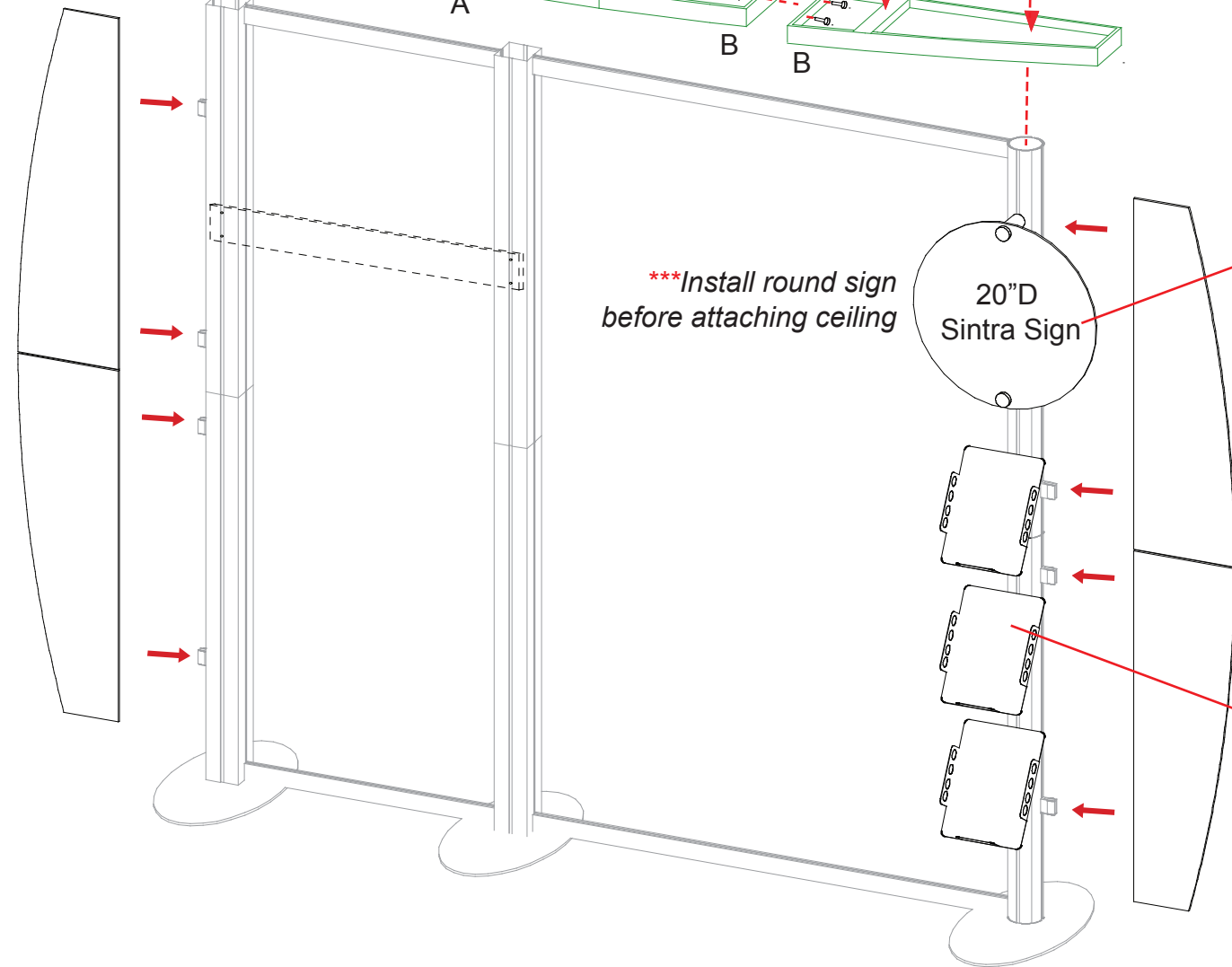

*****Install round sign before attaching ceiling*****

20" D Sintra Sign

WHEN DISASSEMBLING ALUMINUM EXTRUSION, TIGHTEN ALL SETSCREWS AND LOCKS TO PREVENT LOSS DURING SHIPPING

866.652.2100

Item	Qty.	Description
14	1	18"D Round Base Plate
15	1	40"h Lower Round Vertical Extrusion
16	1	40"h Upper Round Vertical Extrusion
17	1	36"h Round Vertical Extrusion

Steps

- 1) Attach vertical extrusions [15 and 16] to base plate [14] as shown.
- 2) Attach upper vertical extrusion [17] atop vertical extrusion [16].
- 3) Attach tapered plex wing to front of vertical extrusion [15] using standoff caps and 16"D round sintra sign to vertical extrusion [17].
- 3) Place and attach counter atop vertical extrusion [15] and secure with thumbscrews as shown.

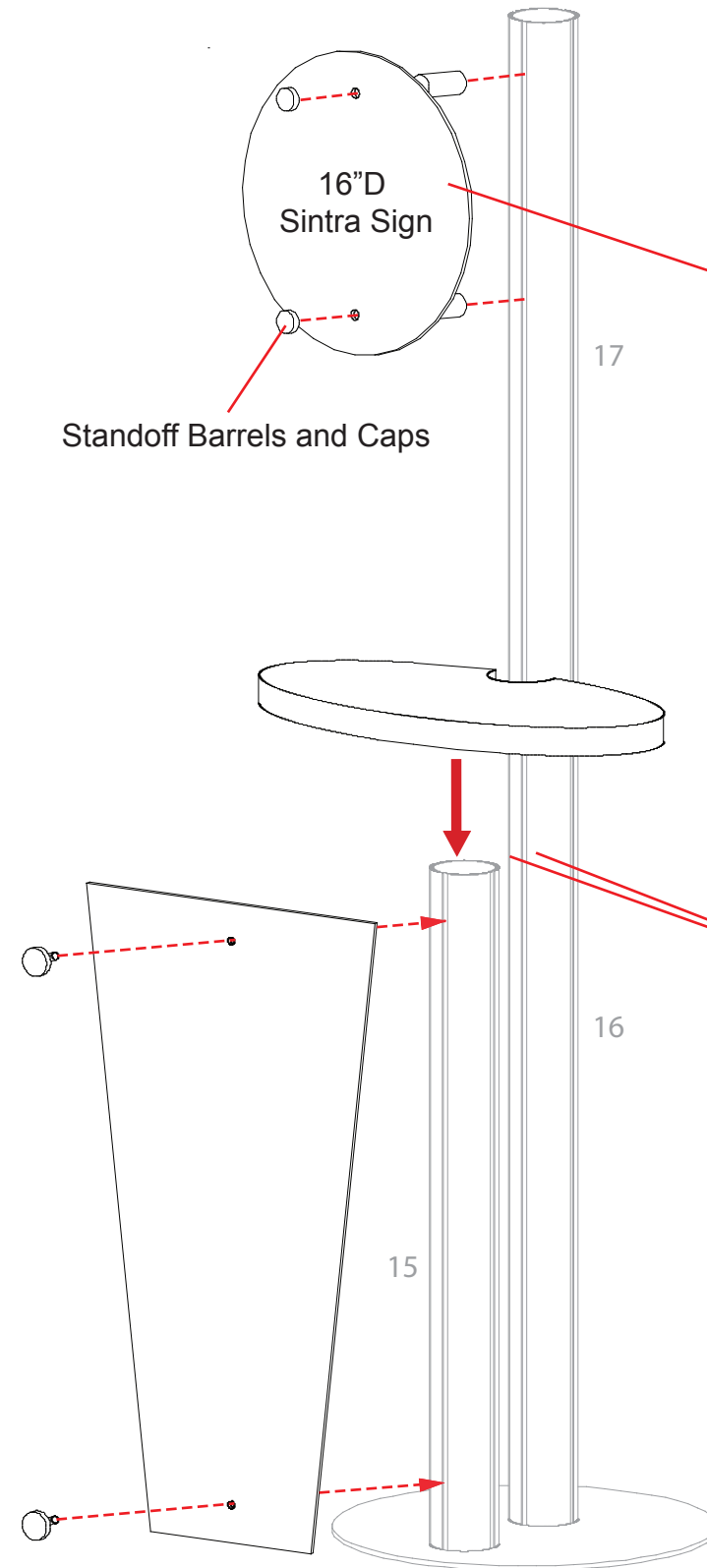
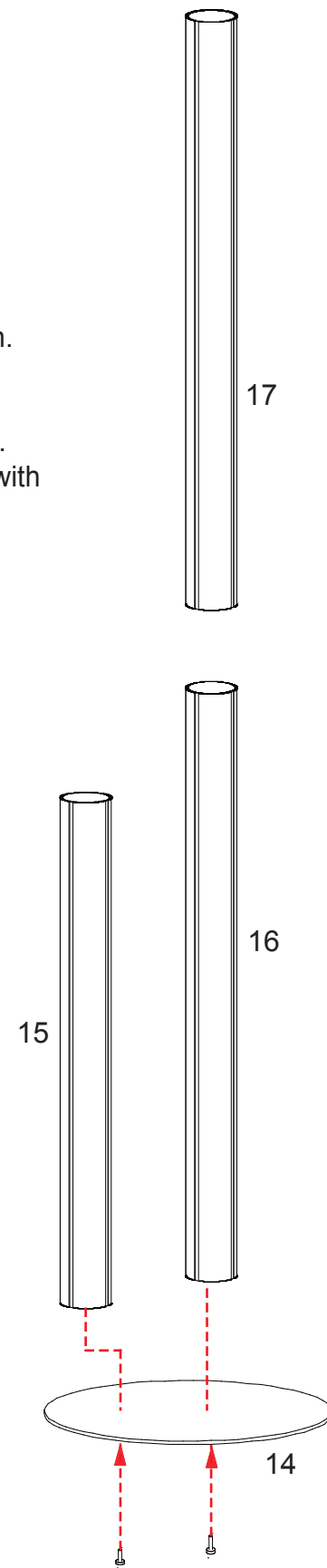
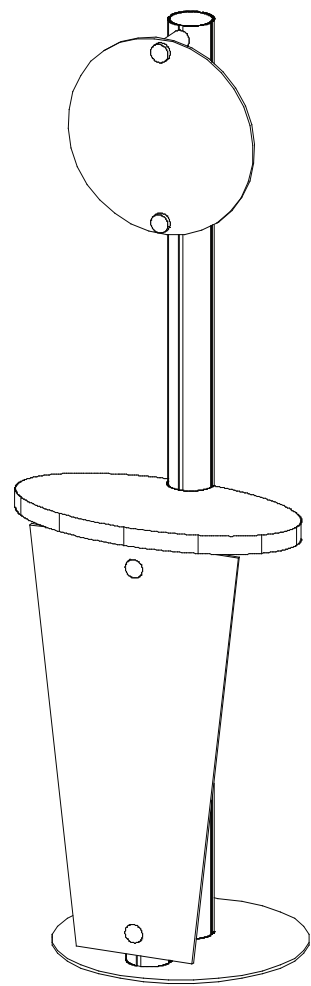

Graphic Attachment

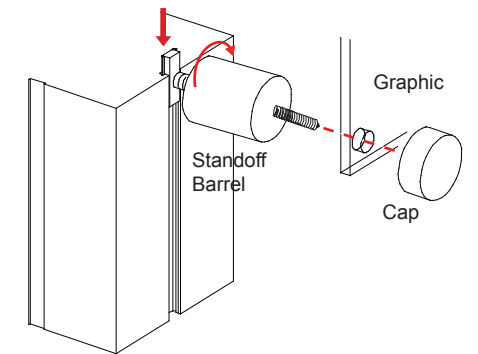

Slide connector on back of standoff barrels into groove of extrusion and twist to secure in place. Secure graphic to standoffs using screw caps.

*** Thumbscrew Attachment**

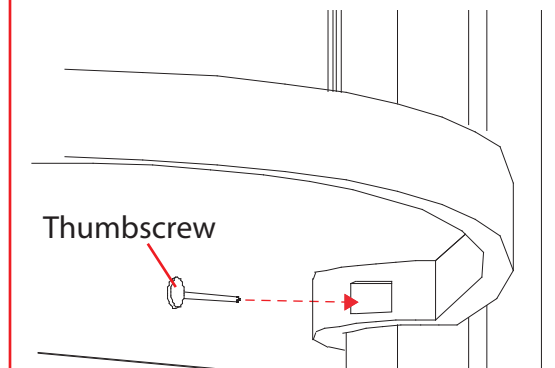

After setting counter on horizontal support, then secure counter to vertical extrusion as shown.

WHEN DISASSEMBLING ALUMINUM EXTRUSION, TIGHTEN ALL SETSCREWS AND LOCKS TO PREVENT LOSS DURING SHIPPING

Top View of each Level

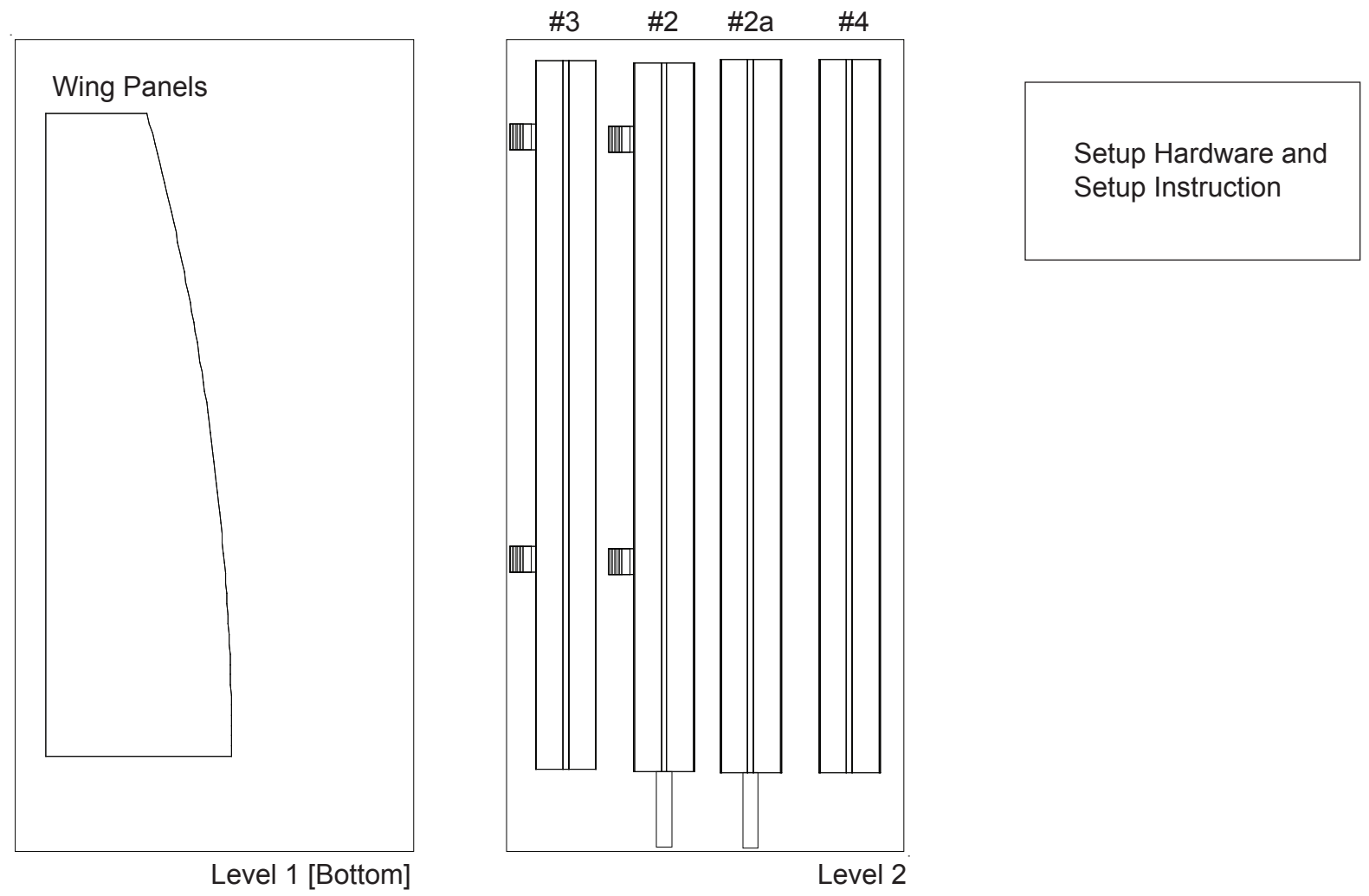

WHEN DISASSEMBLING ALUMINUM EXTRUSION, TIGHTEN ALL SETSCREWS AND LOCKS TO PREVENT LOSS DURING SHIPPING

Top View of each Level

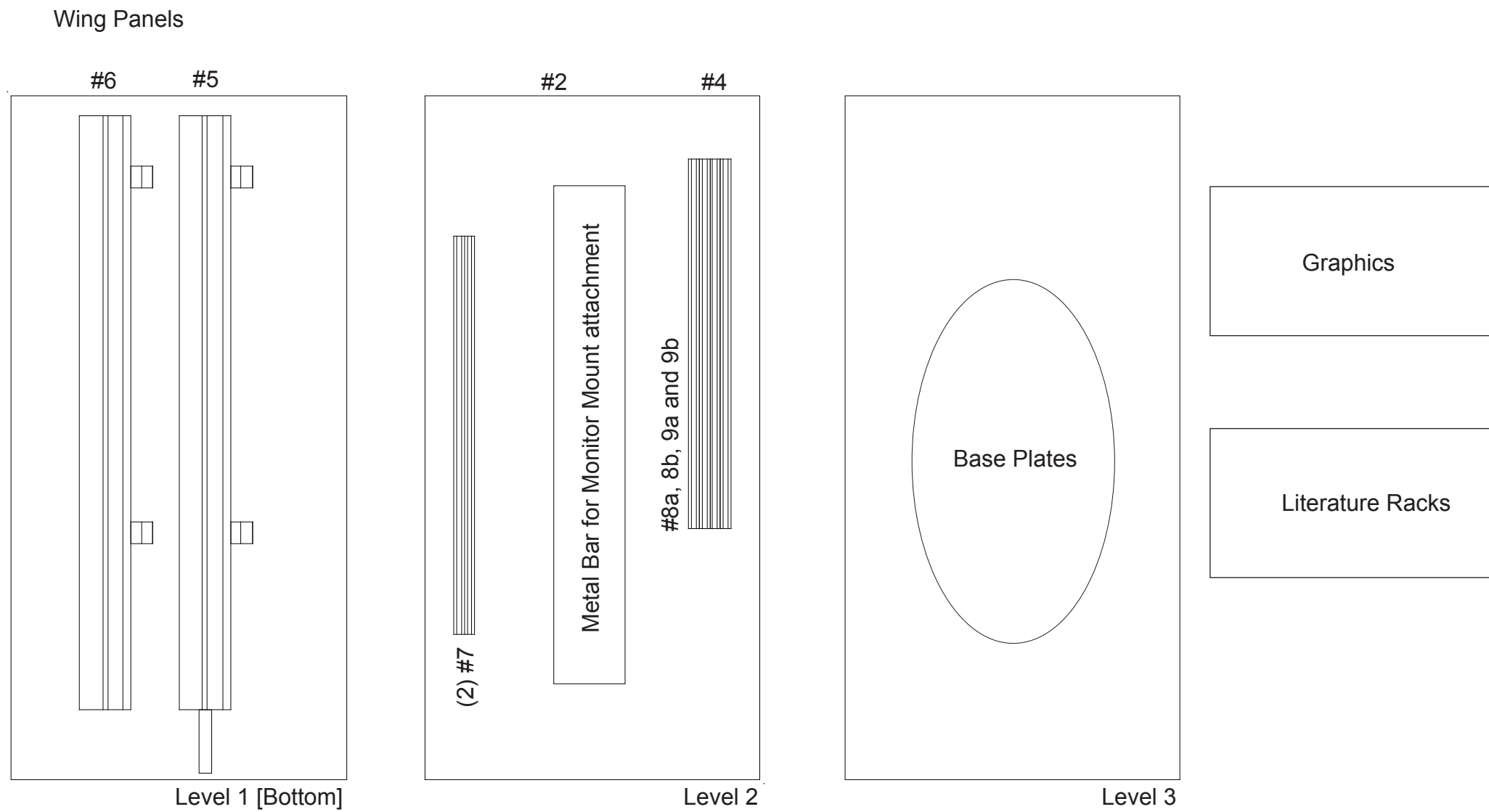

WHEN DISASSEMBLING ALUMINUM EXTRUSION, TIGHTEN ALL SETSCREWS AND LOCKS TO PREVENT LOSS DURING SHIPPING

Top View of each Level

Header Frame Assemblies

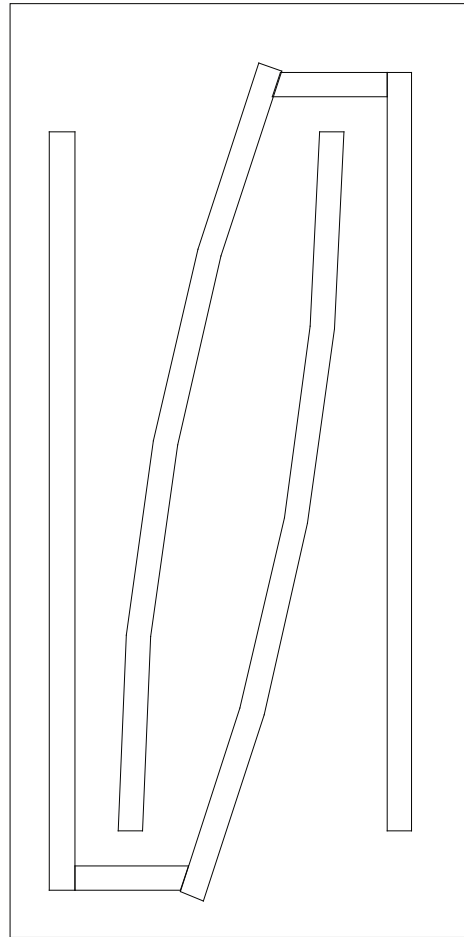

Level 1 [Bottom]

Ceiling Pieces

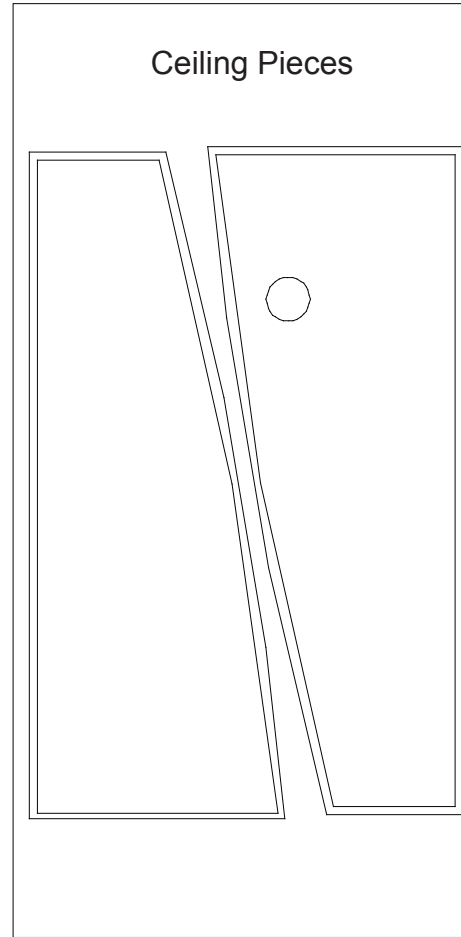

Level 2

Ceiling Piece

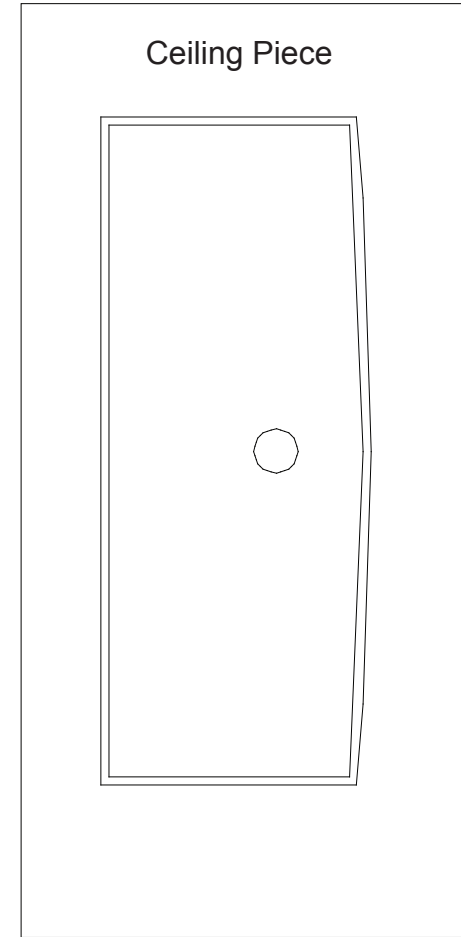

Level 3

WHEN DISASSEMBLING ALUMINUM EXTRUSION, TIGHTEN ALL SETSCREWS AND LOCKS TO PREVENT LOSS DURING SHIPPING

Top View of each Level

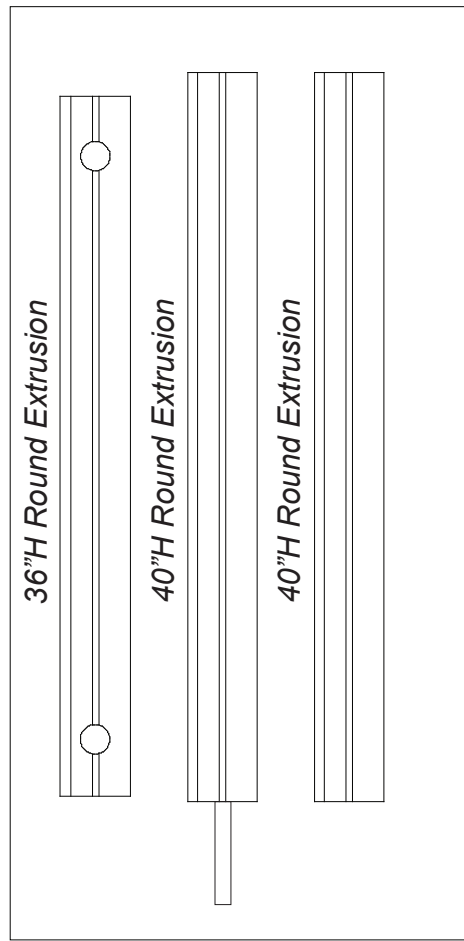

Level 1 [Bottom]

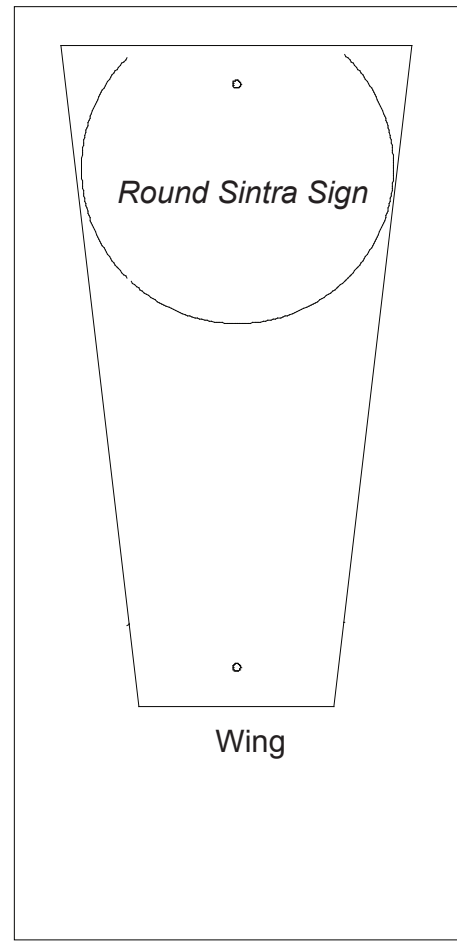

Level 2

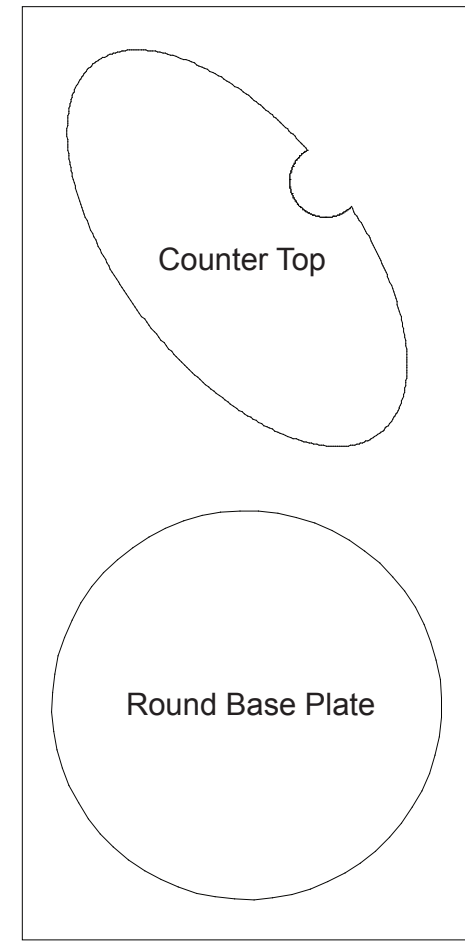

Level 3

WHEN DISASSEMBLING ALUMINUM EXTRUSION, TIGHTEN ALL SETSCREWS AND LOCKS TO PREVENT LOSS DURING SHIPPING