

# euro It | *HYBRIDS*

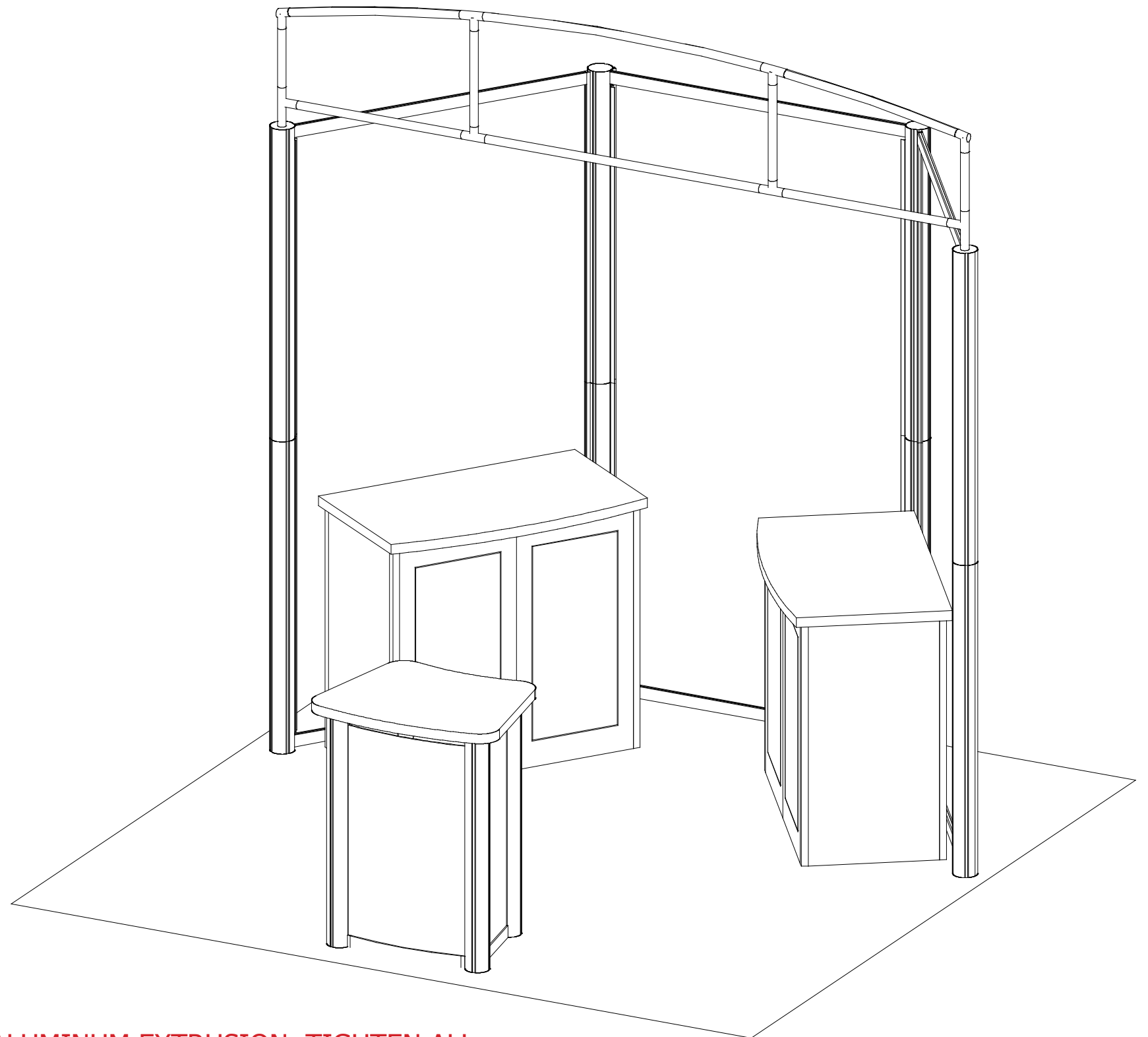

**WHEN DISASSEMBLING ALUMINUM EXTRUSION, TIGHTEN ALL SETSCREWS AND LOCKS TO PREVENT LOSS DURING SHIPPING**

# euro It | HYBRIDS

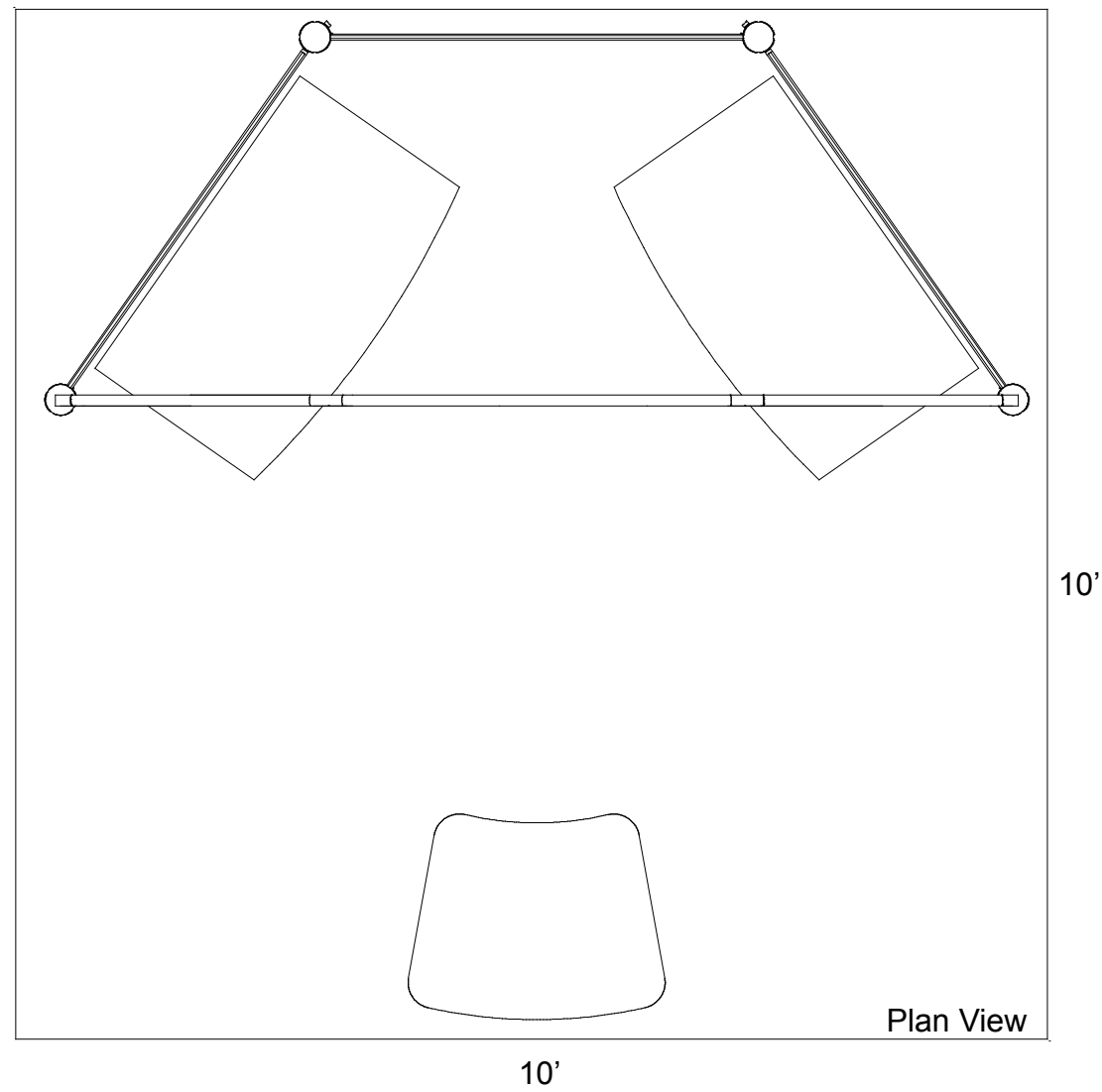
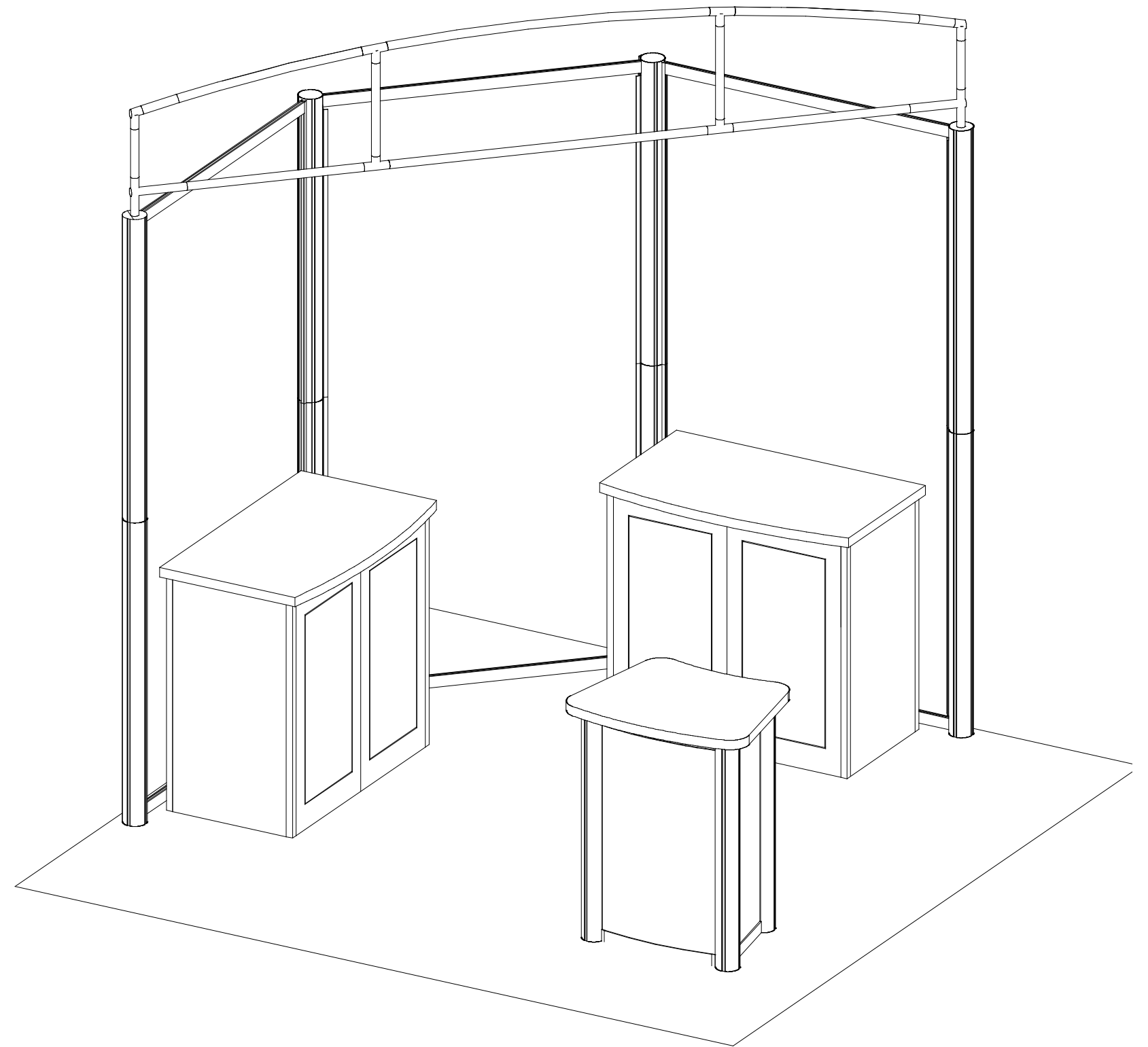
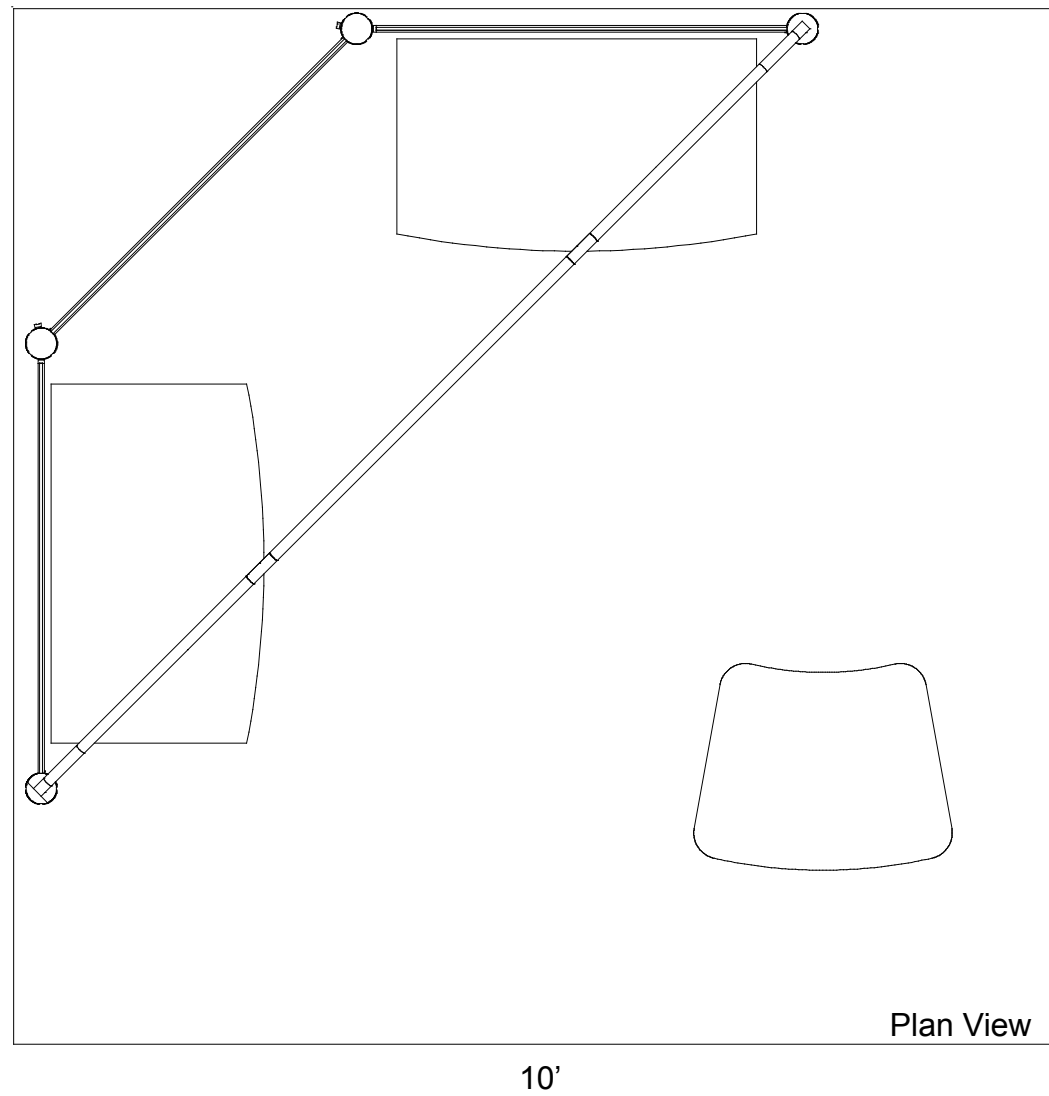

WHEN DISASSEMBLING ALUMINUM EXTRUSION, TIGHTEN ALL SETSCREWS AND LOCKS TO PREVENT LOSS DURING SHIPPING

# euro lt | HYBRIDS

## Using Your Setup Instructions

The Euro LT Hybrids Setup Instructions are created specifically for your configuration. They are laid out sequentially in levels, including exploded views, and a logical series of detailed steps to assemble the main structure and components. We encourage you to study the instructions **before** attempting to assemble your exhibit.

Each page reminds you to tighten the setscrews after disassembling your exhibit to prevent loss of the locks and setscrews (see below in RED). This is VERY IMPORTANT.

## Cleaning and Packing Your Display

- 1) Use care when cleaning aluminum extrusion or acrylic inserts. Use only non-abrasive cleaners.
- 2) When cleaning laminate inserts, countertops, or panels use mild cleansers and a soft material such as cotton.
- 3) Keep all display components away from extreme heat and long exposure to sunlight to avoid warping and fading.
- 4) Retain all packing material. It will make re-packing much easier and will reduce the likelihood of shipping damage.

## General Setup Instructions for Extrusion System



Most exhibits can be assembled with the supplied Hex Key Tool. Occasionally, a flat head screwdriver may be required.



Most horizontal extrusion connections have a patented expandable lock. This lock inserts into the groove of an opposing extrusion. Tightening the lock with the Hex Key Tool expands the lock and creates a strong positive connection.

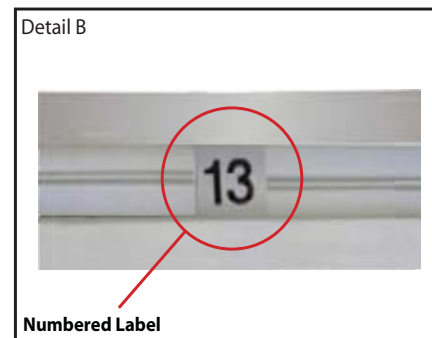

Each extrusion contains a numbered label which corresponds with setup instructions. The label is located within a groove of the extrusion (when possible). With extrusion components the labels contain Black numbers unless otherwise specified.

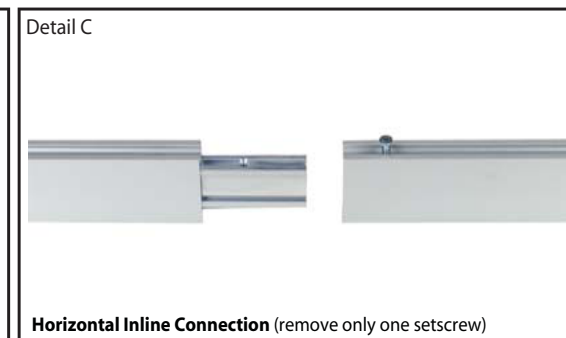

Remove only (1) setscrew when disassembling. Replace setscrew in extrusion after assembling it. Before packing, replace setscrew in extrusion to avoid losing it.

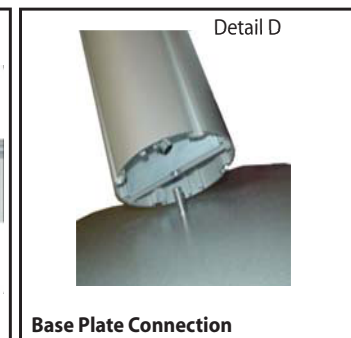

Attach base plate to round or square vertical extrusion using the bolt provided. Be careful not to strip the threads.

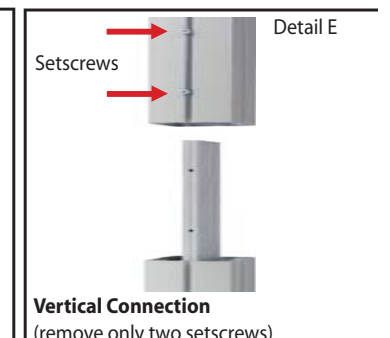

When vertical extrusions are packed in portable cases rather than crates or tubs, they must be broken down into smaller section which then require assembly.

Remove only (2) setscrews when disassembling. Replace setscrews in extrusion after assembling it. Before packing, replace setscrews in extrusion to avoid losing them.

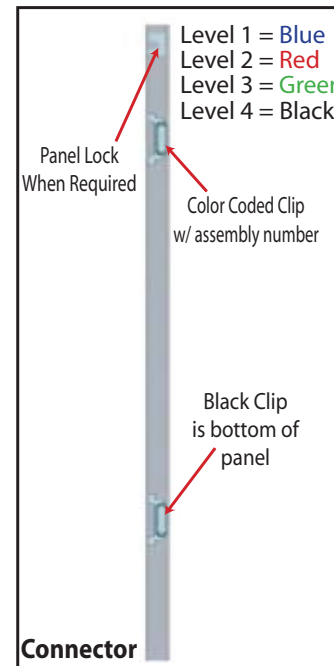

Each component has 2 clips, the lower clip is ALWAYS black. The top clip is color coded to distinguish which level. The color coded clip also contains the numbered label.

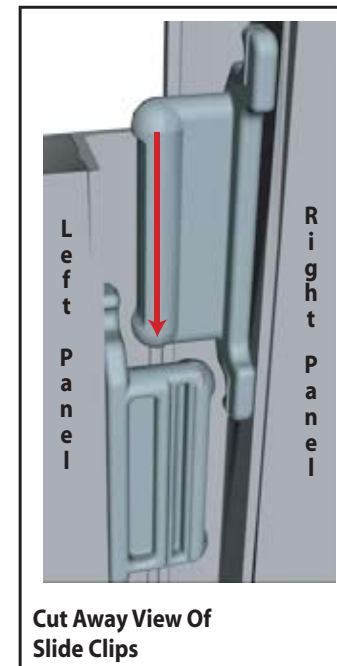

Components connect together by aligning them and sliding downward connecting clips together.

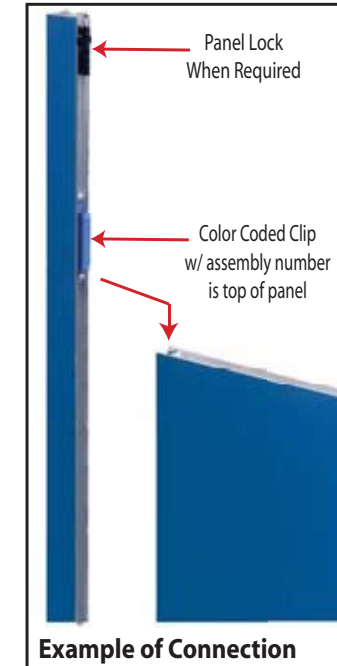

Configurations are assembled from left to right, usually starting with #1 and following the numbered sequence.

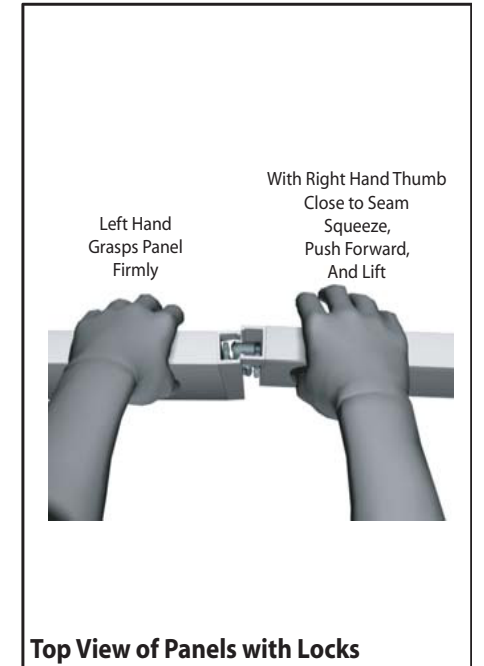

The first level of components contain panel locks that are located at the top of the panel for extra stability and seamless connection. When disassembling panels twist top connection slightly and lift right panel upward.

**WHEN DISASSEMBLING ALUMINUM EXTRUSION, TIGHTEN ALL SETSCREWS AND LOCKS TO PREVENT LOSS DURING SHIPPING**

Part Number	Qty	Description
1	1	48"h Lower Vertical extrusion
2	1	48"h Upper Vertical extrusion
3	1	48"h Lower Vertical extrusion
4	1	48"h Upper Vertical extrusion
7	1	48"h Lower Vertical extrusion
8	1	48"h Upper Vertical extrusion
9	1	48"h Lower Vertical extrusion
10	1	48"h Upper Vertical extrusion
11	4	47.488" Horizontal w/ Velcro
12	4	48" Horizontal w/ Velcro

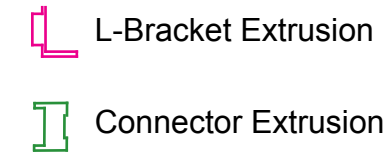

- Steps
- 1) Connect vertical extrusions [1 to 2, 3 to 4, 5 to 6, 7 to 8, and 9 to 11] together.
  - 2) Connect horizontal extrusions [11 and 12] between vertical assemblies as shown.

**Note: Attaching Graphics**

Attach Backwall Graphics to Velcro by wrapping the Graphic over the Top of the Upper Horizontals and under the Bottom of the Lower Horizontals Then securing to Velcro down the sides.

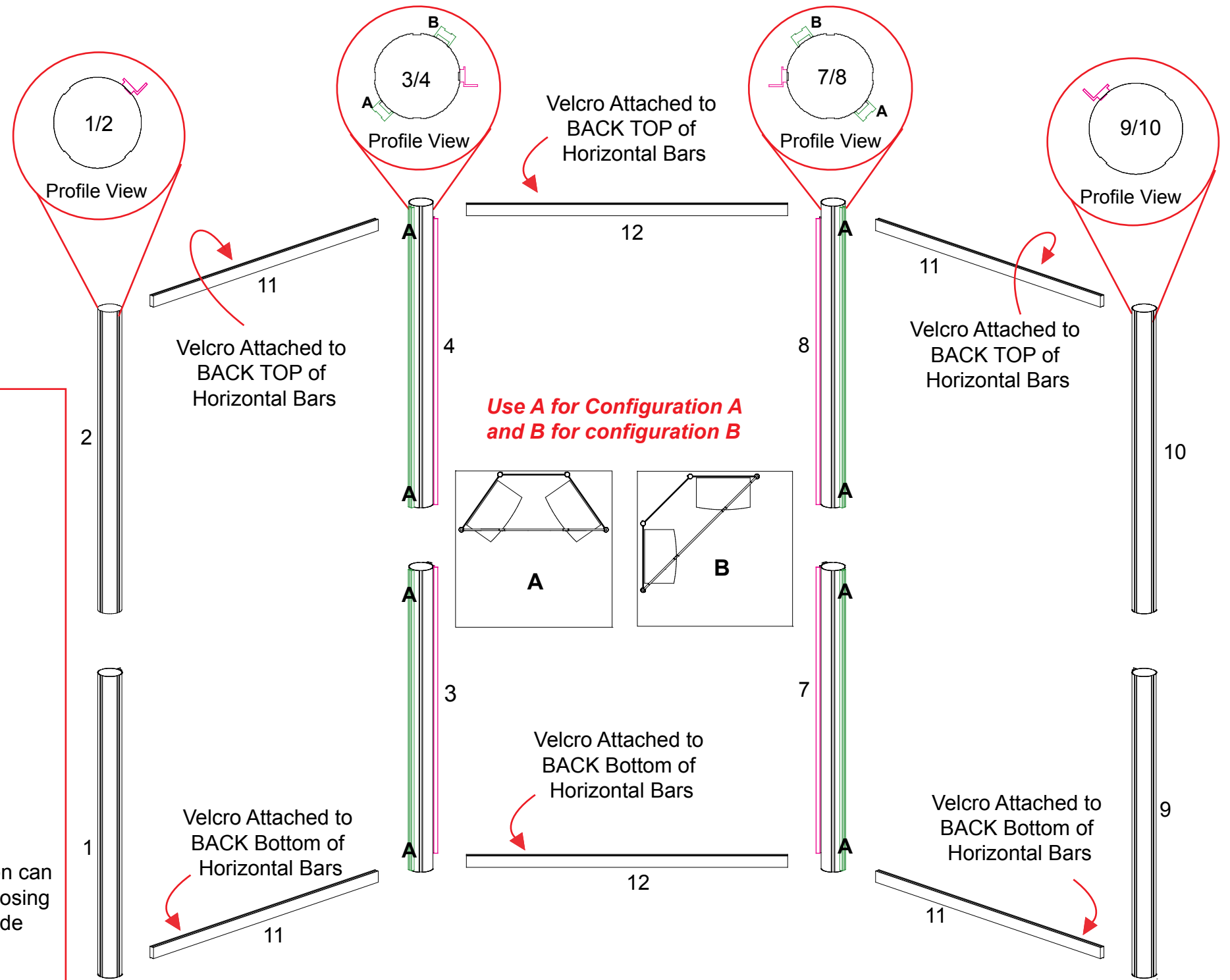
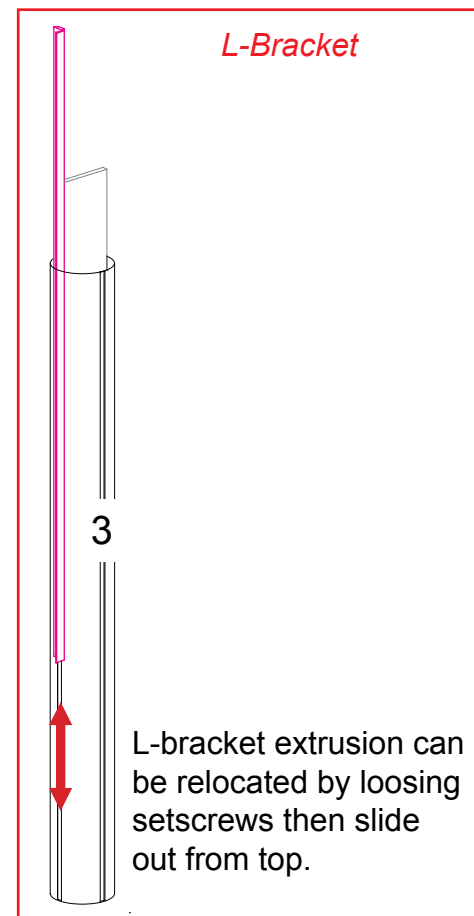
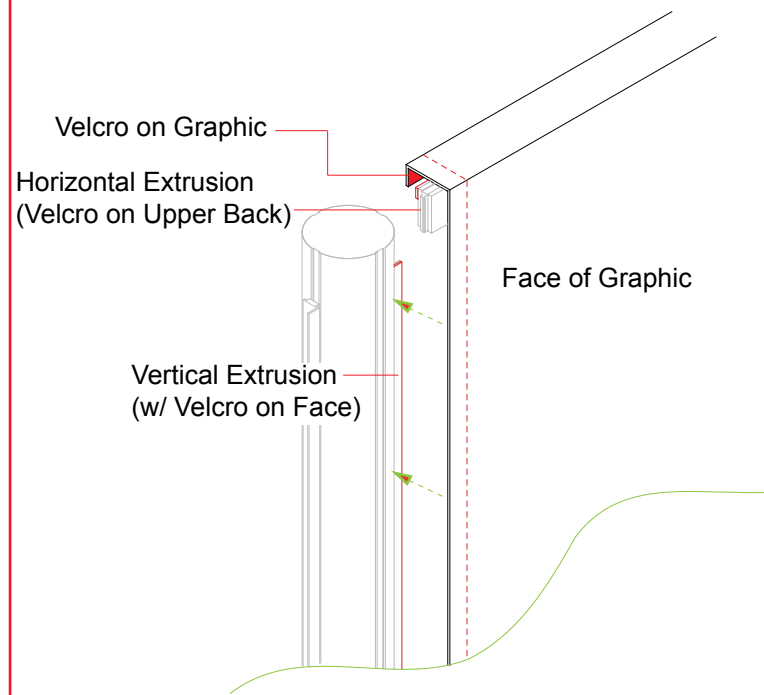

**WHEN DISASSEMBLING ALUMINUM EXTRUSION, TIGHTEN ALL SETSCREWS AND LOCKS TO PREVENT LOSS DURING SHIPPING**

# AERO

## Using Your Setup Instructions

The Aero Overhead Sign Setup Instructions are created specifically for your configuration. They include an exploded view of the frame which is sequentially numbered. We encourage you to study the instructions before attempting to assemble your exhibit.

Connections are kept very simple: no tools. Everything assembles with push-button connectors and pre-connected horizontal sections.

## Cleaning and Packing Your Display

- 1) Use care when cleaning aluminum extrusion or acrylic inserts. Use only non-abrasive cleaners.
- 2) Retain all packing material. It will make re-packing much easier and will reduce the likelihood of shipping damage.

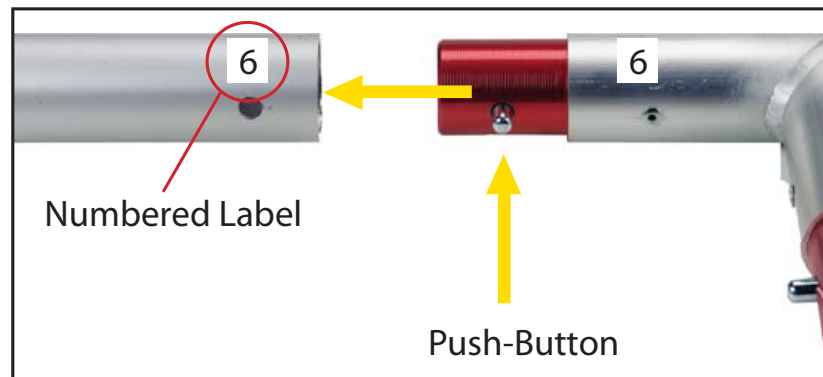
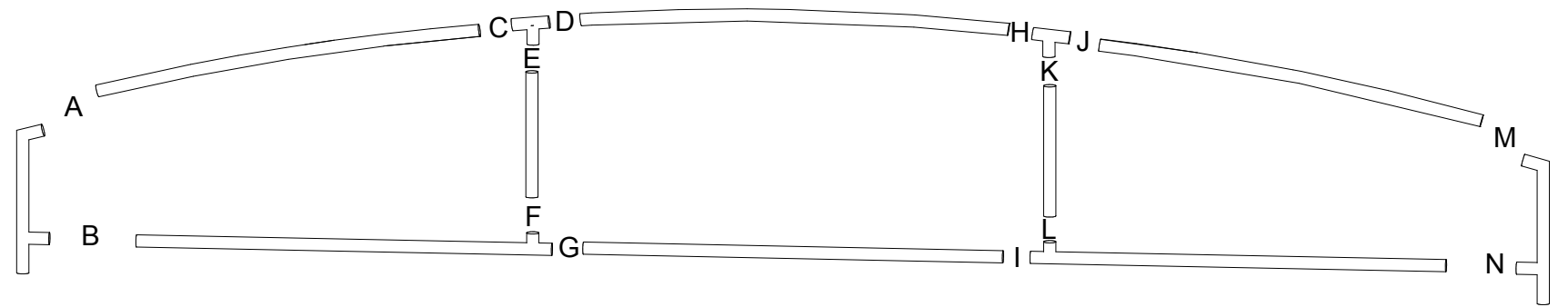

Connections are made by holding the button down and sliding the red tube into opposing tube until the connection is made. To disassemble push button and pull or twist extrusions apart.

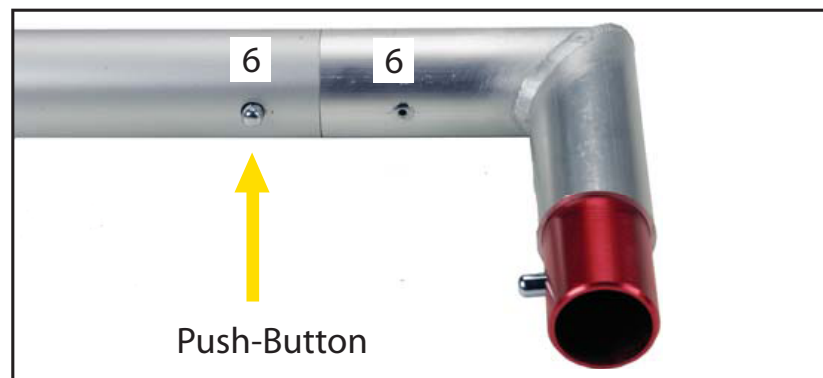

### Configuration A

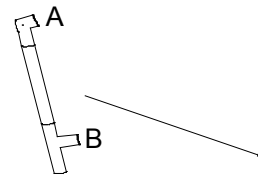

### Configuration B

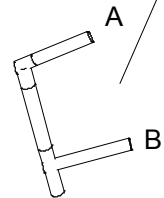

**Use shorter end pieces for Configuration A**  
**Use longer end pieces for configuration B**

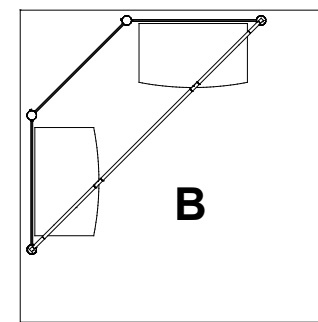
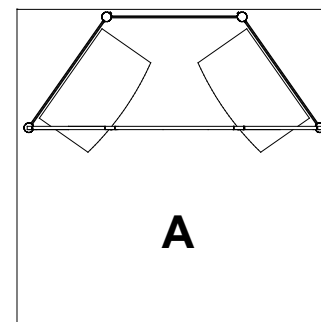

Assemble frame as shown.  
 Then place atop assembled backwall.

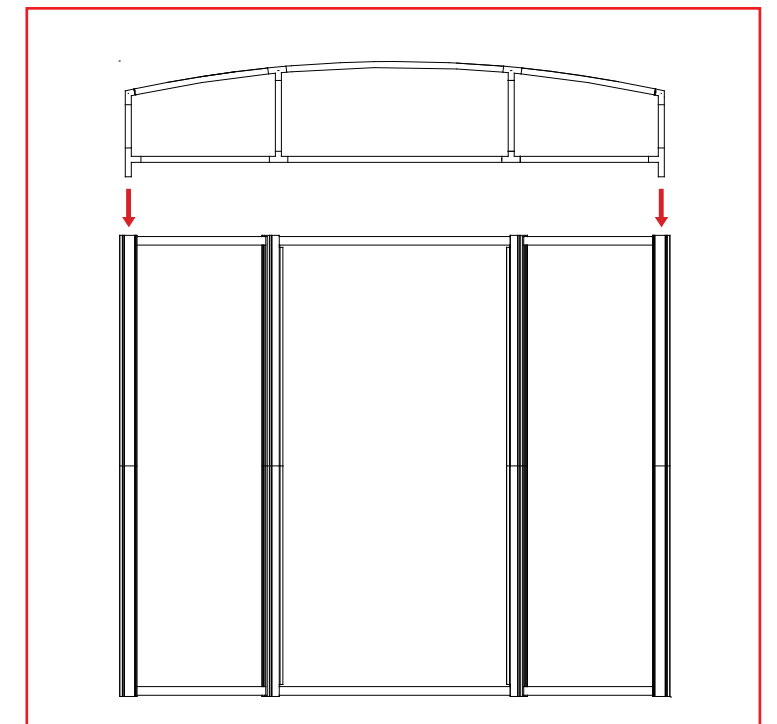

**WHEN DISASSEMBLING ALUMINUM EXTRUSION, TIGHTEN ALL SETSCREWS AND LOCKS TO PREVENT LOSS DURING SHIPPING**

866.652.2100

Repeat for Both Pedestals

Item Number	Description
1	19" w x 38" h Flat Panel
2	19" w x 38" h Flat Panel
3	38" h 90° Connector
4	19" w x 38" h Flat Panel
5	38" h 90° Connector
6	19" w x 38" h Flat Panel w/Door
7	19" w x 38" h Flat Panel w/Door
8	38" h 90° Connector
9	19" w x 38" h Flat Panel
10	38" h 90° Connector

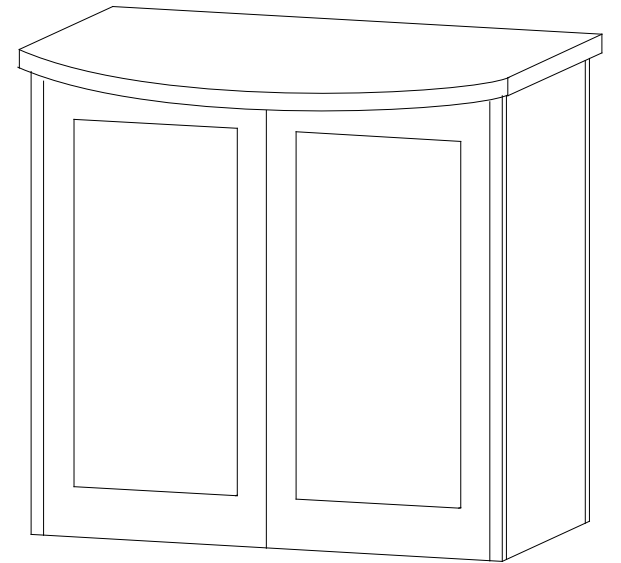

Steps:  
Connect panels together in numerical order as shown in illustrations.

Set counter atop assembled pedestal.

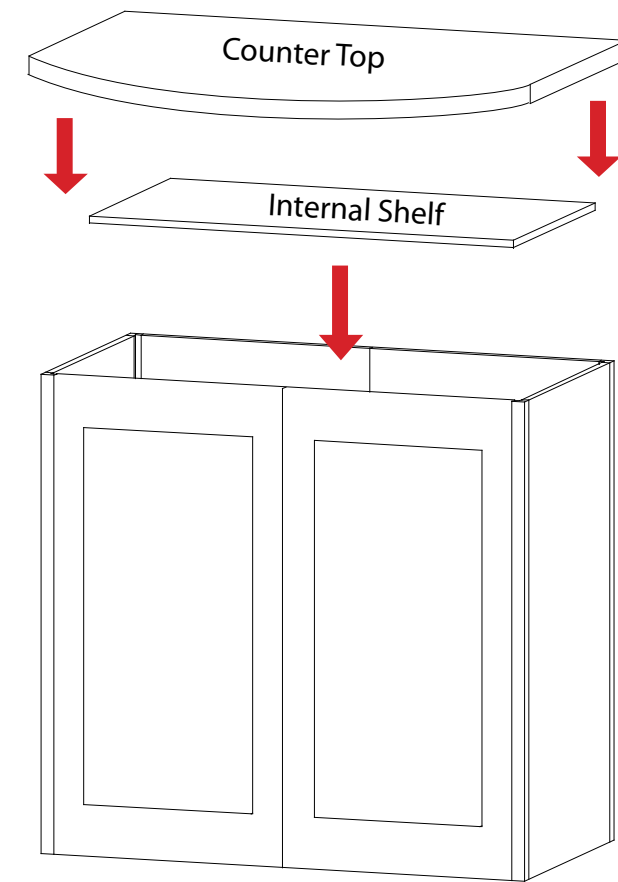
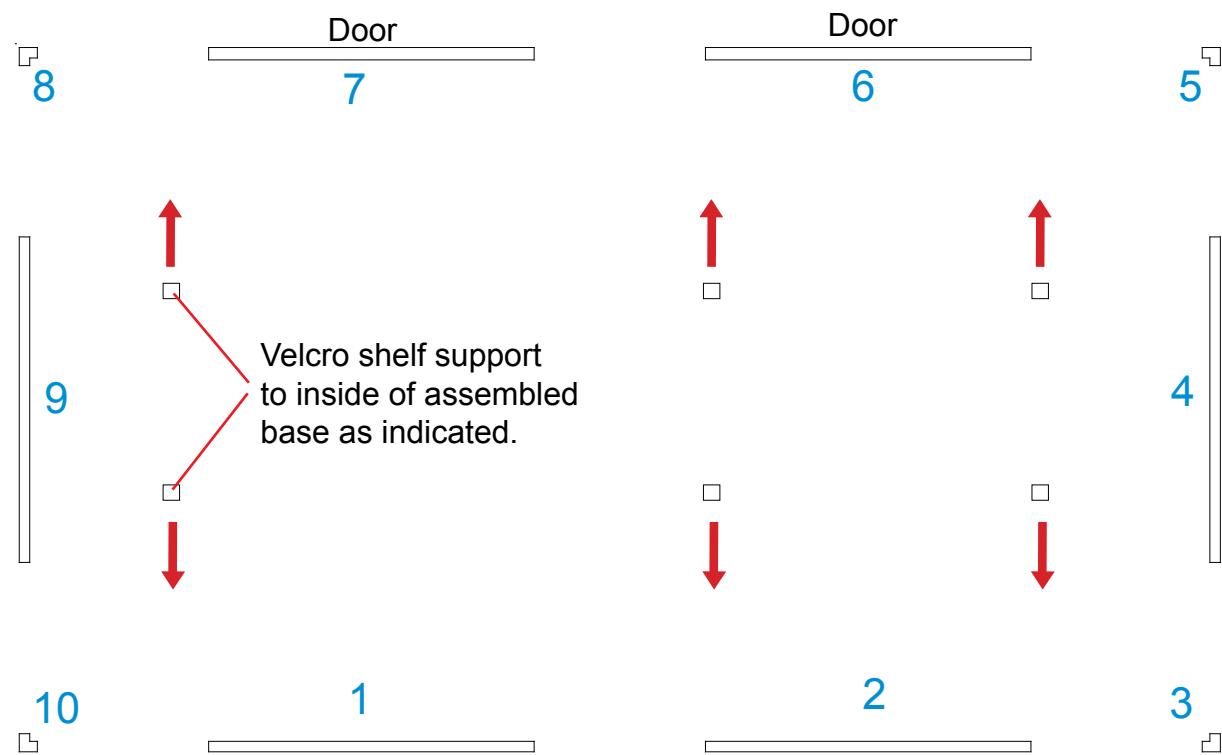

**WHEN DISASSEMBLING ALUMINUM EXTRUSION, TIGHTEN ALL SETSCREWS AND LOCKS TO PREVENT LOSS DURING SHIPPING**

866.652.2100

Item	Qty.	Description
13	1	38" h Vertical Extrusion
14	1	38" h Vertical Extrusion w/ Door Hinges
15	1	38" h Vertical Extrusion w/ Door Stop
16	1	38" h Vertical Extrusion
17	4	11.81" w Horizontal Extrusion
18	2	12.156" w Horizontal Extrusion
19	2	18.06" w Curved Horizontal Extrusion

Steps:

- 1) Attach lower horizontal extrusions [17, 18 and 19] between vertical extrusions [13, 14, 15 and 16].
- 2) Place inserts and door between vertical extrusions as shown.
- 3) Attach upper horizontal extrusions [17, 18 and 19] between vertical extrusions [13, 14, 15 and 16] and atop inserts and door.
- 4) Velcro shelf supports to inside of assembled base.
- 5) Place internal shelf atop supports.
- 6) Set counter top on assembled pedestal as shown.

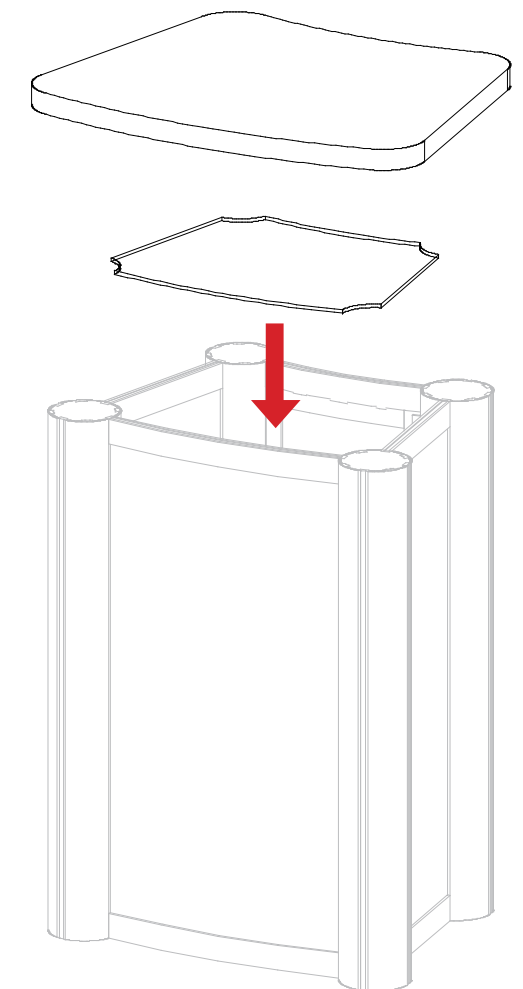
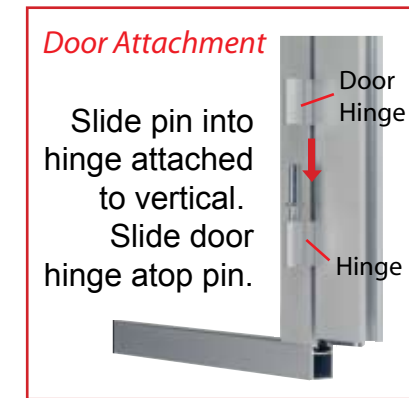
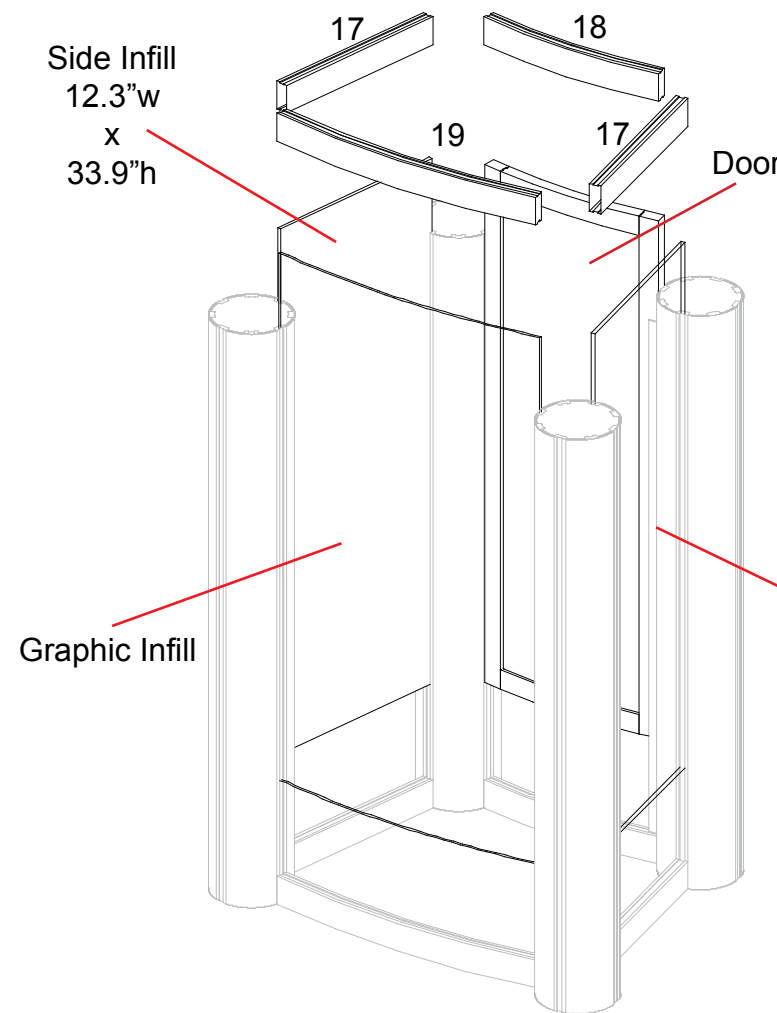
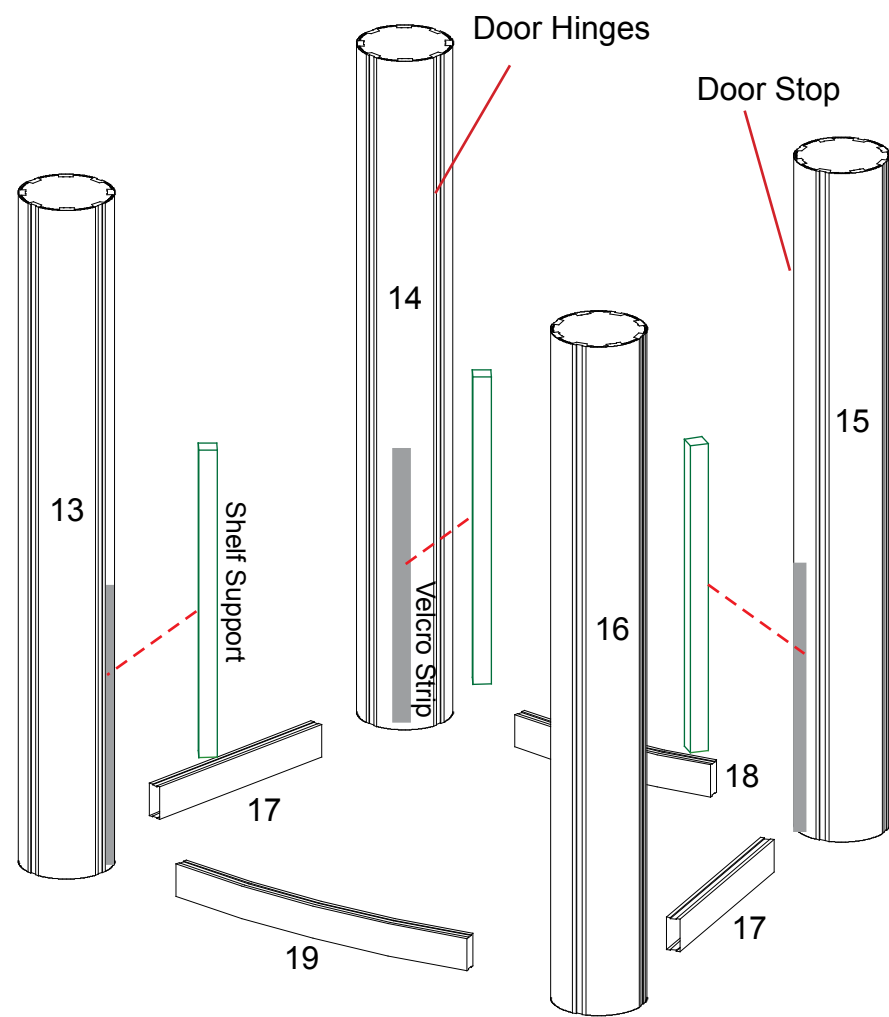
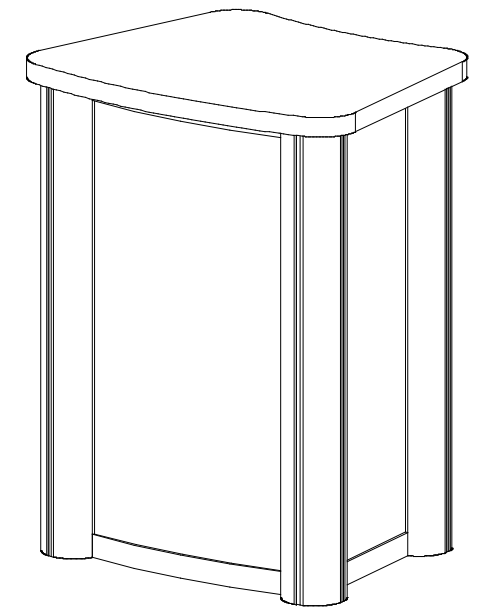

**WHEN DISASSEMBLING ALUMINUM EXTRUSION, TIGHTEN ALL SETSCREWS AND LOCKS TO PREVENT LOSS DURING SHIPPING**

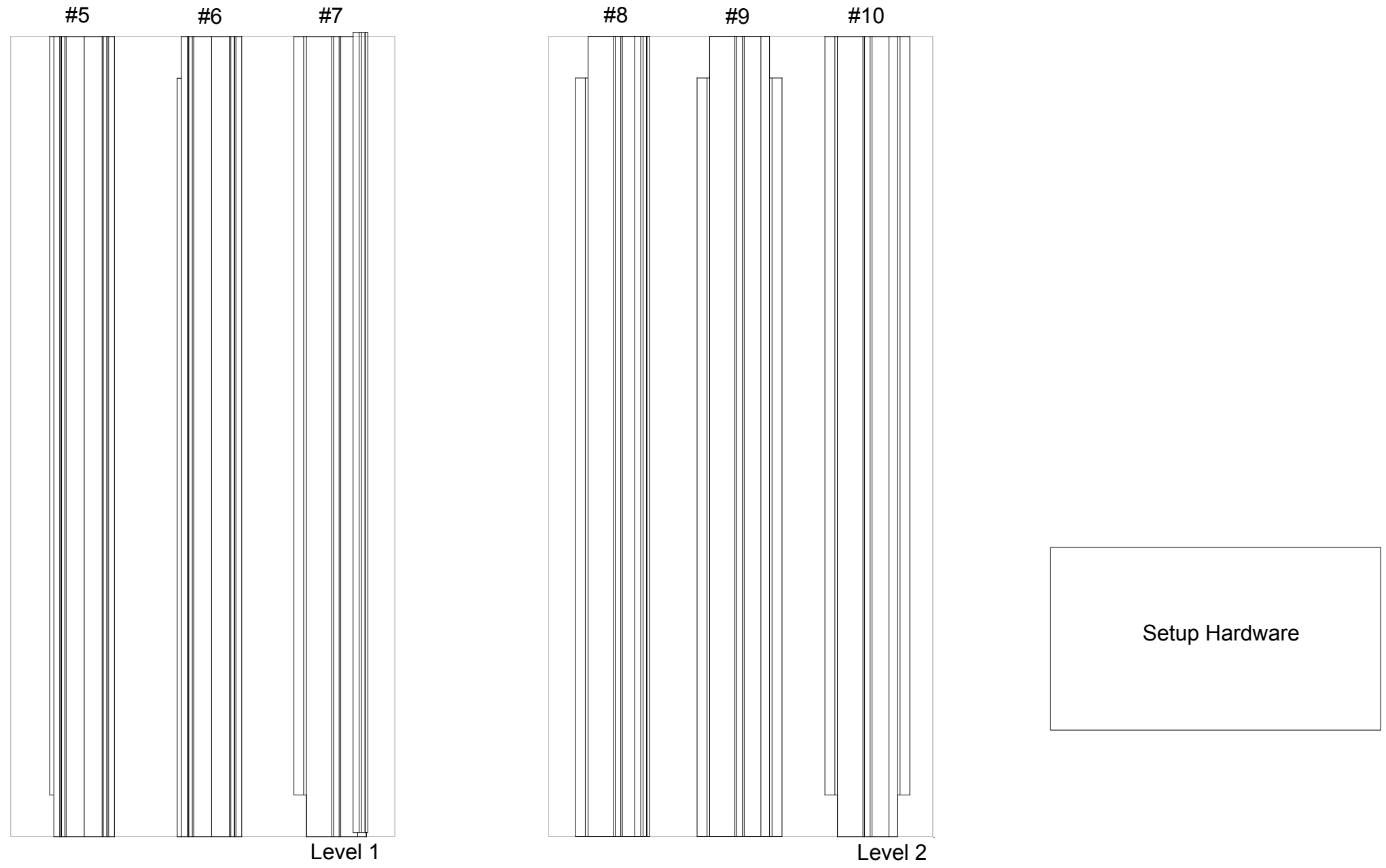

WHEN DISASSEMBLING ALUMINUM EXTRUSION, TIGHTEN ALL SETSCREWS AND LOCKS TO PREVENT LOSS DURING SHIPPING

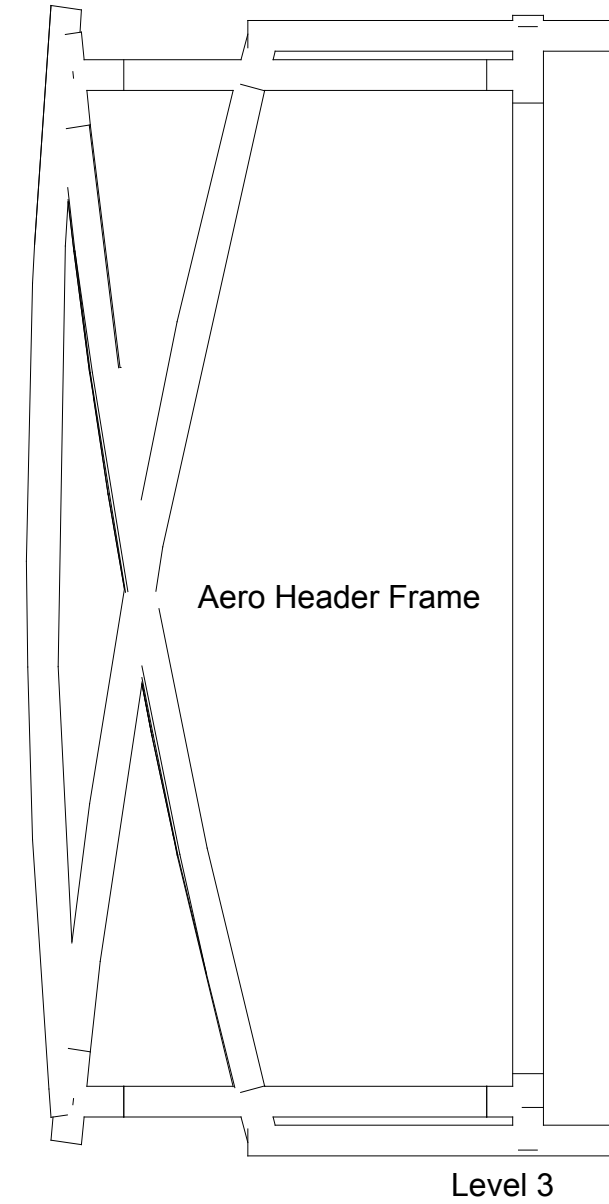
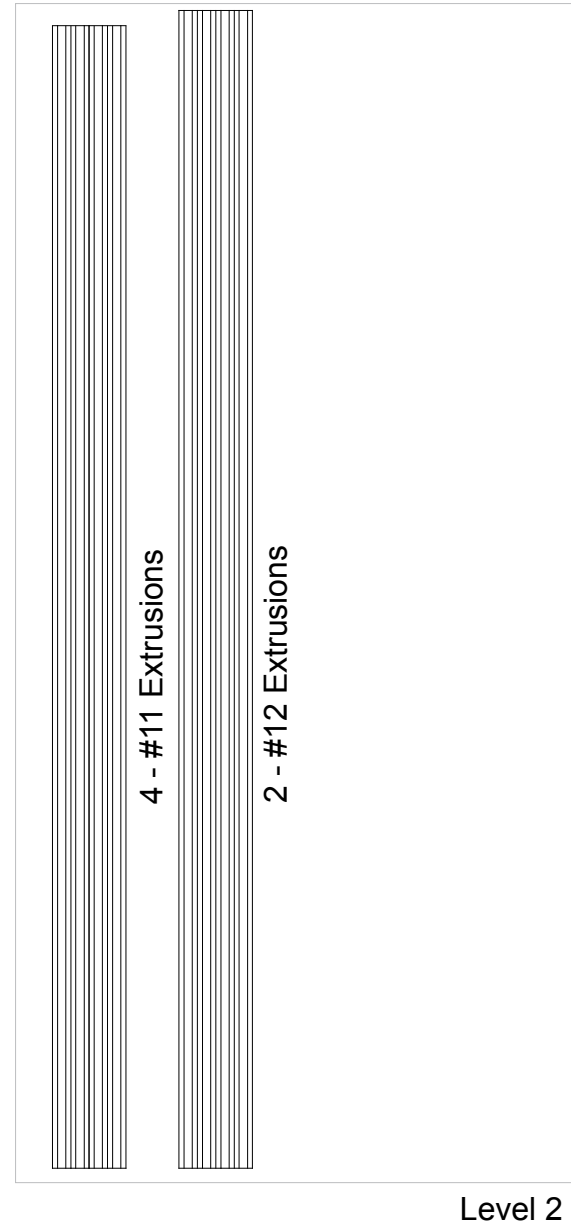
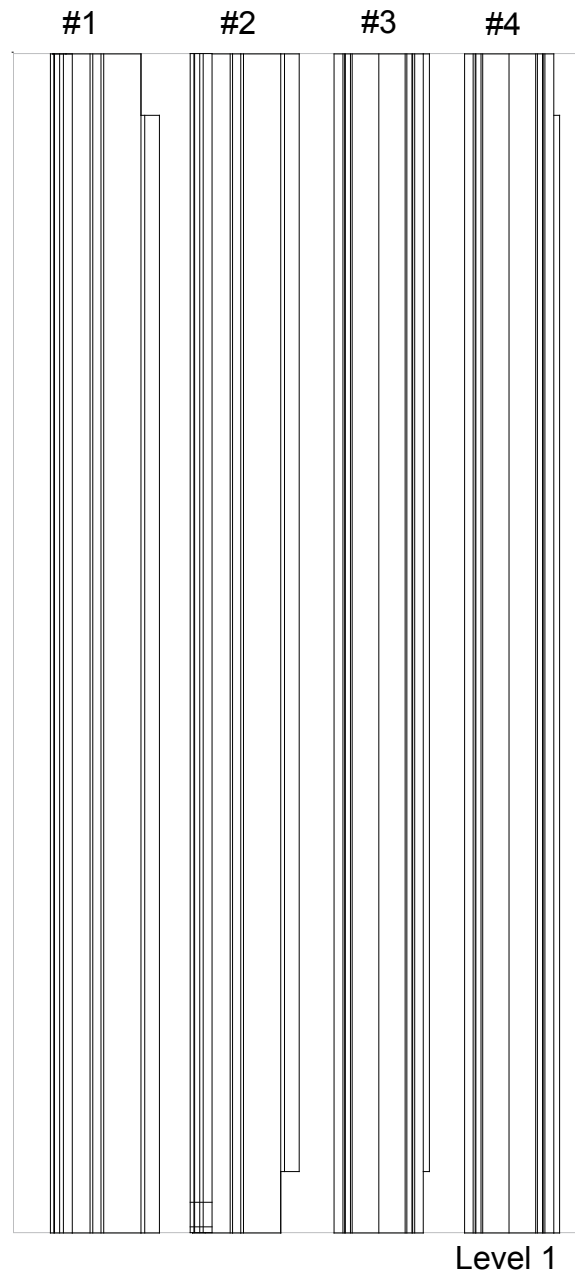

WHEN DISASSEMBLING ALUMINUM EXTRUSION, TIGHTEN ALL SETSCREWS AND LOCKS TO PREVENT LOSS DURING SHIPPING

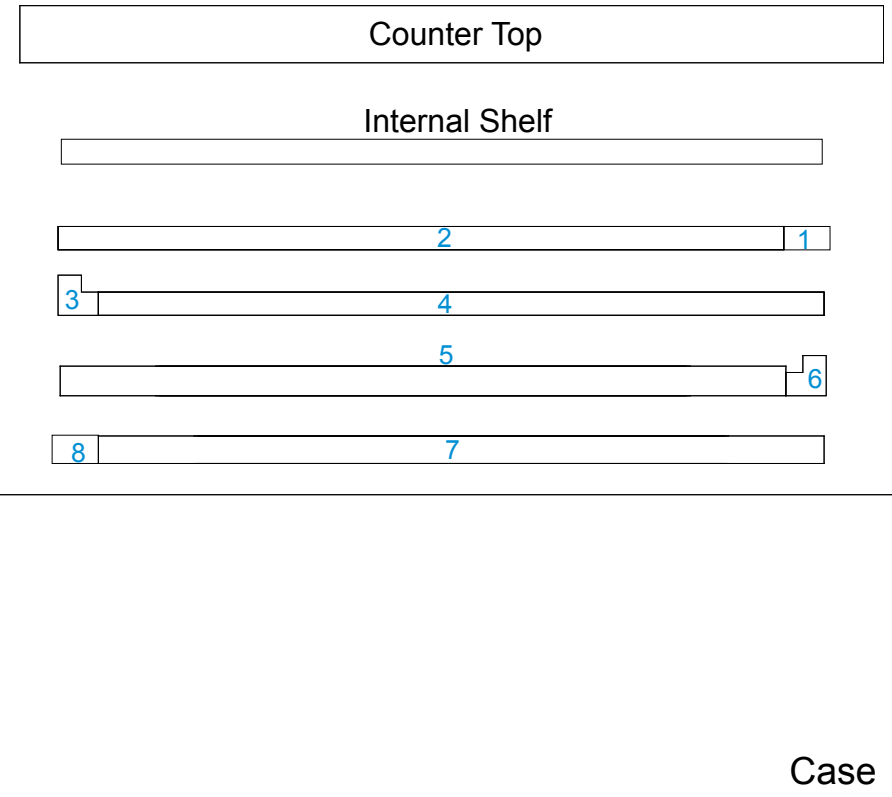

WHEN DISASSEMBLING ALUMINUM EXTRUSION, TIGHTEN ALL SETSCREWS AND LOCKS TO PREVENT LOSS DURING SHIPPING

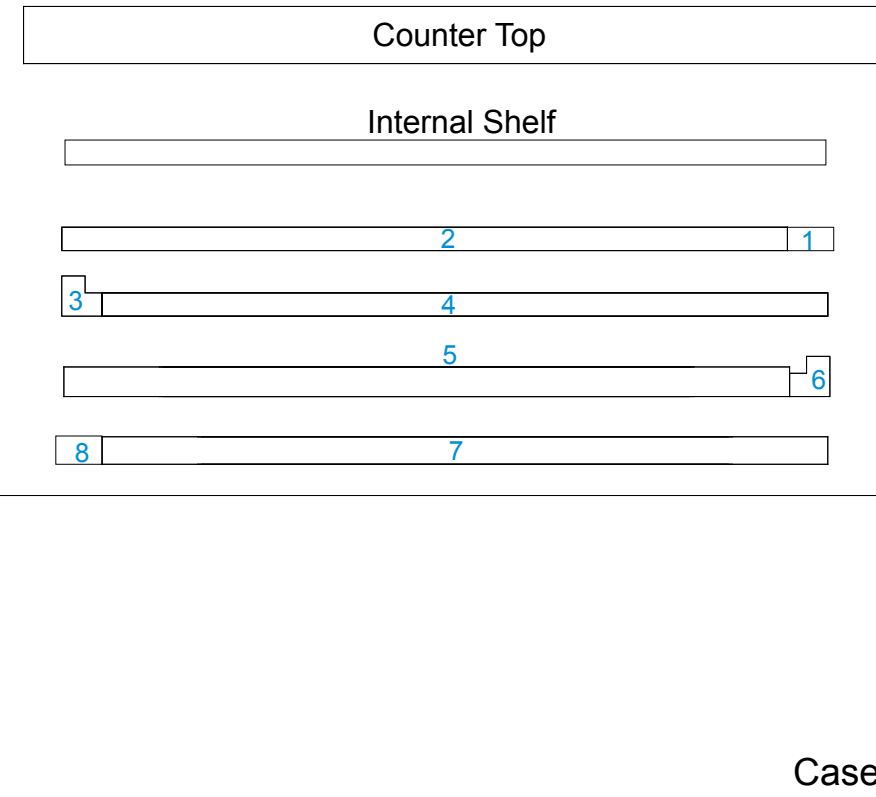

WHEN DISASSEMBLING ALUMINUM EXTRUSION, TIGHTEN ALL SETSCREWS AND LOCKS TO PREVENT LOSS DURING SHIPPING

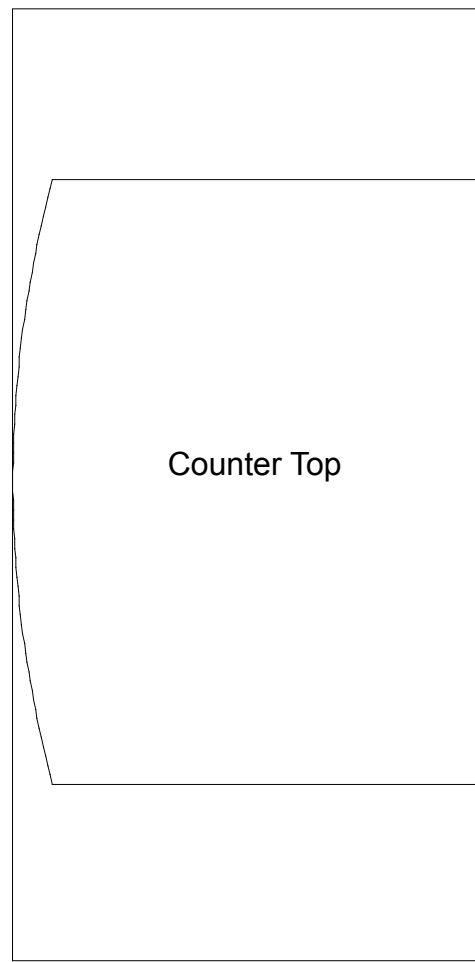

Level 1 [Bottom]

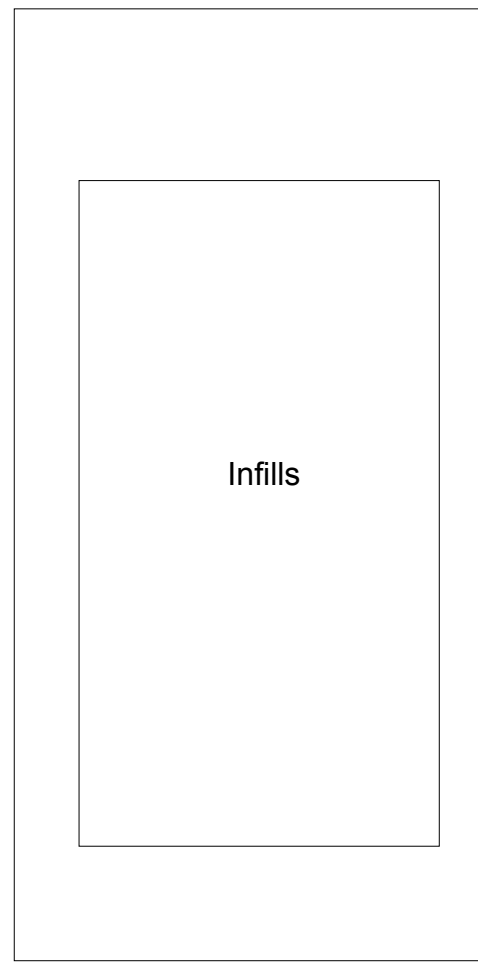

Level 2

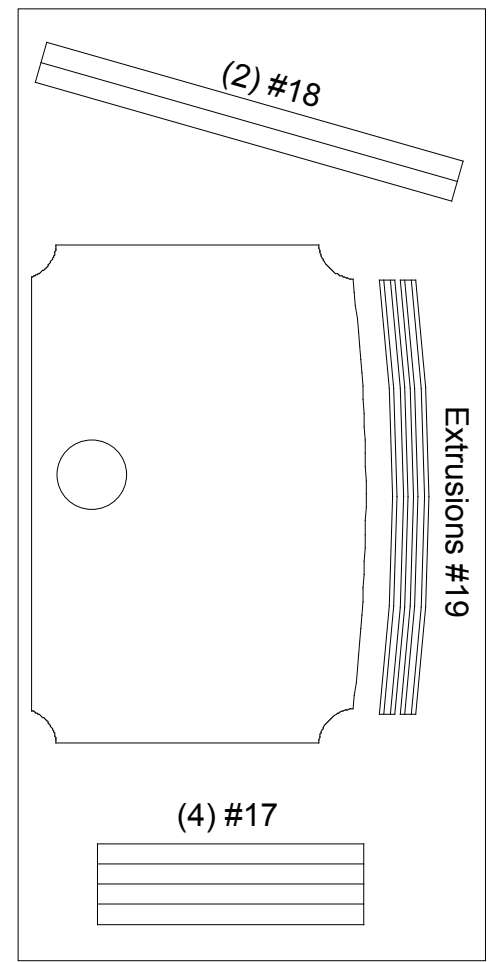

Level 3

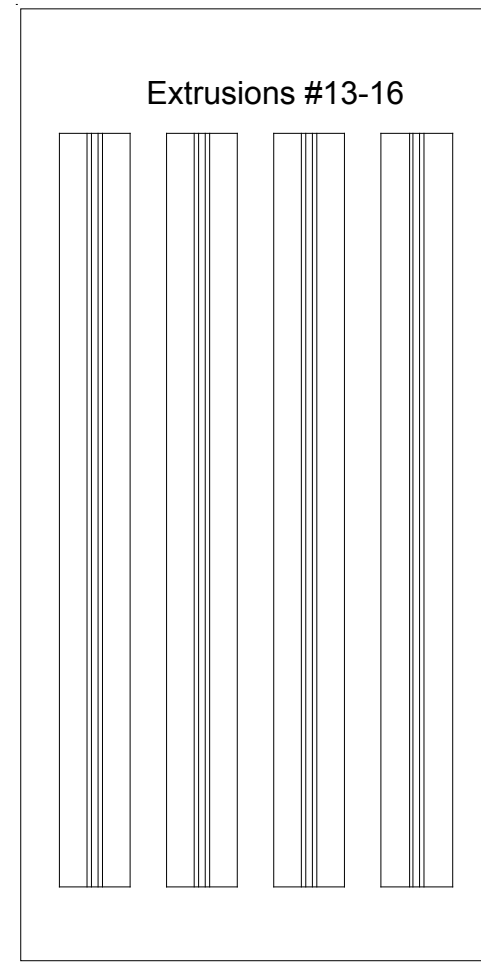

Level 4

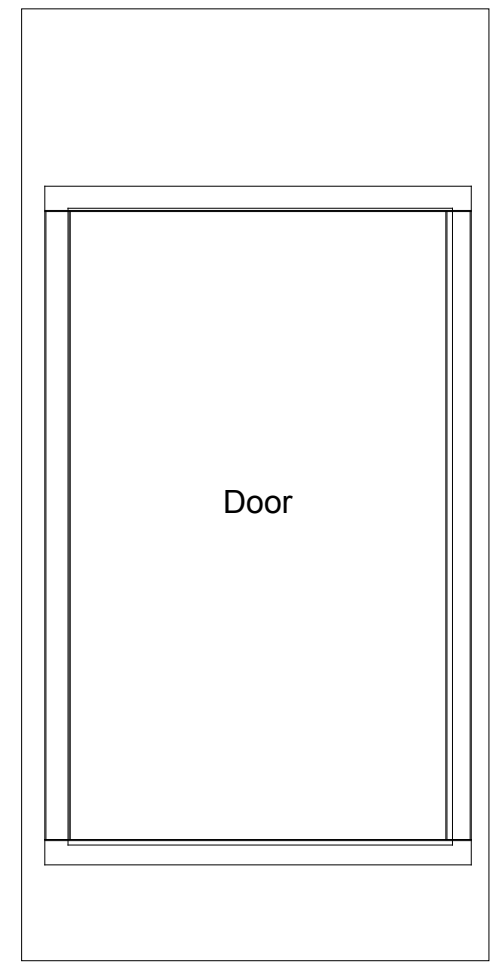

Level 5

WHEN DISASSEMBLING ALUMINUM EXTRUSION, TIGHTEN ALL SETSCREWS AND LOCKS TO PREVENT LOSS DURING SHIPPING