

euro It | HYBRIDS

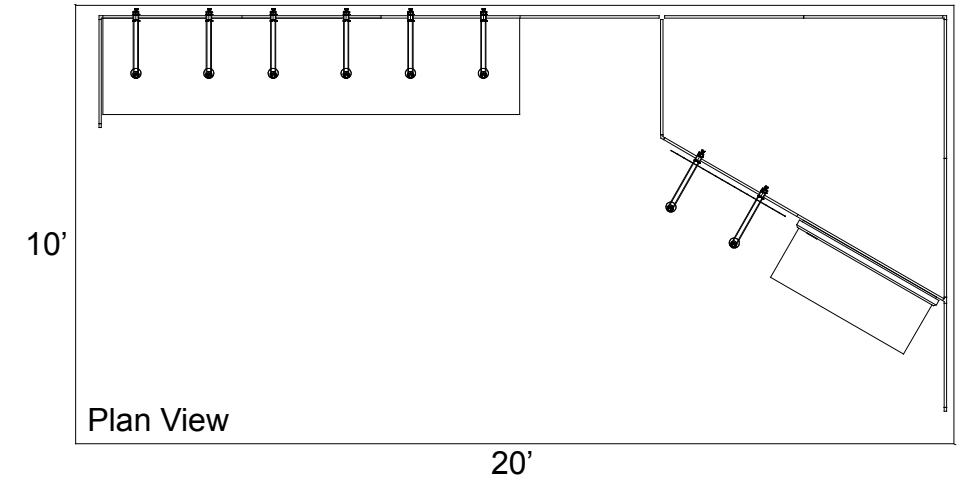
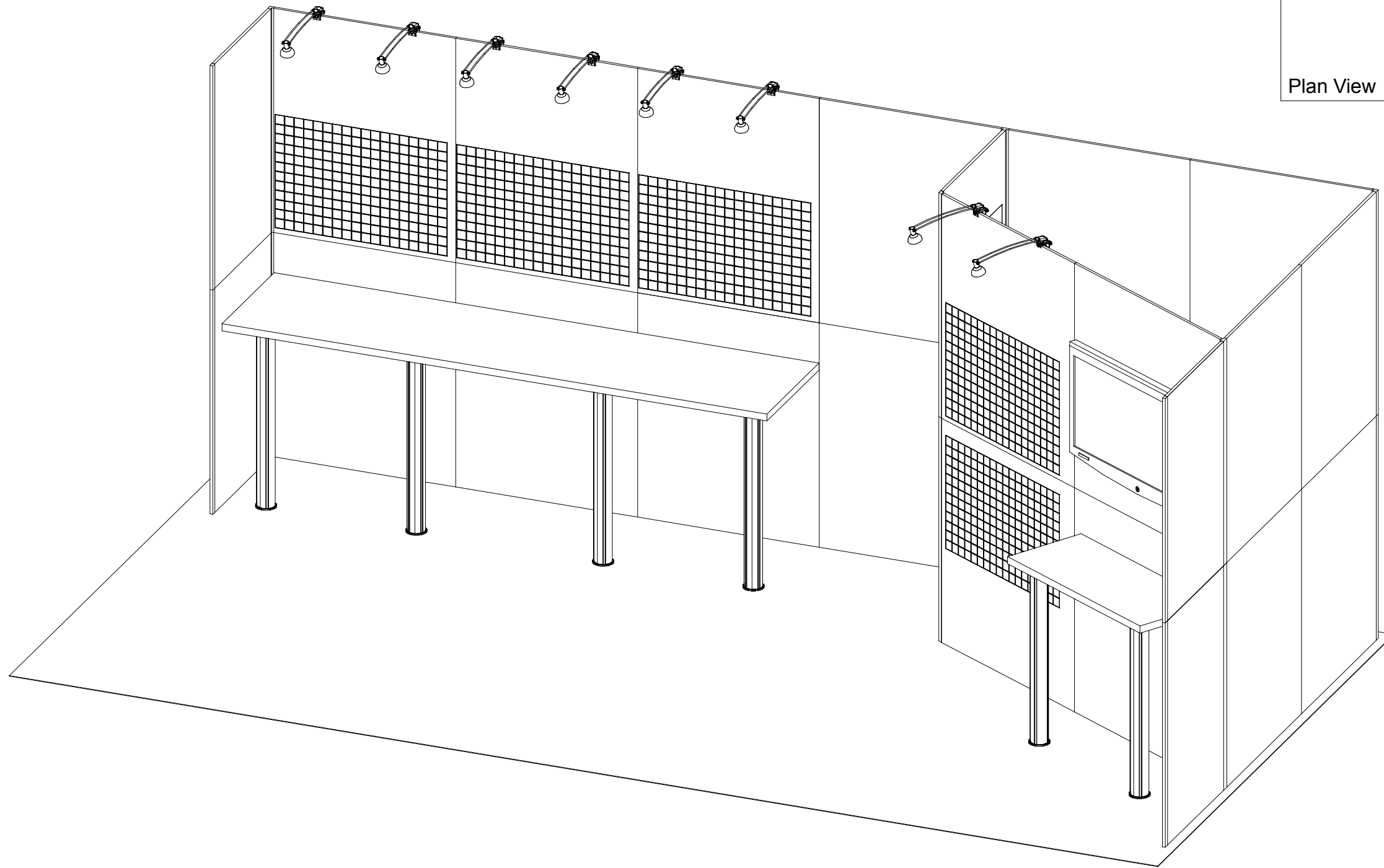

WHEN DISASSEMBLING ALUMINUM EXTRUSION, TIGHTEN ALL SETSCREWS AND LOCKS TO PREVENT LOSS DURING SHIPPING

euro lt | HYBRIDS

Using Your Setup Instructions

The Euro LT Hybrids Setup Instructions are created specifically for your configuration. They are laid out sequentially in levels, including exploded views, and a logical series of detailed steps to assemble the main structure and components. We encourage you to study the instructions **before** attempting to assemble your exhibit.

Each page reminds you to tighten the setscrews after disassembling your exhibit to prevent loss of the locks and setscrews (see below in RED). This is VERY IMPORTANT.

Cleaning and Packing Your Display

- 1) Use care when cleaning aluminum extrusion or acrylic inserts. Use only non-abrasive cleaners.
- 2) When cleaning laminate inserts, countertops, or panels use mild cleansers and a soft material such as cotton.
- 3) Keep all display components away from extreme heat and long exposure to sunlight to avoid warping and fading.
- 4) Retain all packing material. It will make re-packing much easier and will reduce the likelihood of shipping damage.

General Setup Instructions for Extrusion System



The Tool

Most exhibits can be assembled with the supplied Hex Key Tool. Occasionally, a flat head screwdriver may be required.



Typical Connection

Most horizontal extrusion connections have a patented expandable lock. This lock inserts into the groove of an opposing extrusion. Tightening the lock with the Hex Key Tool expands the lock and creates a strong positive connection.



Typical Connection (cont'd)

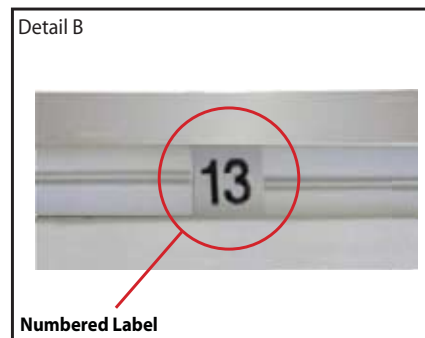

Numbered Label

Each extrusion contains a numbered label which corresponds with setup instructions. The label is located within a groove of the extrusion (when possible). With extrusion components the labels contain Black numbers unless otherwise specified.



Horizontal Inline Connection (remove only one setscrew)

Remove only (1) setscrew when disassembling. Replace setscrew in extrusion after assembling it. Before packing, replace setscrew in extrusion to avoid losing it.

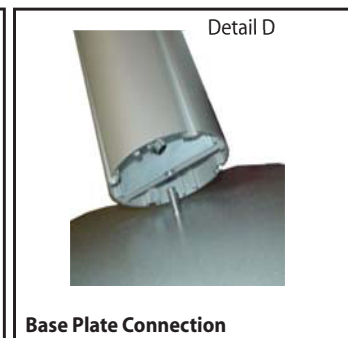

Base Plate Connection

Attach base plate to round or square vertical extrusion using the bolt provided. Be careful not to strip the threads.

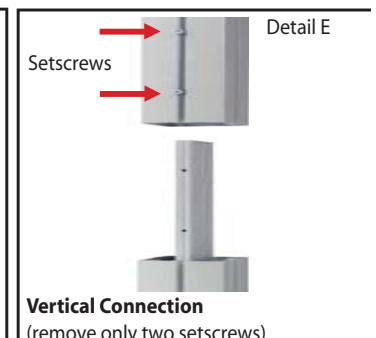

Vertical Connection (remove only two setscrews)

When vertical extrusions are packed in portable cases rather than crates or tubs, they must be broken down into smaller section which then require assembly.

Remove only (2) setscrews when disassembling. Replace setscrews in extrusion after assembling it. Before packing, replace setscrews in extrusion to avoid losing them.

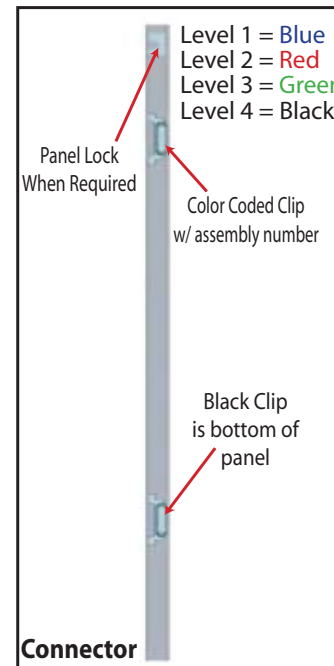

Connector

Each component has 2 clips, the lower clip is ALWAYS black. The top clip is color coded to distinguish which level. The color coded clip also contains the numbered label.

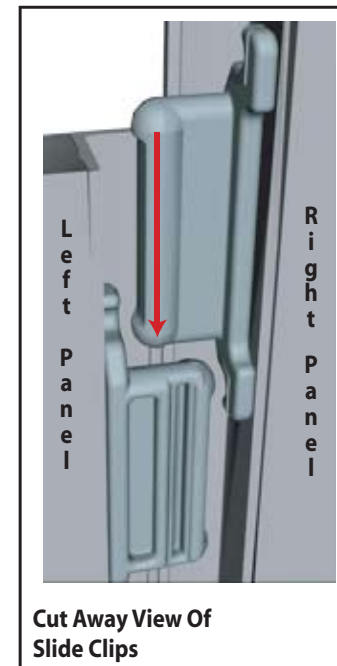

Cut Away View Of Slide Clips

Components connect together by aligning them and sliding downward connecting clips together.

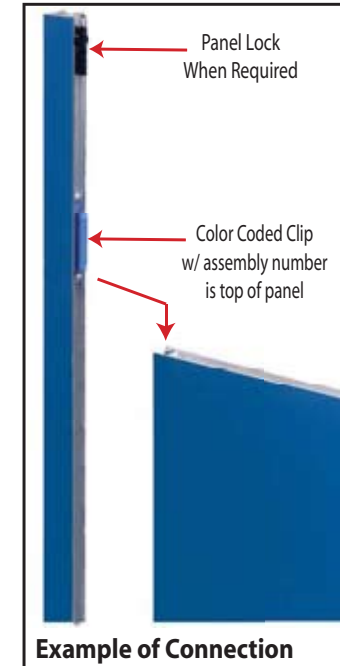

Example of Connection

Configurations are assembled from left to right, usually starting with #1 and following the numbered sequence.

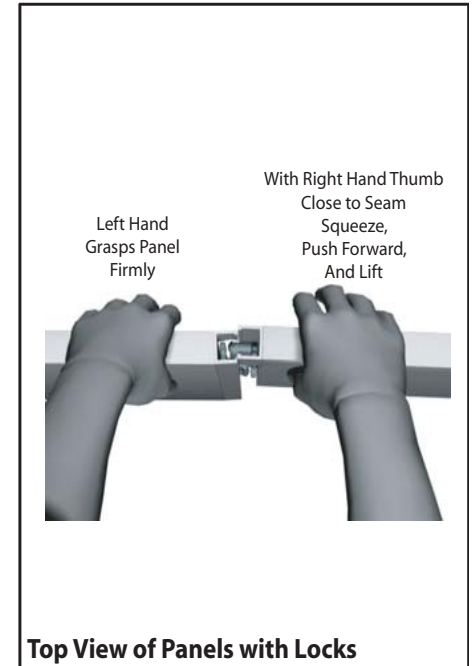

Top View of Panels with Locks

The first level of components contain panel locks that are located at the top of the panel for extra stability and seamless connection. When disassembling panels twist top connection slightly and lift right panel upward.

WHEN DISASSEMBLING ALUMINUM EXTRUSION, TIGHTEN ALL SETSCREWS AND LOCKS TO PREVENT LOSS DURING SHIPPING

866.652.2100

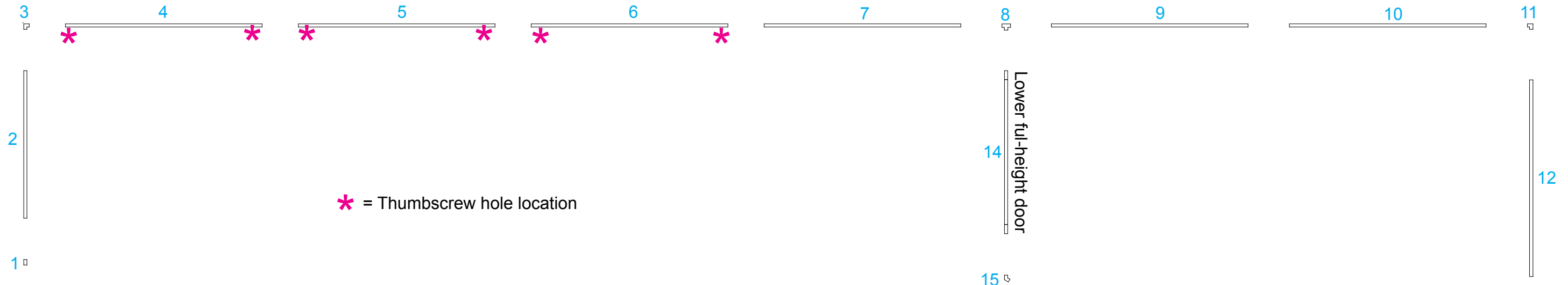

* = Thumbscrew hole location

Steps:
1) Assemble backwall panels and connectors together in numerical order.

Item Number	Description
1	47.5"h End Cap
2	28"w x 47.5"h Flat Panel
3	47.5"h 90° Connector
4	38"w x 47.5"h Flat Panel
5	38"w x 47.5"h Flat Panel
6	38"w x 47.5"h Flat Panel
7	38"w x 47.5"h Flat Panel
8	47.5"h 90° Connector
9	38"w x 47.5"h Flat Panel
10	38"w x 47.5"h Flat Panel
11	47.5"h 90° Connector
12	38"w x 47.5"h Flat Panel
13	38"w x 47.5"h Flat Panel
14	Lower Door
15	47.5"h 120° Connector
16	42"w x 47.5"h Flat Panel
17	46"w x 47.5"h Flat Panel
18	47.5"h 3-way Connector
19	28"w x 47.5"h Flat Panel
20	47.5"h End Cap

WHEN DISASSEMBLING ALUMINUM EXTRUSION, TIGHTEN ALL SETSCREWS AND LOCKS TO PREVENT LOSS DURING SHIPPING

866.652.2100

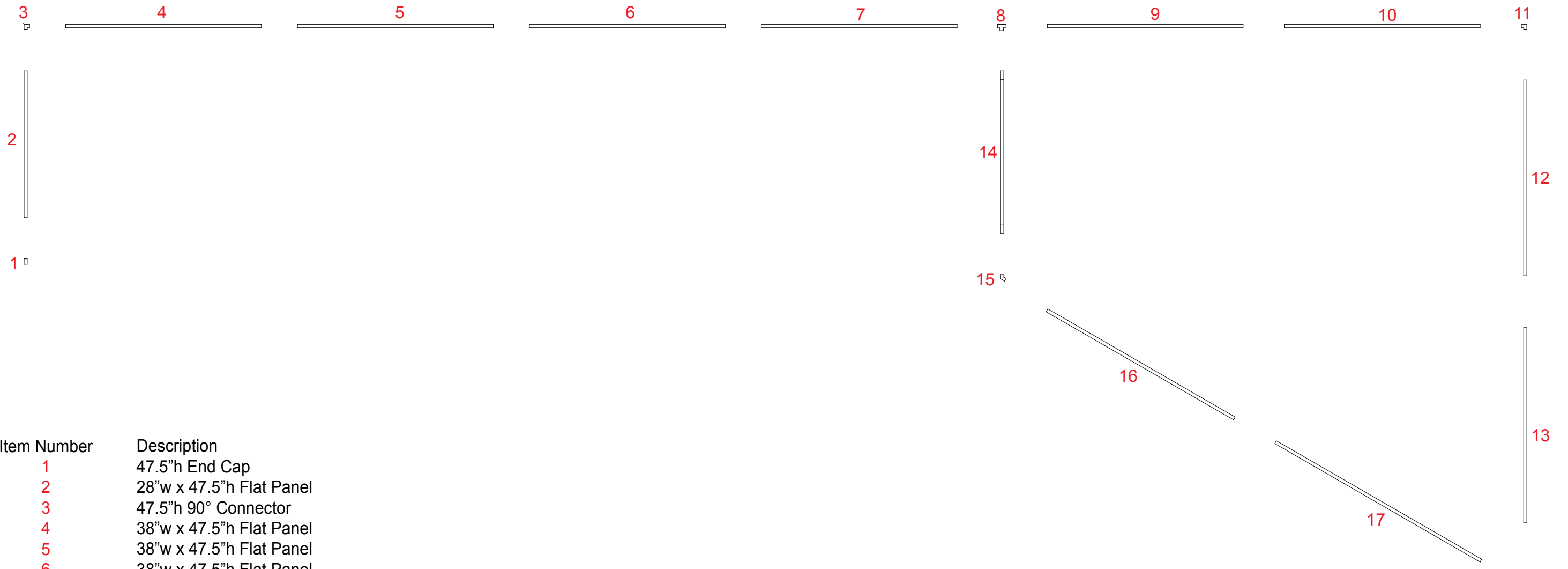

Item Number	Description
1	47.5”h End Cap
2	28”w x 47.5”h Flat Panel
3	47.5”h 90° Connector
4	38”w x 47.5”h Flat Panel
5	38”w x 47.5”h Flat Panel
6	38”w x 47.5”h Flat Panel
7	38”w x 47.5”h Flat Panel
8	47.5”h 90° Connector
9	38”w x 47.5”h Flat Panel
10	38”w x 47.5”h Flat Panel
11	47.5”h 90° Connector
12	38”w x 47.5”h Flat Panel
13	38”w x 47.5”h Flat Panel
14	Upper Door
15	47.5”h 120° Connector
16	42”w x 47.5”h Flat Panel
17	46”w x 47.5”h Flat Panel
18	47.5”h 3-way Connector
19	28”w x 47.5”h Flat Panel
20	47.5”h End Cap

Steps:

1) Assemble backwall panels and connectors together in numerical order.

WHEN DISASSEMBLING ALUMINUM EXTRUSION, TIGHTEN ALL SETSCREWS AND LOCKS TO PREVENT LOSS DURING SHIPPING

866.652.2100

Item	QTY.	Description
1	6	Base Plate
2	6	38" h Round Vertical Extrusion
3	6	Flange Plate
4	3	Stiffener Bar

Steps:

- 1) Attach base plates [1] to round verticals [2].
- 2) Attach flange plates [3] to top of verticals [2].
- 3) Set counter tops on vertical supports and secure with wing nuts as shown.
- 4) Hook stiffener bars to top of assembled structure where indicated.
- 5) Attach monitor mount to assembled backwall where indicated.
- 6) Attach hooks to backwall panels for gridwall attachment.

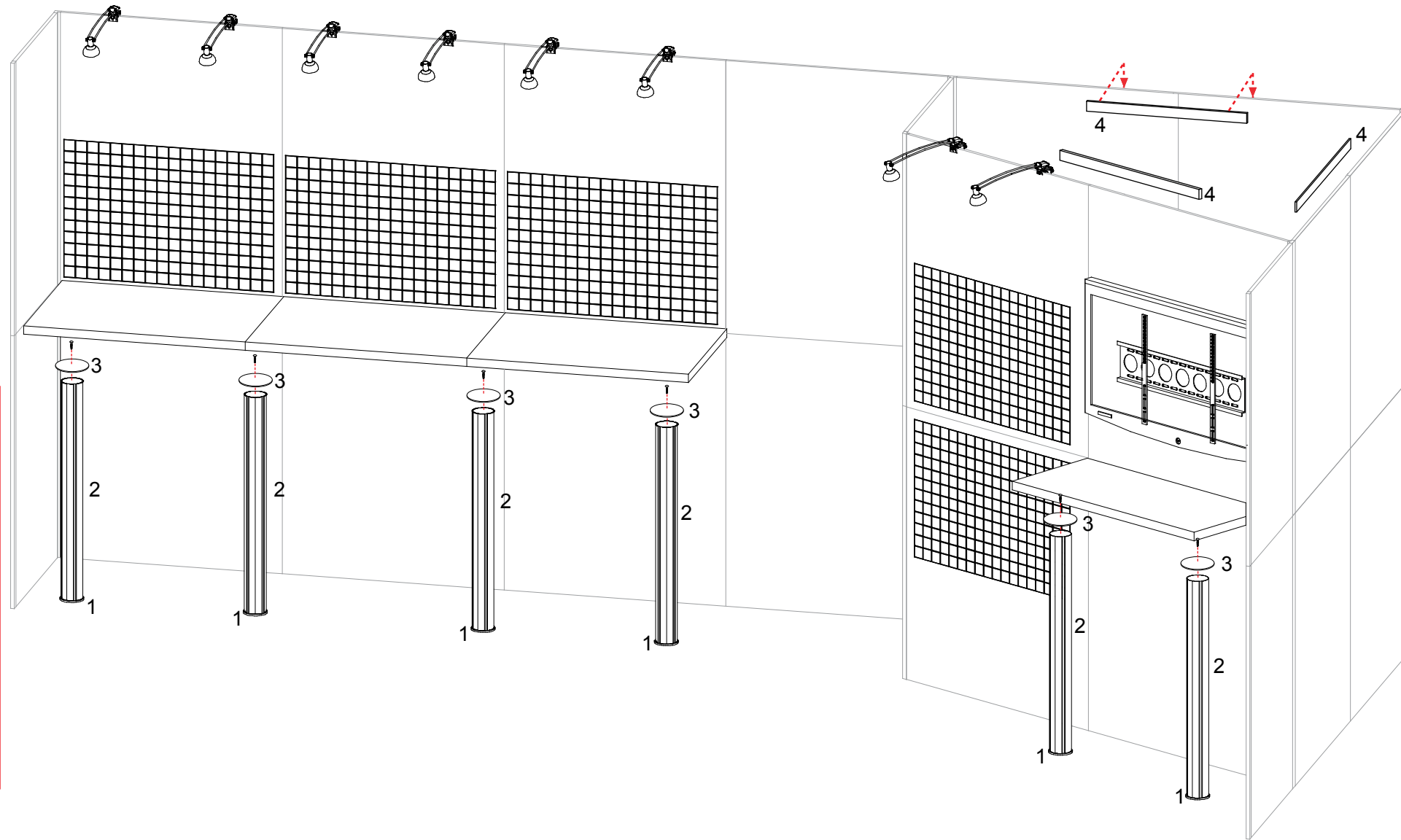
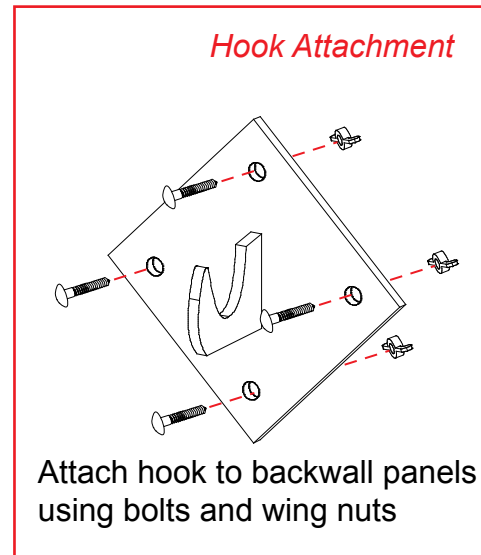
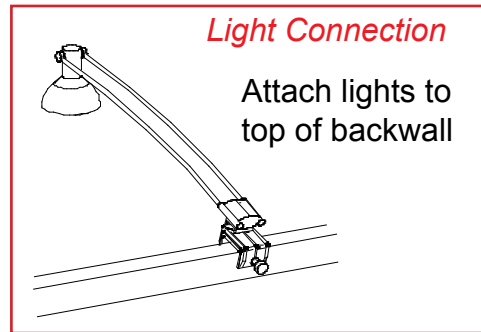

Counter Top Attachment

Insert screws located on underside of counter into holes on flange plate and secure with wing nuts.

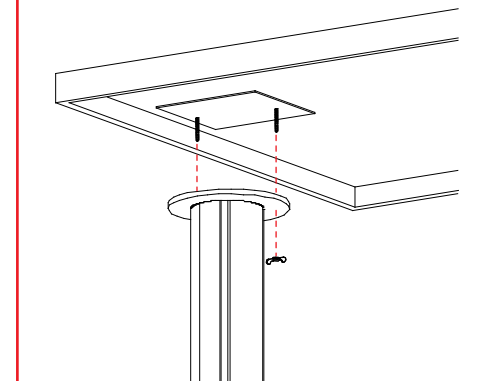

Monitor Mount Attachment

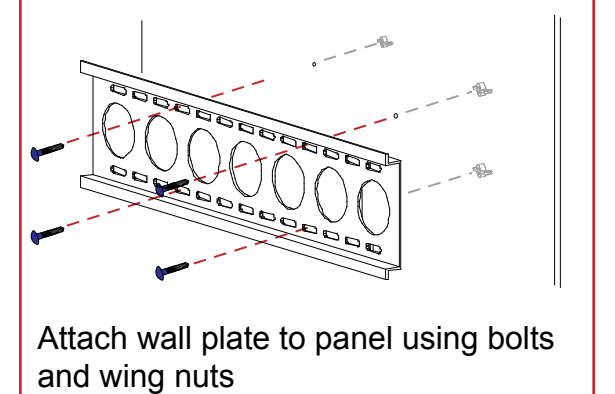

WHEN DISASSEMBLING ALUMINUM EXTRUSION, TIGHTEN ALL SETSCREWS AND LOCKS TO PREVENT LOSS DURING SHIPPING

Front View of Tub

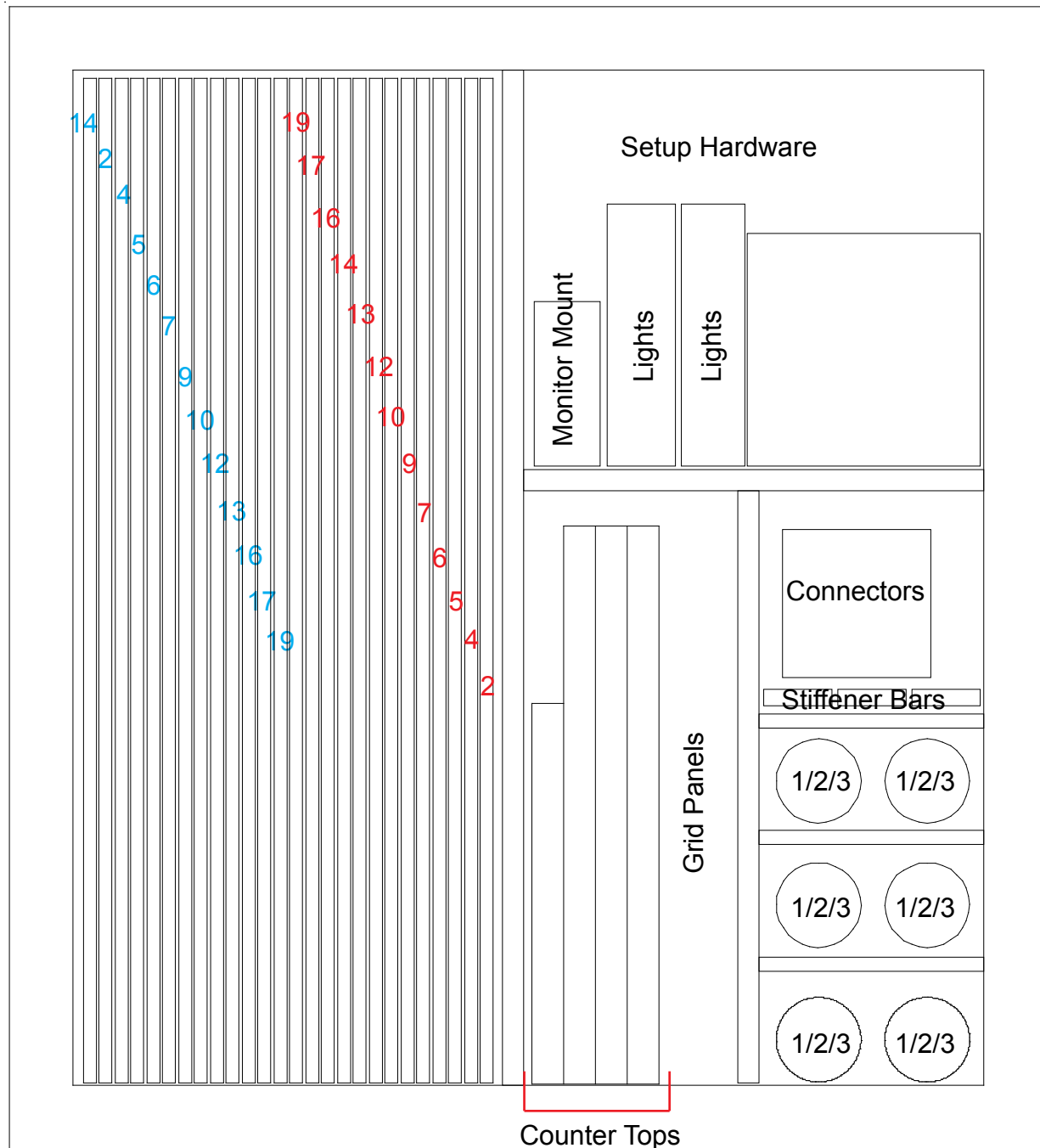

WHEN DISASSEMBLING ALUMINUM EXTRUSION, TIGHTEN ALL SETSCREWS AND LOCKS TO PREVENT LOSS DURING SHIPPING