

euro It | *HYBRIDS*

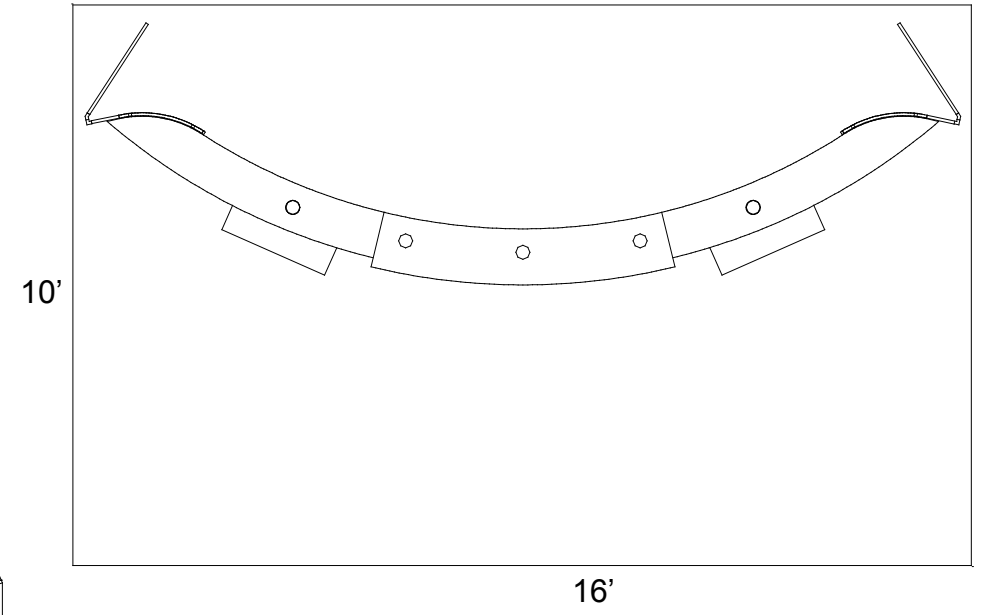
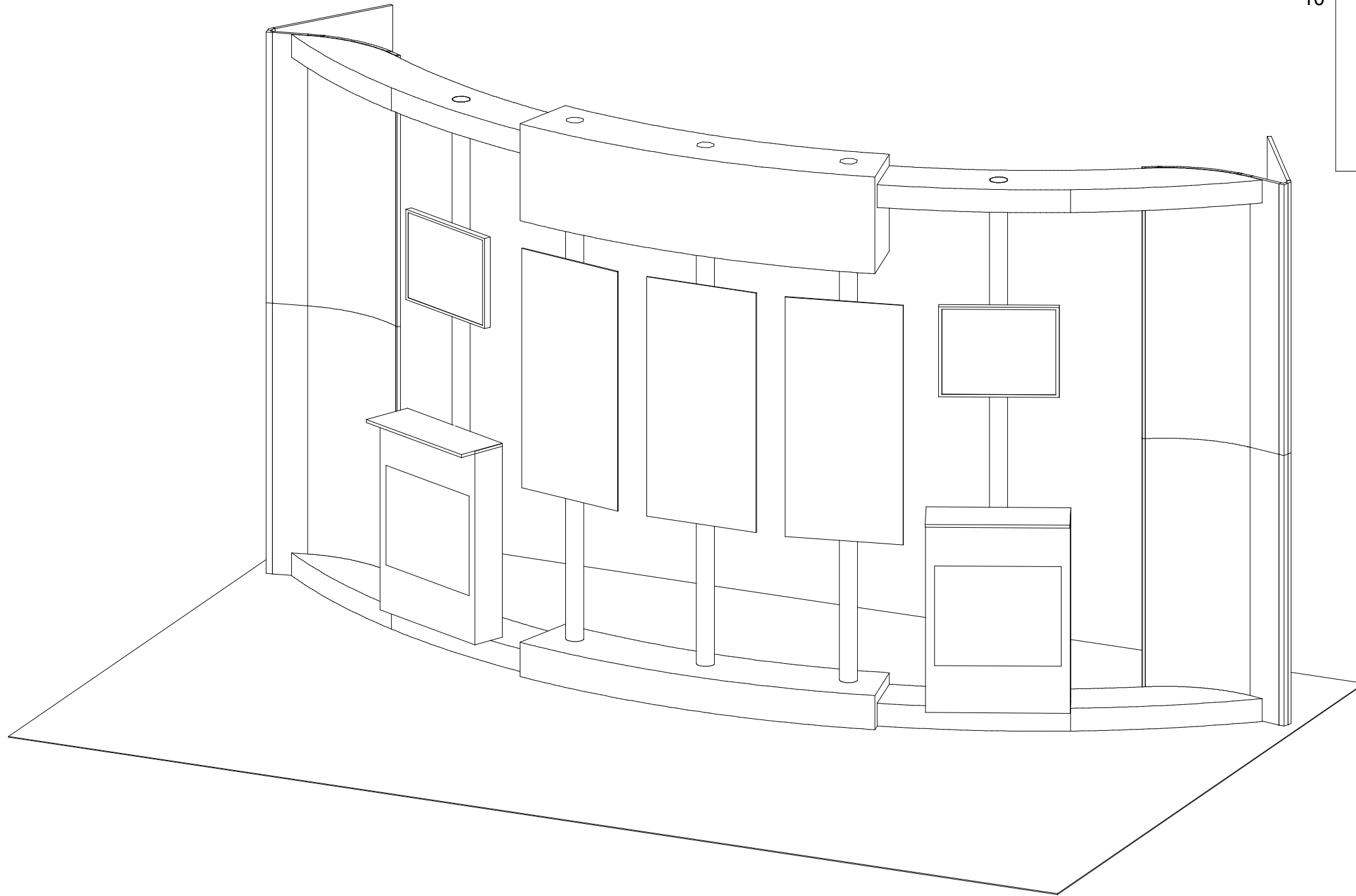

WHEN DISASSEMBLING ALUMINUM EXTRUSION, TIGHTEN ALL SETSCREWS AND LOCKS TO PREVENT LOSS DURING SHIPPING

euro lt | HYBRIDS

Using Your Setup Instructions

The Euro LT Hybrids Setup Instructions are created specifically for your configuration. They are laid out sequentially in levels, including exploded views, and a logical series of detailed steps to assemble the main structure and components. We encourage you to study the instructions **before** attempting to assemble your exhibit.

Each page reminds you to tighten the setscrews after disassembling your exhibit to prevent loss of the locks and setscrews (see below in RED). This is VERY IMPORTANT.

Cleaning and Packing Your Display

- 1) Use care when cleaning aluminum extrusion or acrylic inserts. Use only non-abrasive cleaners.
- 2) When cleaning laminate inserts, countertops, or panels use mild cleansers and a soft material such as cotton.
- 3) Keep all display components away from extreme heat and long exposure to sunlight to avoid warping and fading.
- 4) Retain all packing material. It will make re-packing much easier and will reduce the likelihood of shipping damage.

General Setup Instructions for Extrusion System



Most exhibits can be assembled with the supplied Hex Key Tool. Occasionally, a flat head screwdriver may be required.



Most horizontal extrusion connections have a patented expandable lock. This lock inserts into the groove of an opposing extrusion. Tightening the lock with the Hex Key Tool expands the lock and creates a strong positive connection.

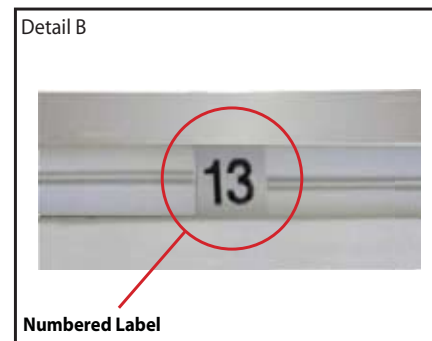

Each extrusion contains a numbered label which corresponds with setup instructions. The label is located within a groove of the extrusion (when possible). With extrusion components the labels contain Black numbers unless otherwise specified.



Remove only (1) setscrew when disassembling. Replace setscrew in extrusion after assembling it. Before packing, replace setscrew in extrusion to avoid losing it.

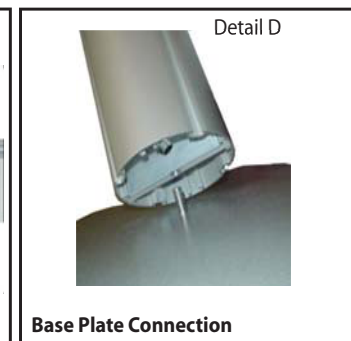

Attach base plate to round or square vertical extrusion using the bolt provided. Be careful not to strip the threads.

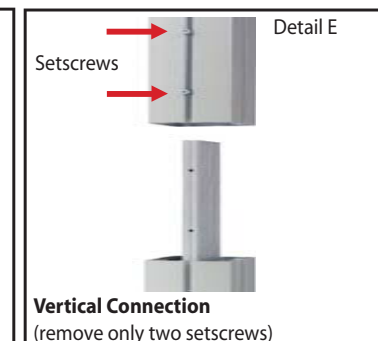

When vertical extrusions are packed in portable cases rather than crates or tubs, they must be broken down into smaller section which then require assembly.

Remove only (2) setscrews when disassembling. Replace setscrews in extrusion after assembling it. Before packing, replace setscrews in extrusion to avoid losing them.

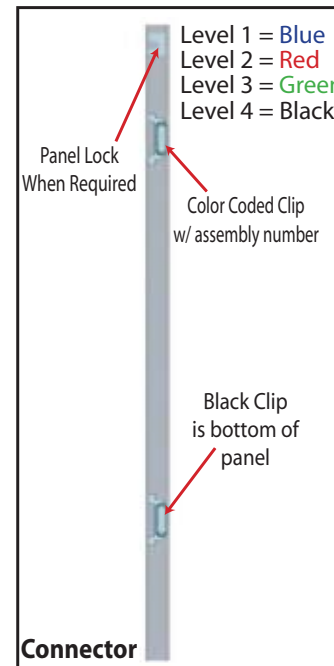

Each component has 2 clips, the lower clip is ALWAYS black. The top clip is color coded to distinguish which level. The color coded clip also contains the numbered label.

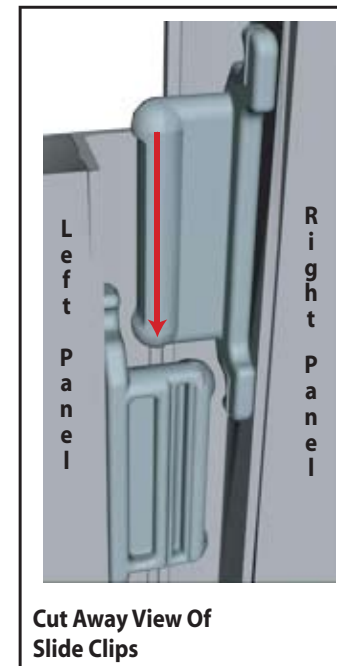

Components connect together by aligning them and sliding downward connecting clips together.

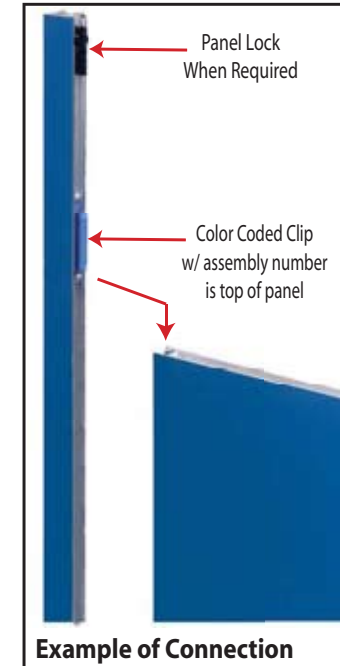

Configurations are assembled from left to right, usually starting with #1 and following the numbered sequence.

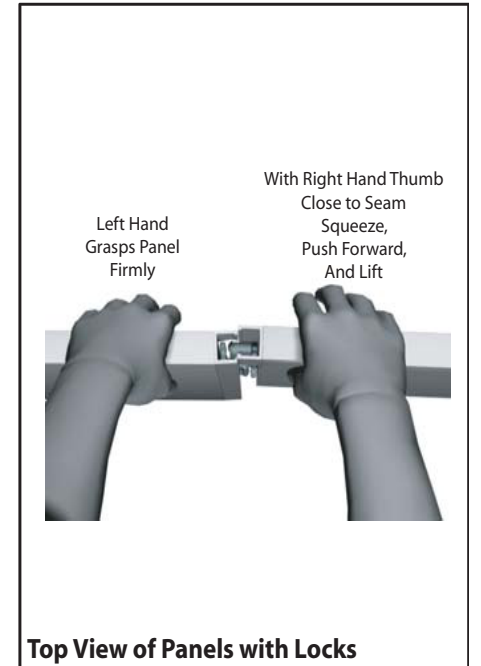

The first level of components contain panel locks that are located at the top of the panel for extra stability and seamless connection. When disassembling panels twist top connection slightly and lift right panel upward.

WHEN DISASSEMBLING ALUMINUM EXTRUSION, TIGHTEN ALL SETSCREWS AND LOCKS TO PREVENT LOSS DURING SHIPPING

Item	Description
1	47.5"h Endcap
2	23"w x 47.5"h Flat Panel
6	47.5"h 135° Connector
3	47.5"h 90° Connector
3a	6"w x 47.5"h Flat Panel
16	23"r x 47.5"h Curved Panel
17	47.5"h Endcap
18	47.5"h Endcap
19	23"r x 47.5"h Curved Panel
32a	6"w x 47.5"h Flat Panel
32	47.5"h 90° Connector
29	47.5"h 135° Connector
33	23"w x 47.5"h Flat Panel
34	47.5"h Endcap

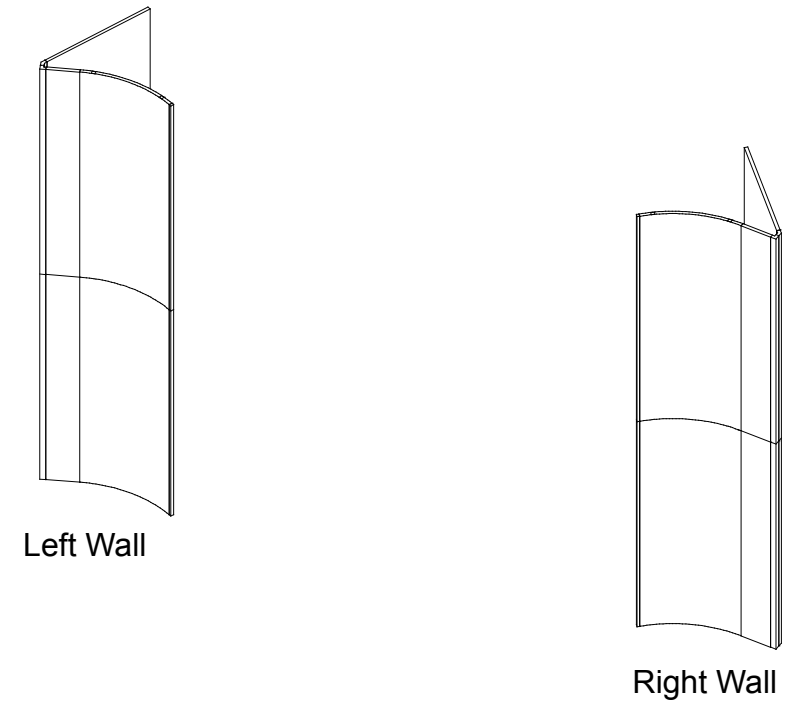
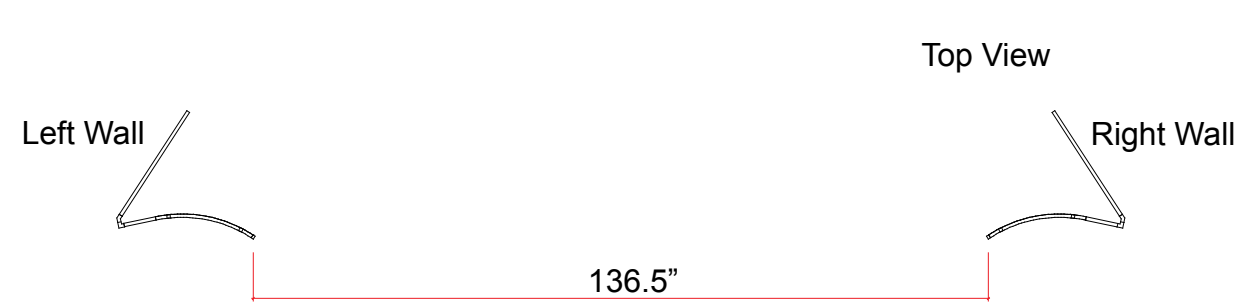

- Steps:
- 1) Assemble panels and connectors as shown.
 - 2) Set assembled walls on floor as indicated, see above top view.



WHEN DISASSEMBLING ALUMINUM EXTRUSION, TIGHTEN ALL SETSCREWS AND LOCKS TO PREVENT LOSS DURING SHIPPING

Item	Description
1	47.5"h Endcap
2	23"w x 47.5"h Flat Panel
6	47.5"h 135° Connector
3	47.5"h 90° Connector
3a	6"w x 47.5"h Flat Panel
16	23"r x 47.5"h Curved Panel
17	47.5"h Endcap
18	47.5"h Endcap
19	23"r x 47.5"h Curved Panel
32a	6"w x 47.5"h Flat Panel
32	47.5"h 90° Connector
29	47.5"h 135° Connector
33	23"w x 47.5"h Flat Panel
34	47.5"h Endcap

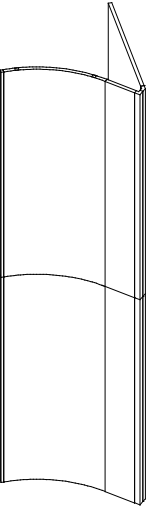
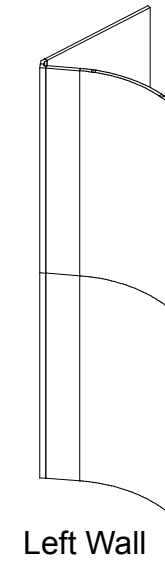
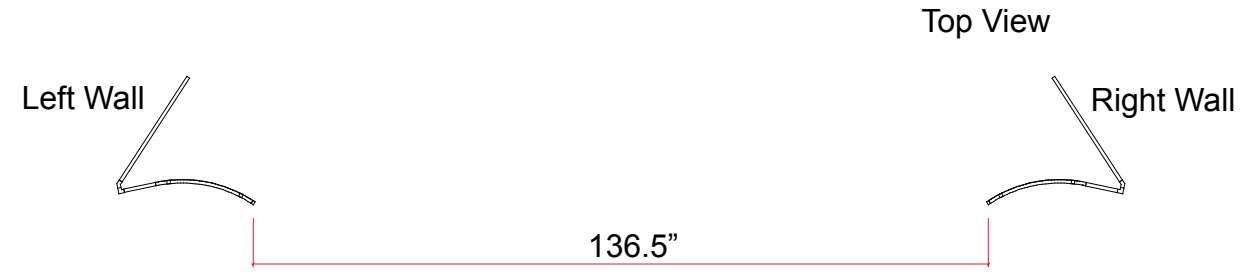

- Steps:
- 1) Assemble panels and connectors as shown.
 - 2) Set assembled walls on floor as indicated, see above top view.

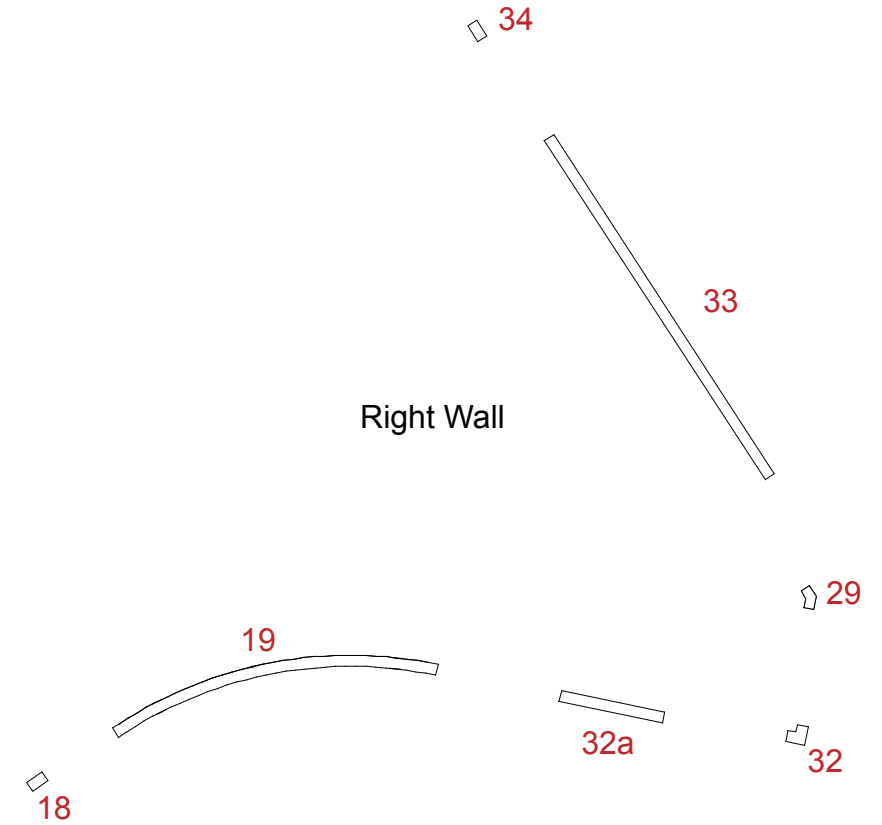
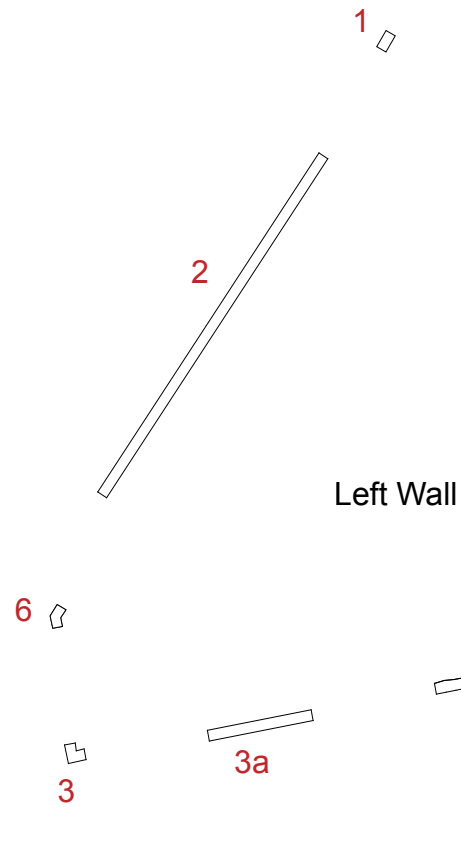

WHEN DISASSEMBLING ALUMINUM EXTRUSION, TIGHTEN ALL SETSCREWS AND LOCKS TO PREVENT LOSS DURING SHIPPING



Steps:

- 1) Connect base and header pieces together using bolts and wing nuts.
- 2) Insert screwcaps into groove of uprights for laptop box attachment.

Note: Screwcaps and monitor mount connectors must face forward.

- 3) Insert upright into holes on bases as shown.

- 4) Set assembled header on uprights and hook onto top of side walls as shown.

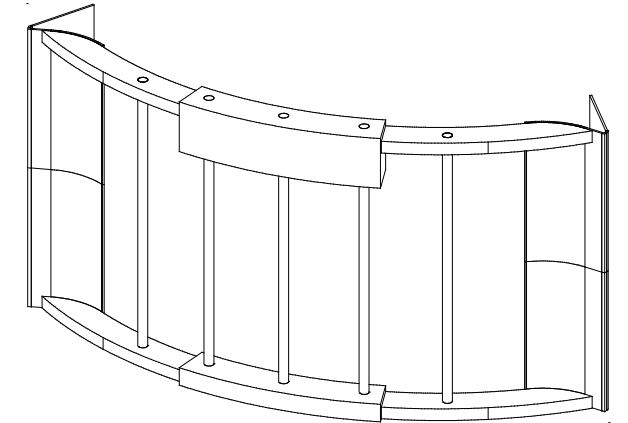

Connectors for monitor mount attachment must stay attached to vertical.

Adjustable collar

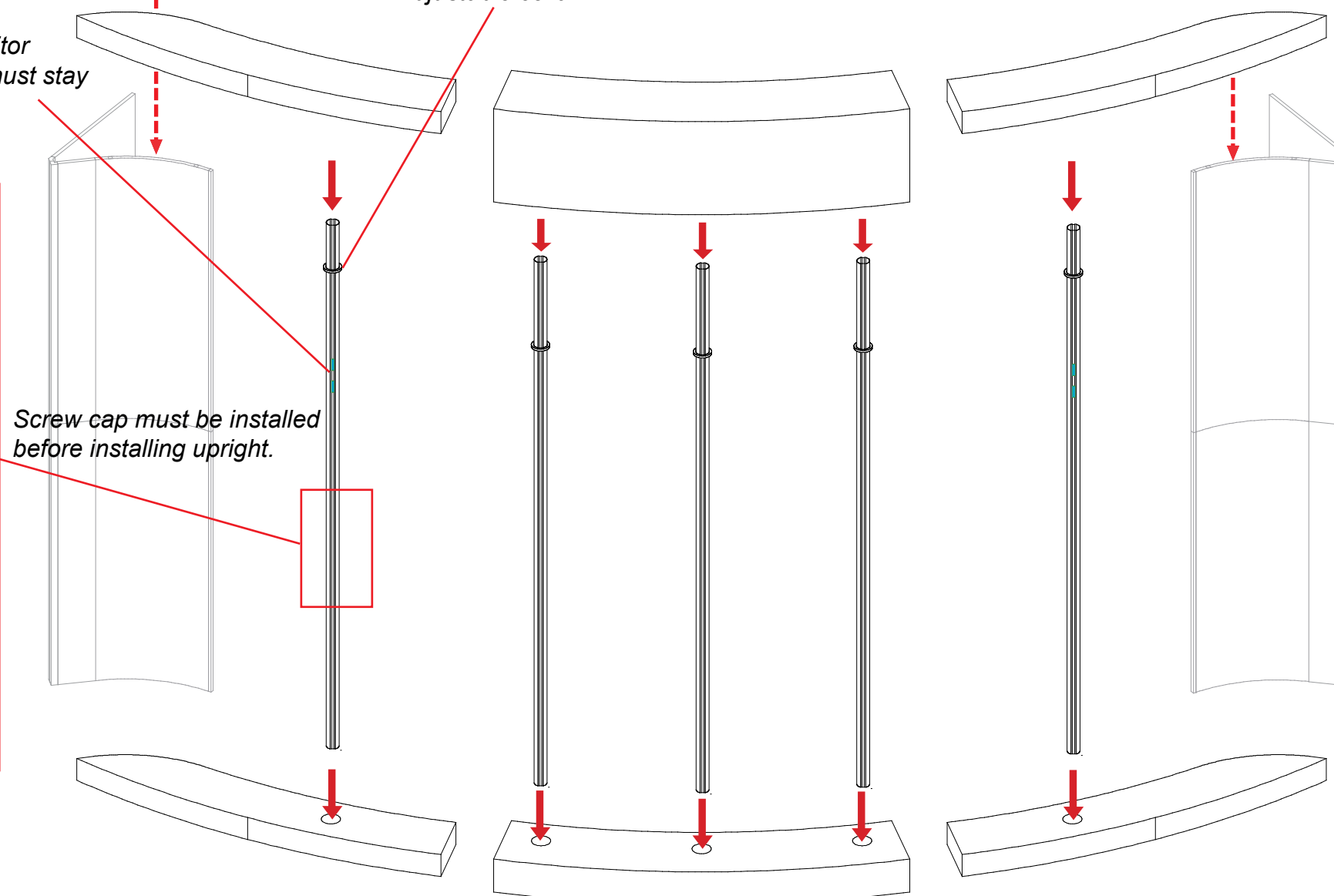

Screw cap must be installed before installing upright.

Screwcap Attachment for Laptop Box Attachment

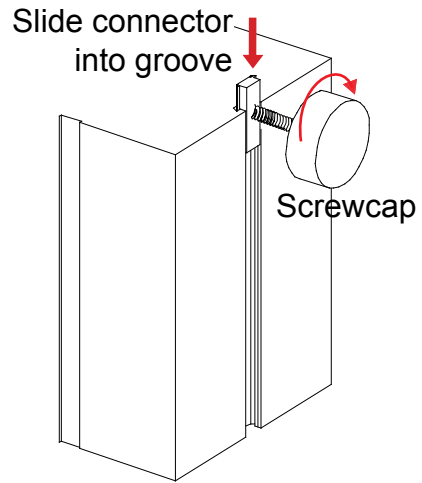

Slide connect into groove of extrusion from bottom. tighten cap to secure in place

WHEN DISASSEMBLING ALUMINUM EXTRUSION, TIGHTEN ALL SETSCREWS AND LOCKS TO PREVENT LOSS DURING SHIPPING

Steps:

- 1) Attach monitor mount to connects on upright where indicated.
- 2) Attach laptop box to upright where indicated.
- 3) Repeat steps for another upright.

Monitor Mount Attachment

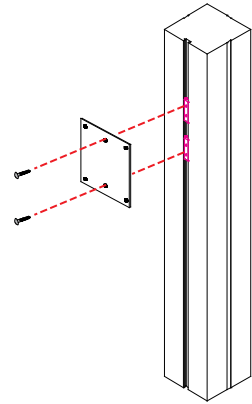

Attach back plate to connectors on vertical extrusion using screws. Then attach top plate and tighten setscrews to secure.

Laptop Box Attachment

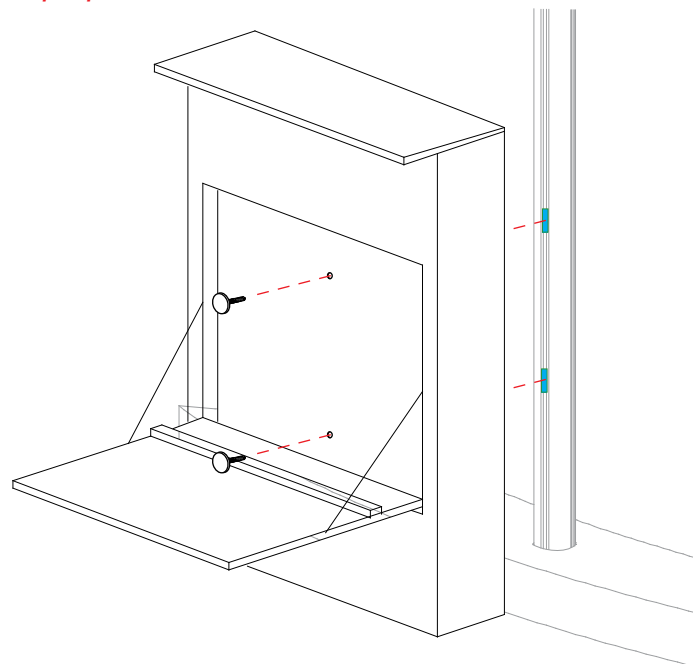

Remove screwcaps from connectors. Align holes on back of laptop box to hole on connectors. Then secure box to vertical using screw caps

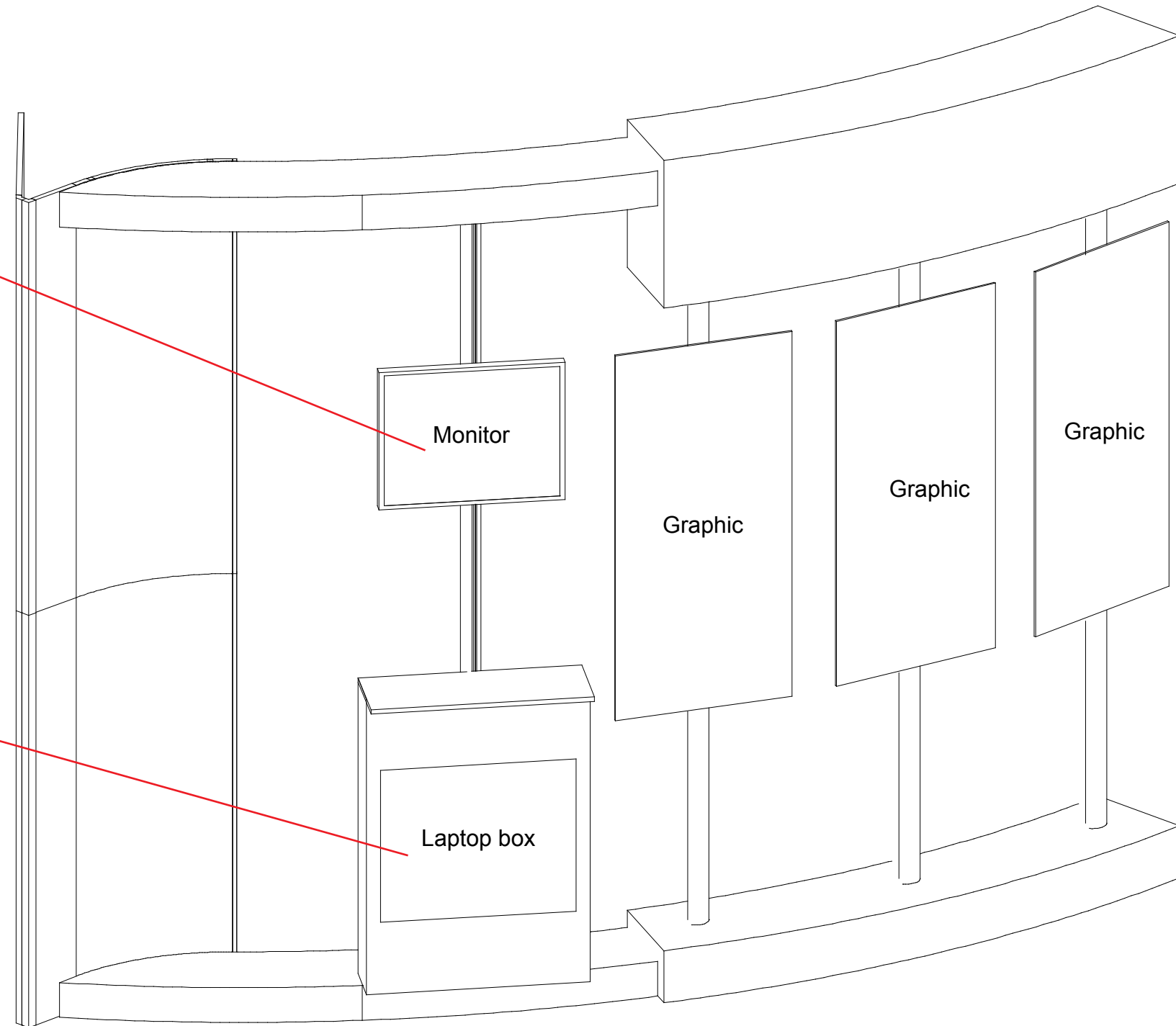

WHEN DISASSEMBLING ALUMINUM EXTRUSION, TIGHTEN ALL SETSCREWS AND LOCKS TO PREVENT LOSS DURING SHIPPING