

20'

20'

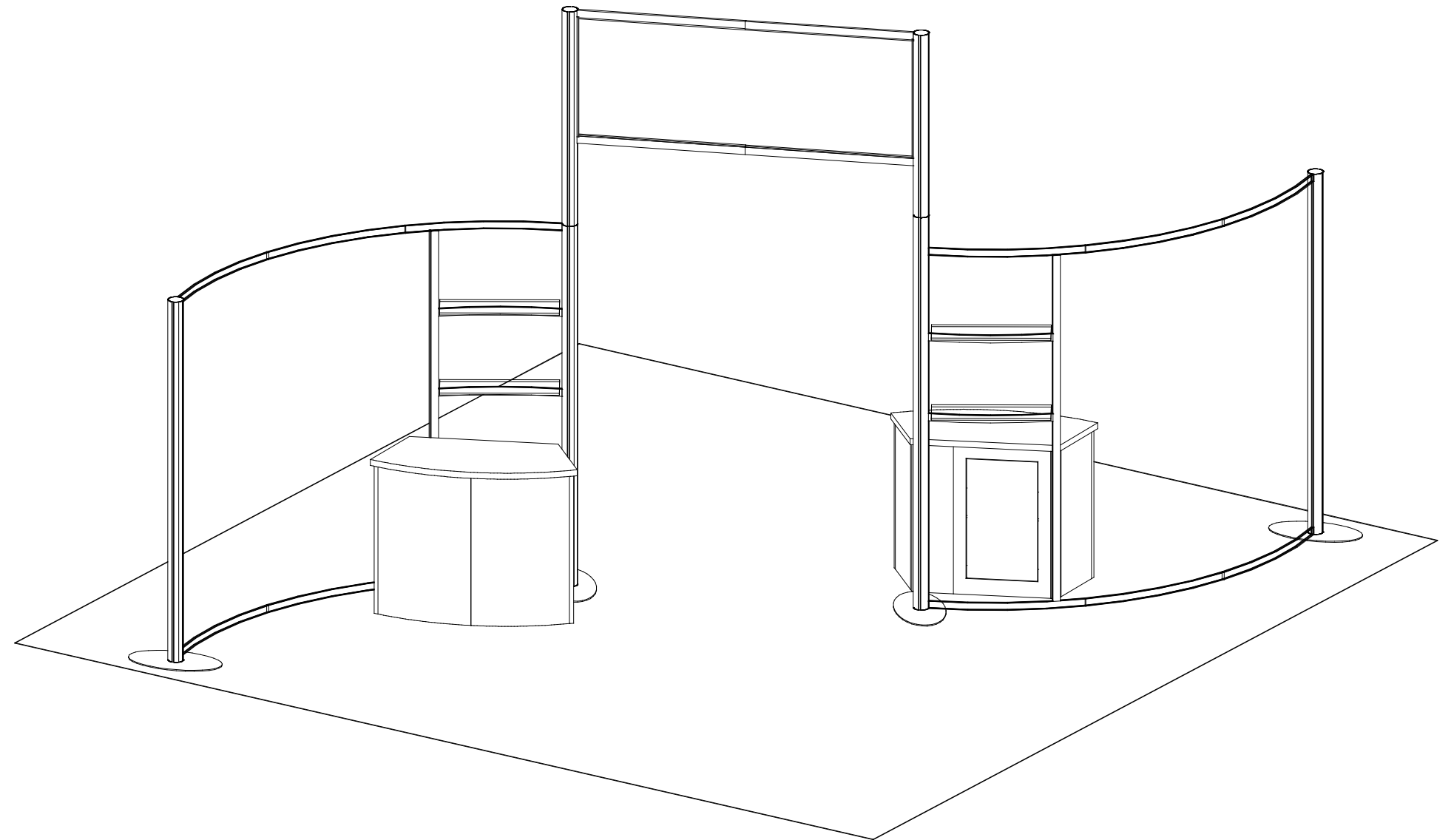

WHEN DISASSEMBLING ALUMINUM EXTRUSION, TIGHTEN ALL SETSCREWS AND LOCKS TO PREVENT LOSS DURING SHIPPING

euro It | HYBRIDS

Using Your Setup Instructions

The Euro LT Hybrids Setup Instructions are created specifically for your configuration. They are laid out sequentially in levels, including exploded views, and a logical series of detailed steps to assemble the main structure and components. We encourage you to study the instructions **before** attempting to assemble your exhibit.

Each page reminds you to tighten the setscrews after disassembling your exhibit to prevent loss of the locks and setscrews (see below in RED). This is VERY IMPORTANT.

Cleaning and Packing Your Display

- 1) Use care when cleaning aluminum extrusion or acrylic inserts. Use only non-abrasive cleaners.
- 2) When cleaning laminate inserts, countertops, or panels use mild cleansers and a soft material such as cotton.
- 3) Keep all display components away from extreme heat and long exposure to sunlight to avoid warping and fading.
- 4) Retain all packing material. It will make re-packing much easier and will reduce the likelihood of shipping damage.

General Setup Instructions for Panel System

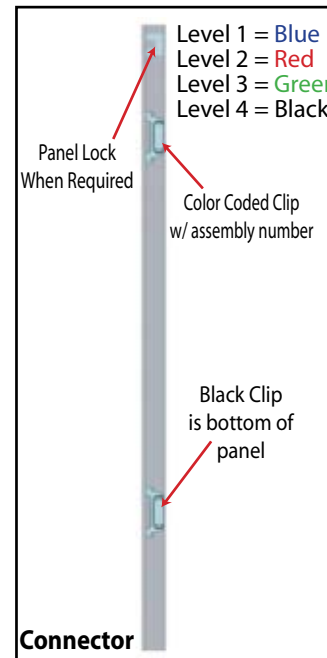

Each component has 2 clips, the lower clip is ALWAYS black. The top clip is color coded to distinguish the level. The color coded clip also contains the numbered label.

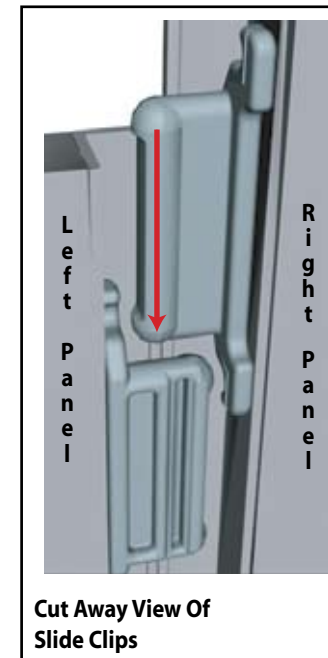

Components connect together by aligning them and sliding downward connecting clips together.

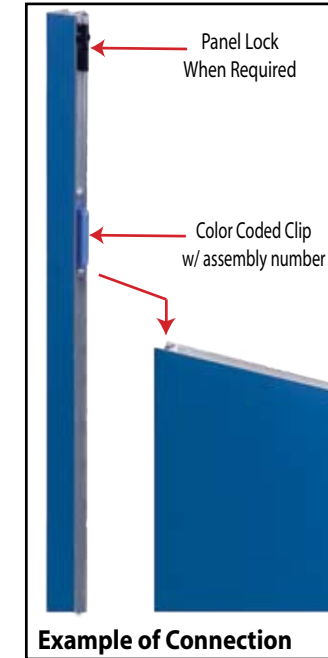

Configurations are assembled from left to right, usually starting with #1 and following the numbered sequence.

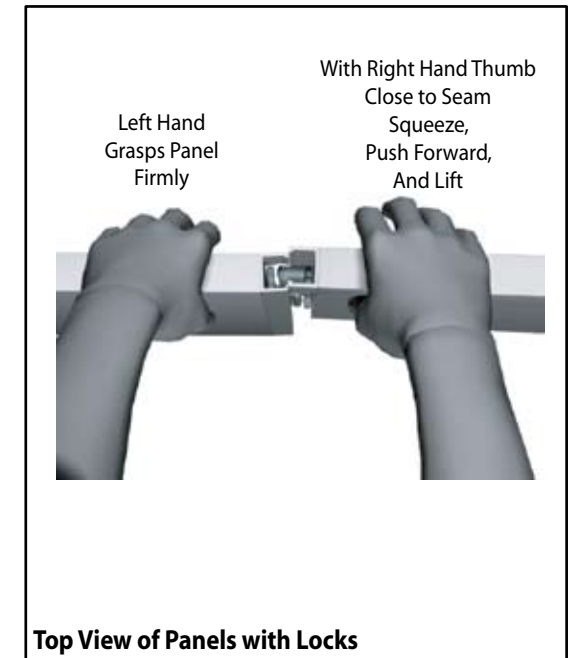

The first level of components contains panel locks that are located at the top of the panel for extra stability and a seamless connection. When disassembling panels, twist top connection slightly and lift right panel upward.

General Setup Instructions for Extrusion System



Most exhibits can be assembled with the supplied Hex Key Tool. Occasionally, a flat head screwdriver may be required.

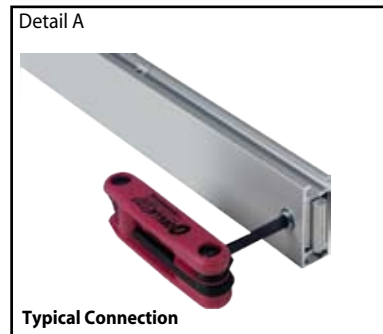

Most horizontal extrusion connections have a patented expandable lock. This lock inserts into the groove of an opposing extrusion. Tightening the lock with the Hex Key Tool expands the lock and creates a strong positive connection.

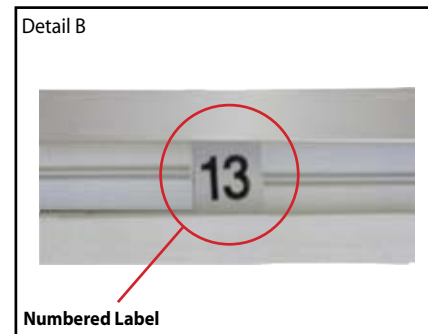

Each extrusion contains a numbered label which corresponds with setup instructions. The label is located within a groove of the extrusion (when possible).



Remove only (1) setscrew when disassembling. Replace setscrew in extrusion after assembling it. Before packing, replace setscrew in extrusion to avoid losing it.

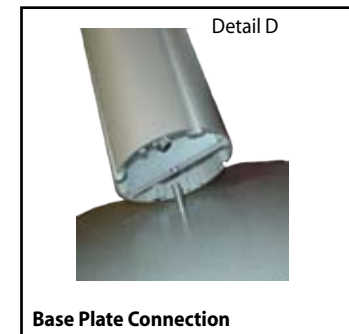

Attach base plate to round or square vertical extrusion using the bolt provided. Be careful not to strip the threads.

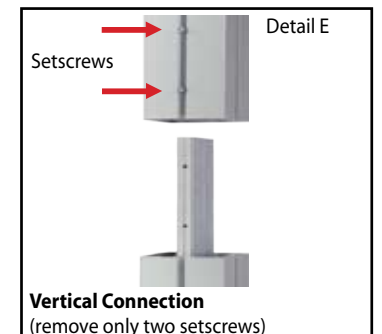

When vertical extrusions are packed in portable cases rather than crates or tubs, they must be broken down into smaller sections which then require assembly.

WHEN DISASSEMBLING ALUMINUM EXTRUSION, TIGHTEN ALL SETSCREWS AND LOCKS TO PREVENT LOSS DURING SHIPPING

Item	Qty.	Description
1	1	45"h Lower Vertical
2	1	45"h Upper Vertical
3	1	45"h Lower Vertical
4	1	45"h Middle Vertical
5	1	45"h Middle Vertical
6	1	8.28"h Upper Vertical
7	1	45"h Lower Vertical
8	1	45"h Middle Vertical
9	1	45"h Middle Vertical
10	1	8.28"h Upper Vertical
11	1	5"h Lower Vertical
12	1	45"h Upper Vertical
13a/14a	1/1	37.1927"w Curved Horizontal
13b/14b	1/1	43.3169"w Curved Horizontal
13c/14c	1/1	31.0685"w Curved Horizontal

- Steps:
- 1) Attach lower verticals to base plates.
 - 2) Connect vertical extrusions and horizontal extrusions together.
 - 3) Connect assembled horizontal extrusions with TSP extrusion highlighted in green between vertical assemblies as shown with opening groove facing forward, placing verticals [15/16 and 21/22] between horizontals.
 - 4) Connect horizontal assemblies [19a/19b and 20a/20b] between verticals as shown, sliding S12 extrusions into grooves between horizontal bars.
 - 5) Lock shelves with supports between verticals where indicated.

Item	Qty.	Description
15	1	43.204"h Vertical Extrusion
16	1	43.204"h Vertical Extrusion
17a/18a	1/1	31.0685"w Curved Horizontal
17b/18b	1/1	43.3169"w Curved Horizontal
17c/18c	1/1	37.1927"w Curved Horizontal
19a/19b	1/1	40"w Horizontal Extrusion
20a/20b	1/1	40"w Horizontal Extrusion
21	1	43.204"h Vertical Extrusion
22	1	43.204"h Vertical Extrusion
23	1	29.2768"w Shelf Support

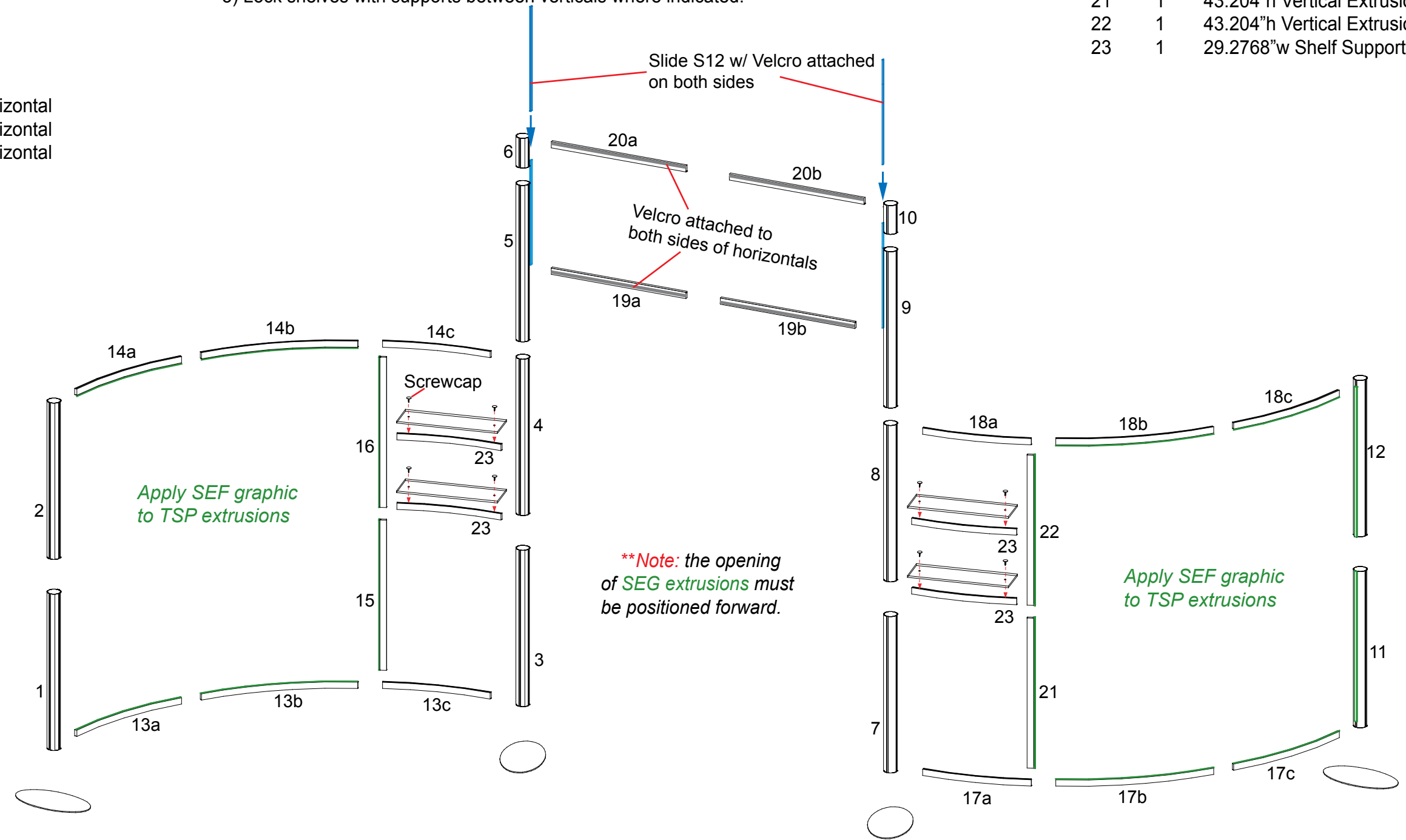
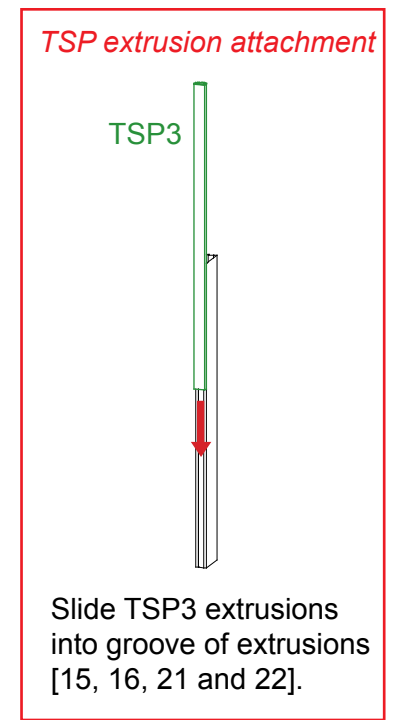

WHEN DISASSEMBLING ALUMINUM EXTRUSION, TIGHTEN ALL SETSCREWS AND LOCKS TO PREVENT LOSS DURING SHIPPING

866.652.2100

Item Number	Description
1	16.25" w x 38" h Panel
2	38" h Flexible Connector
3	23" w x 38" h Panel w/ Door
4	6.625" w x 38" h Panel
5	38" h Flexible Connector
6	16.25" w x 38" h Panel
7	38" h 90° Connector
8	57.5" r Curved Panel
9	57.5" r Curved Panel
10	38" h 90° Connector

- Steps:
- 1) Assemble by starting at panel #1 and continue in numerical order.
 - 2) Velcro internal shelf supports to inside of assembled base.
 - 3) Set internal shelf atop shelf supports.
 - 4) Place counter atop assembled pedestal base.

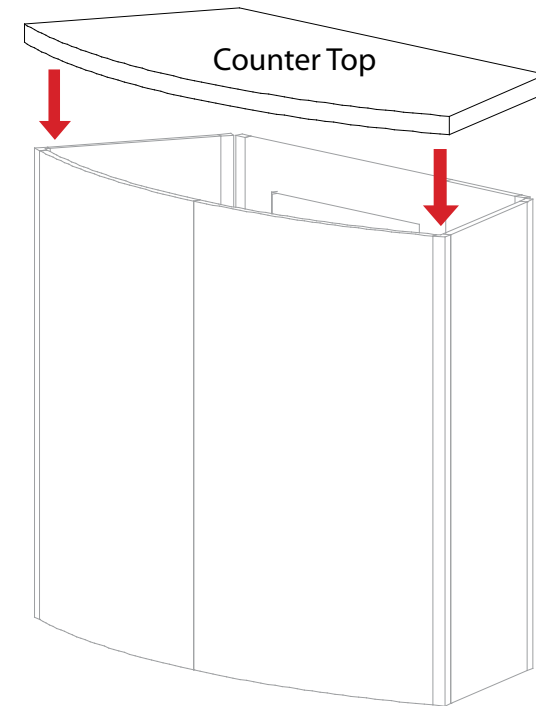
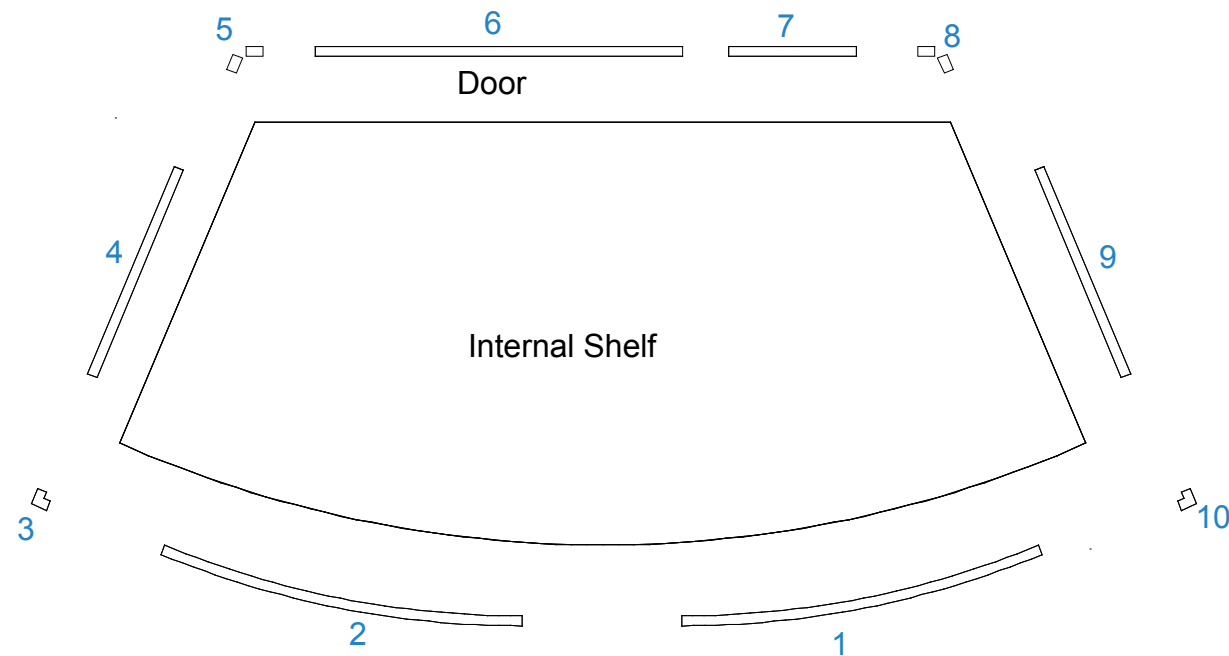
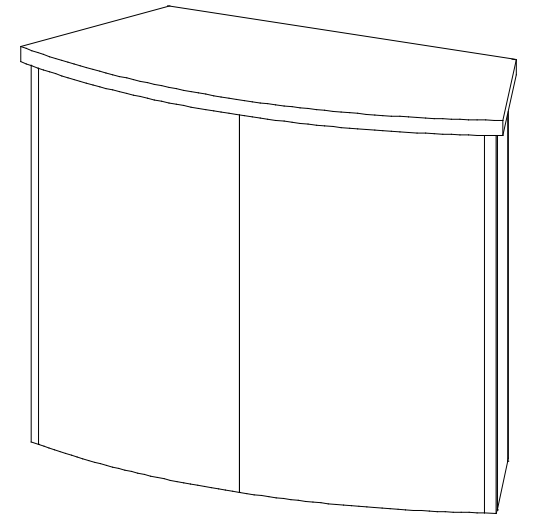

Place counter atop assembled pedestal base.

WHEN DISASSEMBLING ALUMINUM EXTRUSION, TIGHTEN ALL SETSCREWS AND LOCKS TO PREVENT LOSS DURING SHIPPING

866.652.2100



Using Your Setup Instructions

The Aero Overhead Sign Setup Instructions are created specifically for your configuration. They include an exploded view of the frame which is sequentially numbered. We encourage you to study the instructions before attempting to assemble your exhibit.

Connections are kept very simple: no tools. Everything assembles with push-button connectors and pre-connected horizontal sections.

Cleaning and Packing Your Display

- 1) Use care when cleaning aluminum extrusion or acrylic inserts. Use only non-abrasive cleaners.
- 2) Retain all packing material. It will make re-packing much easier and will reduce the likelihood of shipping damage.

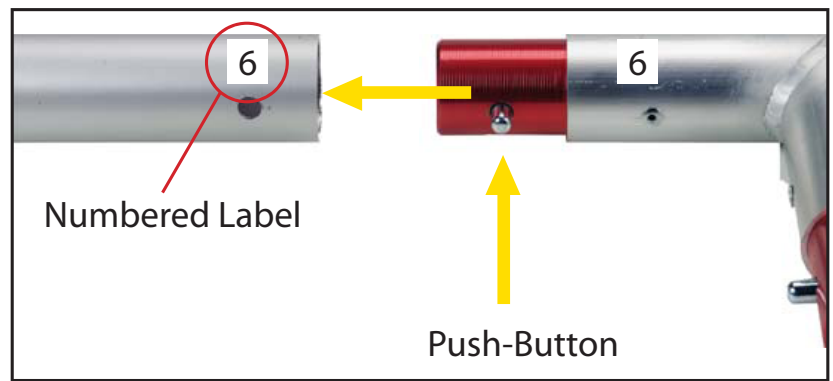
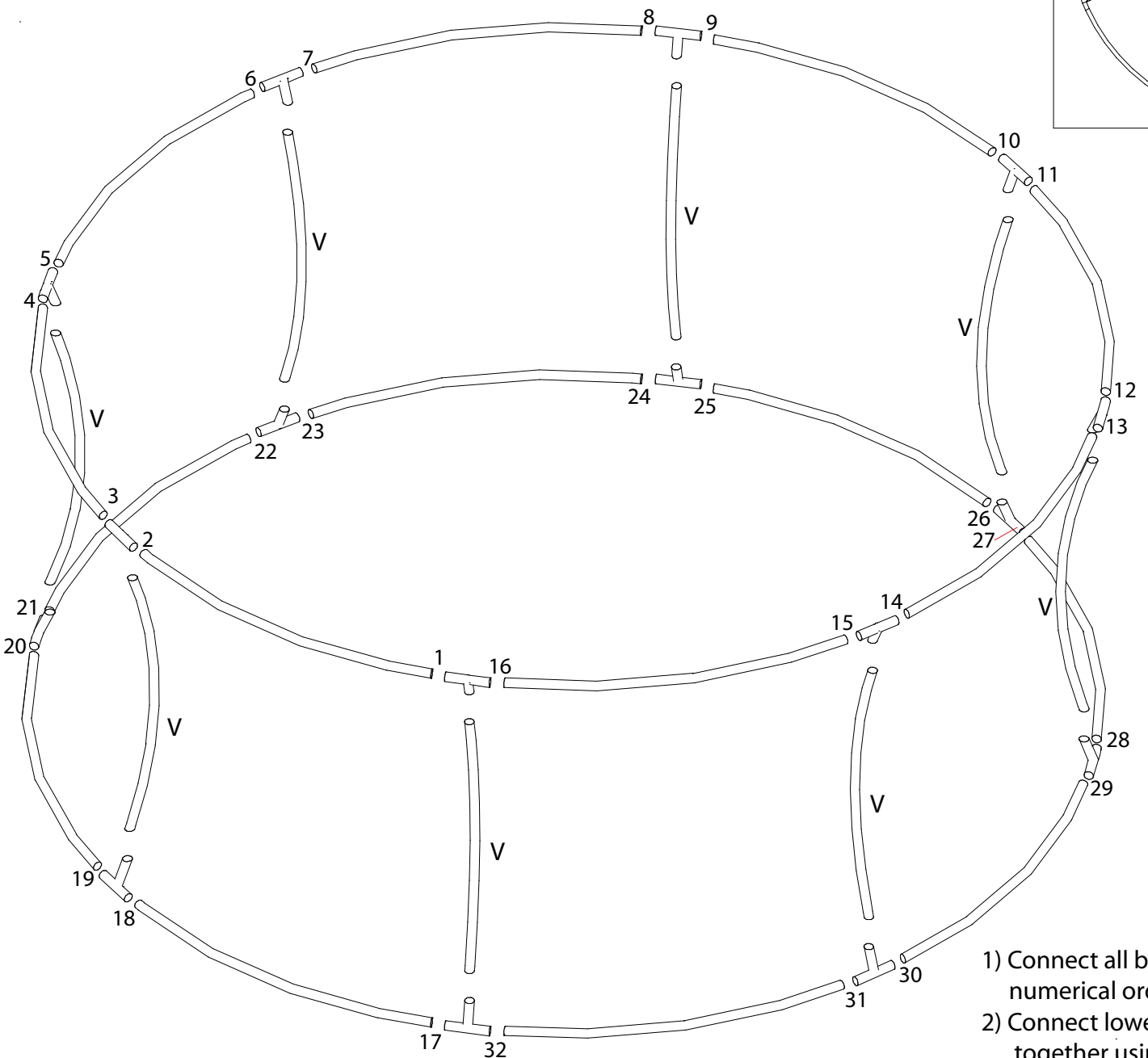
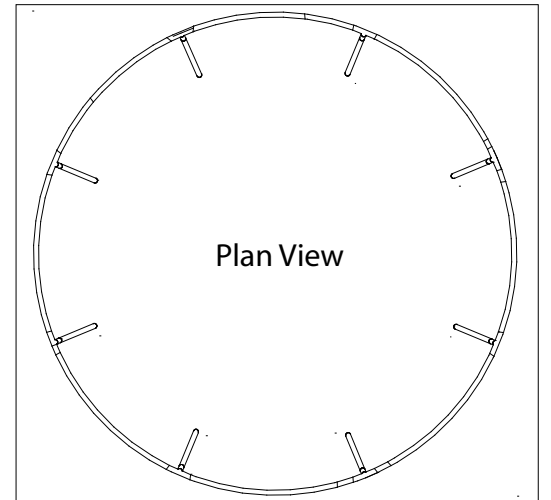

Connections are made by holding the button down and sliding the red tube into opposing tube until the connection is made. To disassemble push button and pull or twist extrusions apart.

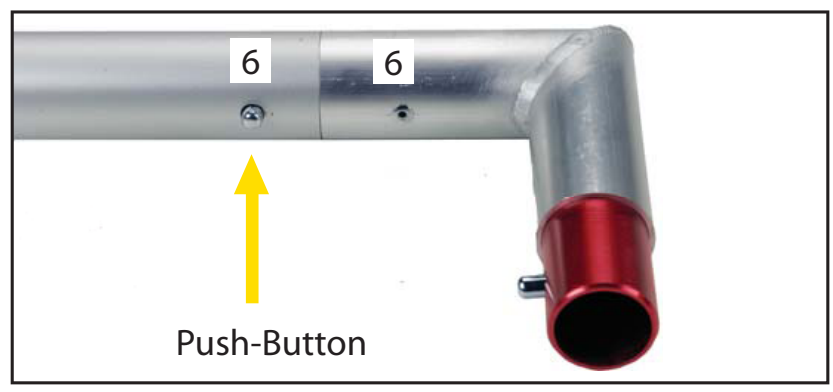

- 1) Connect all bungied pieces together in numerical order.
- 2) Connect lower section and upper section together using (8) Vertical Supports.

WHEN DISASSEMBLING ALUMINUM EXTRUSION, TIGHTEN ALL SETSCREWS AND LOCKS TO PREVENT LOSS DURING SHIPPING

Top view of each level

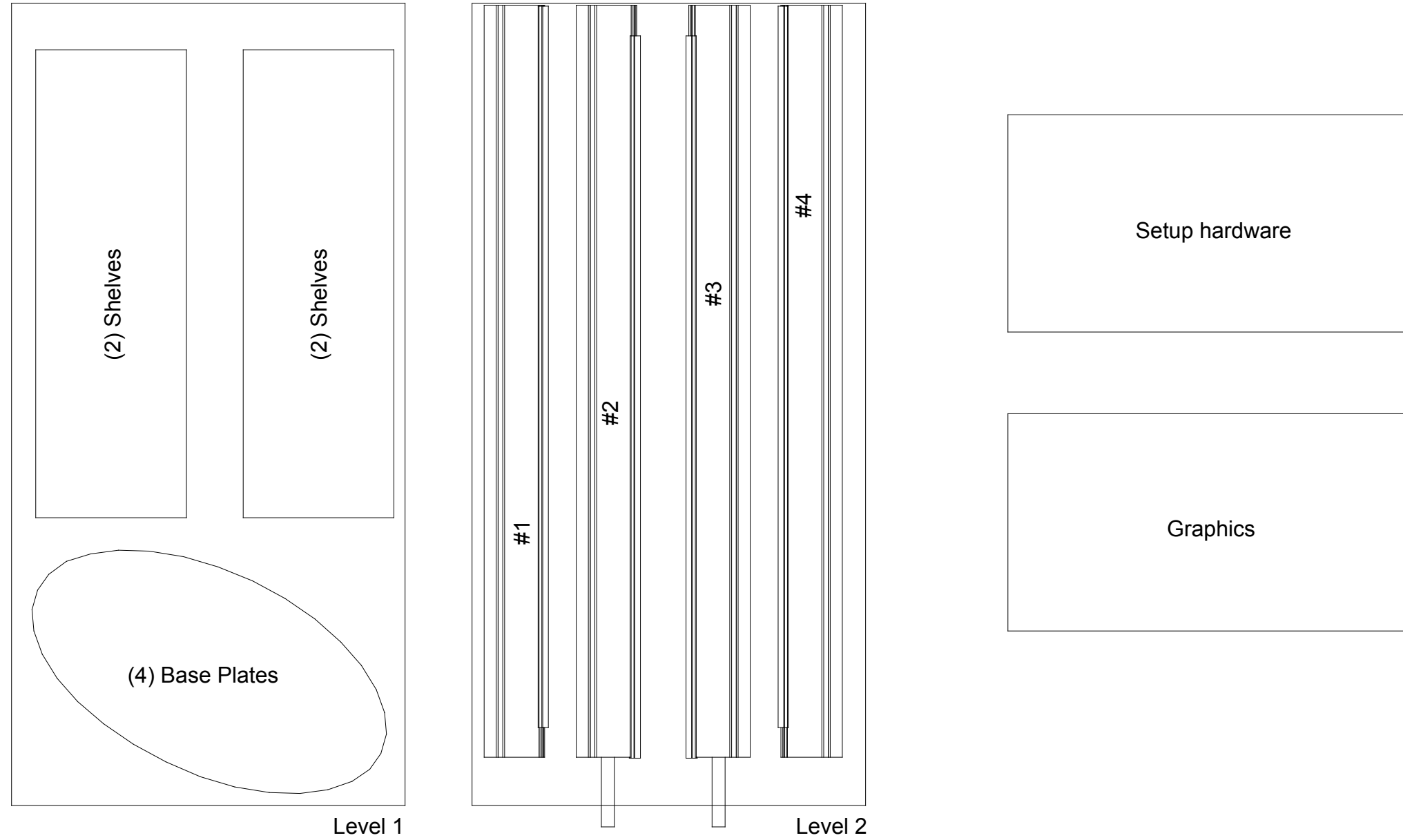

WHEN DISASSEMBLING ALUMINUM EXTRUSION, TIGHTEN ALL SETSCREWS AND LOCKS TO PREVENT LOSS DURING SHIPPING

Top view of each level

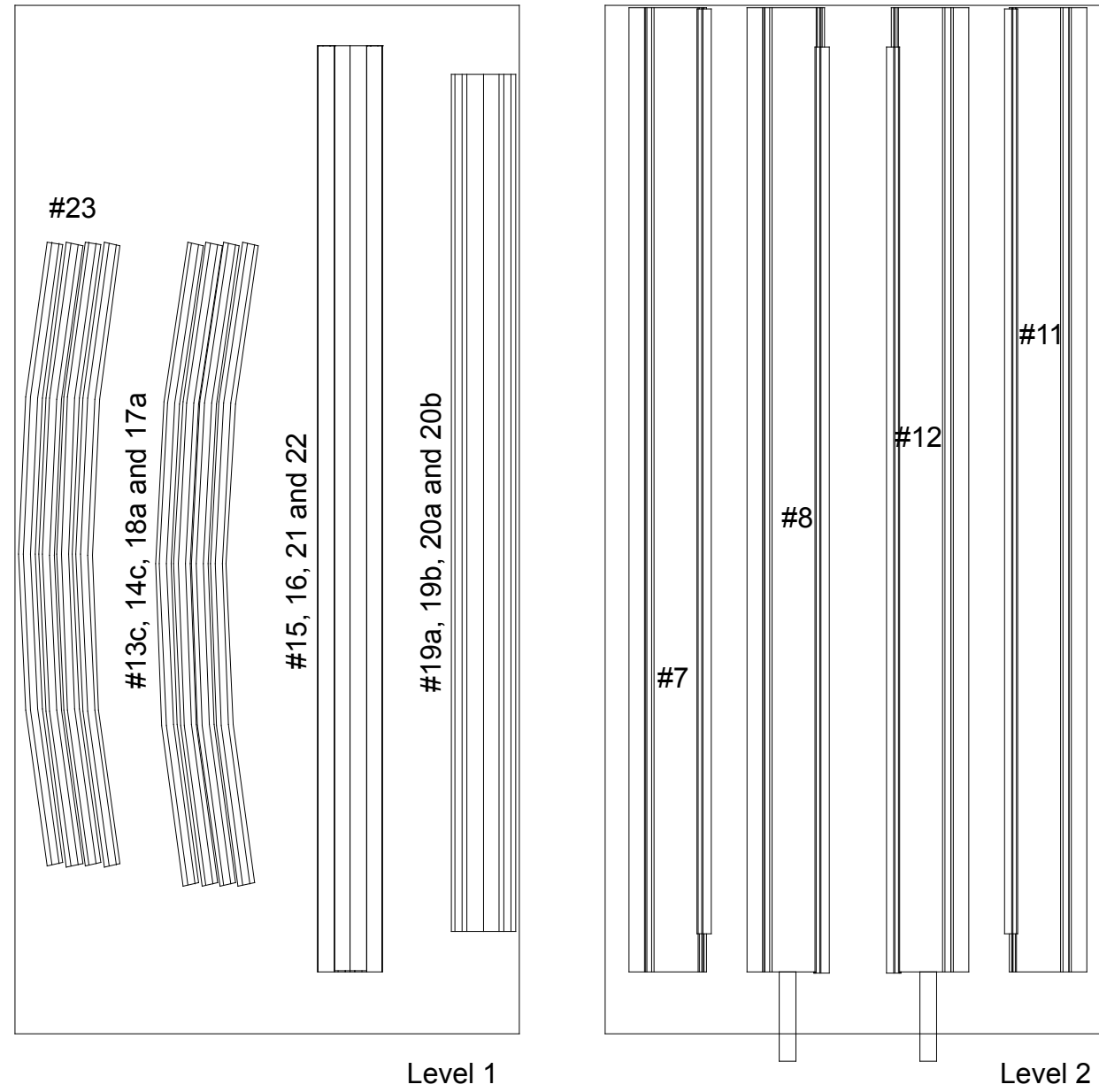

WHEN DISASSEMBLING ALUMINUM EXTRUSION, TIGHTEN ALL SETSCREWS AND LOCKS TO PREVENT LOSS DURING SHIPPING

Top view of each level

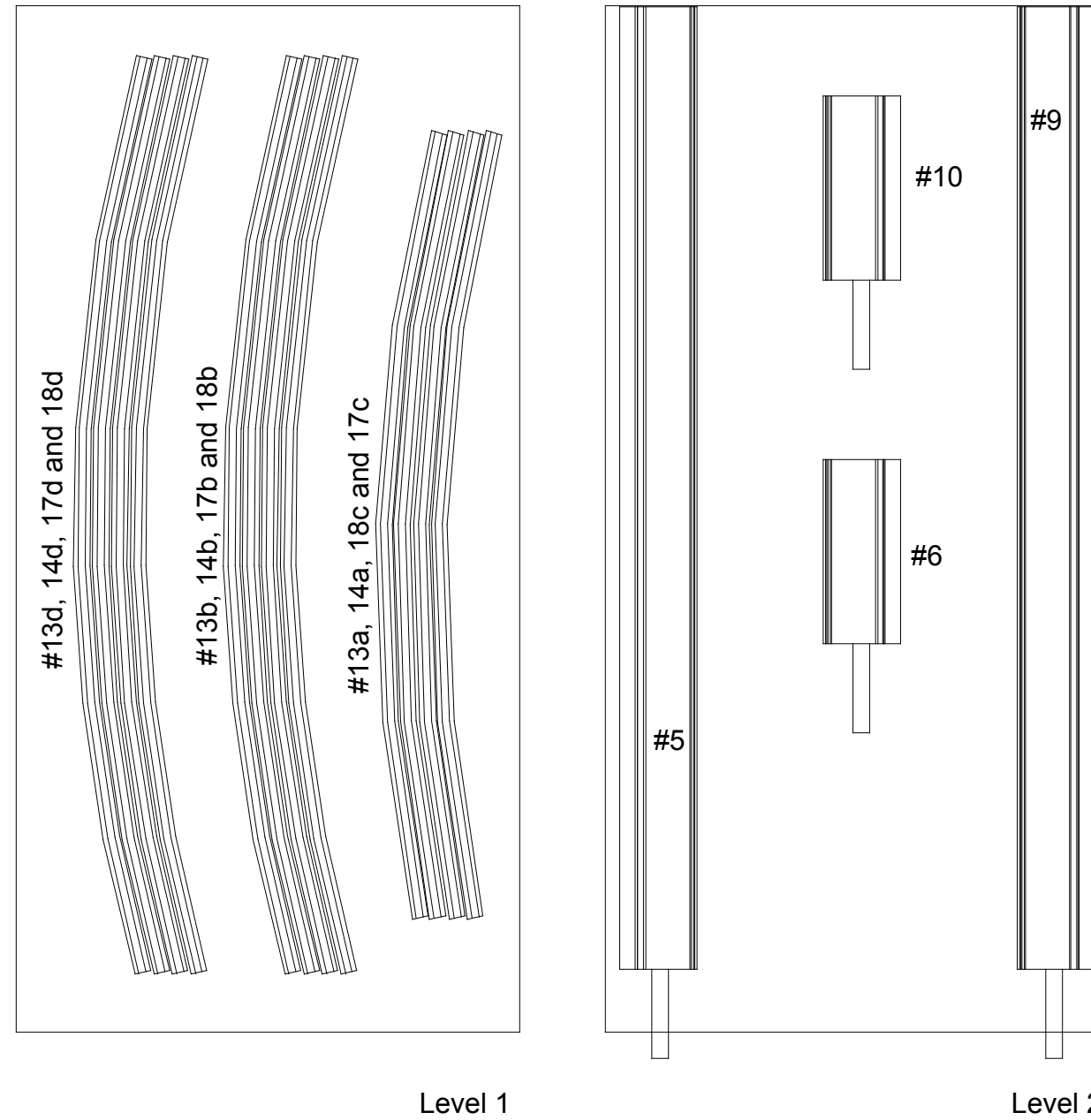

WHEN DISASSEMBLING ALUMINUM EXTRUSION, TIGHTEN ALL SETSCREWS AND LOCKS TO PREVENT LOSS DURING SHIPPING

Top view of each level

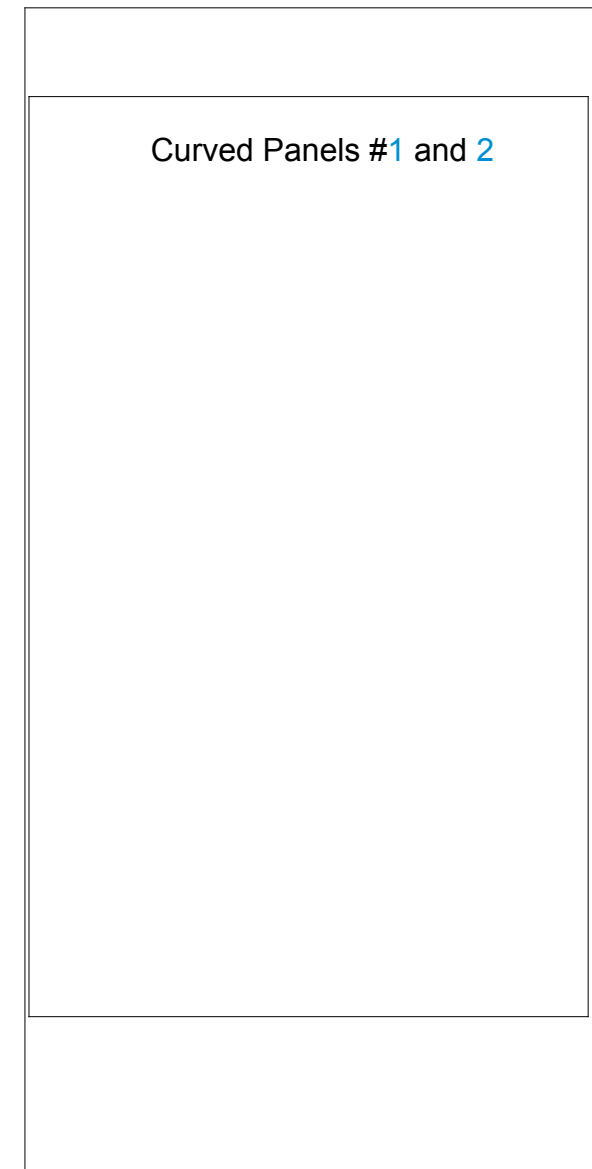
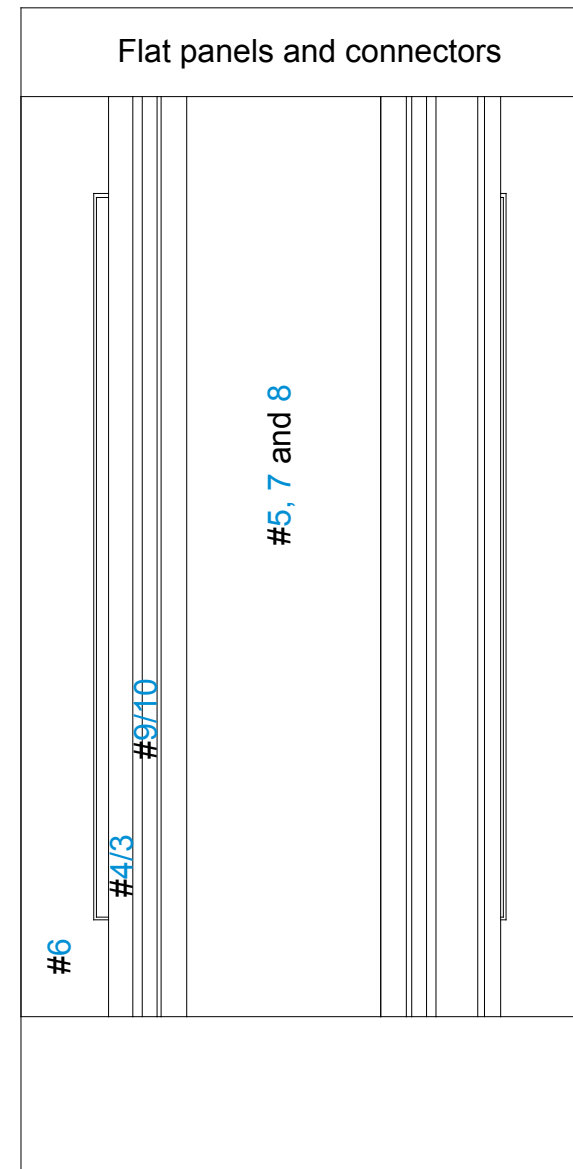
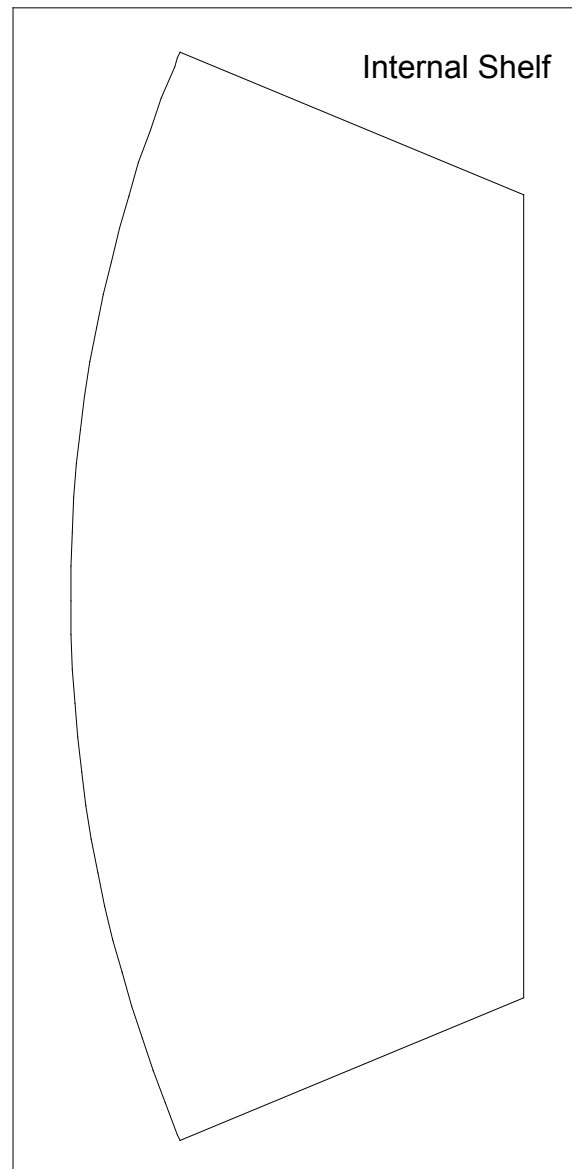
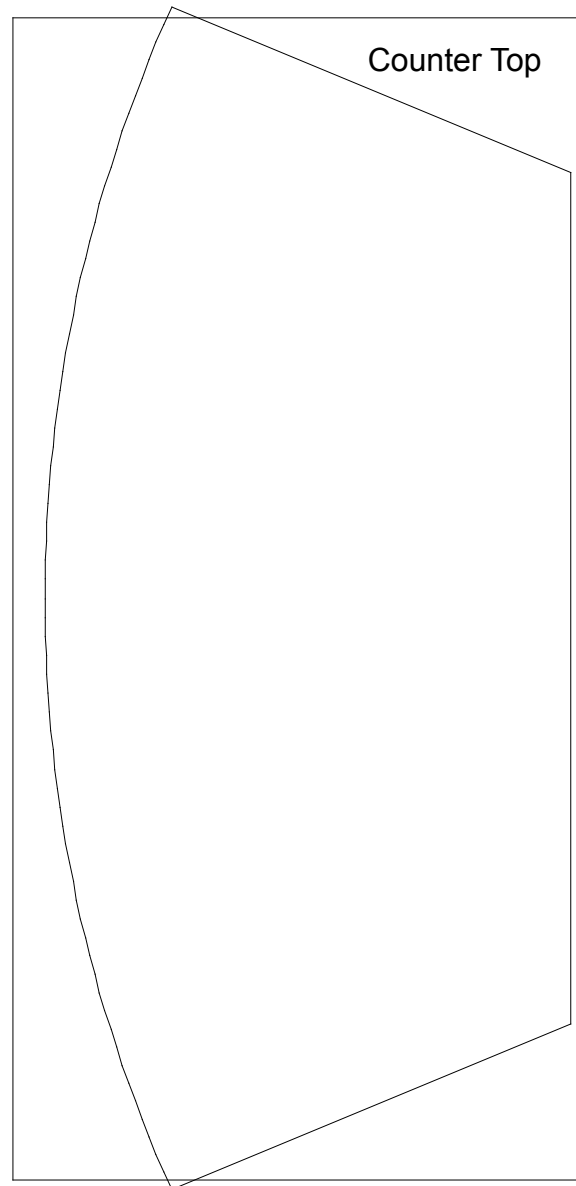

WHEN DISASSEMBLING ALUMINUM EXTRUSION, TIGHTEN ALL SETSCREWS AND LOCKS TO PREVENT LOSS DURING SHIPPING

Top view of each level

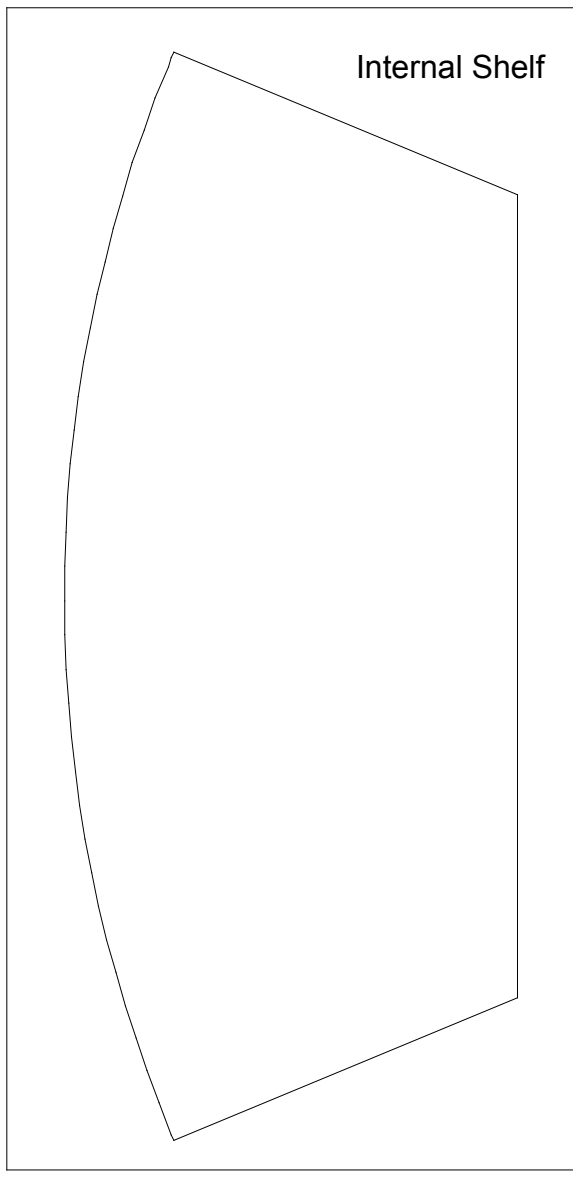
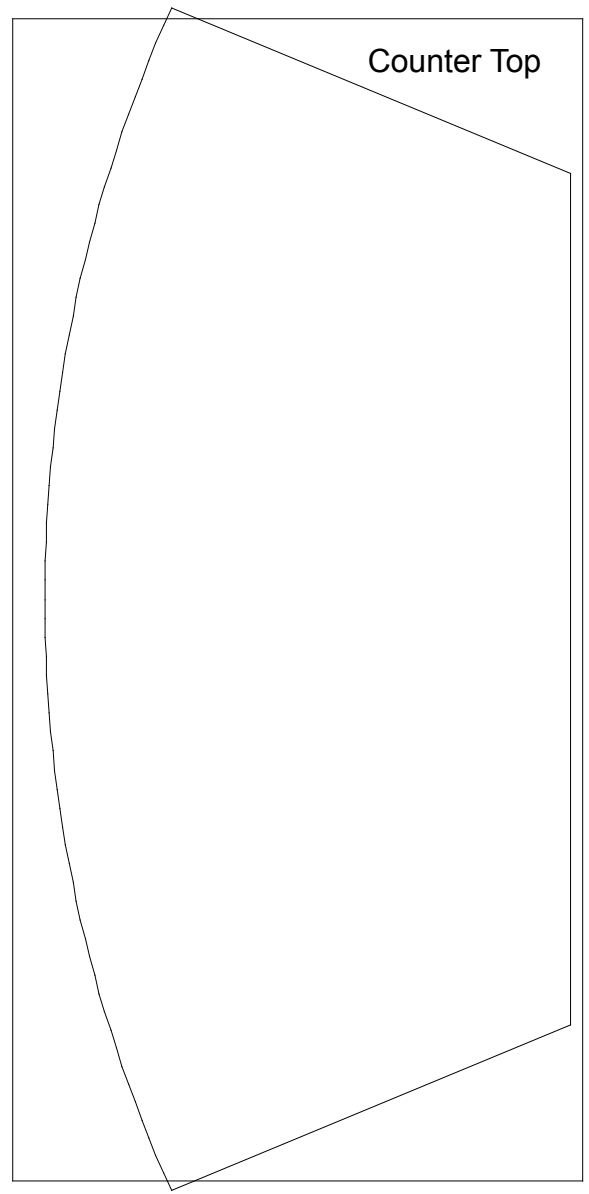

Level 1

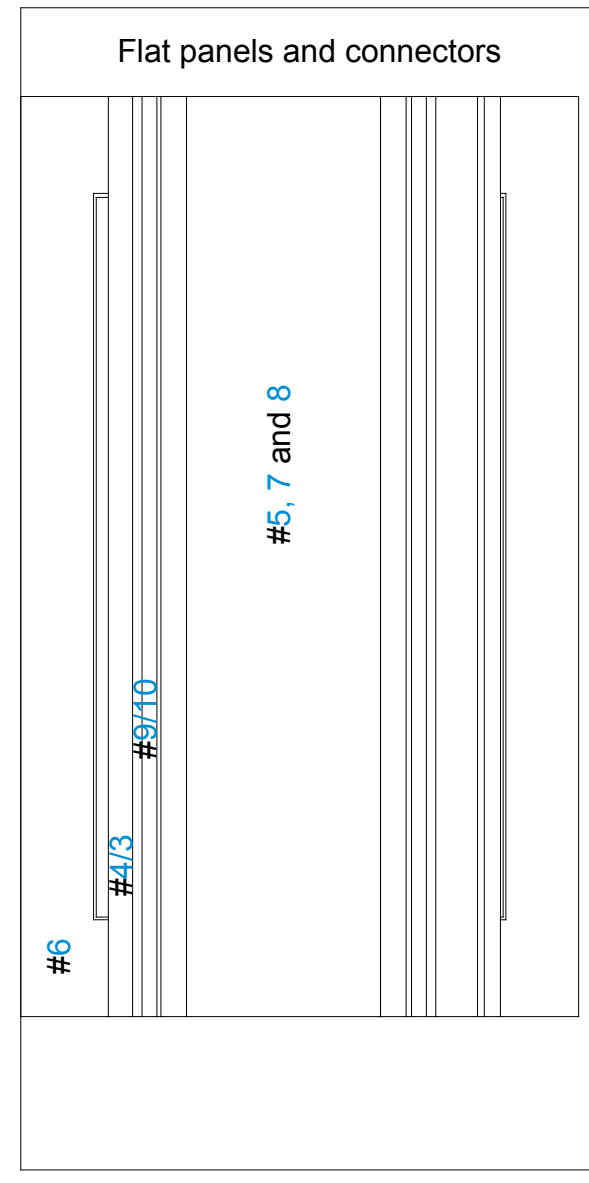

Level 2

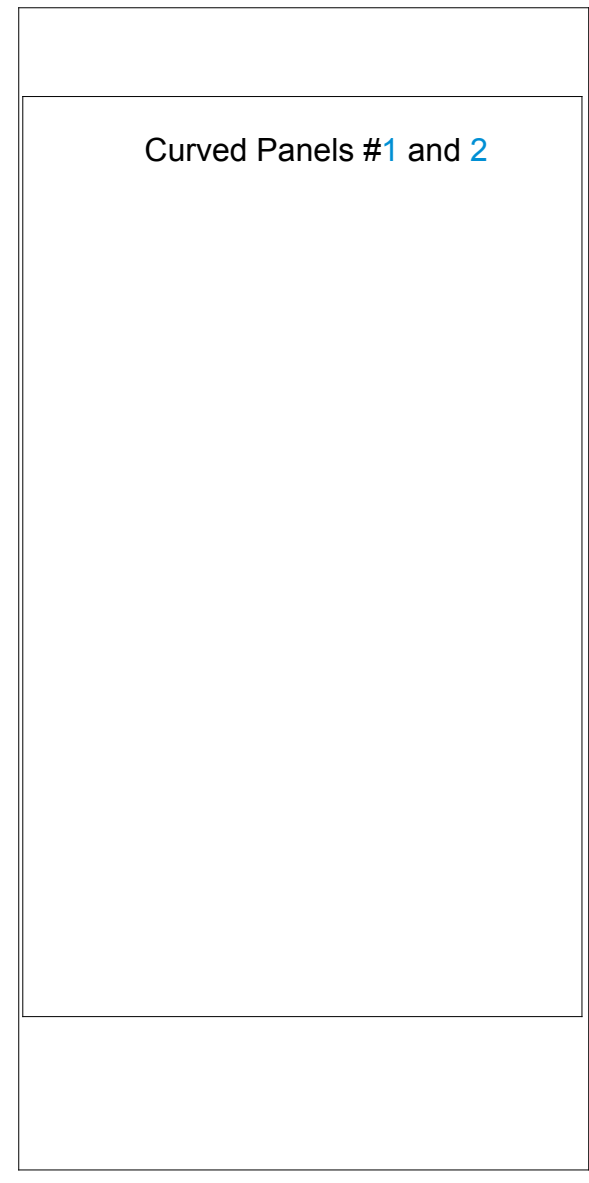

WHEN DISASSEMBLING ALUMINUM EXTRUSION, TIGHTEN ALL SETSCREWS AND LOCKS TO PREVENT LOSS DURING SHIPPING

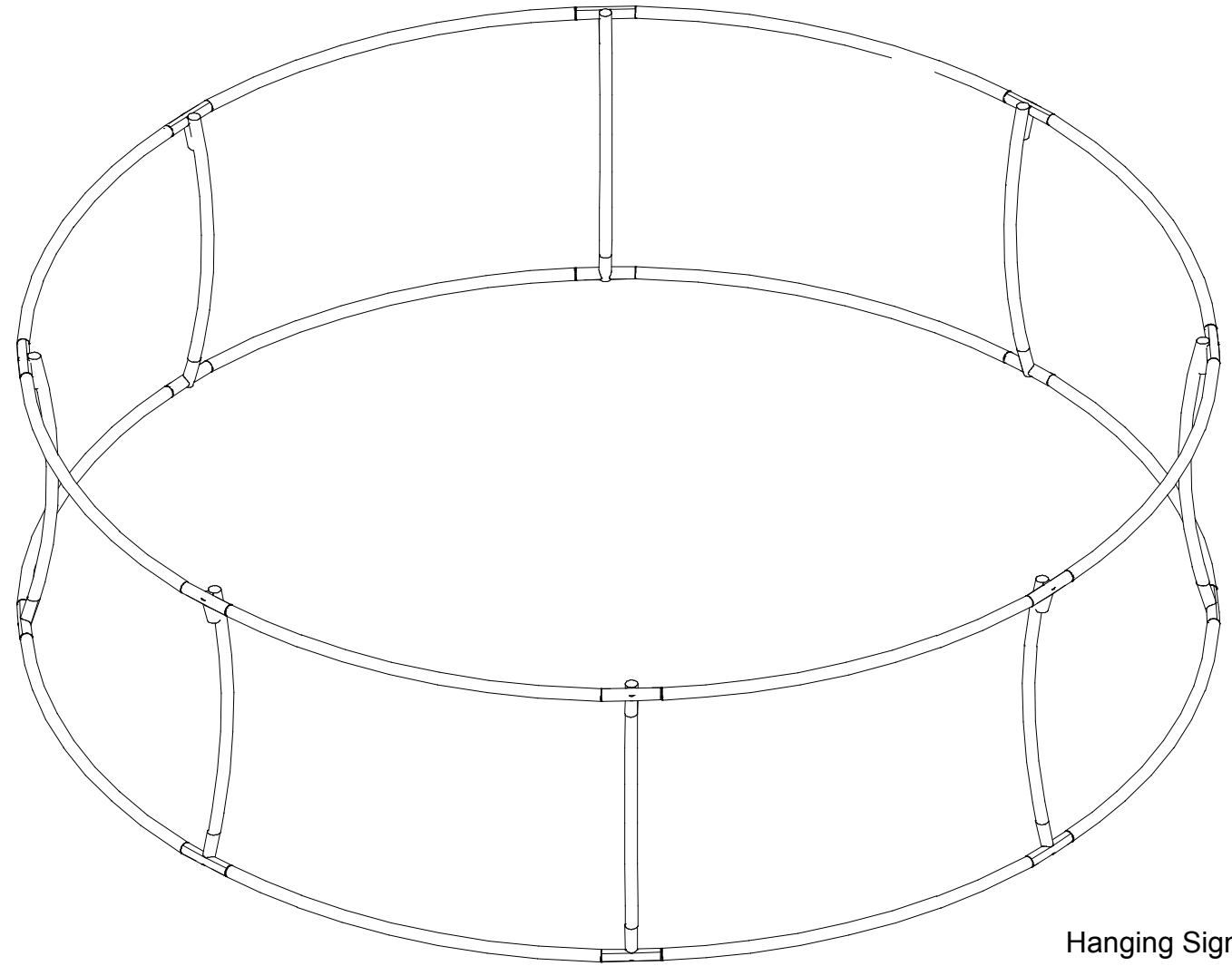

WHEN DISASSEMBLING ALUMINUM EXTRUSION, TIGHTEN ALL SETSCREWS AND LOCKS TO PREVENT LOSS DURING SHIPPING