

Perfect 10 Hybrid Displays

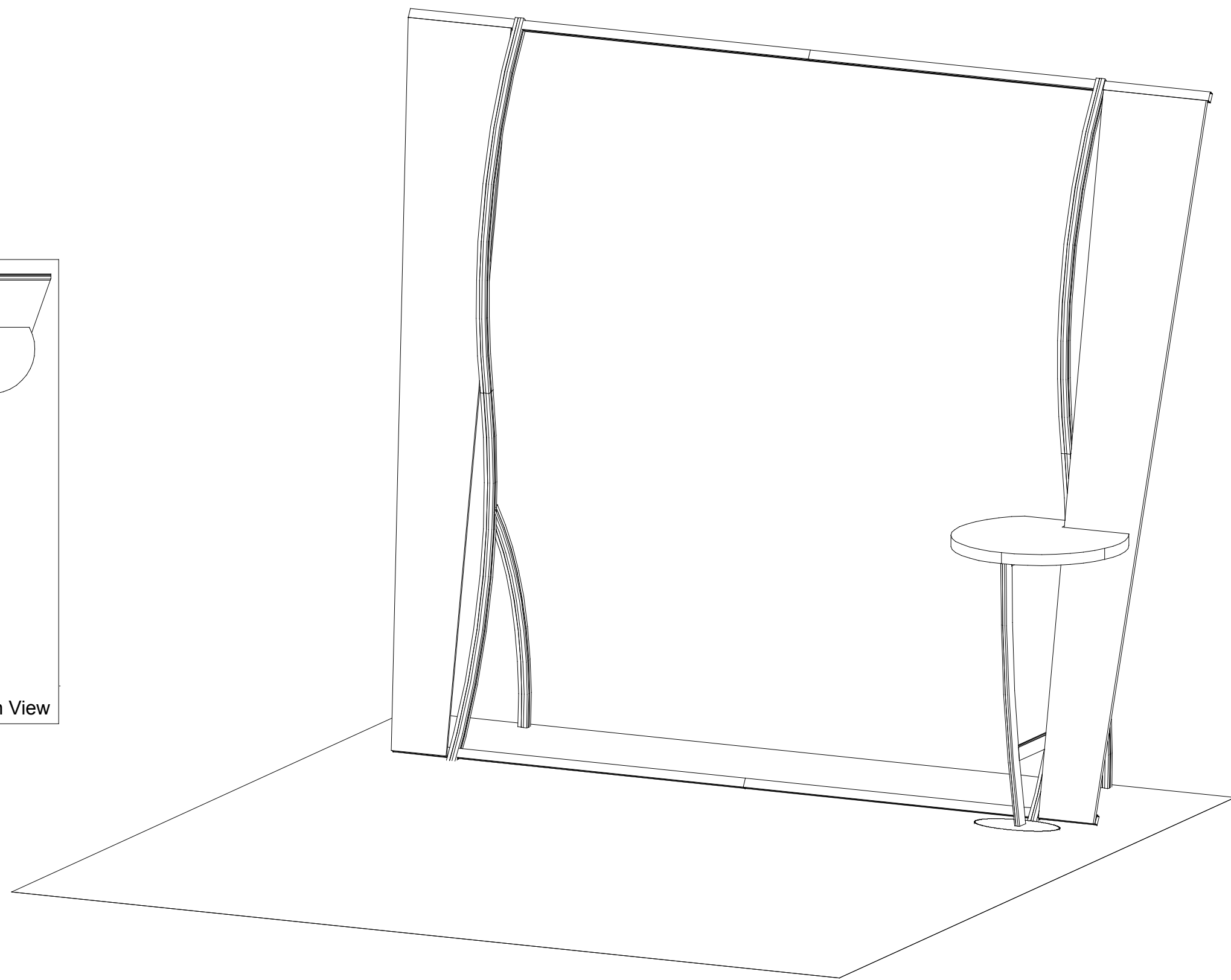
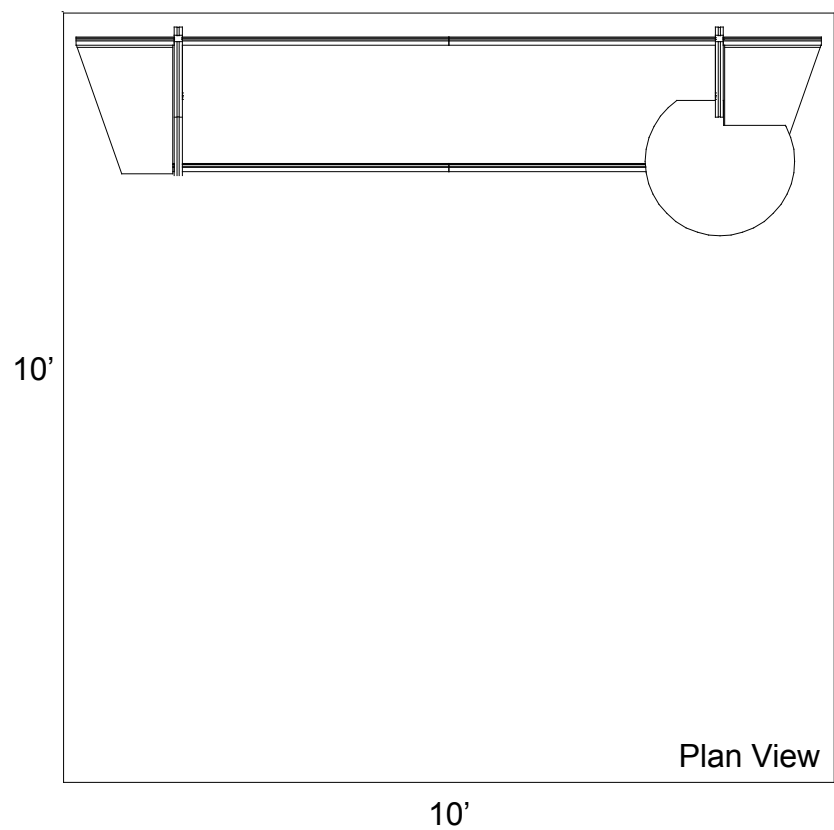

WHEN DISASSEMBLING TIGHTEN ALL KNOBS TO PREVENT LOSS DURING SHIPPING

866.652.2100

Part Number	Description
1	Left Leg Assembly
2	Right Leg Assembly
3	Upper Curved Vertical
4	Upper Curved Vertical
5	83" w Horizontal w/ Hinge Facing UP
6	83" w Horizontal w/ Hinge Facing DOWN
11	8.25" w Horizontal Bar
12	15.25" w Horizontal Bar

Step 1

Step 1:

NOTE: Can be assembled either face down on floor then lifted upright or upright as shown in drawings.

- A) Connect leg assemblies [1 and 2] using horizontal bar [5].
- B) Connect vertical extrusion [3 and 4] to leg assemblies [1 and 2] using vertical connection bars as shown.
- C) Connect horizontal extrusion [6] between vertical assemblies by tightening BLACK knobs on backside of extrusion making sure Velcro faces toward BACK.
- D) Connect horizontal extrusions [11 and 12] to both sides of assembled backwall as shown.

NOTE: Make sure the lock is flush with extrusion before tightening. If lock will not fully engage, gently rock lock and extrusion while turning knob until lock fully opens.

NOTE: When assembling horizontals they should be placed approximately one inch from TOP and BOTTOM.

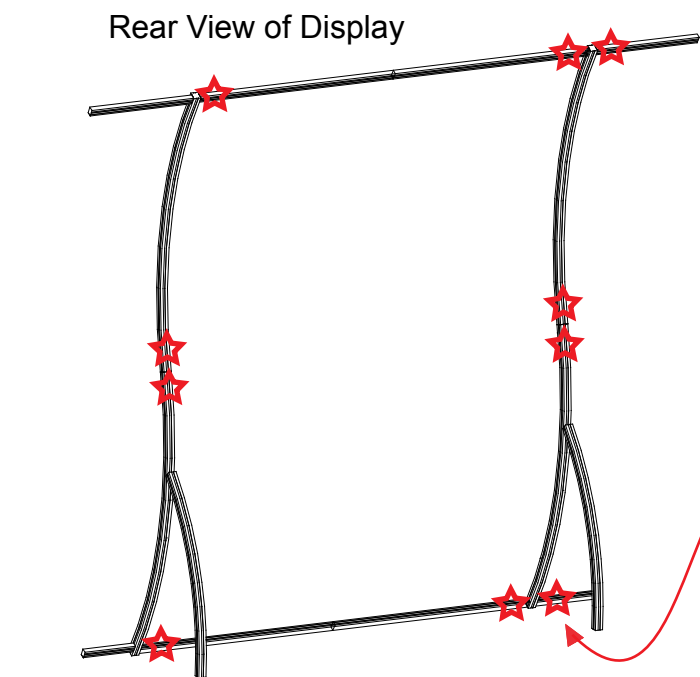

STAR indicates location of knobs on BACKSIDE of unit.

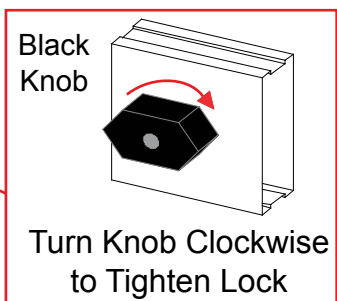

Slide Connection Bar into lower leg assembly. Slide upper vertical over bar and secure both.

WHEN DISASSEMBLING TIGHTEN ALL KNOBS TO PREVENT LOSS DURING SHIPPING

Part Number	Qty	Description
7	1	15.69"w Horizontal Extrusion
8	1	18.5"w Horizontal Extrusion
9	1	37.6"h Curved Vertical Extrusion
9a	1	Oval Flange Plate
10	1	Base Plate

Steps

- 1) Attach counter support assembly to assembled backwall where indicated.
- 2) Attach flange plate to top of vertical [9] as shown.
- 3) Place counter top on assembled counter support, see Counter Attachment detail.
- 4) Attach monitor mount to assembled backwall.
- 5) Slide graphics on horizontal bars.

866.652.2100

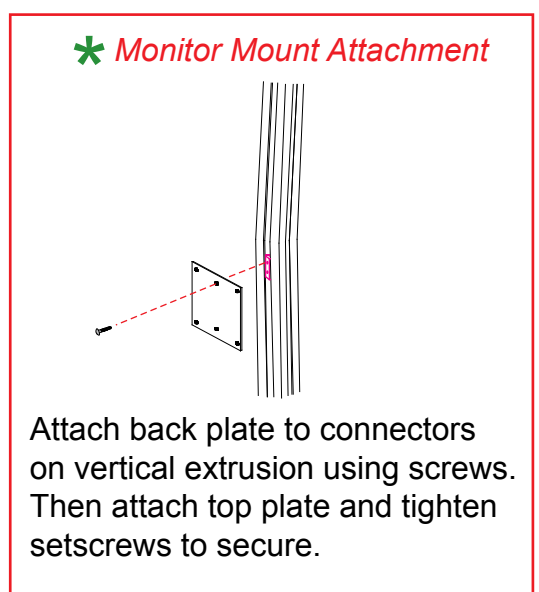
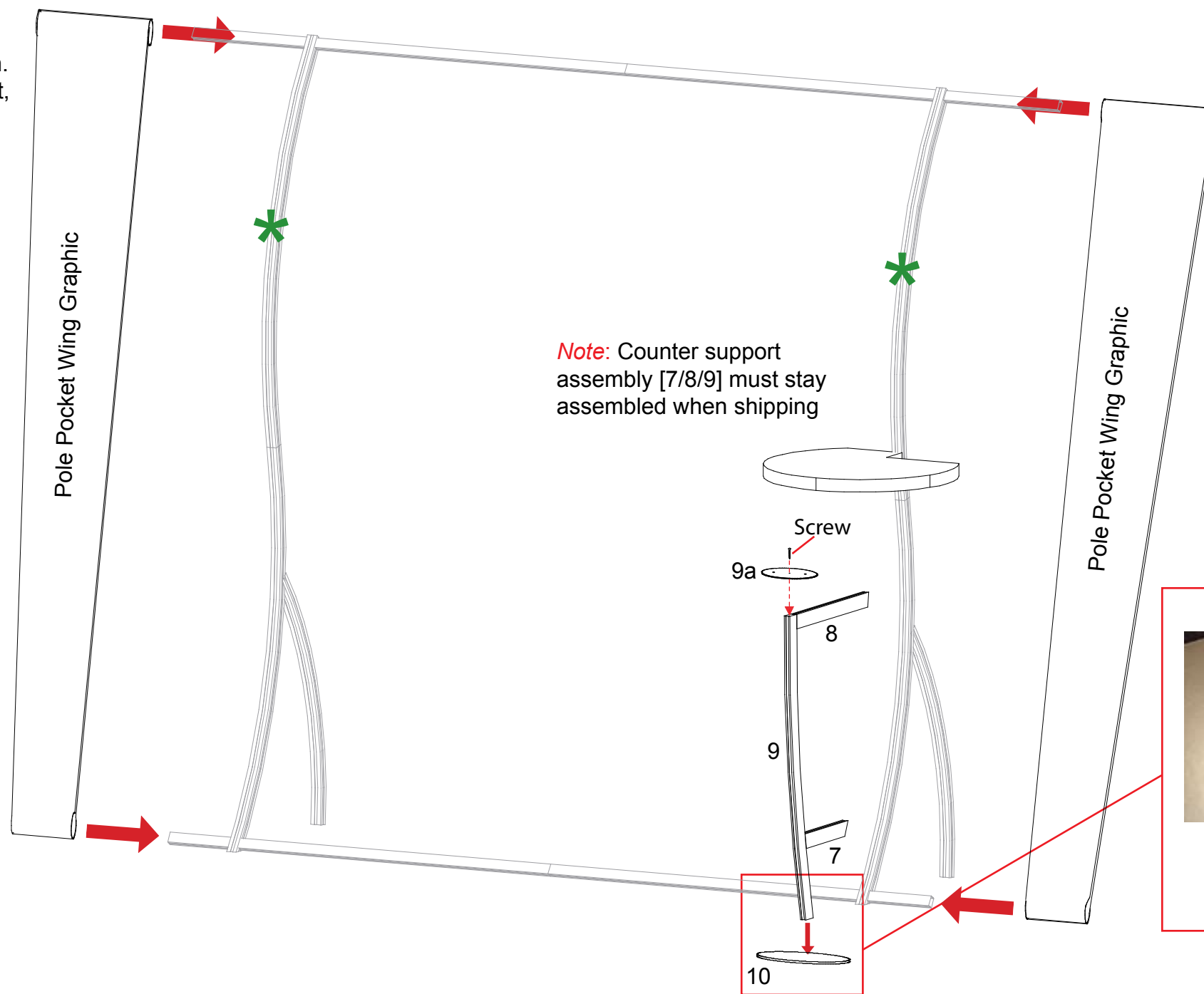
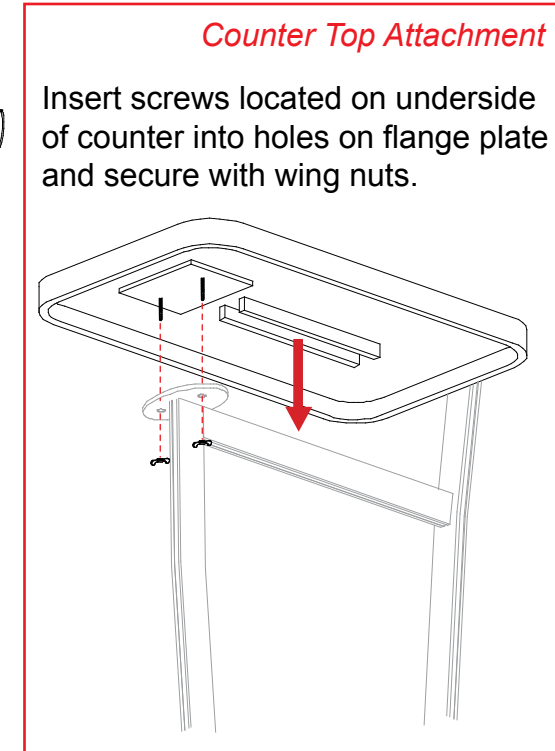
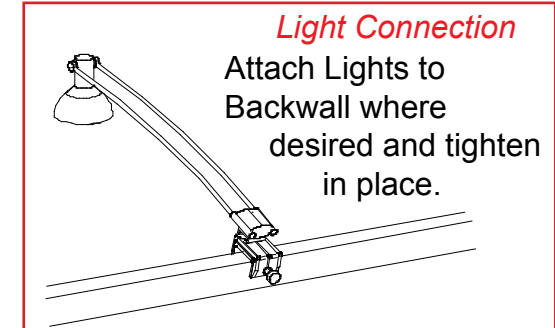

WHEN DISASSEMBLING TIGHTEN ALL KNOBS TO PREVENT LOSS DURING SHIPPING

Top View of each Level

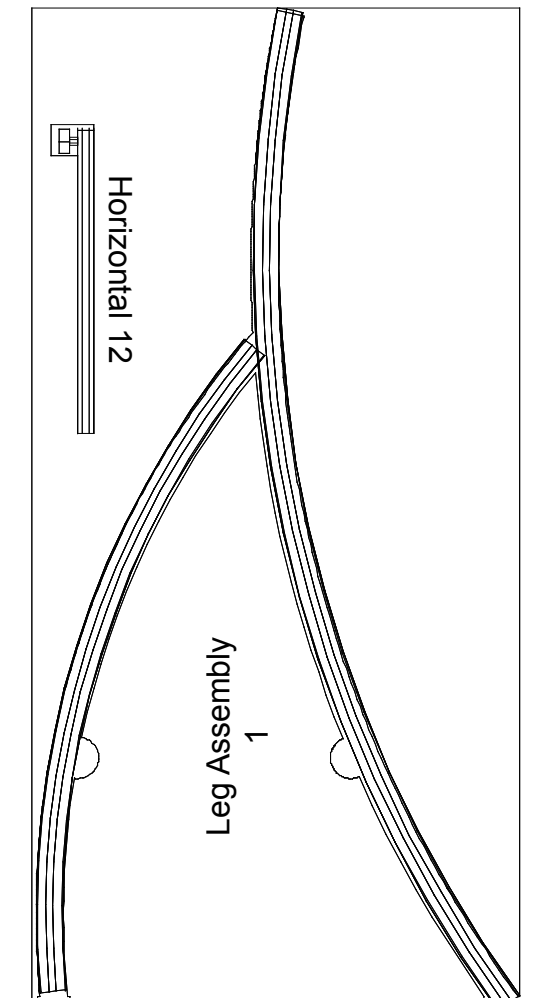
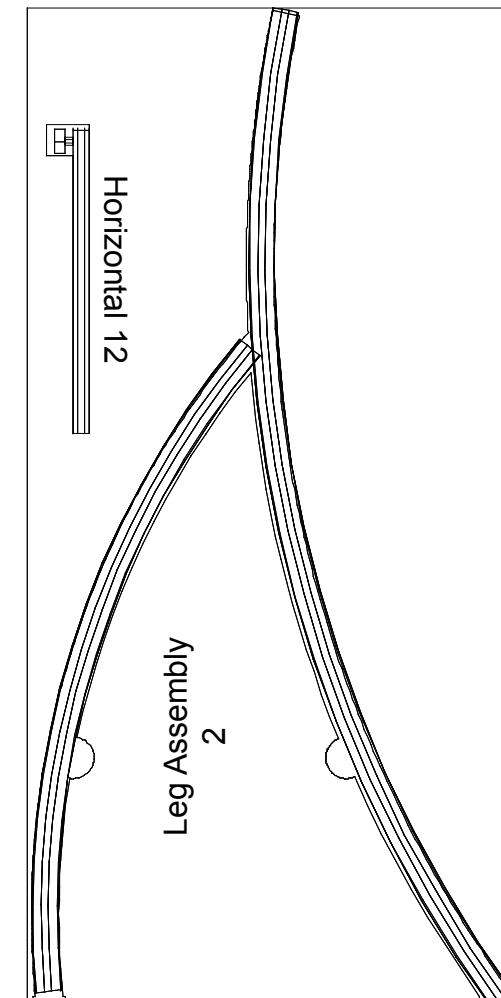
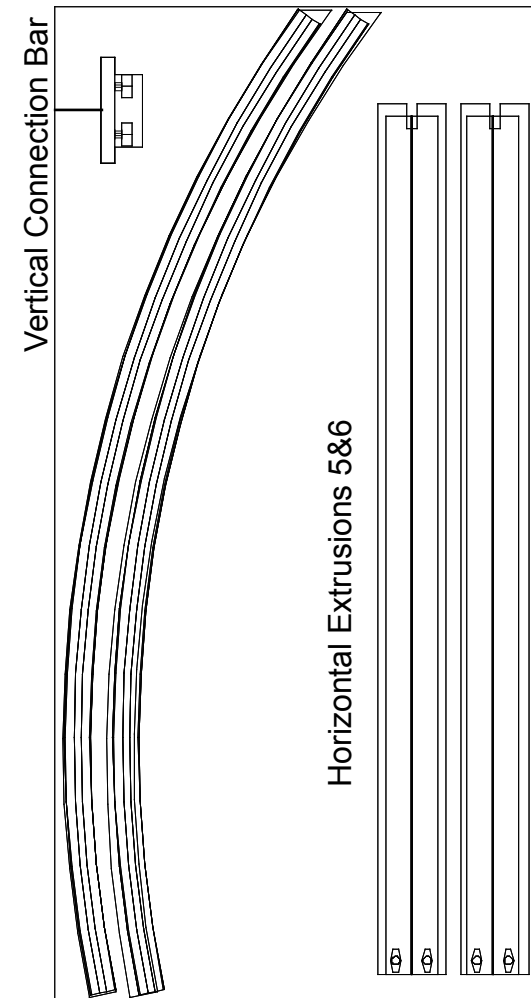
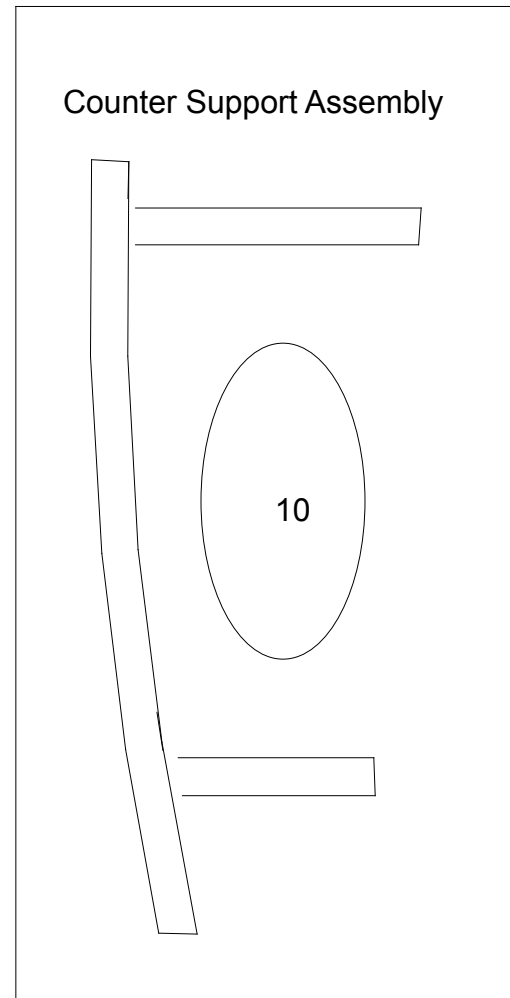
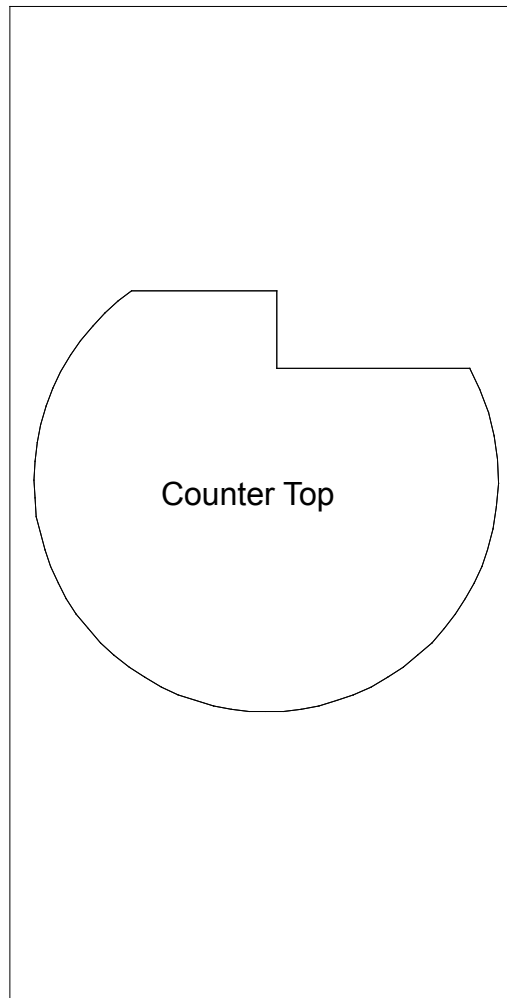

Additional Items:
- Setup Hardware
- Lights

WHEN DISASSEMBLING TIGHTEN ALL KNOBS TO PREVENT LOSS DURING SHIPPING