

WHEN DISASSEMBLING ALUMINUM EXTRUSION, TIGHTEN ALL SETSCREWS AND LOCKS TO PREVENT LOSS DURING SHIPPING

# visionary™ IDESIGNS

## Using Your Setup Instructions

The Visionary Designs Setup Instructions are created specifically for your configuration. They are laid out sequentially, including an exploded view of the entire display, and then a logical series of detailed steps to assemble the main structure and components. We encourage you to study the instructions **before** attempting to assemble your exhibit.

Each page reminds you to tighten the setscrews after disassembling your exhibit to prevent loss of the locks and setscrews (see below in RED). This is **VERY IMPORTANT**.

## Cleaning and Packing Your Display

- 1) Use care when cleaning aluminum extrusion or acrylic inserts. Use only non-abrasive cleaners.
- 2) When cleaning laminate inserts or countertops, use mild cleansers and a soft material such as cotton.
- 3) Keep all display components away from extreme heat and long exposure to sunlight to avoid warping and fading.
- 4) Retain all packing material. It will make re-packing much easier and will reduce the likelihood of shipping damage.



**The Tool**

Most Visionary Designs exhibits can be assembled with the supplied Hex Key Tool. Occasionally, a flat head screwdriver may be required.



**Typical Connection**

Most horizontal extrusion connections have a patented expandable lock. This lock inserts into the groove of an opposing extrusion. Tightening the lock with the Hex Key Tool expands the lock and creates a strong positive connection.



**Typical Connection (cont'd)**



**Detail B**

**Numbered Label**

Each extrusion contains a numbered label which corresponds with setup instructions. The label is located within a groove of the extrusion (when possible). With Visionary Designs the labels contain Black numbers unless otherwise specified.



**Detail C**

**Horizontal Inline Connection** (remove only one setscrew)

Remove only (1) setscrew when disassembling. Replace setscrew in extrusion after assembling it. Before packing, replace setscrew in extrusion to avoid losing it.

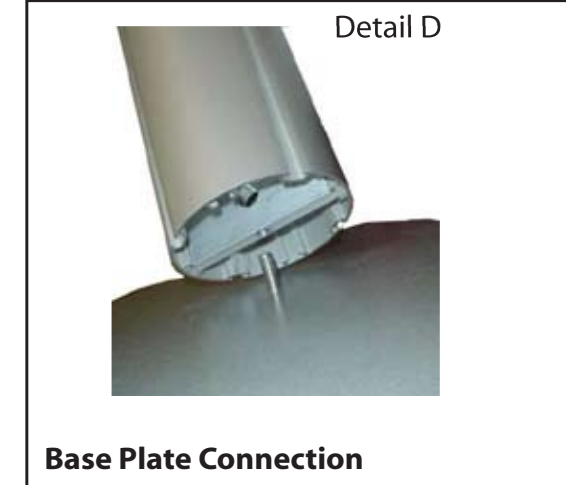

**Detail D**

**Base Plate Connection**

Attach base plate to round or square vertical extrusion using the bolt provided. Be careful not to strip the threads.

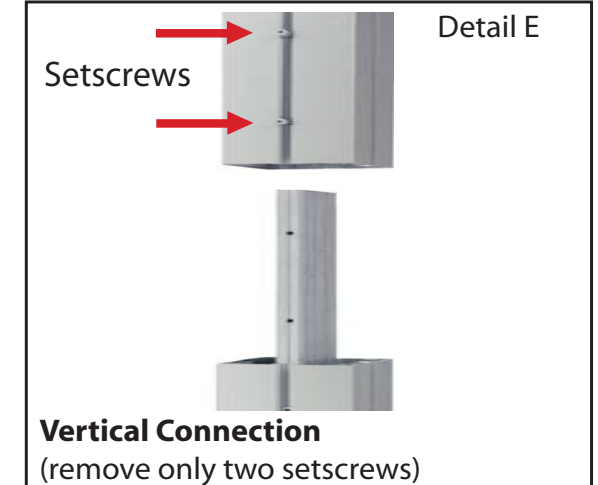

**Detail E**

**Vertical Connection**  
(remove only two setscrews)

When vertical extrusions are packed in portable cases rather than crates or tubs, they must be broken down into smaller sections which then require assembly.

Remove only (2) setscrews when disassembling. Replace setscrews in extrusion after assembling it. Before packing, replace setscrews in extrusion to avoid losing them.

**WHEN DISASSEMBLING ALUMINUM EXTRUSION, TIGHTEN ALL SETSCREWS AND LOCKS TO PREVENT LOSS DURING SHIPPING**

866.652.2100

Item	Qty.	Description
1	3	Oval Base Plate
2	1	83.75"h Vertical Extrusion
3	1	83.75"h Vertical Extrusion
4	1	84"h Vertical Extrusion
5	1	84"h Vertical Extrusion
6	1	83.75"h Vertical Extrusion
7	2	83.5"w Horizontal Extrusion
8	2	23"w Horizontal Extrusion
9	2	28"w Horizontal Extrusion
10	2	52"w Horizontal Extrusion

Steps:

- 1) Attach vertical extrusions [2, 3 and 6] to base plates [1].
- 2) Connect horizontal extrusions [7, 8, 9 and 10] between vertical extrusions [2, 3, 4, 5 and 6], see illustration for horizontal orientation.
- 3) Apply graphics to assembled backwall.

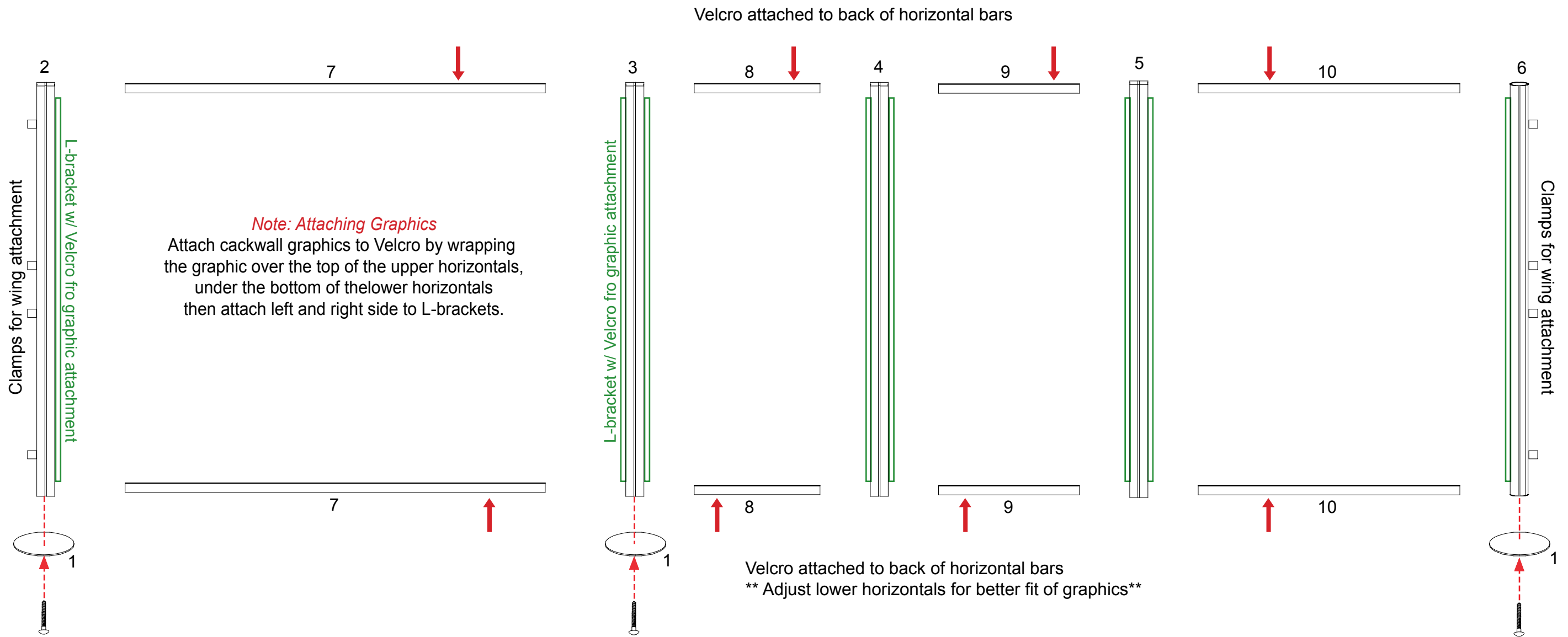

**WHEN DISASSEMBLING ALUMINUM EXTRUSION, TIGHTEN ALL SETSCREWS AND LOCKS TO PREVENT LOSS DURING SHIPPING**

866.652.2100

Item	Qty	Description
11	1	38" h Vertical Extrusion w/ Door Stop
12	1	38" h Vertical Extrusion w/ Door Hinge
13	2	Curved Horizontal Extrusion
14	4	12.5" w Horizontal Extrusion
	4	Internal Shelf Support

Steps

- 1) Attach lower horizontal bars between verticals extrusions where indicated.
- 2) Place infills and attach door as shown.
- 3) Attach upper horizontal bars between verticals extrusions where indicated.
- 4) Velcro shelf supports to inside of assembled base, then set internal shelf atop supports.
- 5) Set counter top on assembled base.

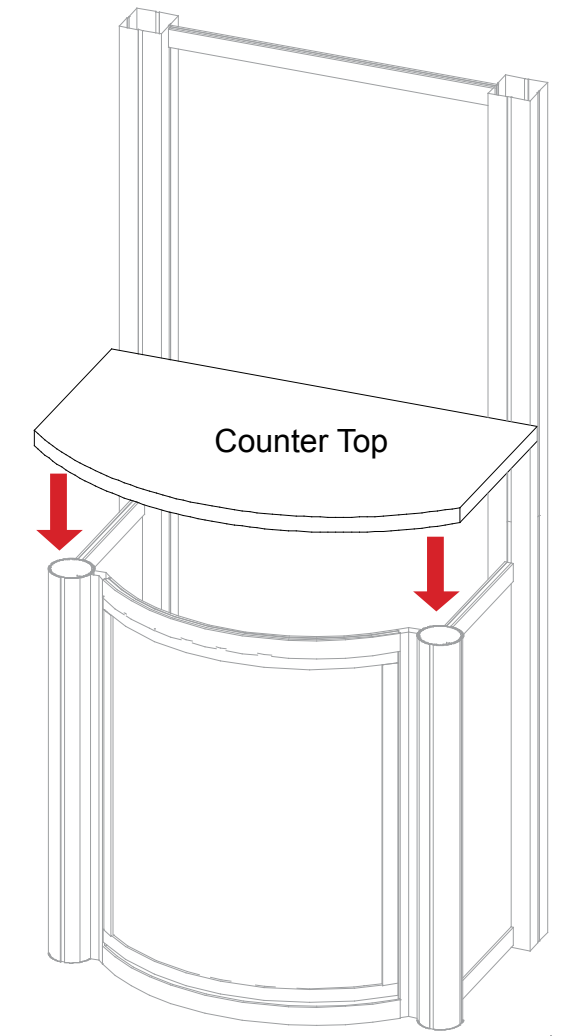
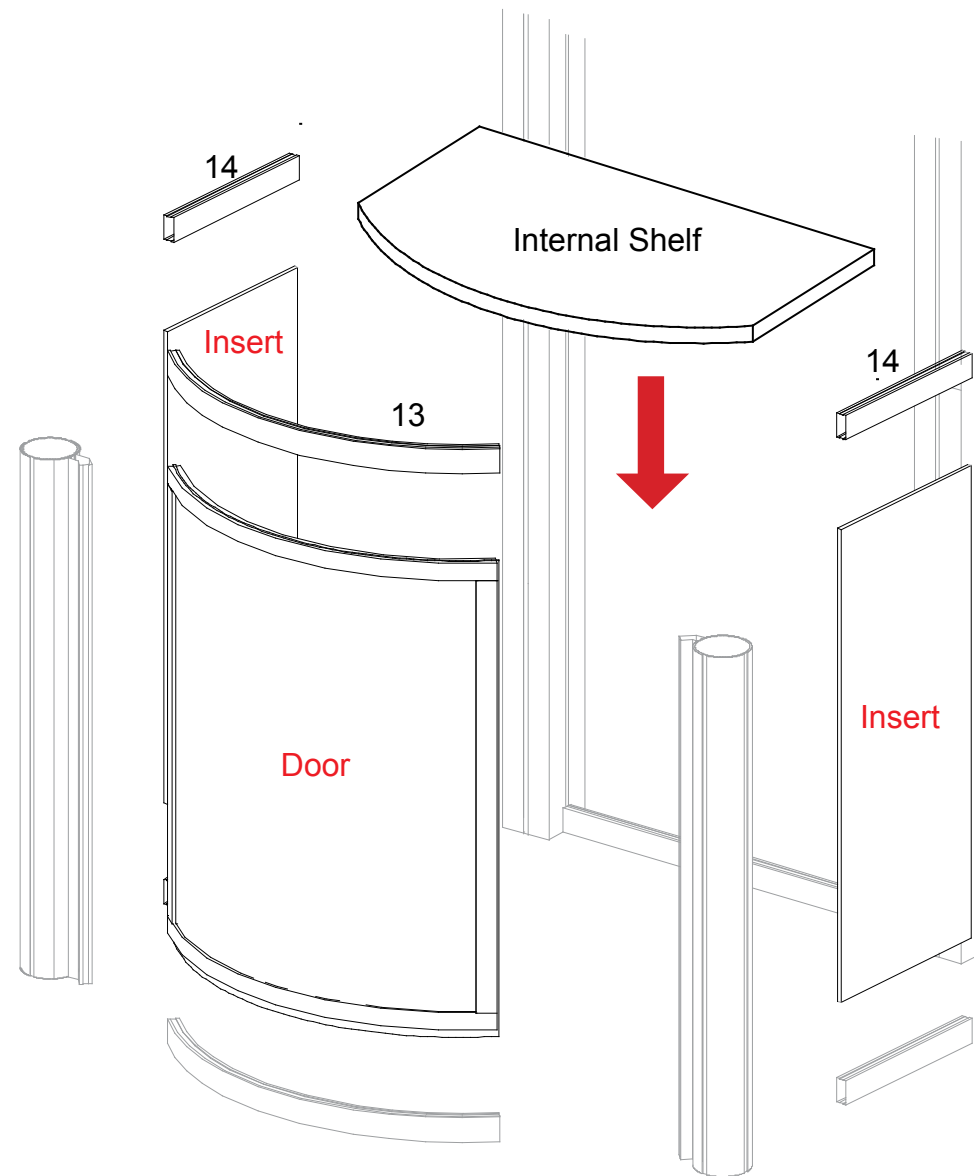
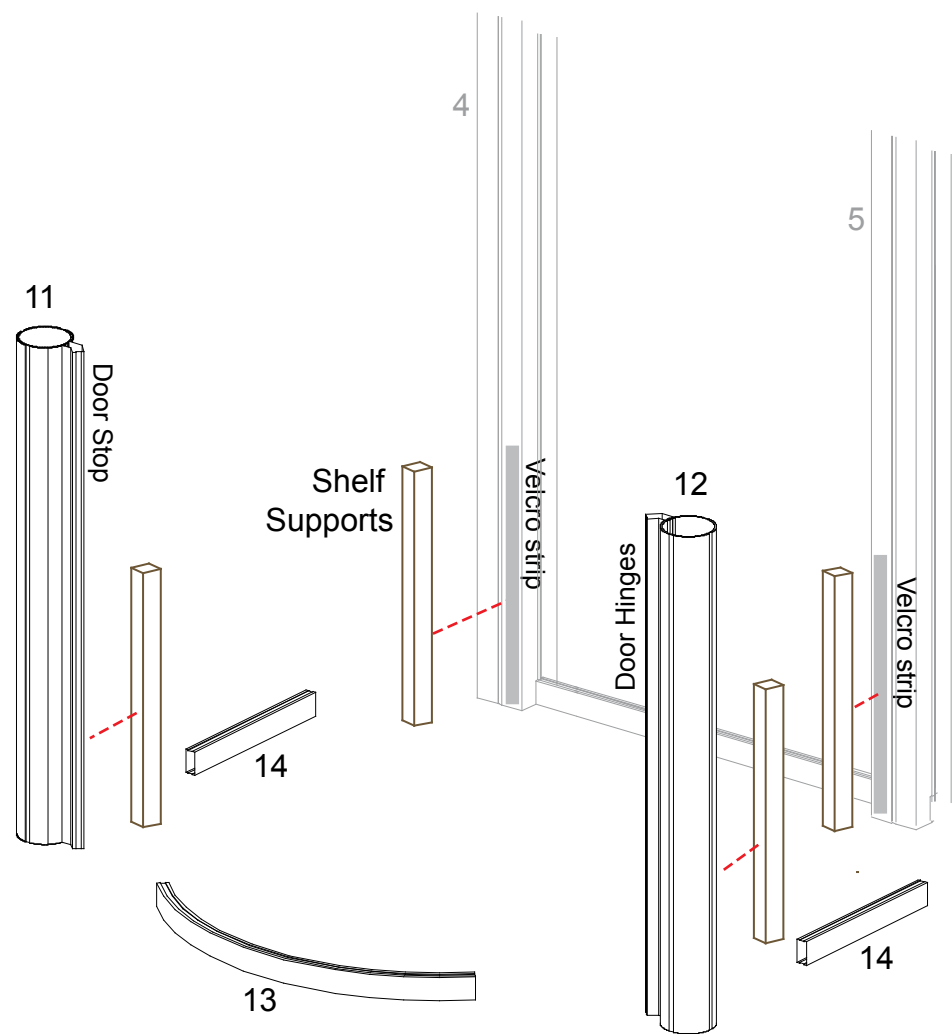
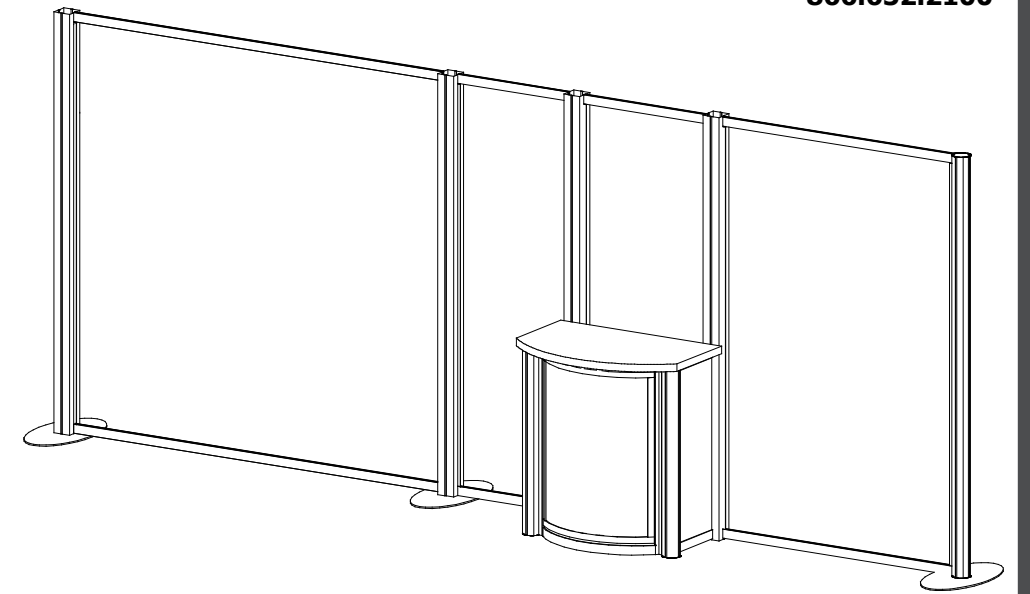

**WHEN DISASSEMBLING ALUMINUM EXTRUSION, TIGHTEN ALL SETSCREWS AND LOCKS TO PREVENT LOSS DURING SHIPPING**

866.652.2100

Item	Qty	Description
15	2	78" Horizontal extrusion
16	2	Left Vertical Extrusion
17	2	Righth Vertical Extrusion
18	2	Upper Curve Horizontal Extrusion

Steps:

- 1) Apply graphics to assembled header frames.
- 2) Attach header frames to ceilings.
- 2) Attach ceilings with assembled headers to top of assembled backwall using bolts.

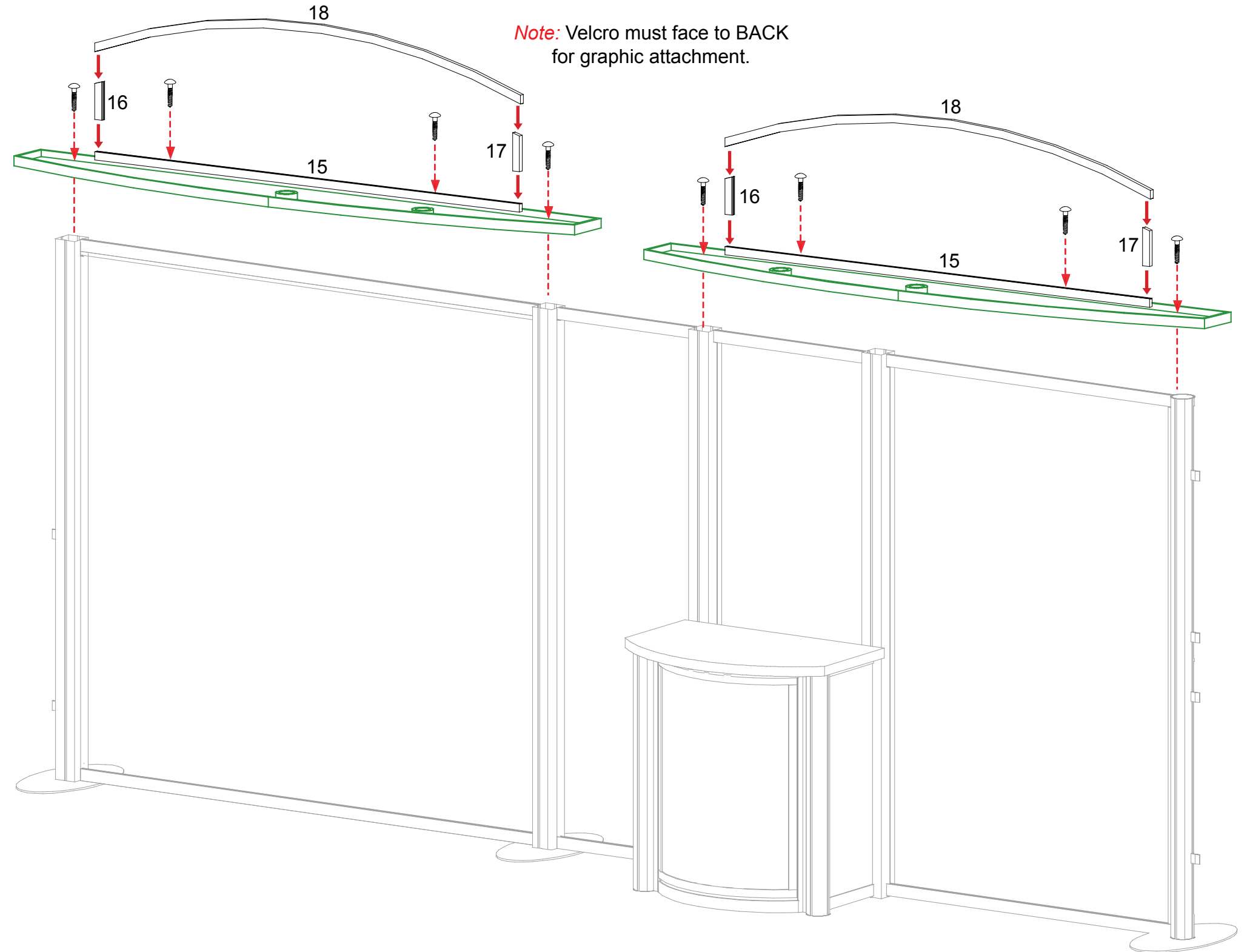

**WHEN DISASSEMBLING ALUMINUM EXTRUSION, TIGHTEN ALL SETSCREWS AND LOCKS TO PREVENT LOSS DURING SHIPPING**

**★ Monitor Mount Attachment**

Attach mounting plate to verticals as shown.

Then attach wall plate to plate using bolts and wing nuts

**Literature Rack Attachment**

Tighten Lock to Secure

Attach connector piece to rack as shown. Then connect assembled literature rack to vertical extrusion.

**A10 Clamp Attachment**  
*(if accidentally removed)*

Slide connector on back of A10 clamp into groove of extrusion.

When desired location is found, tighten set screw to secure.

Tighten black plastic set screw to secure wing in place.

**Sign Attachment**

standoff barrel

Slide stand off barrels into groove of backwall extrusion

Secure Sign to stand off barrels using standoff caps

- Steps:
- 1) Attach 20"D signs using standoff barrels and caps.
  - 2) Attach wings to clamps attached to uprights.
  - 3) Attach literature racks as shown.

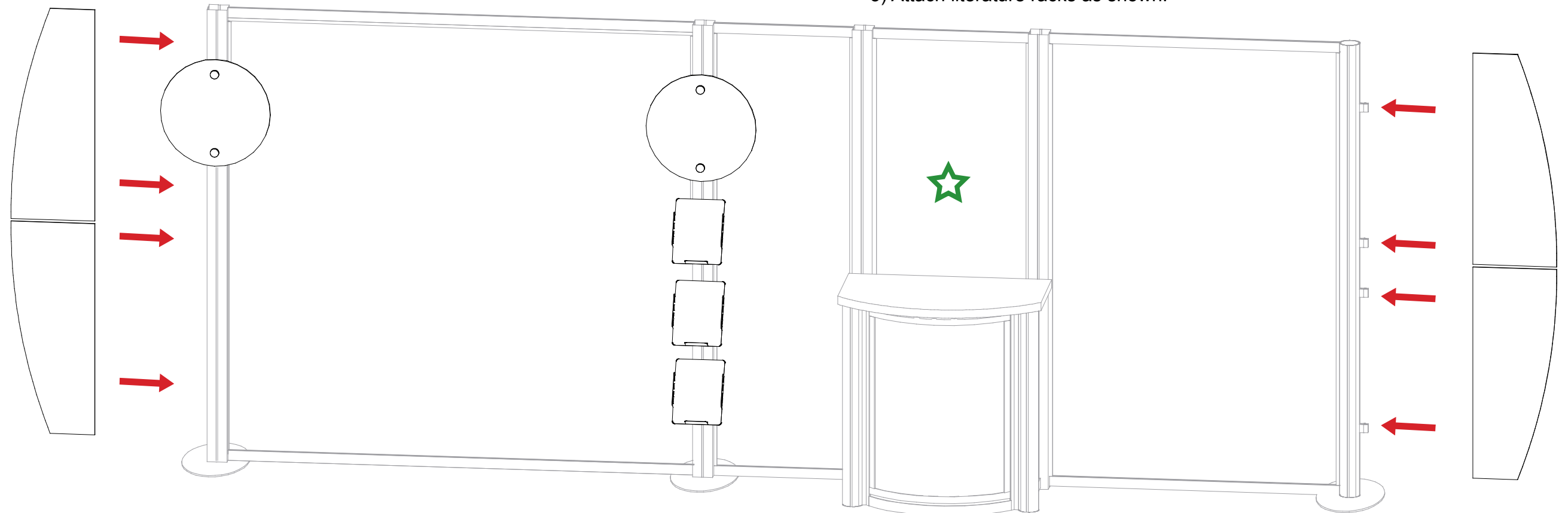

**WHEN DISASSEMBLING ALUMINUM EXTRUSION, TIGHTEN ALL SETSCREWS AND LOCKS TO PREVENT LOSS DURING SHIPPING**

Item	Qty.	Description
19	1	18"D Round Base Plate
20	1	80"h Round Vertical Extrusion
21	1	36"h Round Vertical Extrusion

**Steps**

- 1) Attach vertical extrusions [20] to base plate [21] as shown.
- 2) Attach tapered plex wing to front of vertical extrusion [20] using standoff caps and round sign to vertical extrusion [21].
- 3) Place and attach counter atop vertical extrusion [20].

866.652.2100

Slide connectors onto groove of extrusion, tighten setscrew to secure at desired location.

**Connectors**

*Monitor Mount Attachment*  
 Attach back plate to connectors on vertical extrusion using screws. Then attach top plate and tighten setscrews to secure.

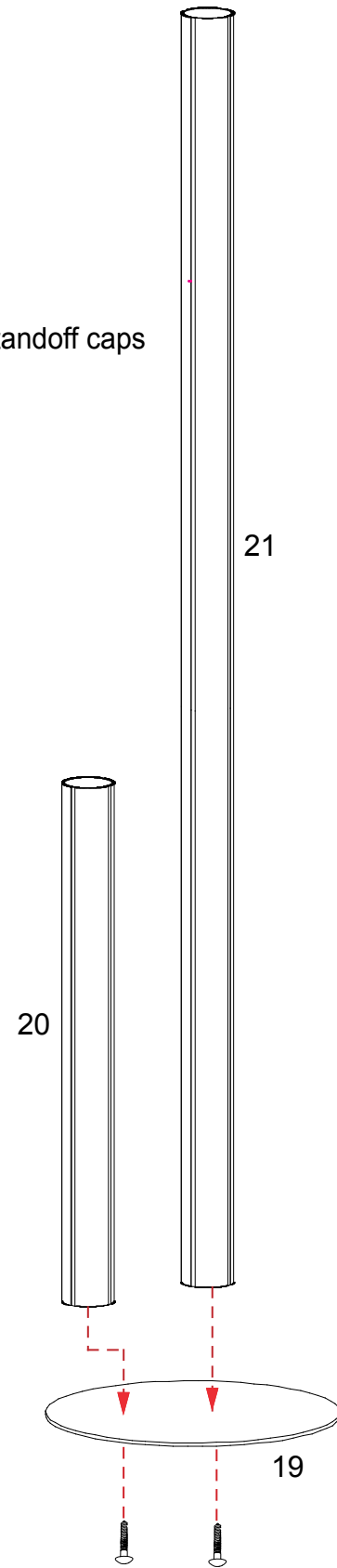

**Sign Attachment**

stand off barrel

Slide stand off barrels into groove of vertical extrusion

Secure Sign to stand off barrels using stand off caps

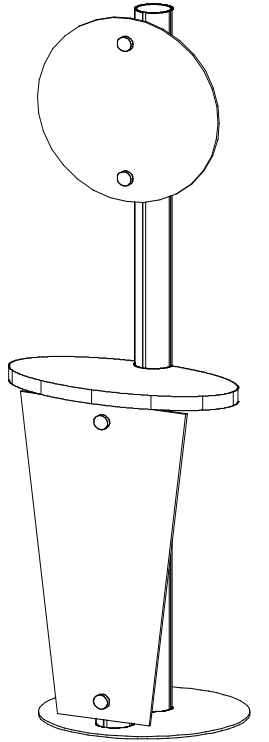
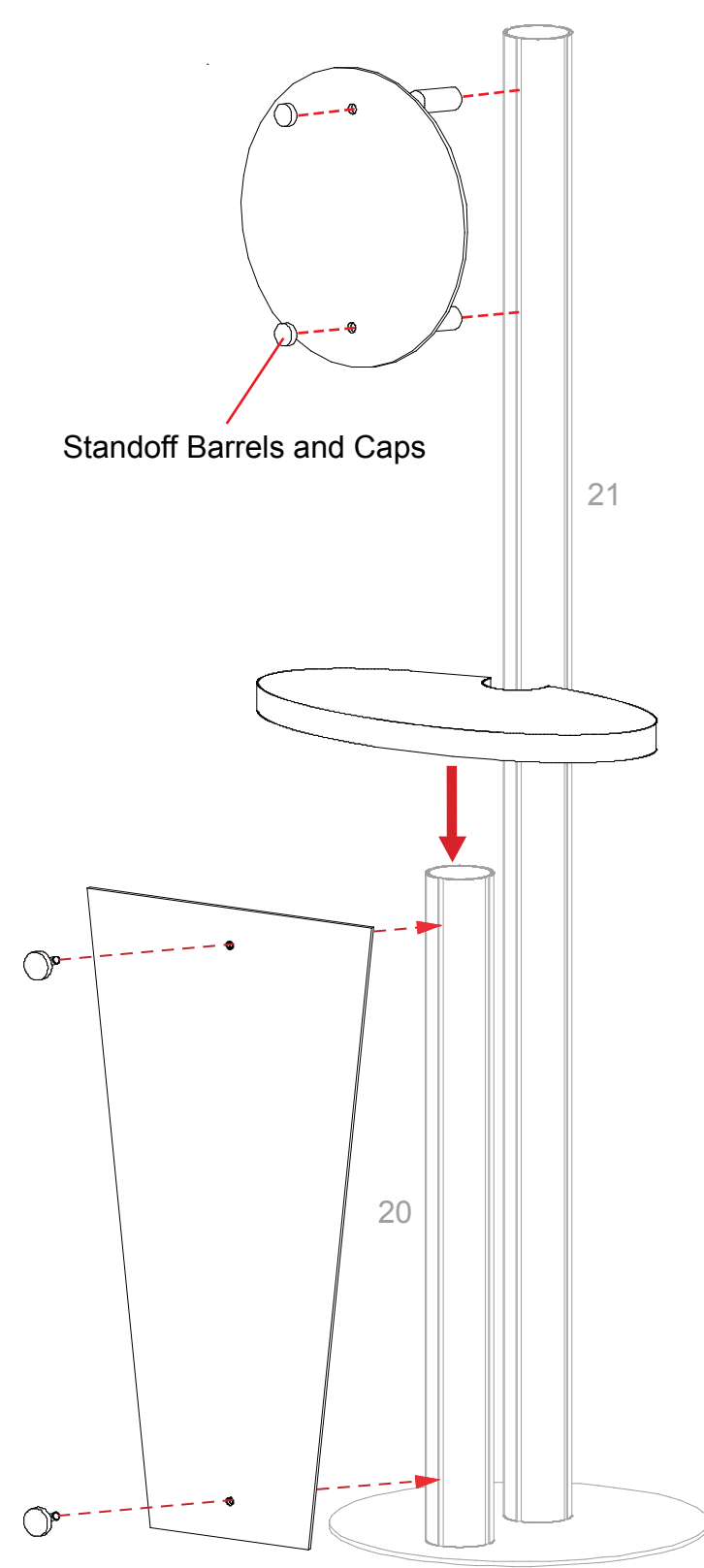

**WHEN DISASSEMBLING ALUMINUM EXTRUSION, TIGHTEN ALL SETSCREWS AND LOCKS TO PREVENT LOSS DURING SHIPPING**

Top View of each Level

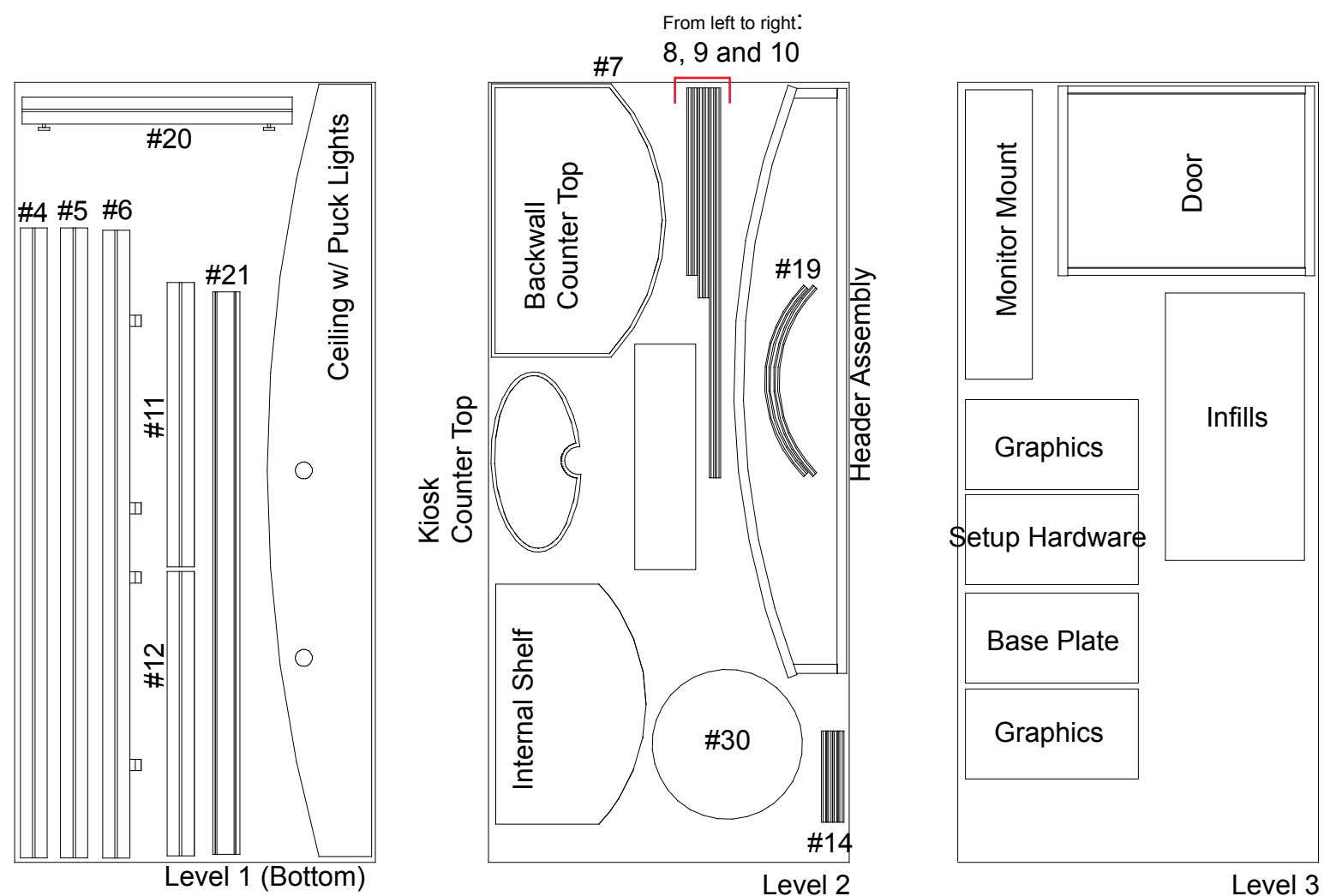

**WHEN DISASSEMBLING ALUMINUM EXTRUSION, TIGHTEN ALL SETSCREWS AND LOCKS TO PREVENT LOSS DURING SHIPPING**

Top View of each Level

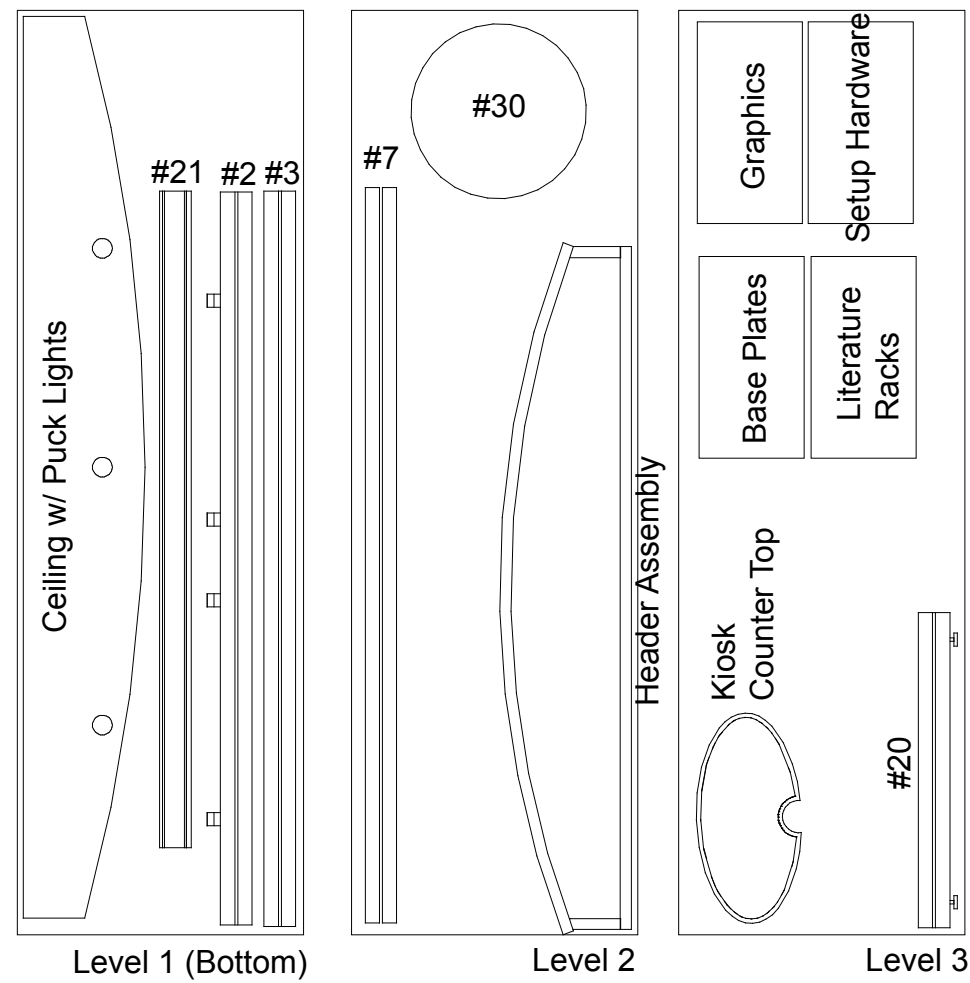

WHEN DISASSEMBLING ALUMINUM EXTRUSION, TIGHTEN ALL SETSCREWS AND LOCKS TO PREVENT LOSS DURING SHIPPING