

Perfect 10 Hybrid Displays

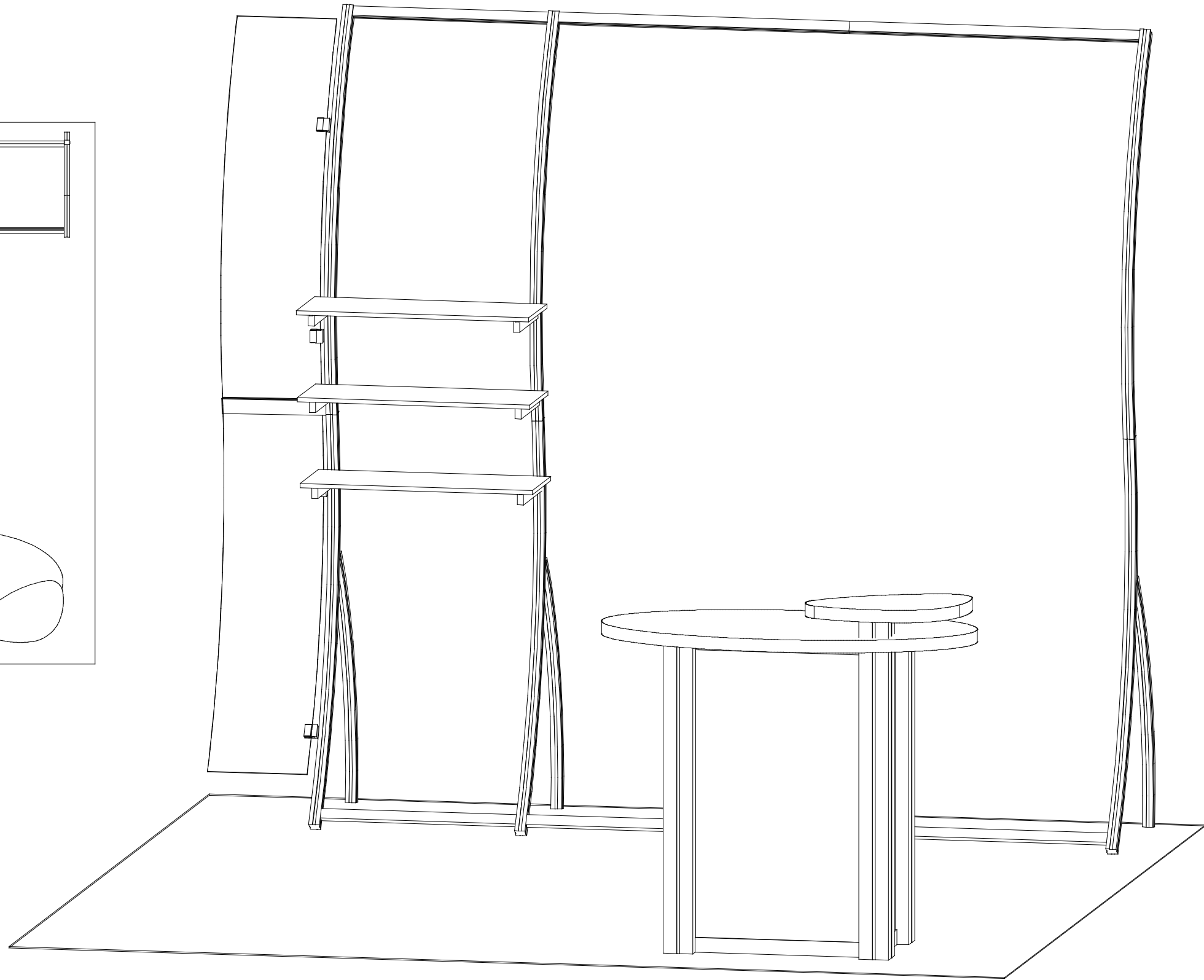
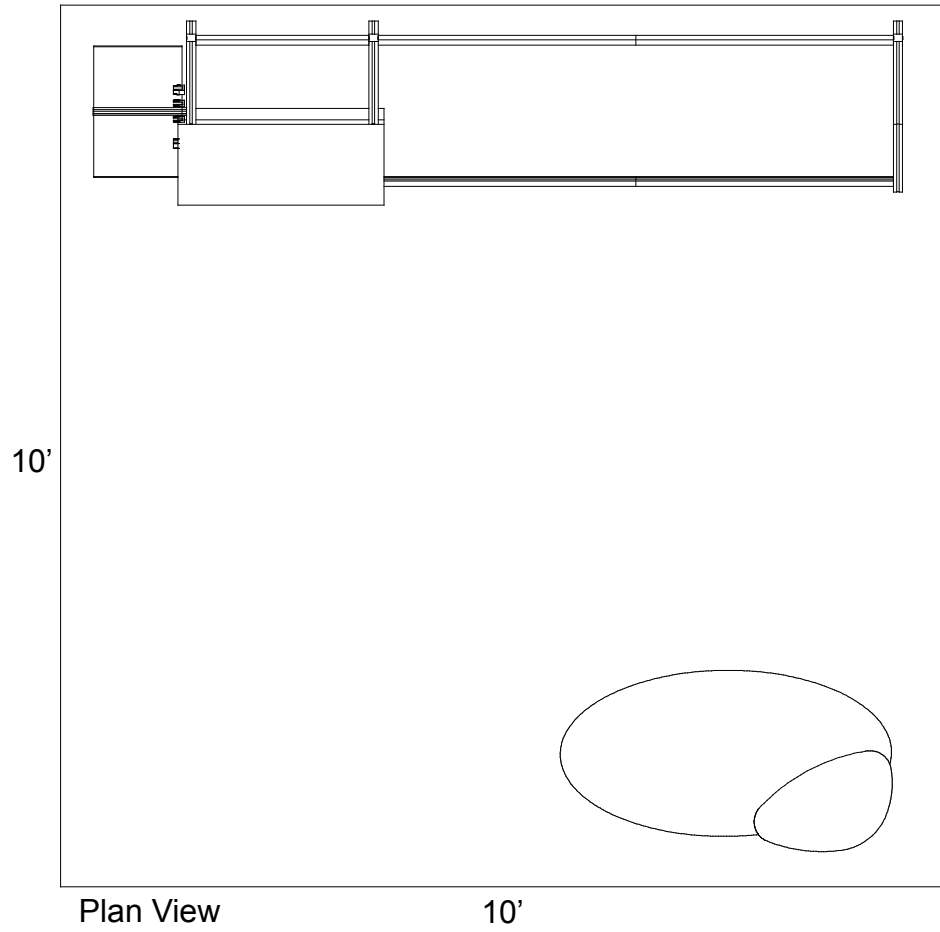

WHEN DISASSEMBLING TIGHTEN ALL KNOBS TO PREVENT LOSS DURING SHIPPING

866.652.2100

| Part Number | Description |
|-------------|--|
| 1 | Left Leg Assembly w/ A10 Clamps Attached |
| 2 | Middle Leg Assembly |
| 3A | Upper Curved Vertical w/ A10 Clamps Attached |
| 3 | Upper Curved Vertical |
| 4 | 23" w Horizontal |

Step 1:

NOTE: Can be assembled either face down on floor then lifted upright or upright as shown in drawings.

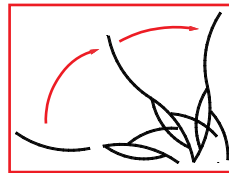

- A) Connect vertical leg assemblies [1 and 2] together by connecting horizontal extrusions [4] between assemblies tightening BLACK knobs on backside of extrusion making sure Velcro faces toward BACK and placing it about one inch up from bottom and tightening.
- B) Connect vertical extrusions [3 and 3A] to leg assemblies [1 and 2] using vertical connection bar as shown.
- C) Connect upper horizontal extrusion [4] between verticals [3 and 3A] placing it about one inch down from top.

NOTE: Make sure the lock is flush with extrusion before tightening. If lock will not fully engage, gently rock lock and extrusion while turning knob until lock fully opens.

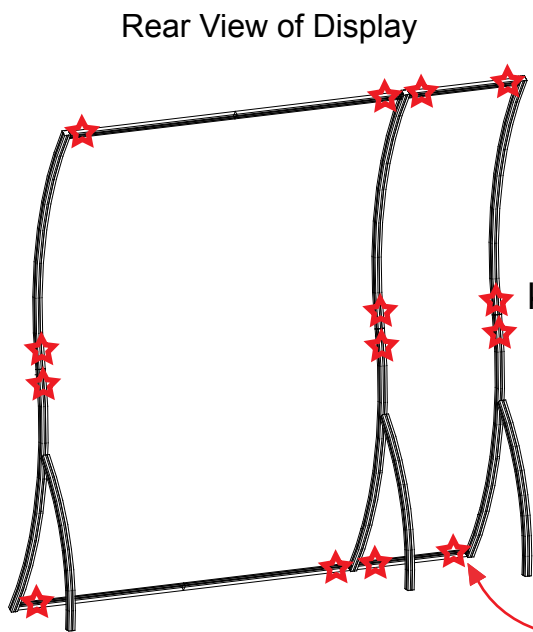

Rear View of Display

STAR indicates location of knobs on BACKSIDE of unit.

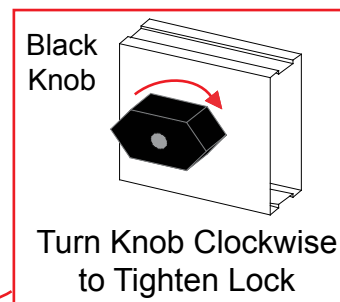

Black Knob

Turn Knob Clockwise to Tighten Lock

Step 1

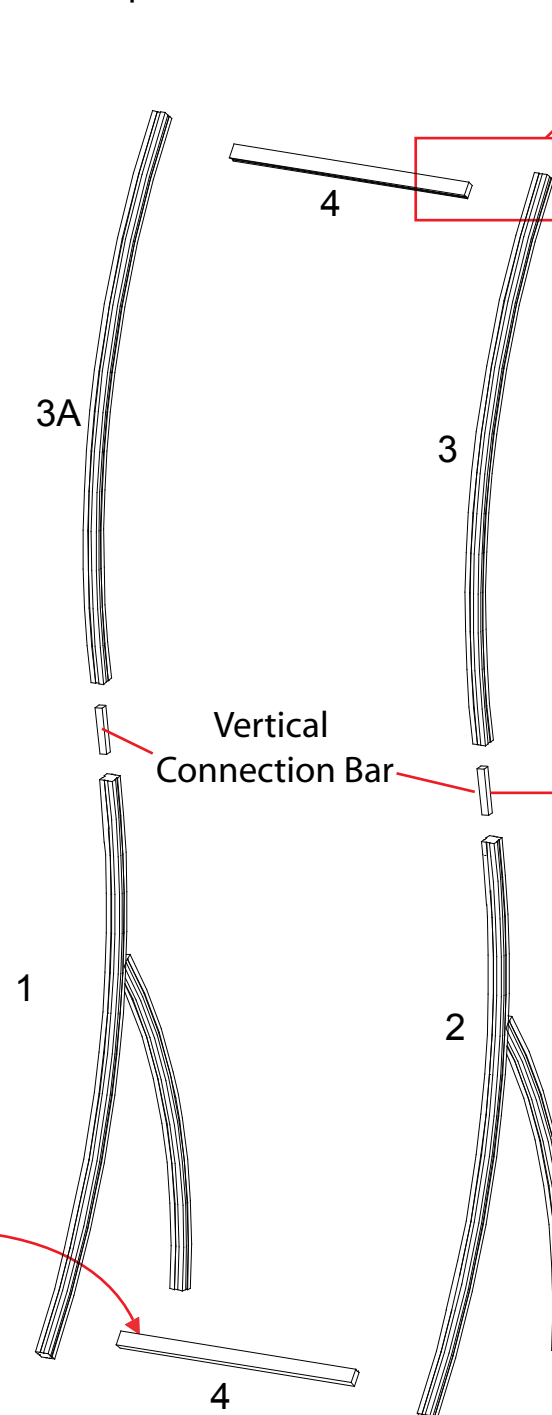

NOTE: When assembling horizontals they should be placed approximately one inch from TOP and BOTTOM.



Slide horizontal into groove

Assure that a good connection is made and tighten to secure.

Slide Connection Bar into lower leg assembly. Slide upper vertical over bar and secure both.

Step stool may be required for assembly.



WHEN DISASSEMBLING TIGHTEN ALL KNOBS TO PREVENT LOSS DURING SHIPPING

866.652.2100

| Part Number | Description |
|-------------|---------------------------------------|
| 5 | Right Leg Assembly |
| 6 | Upper Curved Vertical |
| 7 | 69" w Horizontal w/ Hinge Facing UP |
| 8 | 69" w Horizontal w/ Hinge Facing DOWN |

Step 2

Step 2:

NOTE: Can be assembled either face down on floor then lifted upright or upright as shown in drawings.

- A) Connect vertical extrusion [6] to leg assembly [5] using vertical connection bar as shown.
- B) Connect horizontal extrusions [7 and 8] between vertical assemblies by tightening BLACK knobs on backside of extrusion making sure Velcro faces toward BACK.

NOTE: Make sure the lock is flush with extrusion before tightening. If lock will not fully engage, gently rock lock and extrusion while turning knob until lock fully opens.



NOTE: When assembling horizontals they should be placed approximately one inch from TOP and BOTTOM.

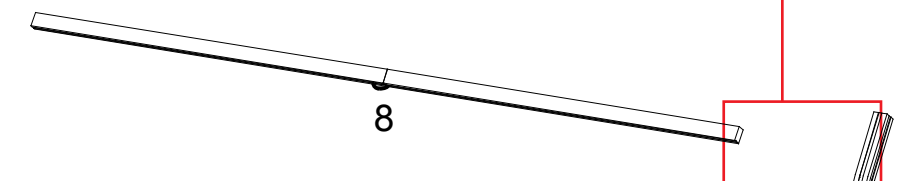

Slide Connection Bar into lower leg assembly. Slide upper vertical over bar and secure both.

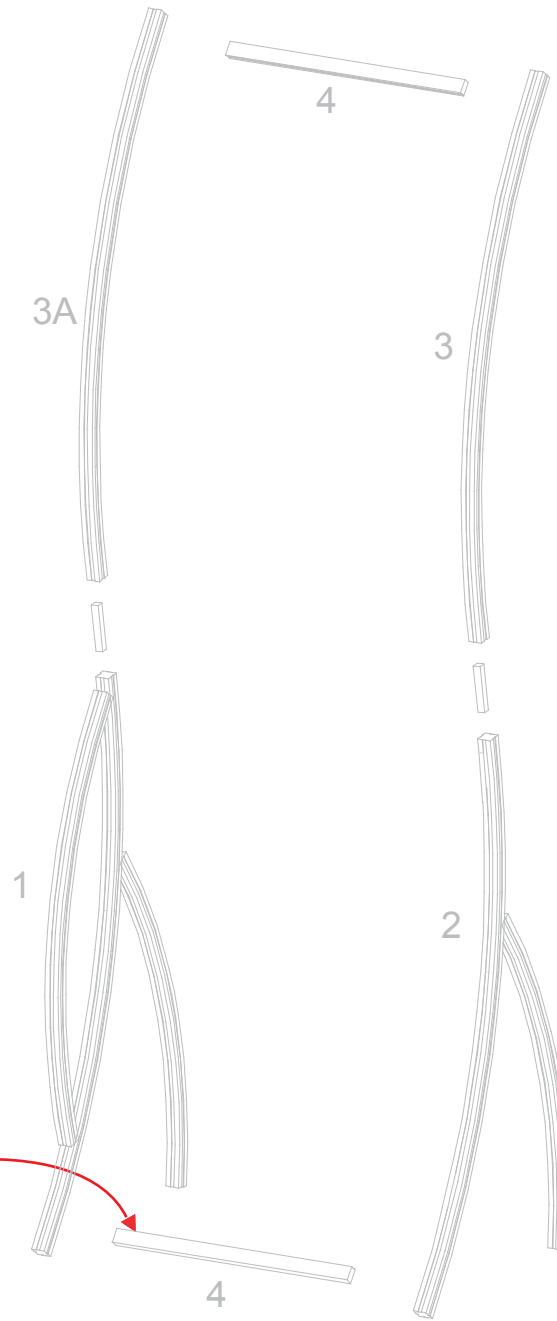

Rear View of Display

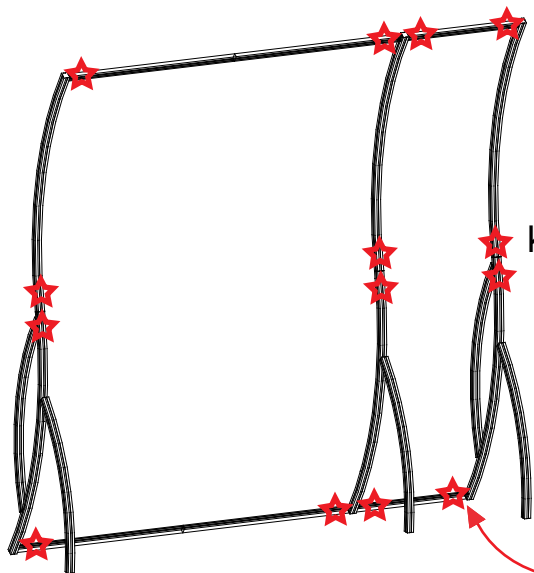

STAR indicates location of knobs on BACKSIDE of unit.

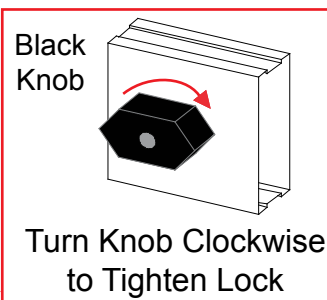

Turn Knob Clockwise to Tighten Lock



Hinge Extrusion
Top Horizontal Hinge **faces down.**
Bottom Horizontal Hinge **faces up.**

WHEN DISASSEMBLING TIGHTEN ALL KNOBS TO PREVENT LOSS DURING SHIPPING

866.652.2100

Decorative Blade Attachment (if accidentally removed)
Slide A10 Clamp into groove of square extrusion.

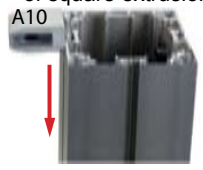

When desired location is found, tighten set screw to secure.

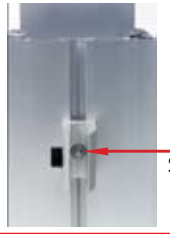

Attach decorative wing and blades to A10's attached to Backwall as shown.





Tighten black plastic set screw to secure Wing in place.



Set-Screw

Black Plastic Set-screw

Hex Key Tool

(if necessary)

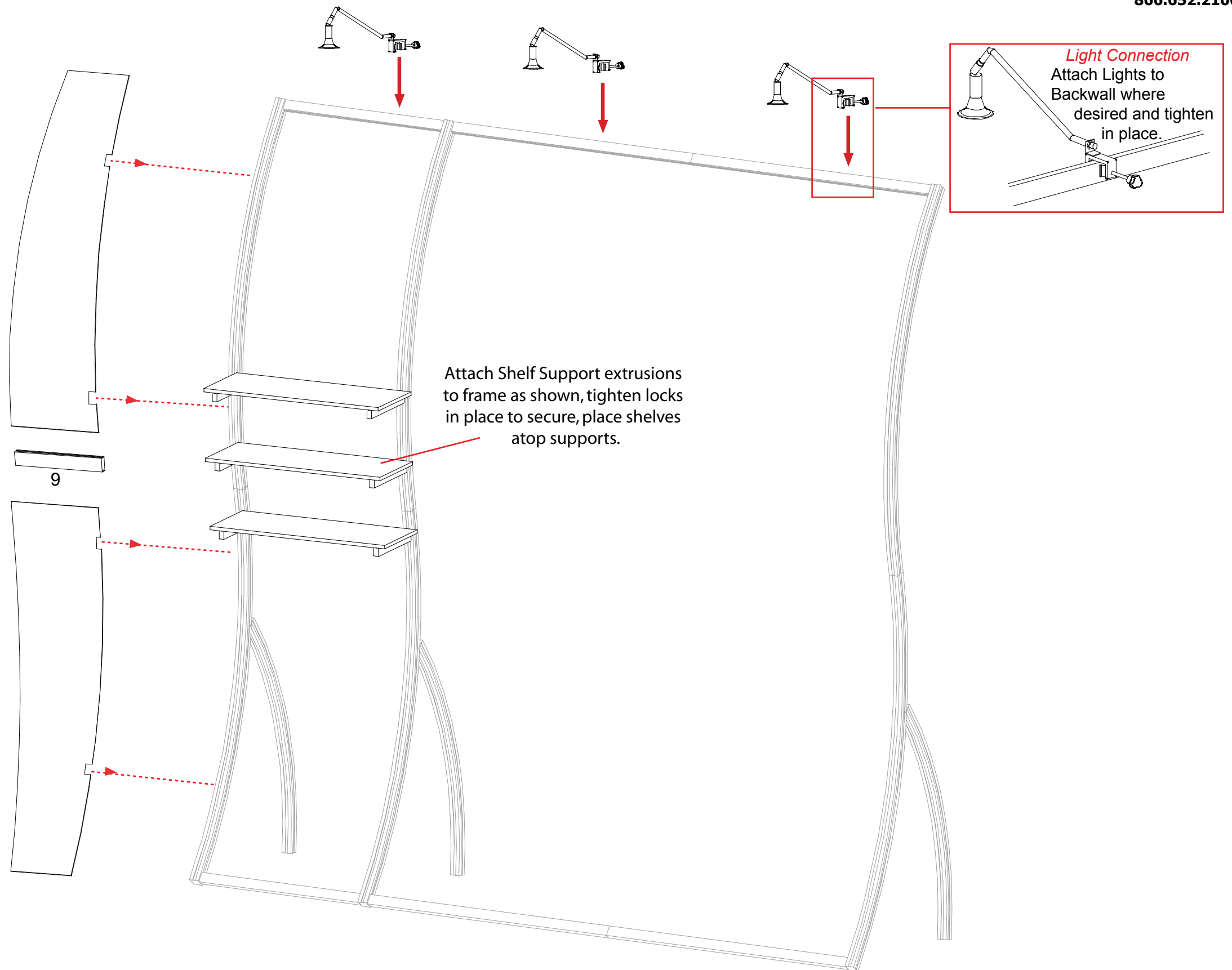
Flathead Screwdriver



WHEN DISASSEMBLING TIGHTEN ALL KNOBS TO PREVENT LOSS DURING SHIPPING

866.652.2100

| Item | Quantity | Description |
|------|----------|------------------------------|
| 9 | 1 | 38"h Vertical Extrusion |
| 10 | 1 | 38"h Vertical Extrusion |
| 11 | 1 | 38"h Vertical Extrusion |
| 12 | 1 | 42"h Vertical Extrusion |
| 11A | 1 | Plate for Counter Connection |
| 13 | 2 | 20"w Horizontal Extrusion |
| 14 | 2 | 8.5"w Horizontal Extrusion |
| 15 | 2 | 20"w Horizontal Extrusion |
| 16 | 2 | 8.5"w Horizontal Extrusion |

Steps:

- 1) Connect horizontal extrusions [13 and 14] between vertical extrusions [9, 10, 11 and 12] resting atop stoppers at approximately 4" up from floor to bottom of metal.
- 2) Set floor in place atop lip of horizontal extrusions.
- 3) Place doors and inserts in place as shown.
- 4) Connect horizontal extrusions [13 and 14] between vertical extrusions [9, 10, 11 and 12] and atop inserts and door.
- 5) Place counter atop assembled pedestal, attach [11a] to extrusion [11] then connect smaller counter to [11a].

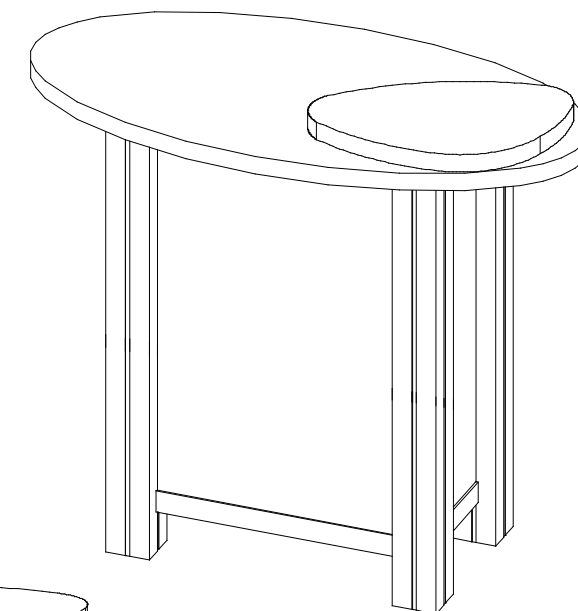

NOTE: TOP SIDE Label needs to be at top of round extrusion.

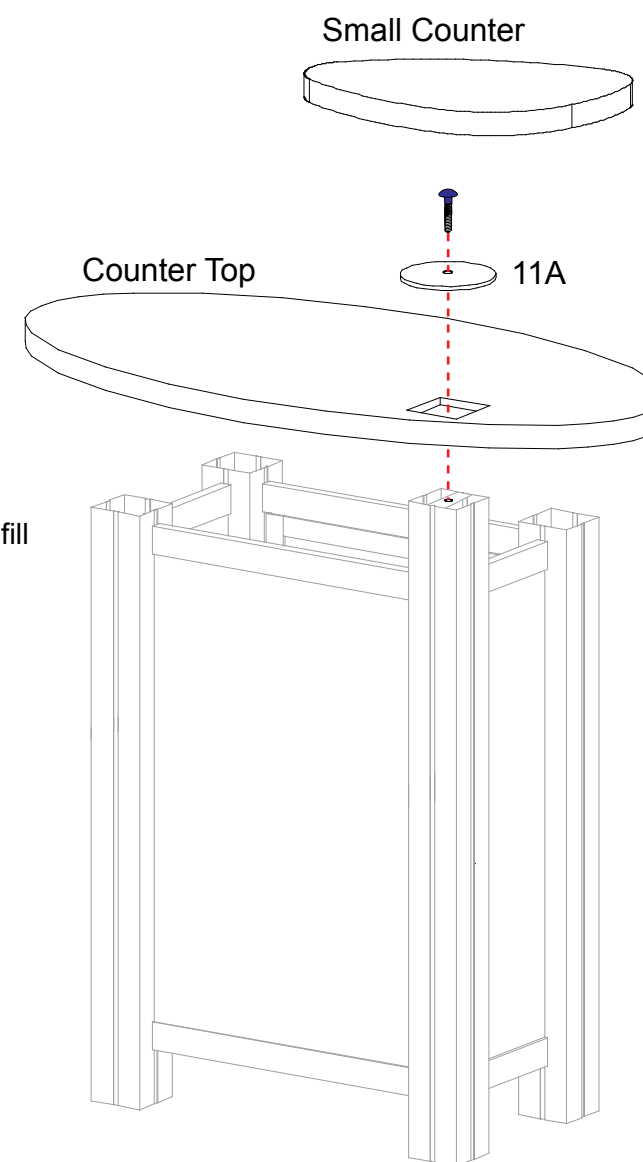
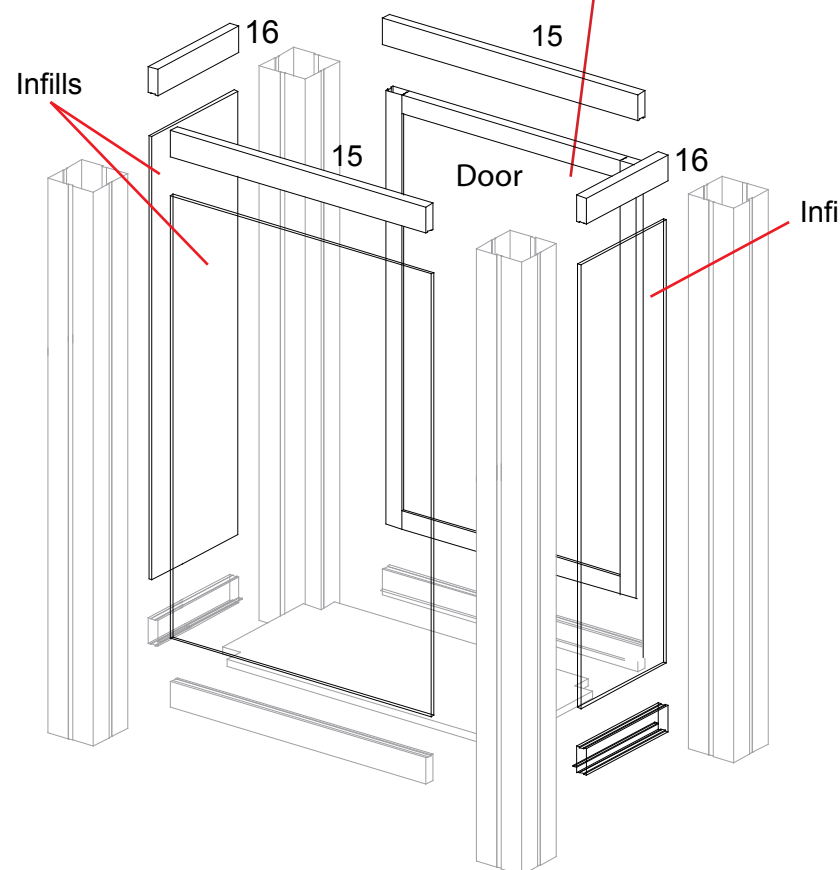
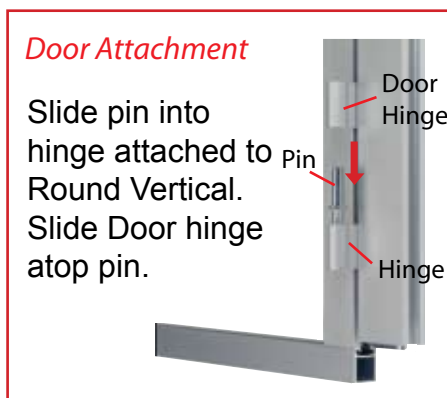
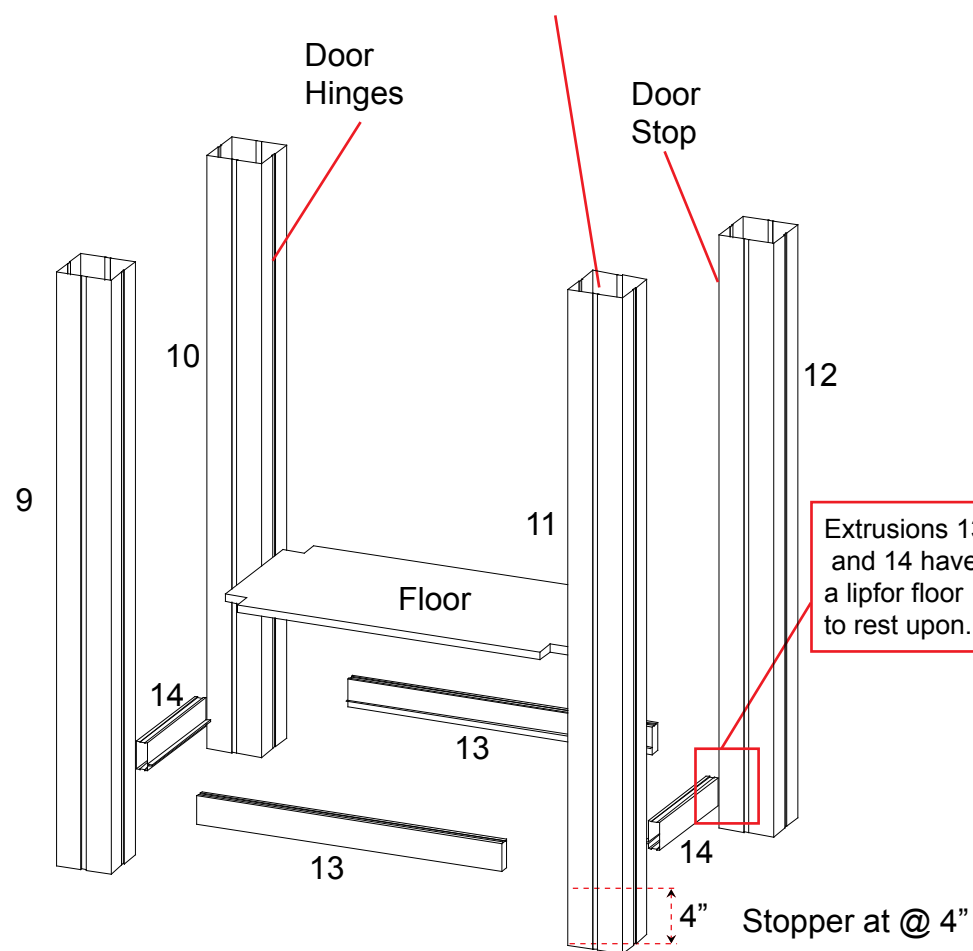

WHEN DISASSEMBLING TIGHTEN ALL KNOBS TO PREVENT LOSS DURING SHIPPING

Case #1 - Backwall Components

Top View of each Level

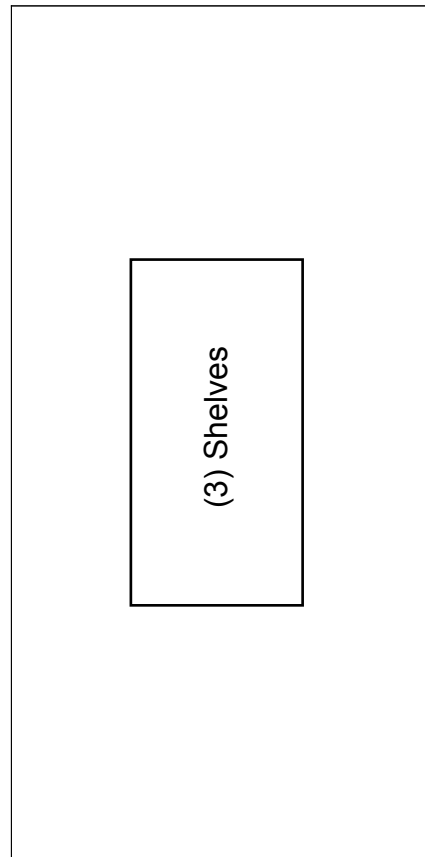

Level 6

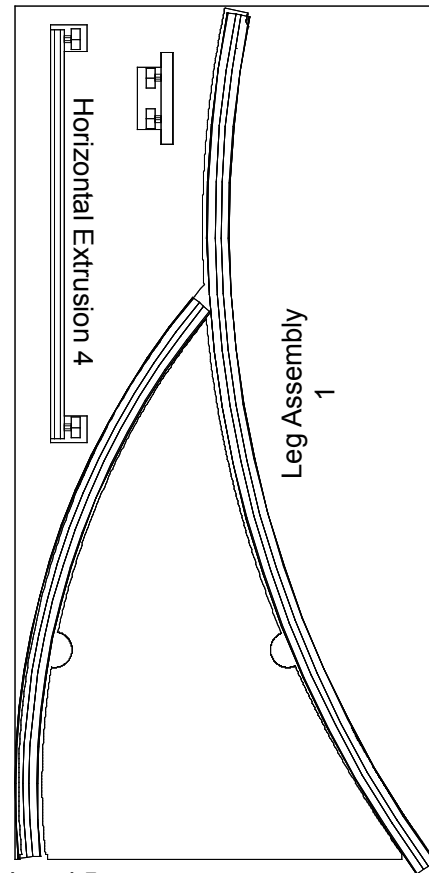

Level 5

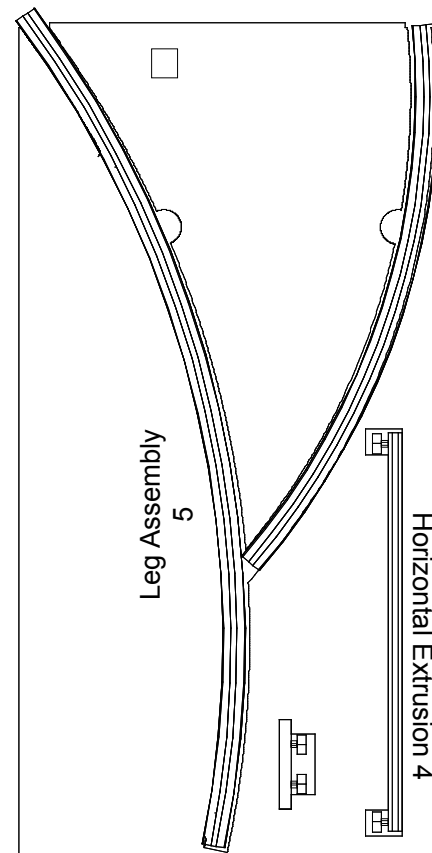

Level 4

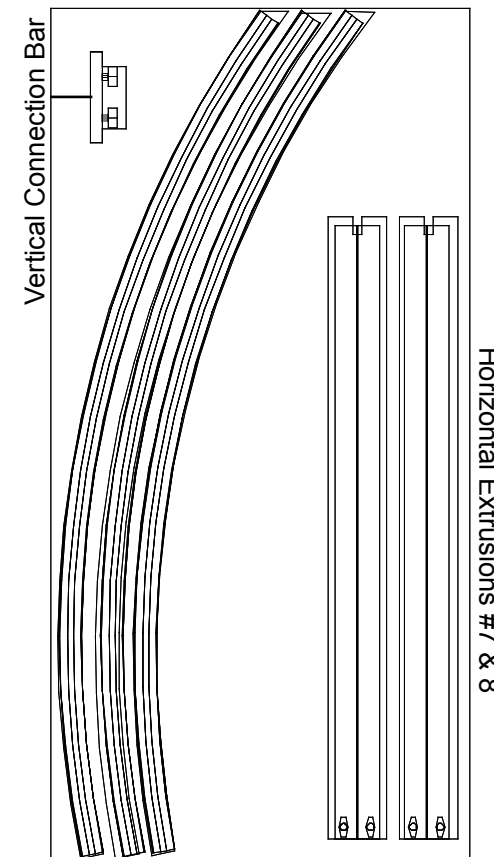

Level 3

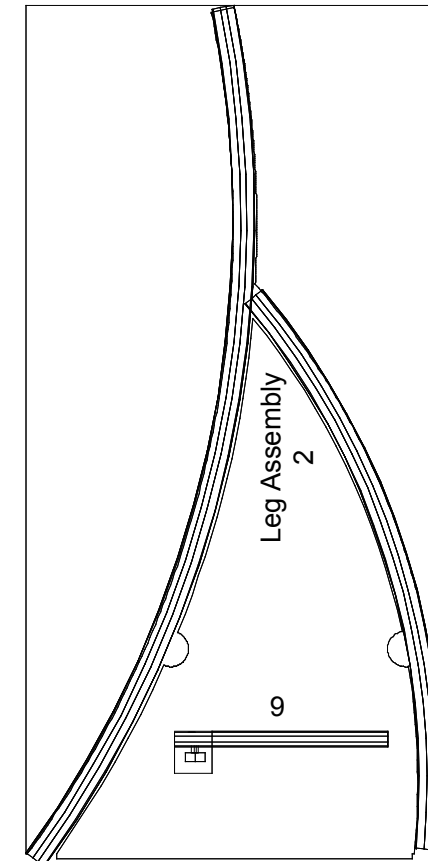

Level 2

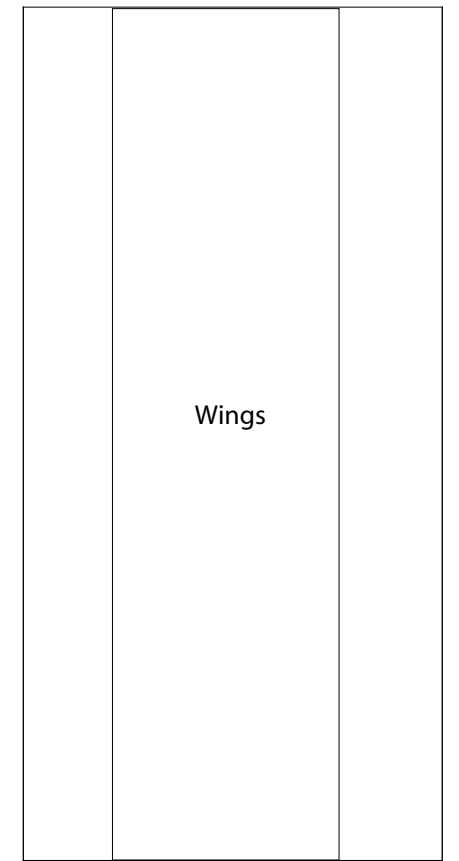

Level 1

Additional Items:
- Setup Hardware
- Lights

WHEN DISASSEMBLING TIGHTEN ALL KNOBS TO PREVENT LOSS DURING SHIPPING

Top View of Each Level

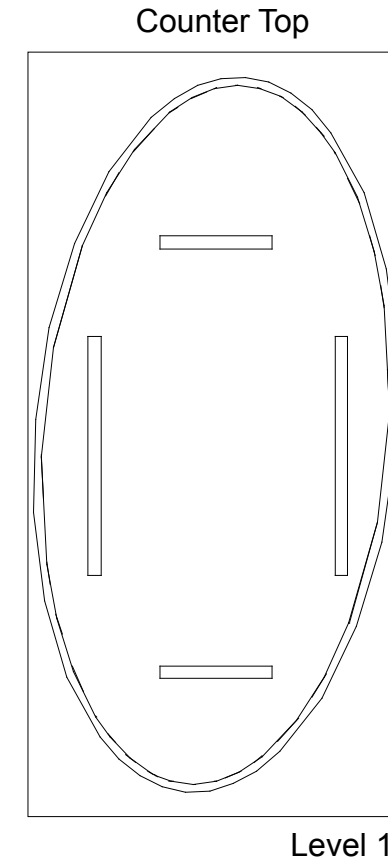
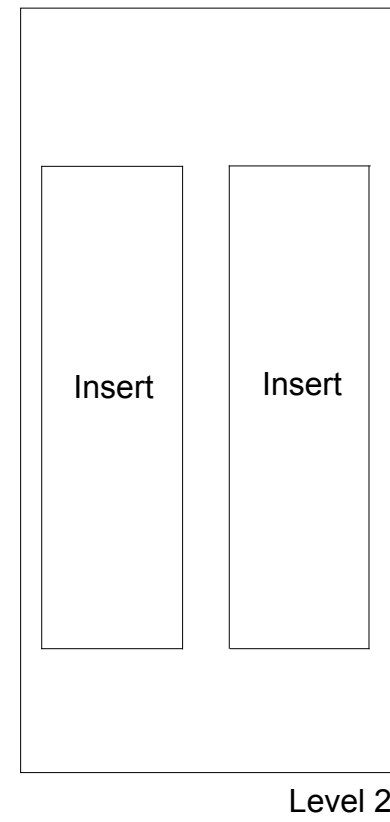
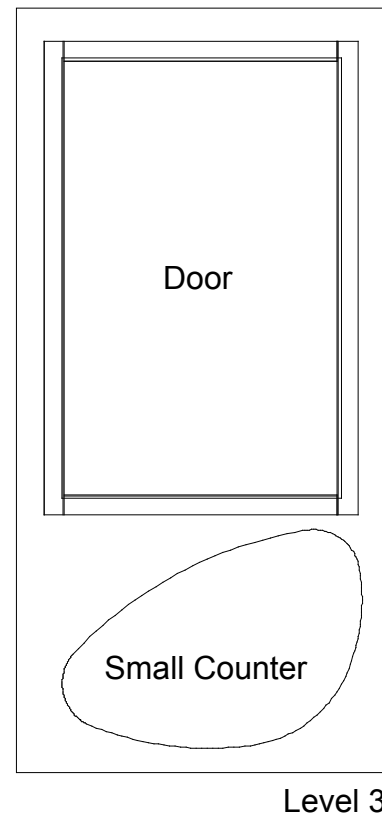
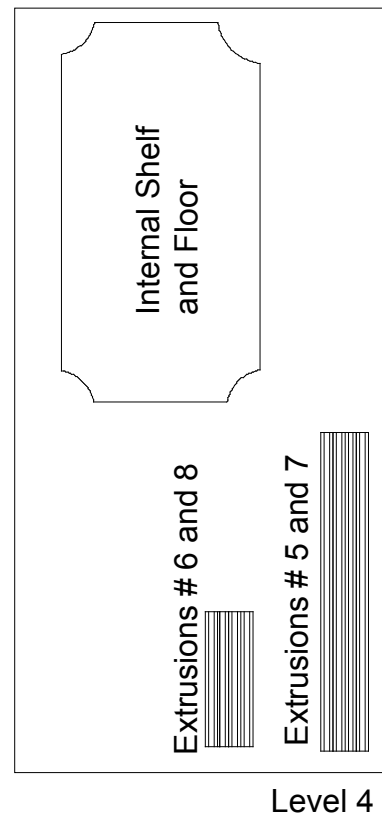
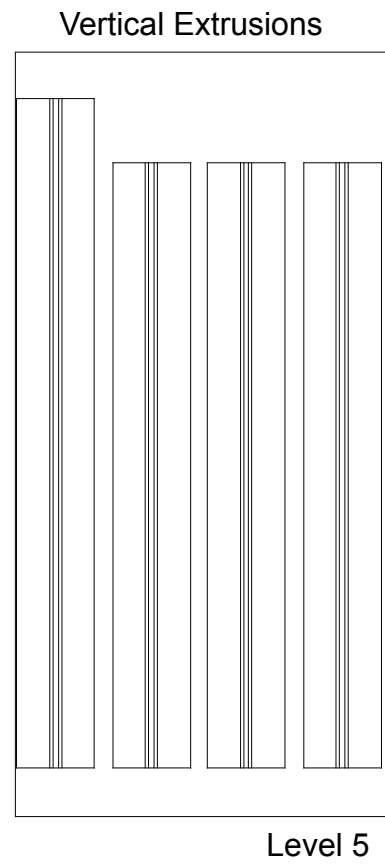

Additional Items:
- Setup Hardware

WHEN DISASSEMBLING TIGHTEN ALL KNOBS TO PREVENT LOSS DURING SHIPPING