

10'

Plan View

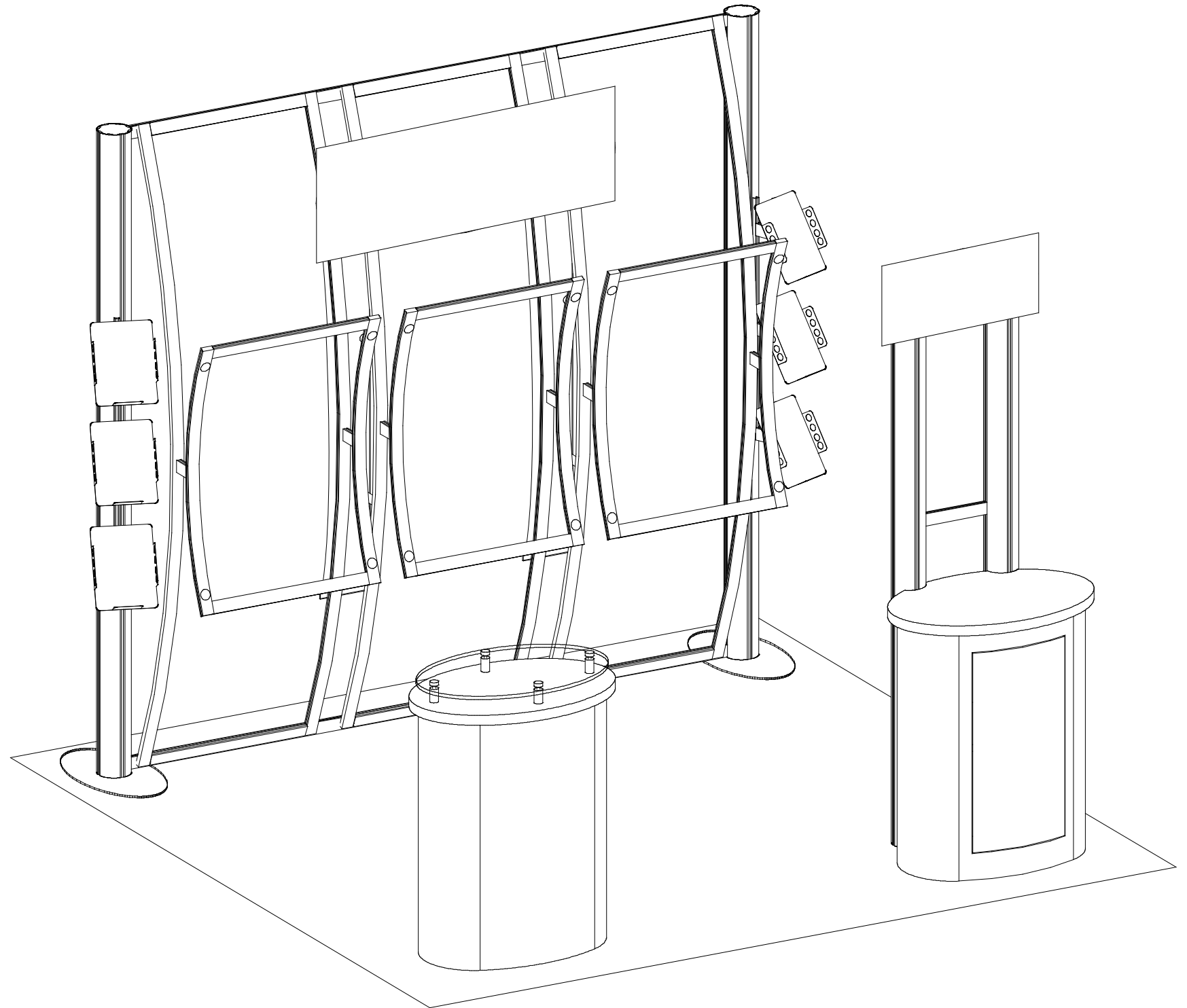

10'



WHEN DISASSEMBLING ALUMINUM EXTRUSION, TIGHTEN ALL SETSCREWS AND LOCKS TO PREVENT LOSS DURING SHIPPING

visionary™ DESIGNS

Using Your Setup Instructions

The Visionary Designs Setup Instructions are created specifically for your configuration. They are laid out sequentially, including an exploded view of the entire display, and then a logical series of detailed steps to assemble the main structure and components. We encourage you to study the instructions **before** attempting to assemble your exhibit.

Each page reminds you to tighten the setscrews after disassembling your exhibit to prevent loss of the locks and setscrews (see below in RED). This is **VERY IMPORTANT**.

Cleaning and Packing Your Display

- 1) Use care when cleaning aluminum extrusion or acrylic inserts. Use only non-abrasive cleaners.
- 2) When cleaning laminate inserts or countertops, use mild cleansers and a soft material such as cotton.
- 3) Keep all display components away from extreme heat and long exposure to sunlight to avoid warping and fading.
- 4) Retain all packing material. It will make re-packing much easier and will reduce the likelihood of shipping damage.



The Tool

Most Visionary Designs exhibits can be assembled with the supplied Hex Key Tool. Occasionally, a flat head screwdriver may be required.



Typical Connection



Typical Connection (cont'd)

Most horizontal extrusion connections have a patented expandable lock. This lock inserts into the groove of an opposing extrusion. Tightening the lock with the Hex Key Tool expands the lock and creates a strong positive connection.

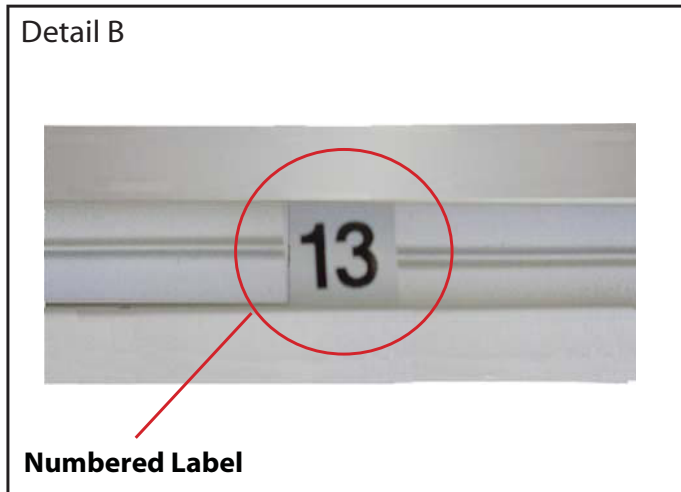

Numbered Label

Each extrusion contains a numbered label which corresponds with setup instructions. The label is located within a groove of the extrusion (when possible). With Visionary Designs the labels contain Black numbers unless otherwise specified.



Horizontal Inline Connection (remove only one setscrew)

Remove only (1) setscrew when disassembling. Replace setscrew in extrusion after assembling it. Before packing, replace setscrew in extrusion to avoid losing it.

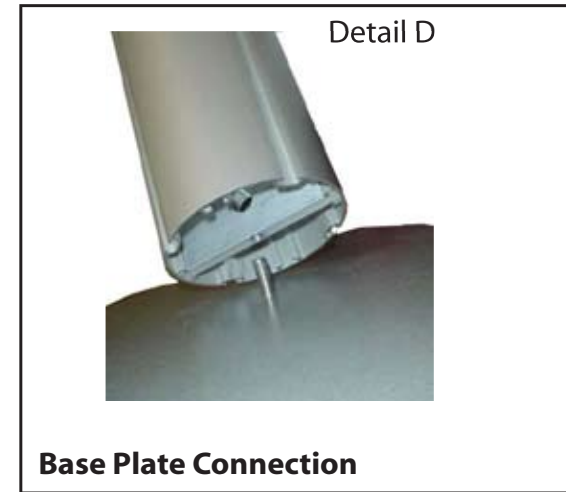

Base Plate Connection

Attach base plate to round or square vertical extrusion using the bolt provided. Be careful not to strip the threads.

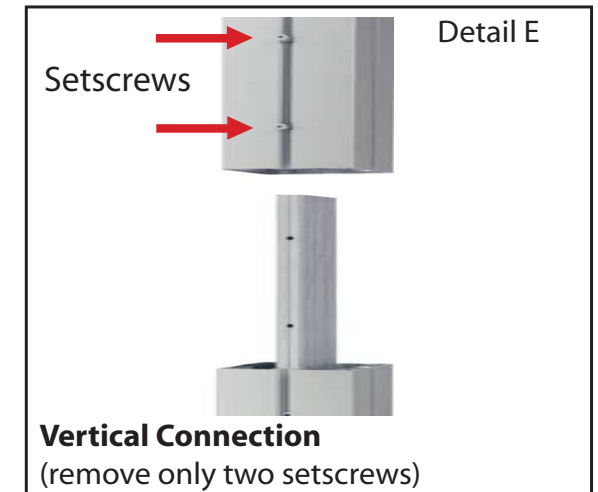

Vertical Connection
(remove only two setscrews)

When vertical extrusions are packed in portable cases rather than crates or tubs, they must be broken down into smaller sections which then require assembly.

Remove only (2) setscrews when disassembling. Replace setscrews in extrusion after assembling it. Before packing, replace setscrews in extrusion to avoid losing them.



WHEN DISASSEMBLING ALUMINUM EXTRUSION, TIGHTEN ALL SETSCREWS AND LOCKS TO PREVENT LOSS DURING SHIPPING

866.652.2100

Part Number	Qty for Step	Description
1	2	Base Plates
2a/2b	1/1	48" Vertical extrusion
3a/3b	1/1	48" Vertical extrusion
4a/4b	1/1	48" Lower Horizontal w/ Velcro attached to Top of member
5a/5b	1/1	48" Upper Horizontal w/ Velcro attached to Bottom of member
6a/6b	1/1	46.165" Vertical extrusion

Steps

- 1) Attach lower vertical extrusions [2a and 3a] to base plates.
- 2) Connect upper vertical extrusions to lower extrusions [2a to 2b and 2a to 2b].
- 3) Connect horizontal and vertical extrusions together [4a to 4b, 5a to 5b and 6a to 6b].
- See illustration for Velcro locations -
- 4) Connect horizontal assemblies between vertical assemblies as shown.

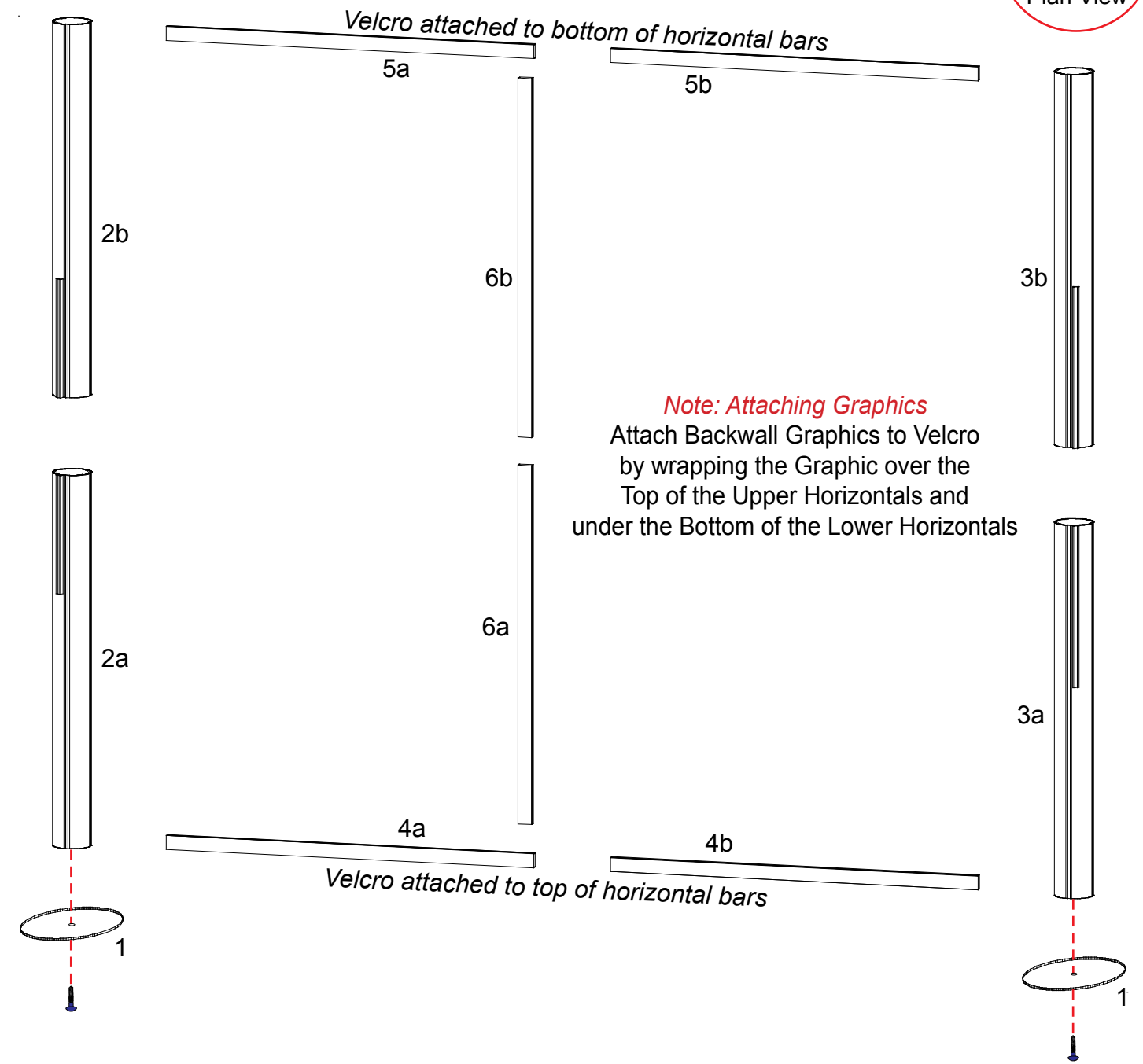
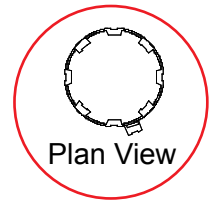
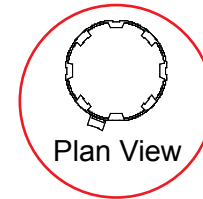
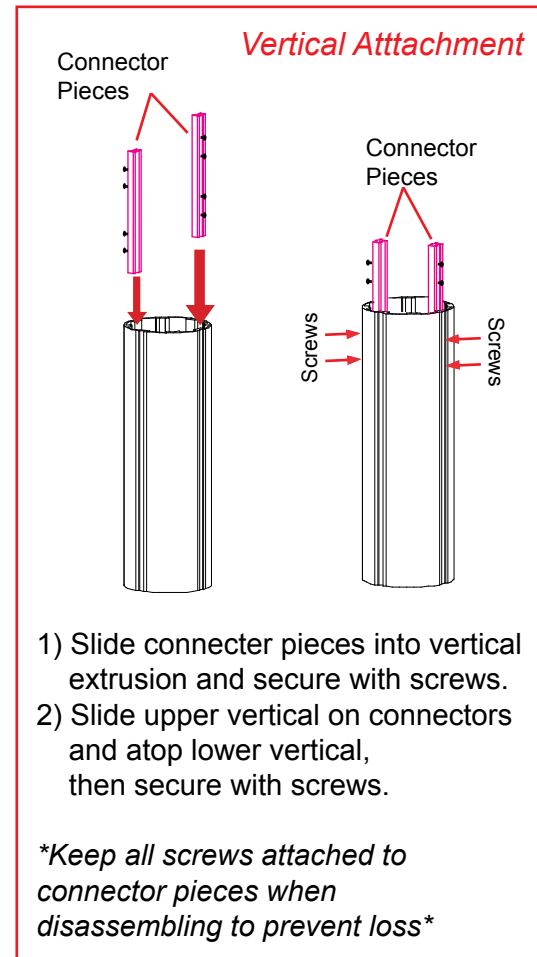

Note: Attaching Graphics
Attach Backwall Graphics to Velcro by wrapping the Graphic over the Top of the Upper Horizontals and under the Bottom of the Lower Horizontals



WHEN DISASSEMBLING ALUMINUM EXTRUSION, TIGHTEN ALL SETSCREWS AND LOCKS TO PREVENT LOSS DURING SHIPPING

866.652.2100

Part Number	Description
7	25"h Horizontal extrusion w/ Velcro attached to Outside Edge
8	25"h Horizontal extrusion w/ Velcro attached to Outside Edge
9a/9b	49.35" Curved extrusion w/ Velcro attached to Inside Edge
10a/10b	49.35" Curved extrusion w/ Velcro attached to Inside Edge
11	25"h Horizontal extrusion w/ Velcro attached to Outside Edge
12	25"h Horizontal extrusion w/ Velcro attached to Outside Edge
13a/13b	49.35" Curved extrusion w/ Velcro attached to Inside Edge
14a/14b	49.35" Curved extrusion w/ Velcro attached to Inside Edge
15	25"h Horizontal extrusion w/ Velcro attached to Outside Edge
16	25"h Horizontal extrusion w/ Velcro attached to Outside Edge
17a/17b	49.35" Curved extrusion w/ Velcro attached to Inside Edge
18a/18b	49.35" Curved extrusion w/ Velcro attached to Inside Edge

Steps

- 1) Connect curved pieces together [a to b].
- 2) Attach horizontal extrusions [7, 8, 11, 12, 15, and 16] between curved vertical assemblies [9, 10, 13, 14, 17, and 18].
- 3) Hook assembled curved frames to top of assembled backwall.
- 4) Connect assembled curved frames together with perforated panels.
- 5) Velcro graphics to front of frames.

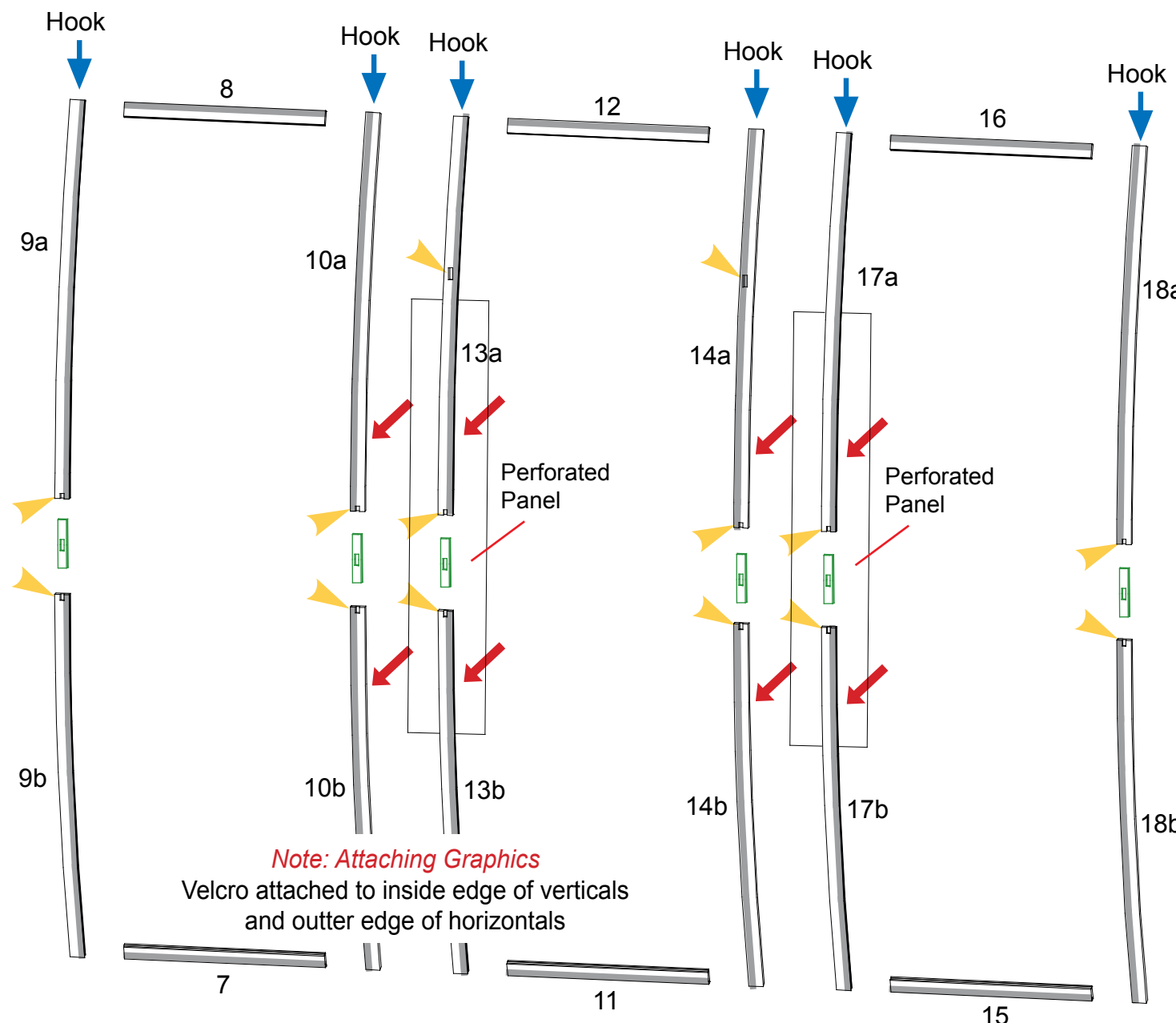
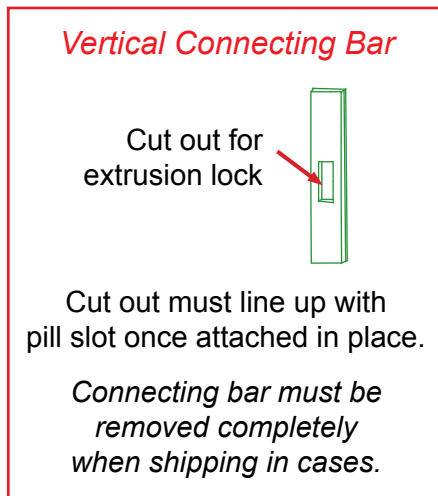
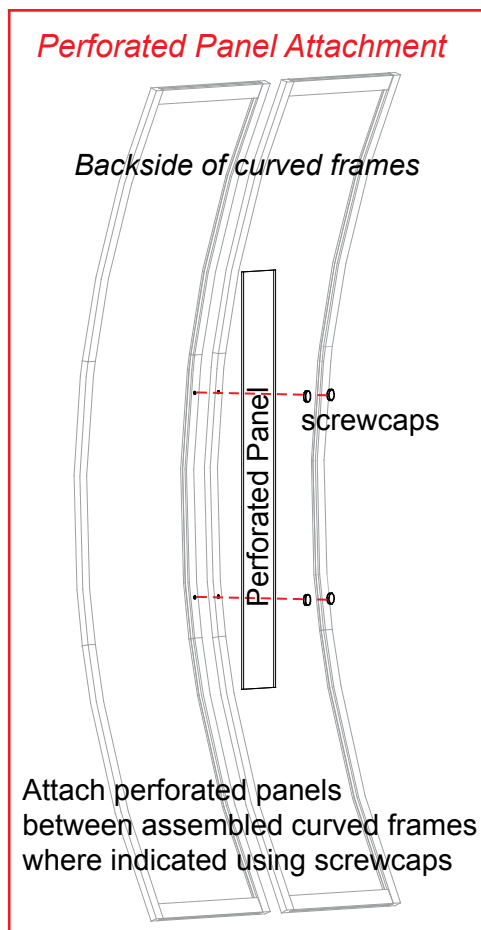

Note: Attaching Graphics
Velcro attached to inside edge of verticals and outer edge of horizontals

- Grey Line indicates Velcro Strip
- Yellow Aero indicates Pill Slot location for extrusion attachment
- Red Aero indicates Hole location on BACK of vertical for standoff attachment



WHEN DISASSEMBLING ALUMINUM EXTRUSION, TIGHTEN ALL SETSCREWS AND LOCKS TO PREVENT LOSS DURING SHIPPING

866.652.2100

Part Number	Description
19	25"h Horizontal extrusion w/ Steel Tape on Outer Edge
20	25"h Horizontal extrusion w/ Steel Tape on Outer Edge
21	41.0499" Curved extrusion w/ Steel Tape on Outer Edge
22	41.0499" Curved extrusion w/ Steel Tape on Outer Edge
23	25"h Horizontal extrusion w/ Steel Tape on Outer Edge
24	25"h Horizontal extrusion w/ Steel Tape on Outer Edge
25	41.0499" Curved extrusion w/ Steel Tape on Outer Edge
26	41.0499" Curved extrusion w/ Steel Tape on Outer Edge
27	25"h Horizontal extrusion w/ Steel Tape on Outer Edge
28	25"h Horizontal extrusion w/ Steel Tape on Outer Edge
29	41.0499" Curved extrusion w/ Steel Tape on Outer Edge
30	41.0499" Curved extrusion w/ Steel Tape on Outer Edge
31	3.5" Horizontal Extrusion

Steps

- 1) Attach horizontal extrusions [19, 20, 23, 24, 27, and 28] between curved vertical extrusions [21, 22, 25, 26, 29, and 30].
- 2) Attach assembled small frames to larger curved frames using extrusion [31] and connecting to the center attachment on both.
- 3) Attach graphic to front side of frame.
- 4) Attach standoff caps to assembled frames.

(NOTE: Outer Frames also have holes for standoff connections but upon setup it was realized that it is very difficult to attach all caps)

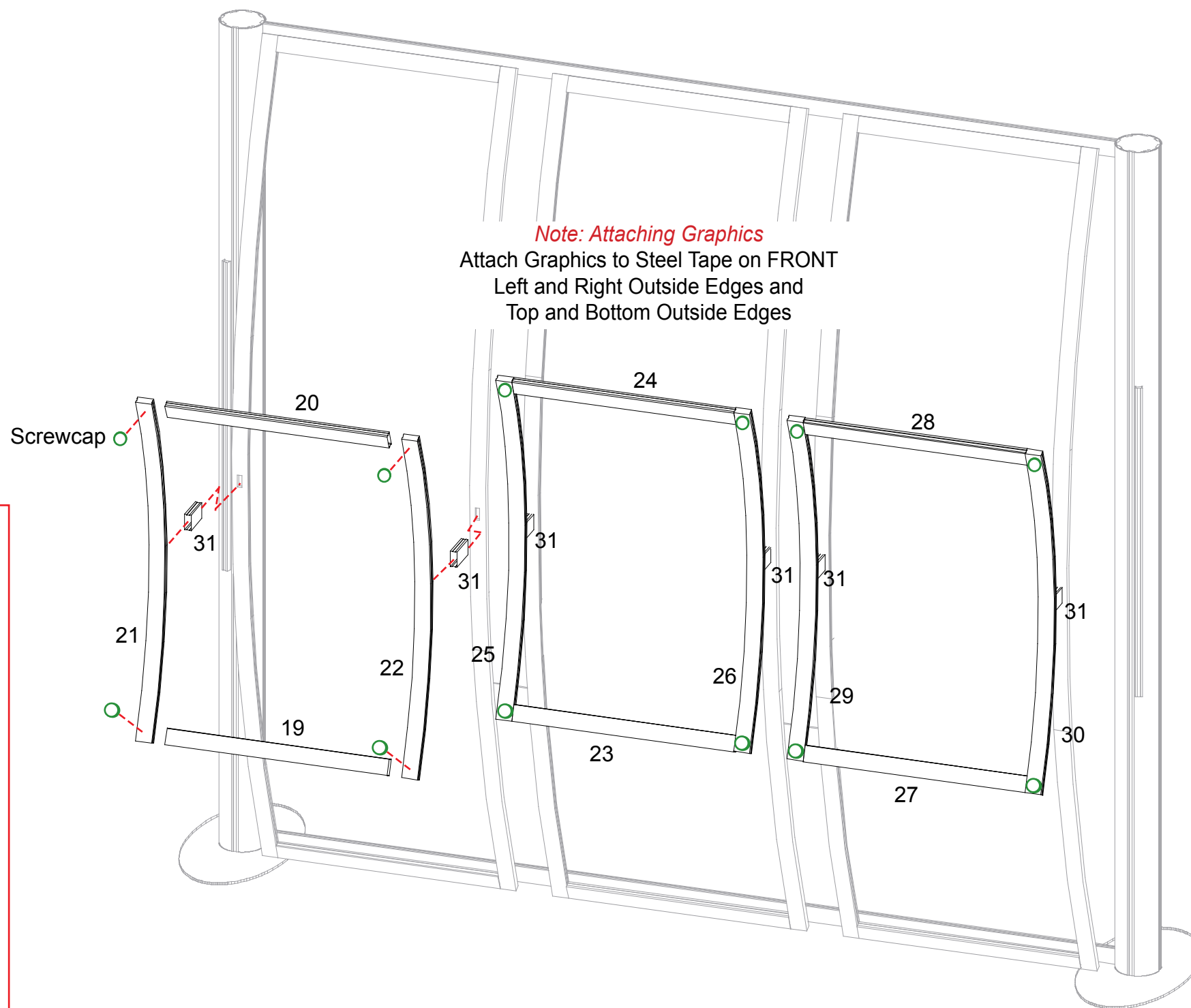
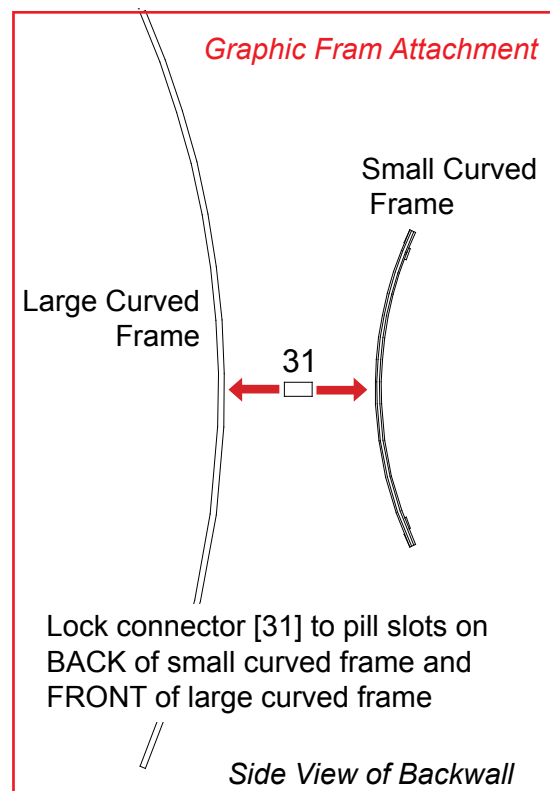

WHEN DISASSEMBLING ALUMINUM EXTRUSION, TIGHTEN ALL SETSCREWS AND LOCKS TO PREVENT LOSS DURING SHIPPING

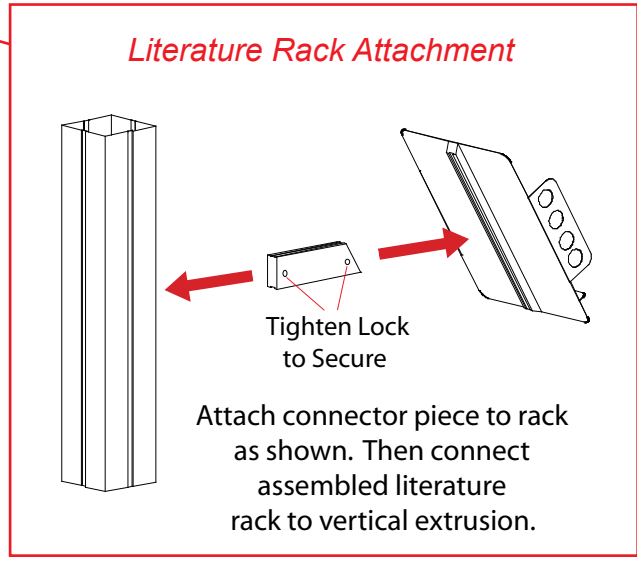
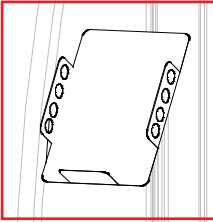
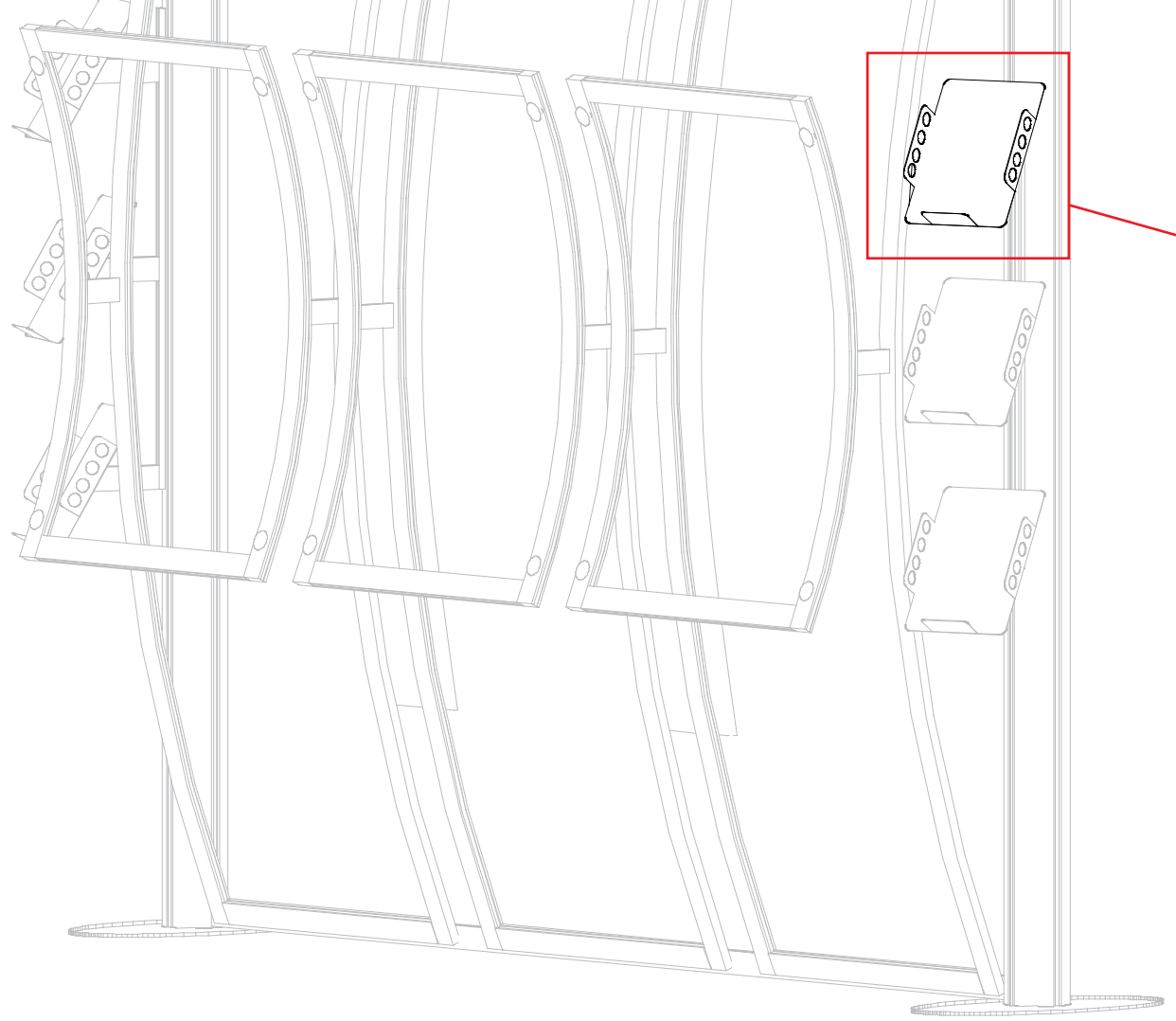
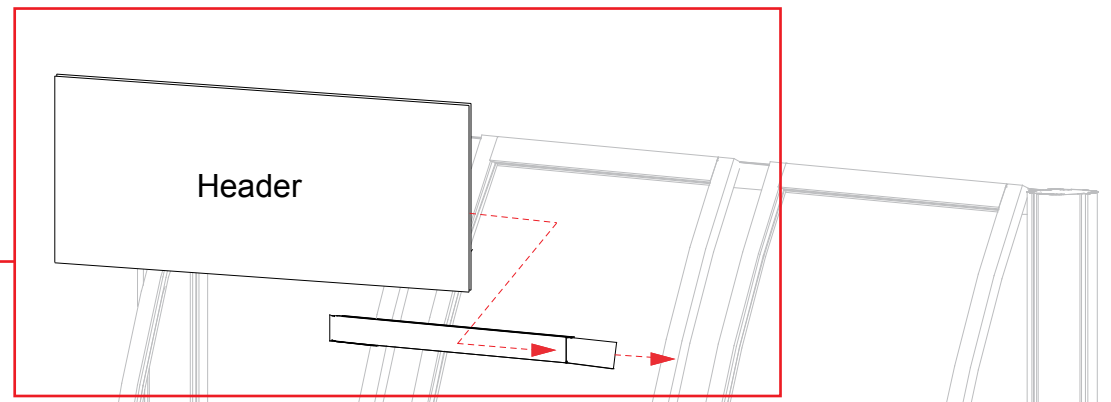
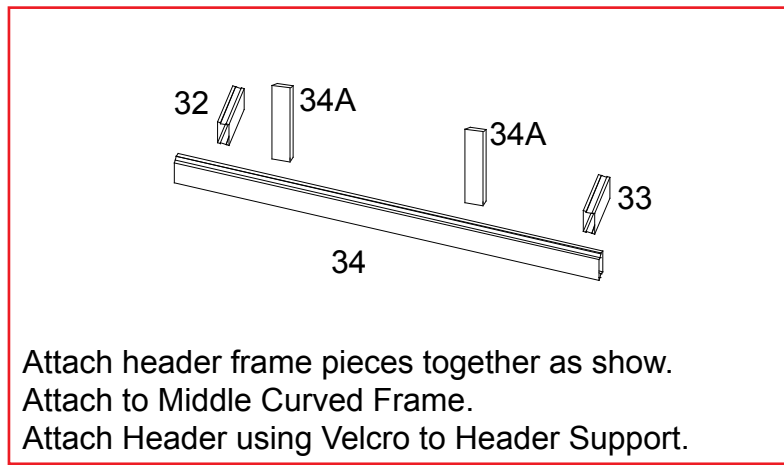

WHEN DISASSEMBLING ALUMINUM EXTRUSION, TIGHTEN ALL SETSCREWS AND LOCKS TO PREVENT LOSS DURING SHIPPING

Modul Extrusion Part List

Item	Qty.	Description
35	1	44.5”h Round Vertical Extrusion w/ Connector Attached
36	1	44.5”h Round Vertical Extrusion
37	4	9.029”w Horizontal Extrusion
38	1	9.029”w Horizontal Extrusion

Euro LT Panel System Part List

Item Number	Description
1	Curve Panel
2	Curve Panel w/ Door
3	Curve Panel

Steps:

- 1) Attach upper extrusions to lower extrusions [36 to 35].
- 2) Attach (2) extrusions [37] between vertical assemblies [35/36], placing insert between horizontals as shown in illustration.
- 3) Assemble counter base by connecting panel #1 to connect on vertical extrusion [35], then continue in numerical order.
- 4) Velcro internal shelf supports to inside of assembled counter base.
- 5) Place internal shelf atop supports.
- 6) Place Counter atop assembled base.
- 7) Attach remaining horizontal extrusions [37 and 38] between vertical assembly, placing inserts where indicated.

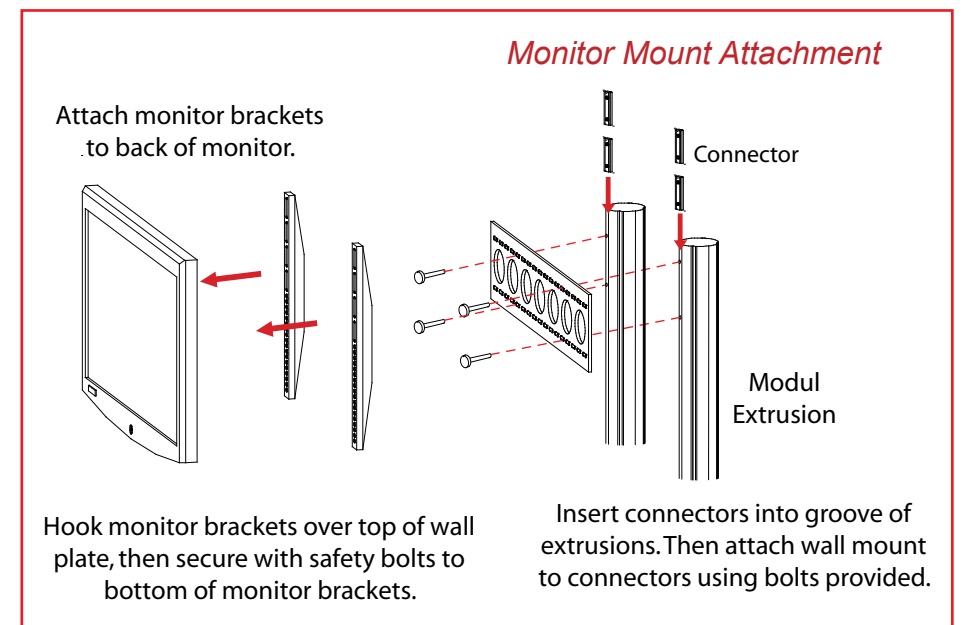
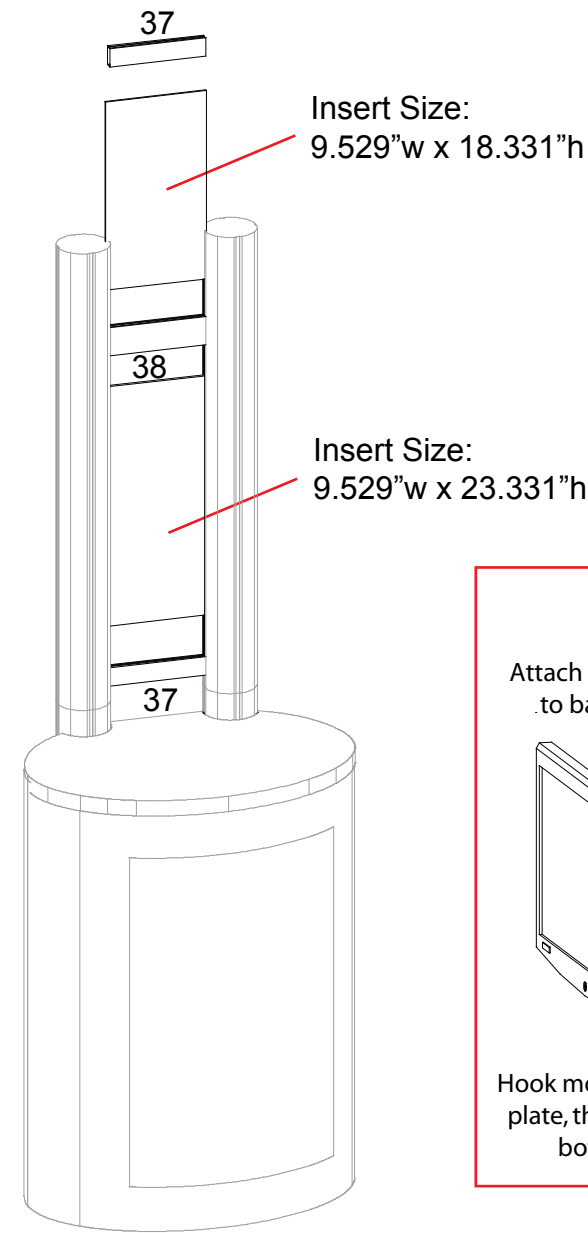
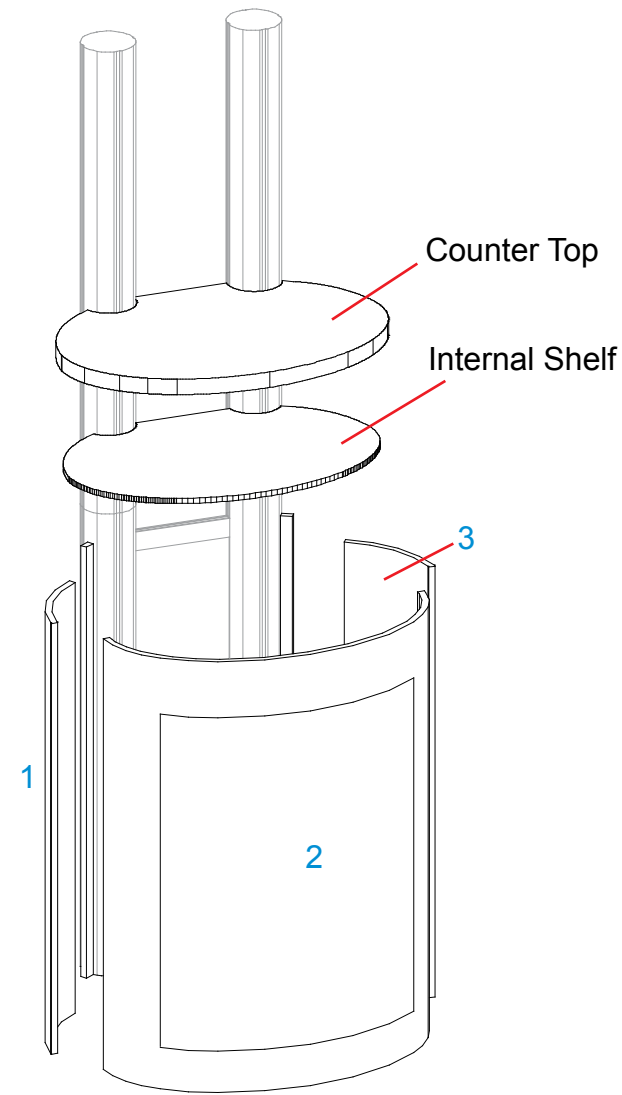
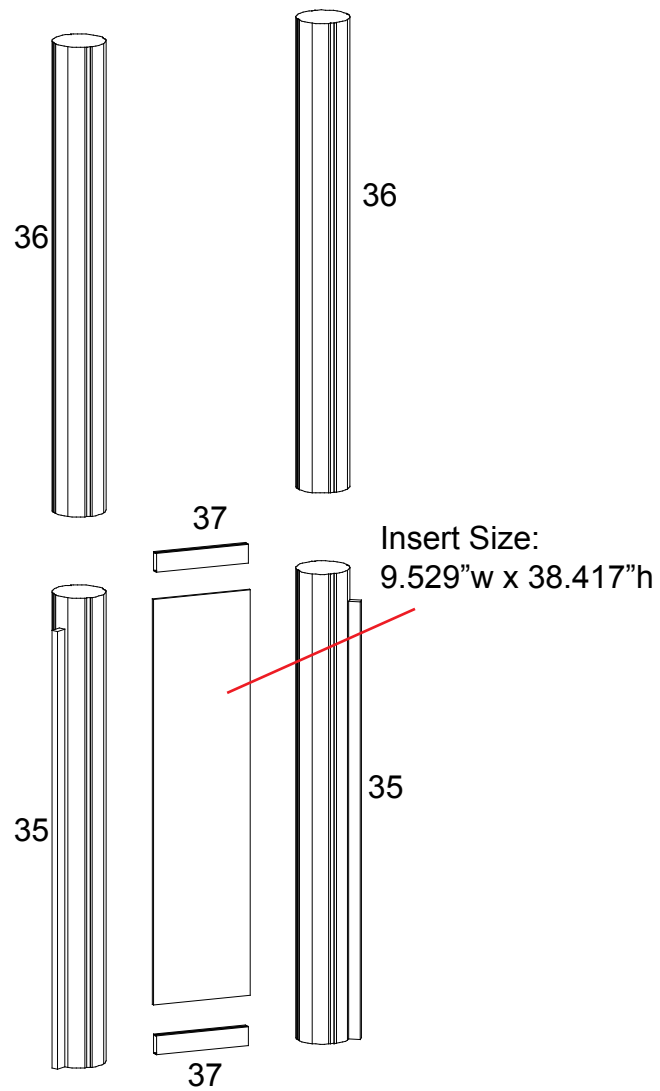

WHEN DISASSEMBLING ALUMINUM EXTRUSION, TIGHTEN ALL SETSCREWS AND LOCKS TO PREVENT LOSS DURING SHIPPING

866.652.2100

LT Panel System: Pedestal Base

Part Number	Description
4	Side Panel
5	Front Panel
6	Side Panel
7	Back Panel with Door

Steps

- 1) Connect podium panels together in numerical order.
- 2) Velcro internal shelf supports to inside of assembled base.
- 3) Place internal shelf atop supports.
- 4) Place counter top atop assembled base.
- 5) Attach upper Plexi shelf to top of counter using stand-offs.

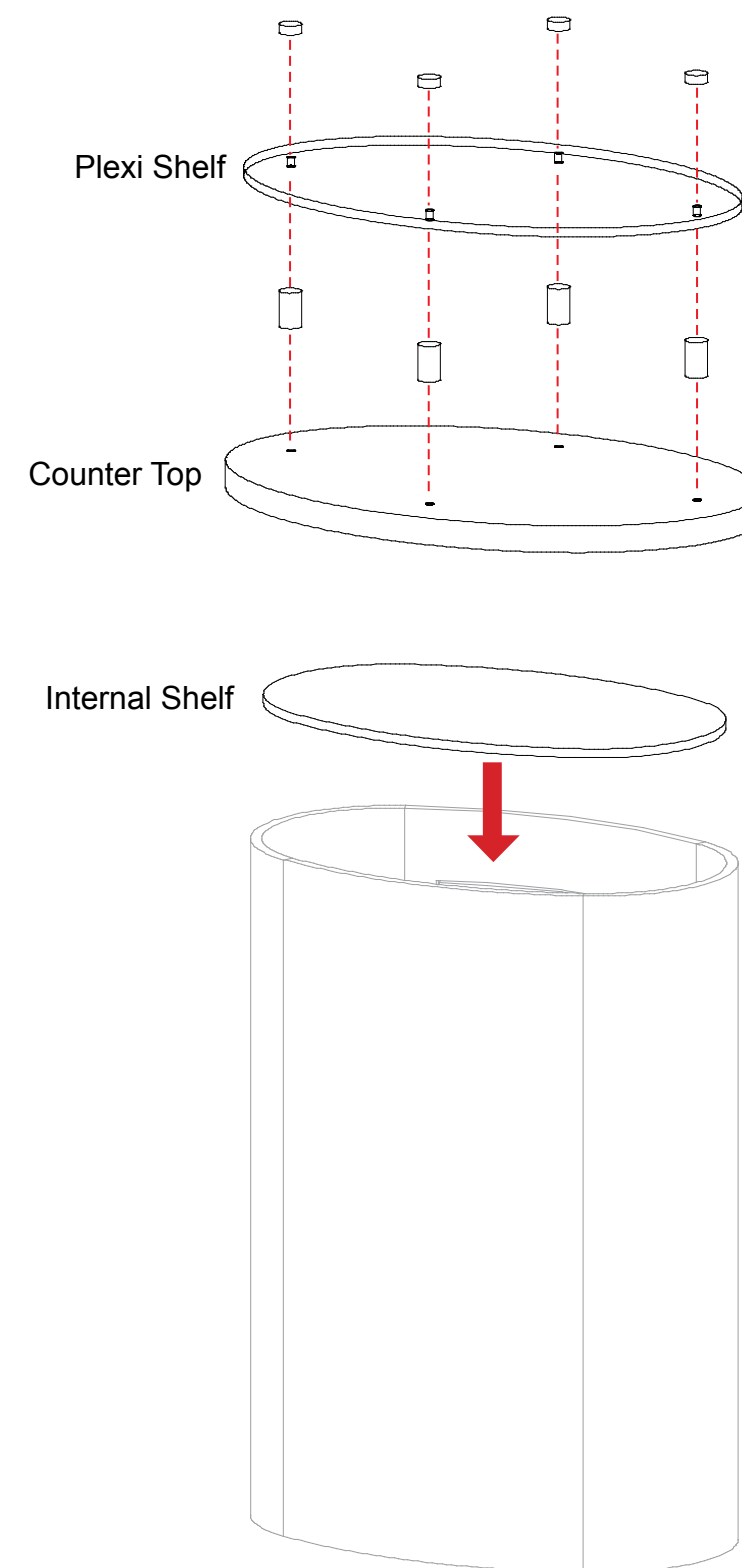
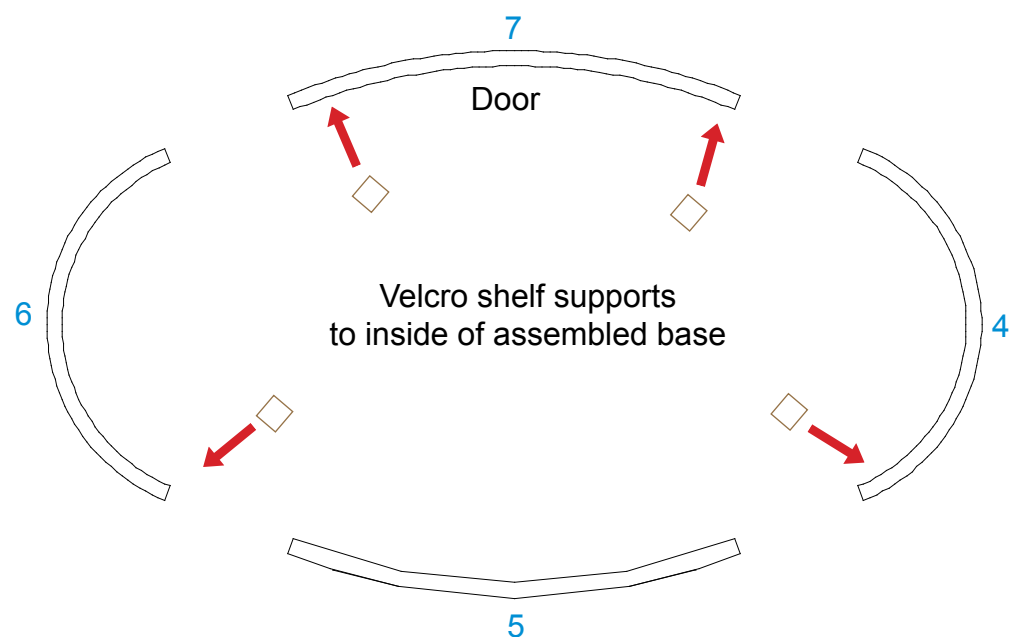

WHEN DISASSEMBLING ALUMINUM EXTRUSION, TIGHTEN ALL SETSCREWS AND LOCKS TO PREVENT LOSS DURING SHIPPING

