

AERO

Using Your Setup Instructions

The Aero Overhead Sign Setup Instructions are created specifically for your configuration. They include an exploded view of the frame which is sequentially numbered. We encourage you to study the instructions before attempting to assemble your exhibit.

Connections are kept very simple: no tools. Everything assembles with push-button connectors and pre-connected horizontal sections.

Cleaning and Packing Your Display

- 1) Use care when cleaning aluminum extrusion or acrylic inserts. Use only non-abrasive cleaners.
- 2) Retain all packing material. It will make re-packing much easier and will reduce the likelihood of shipping damage.

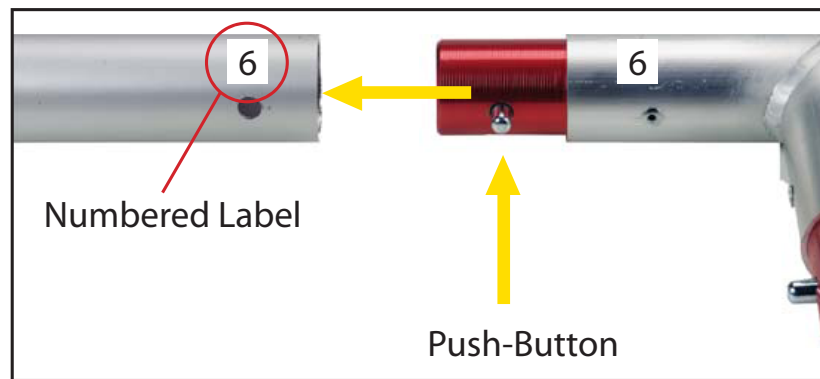

Connections are made by holding the button down and sliding the red tube into opposing tube until the connection is made. To disassemble push button and pull or twist extrusions apart.

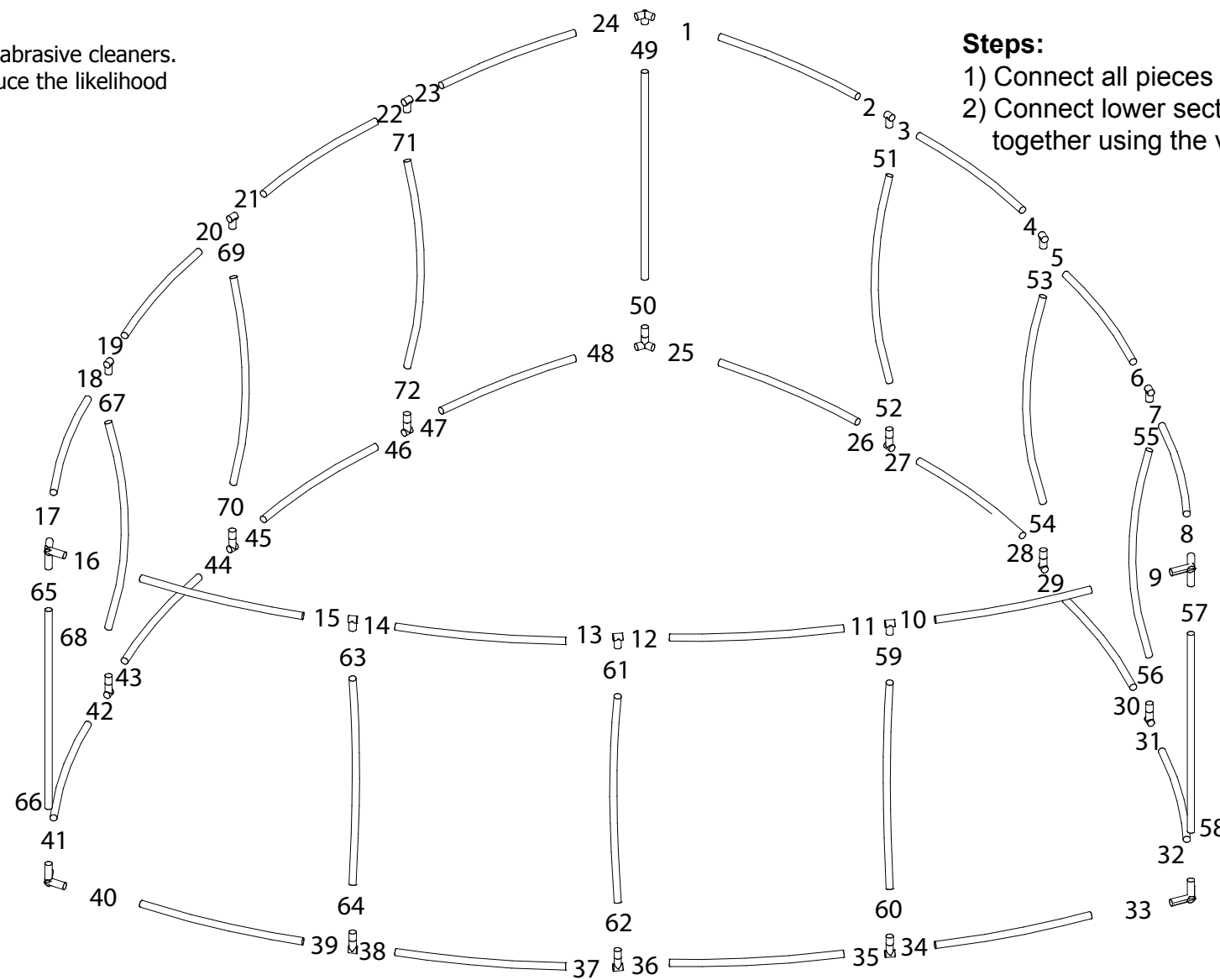
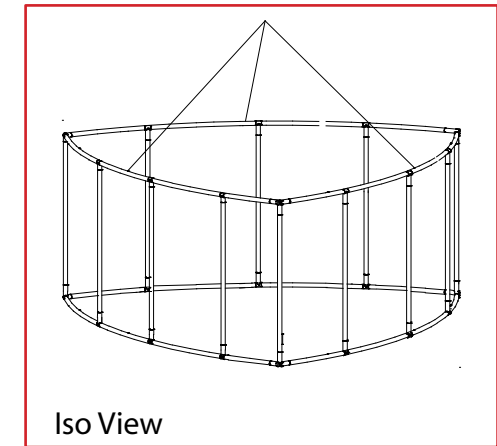
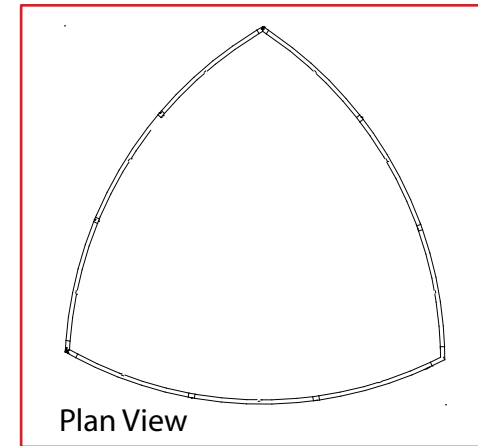
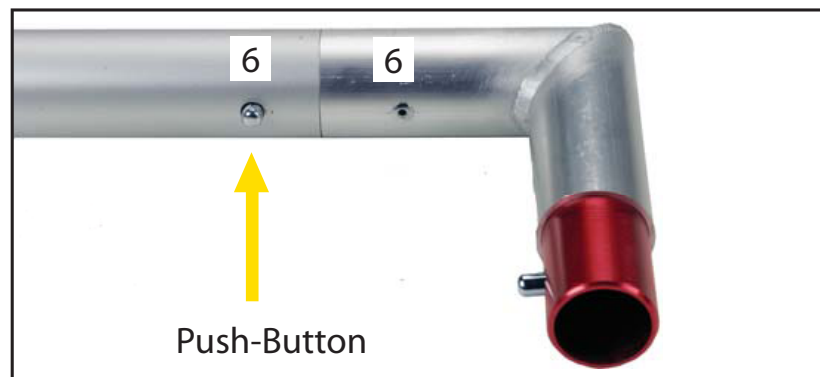

Steps:

- 1) Connect all pieces together in numerical order.
- 2) Connect lower section and upper section together using the vertical supports.

NOTE :

PDF copies of your Setup Instructions are available @ www.classicexhibits.com
 Use the Search Tool located on the lower left-hand corner of the Classic Home
 Enter your 5-7 digit Order #.

Search for Setup Instructions

866.652.2100

Engineering Specifications

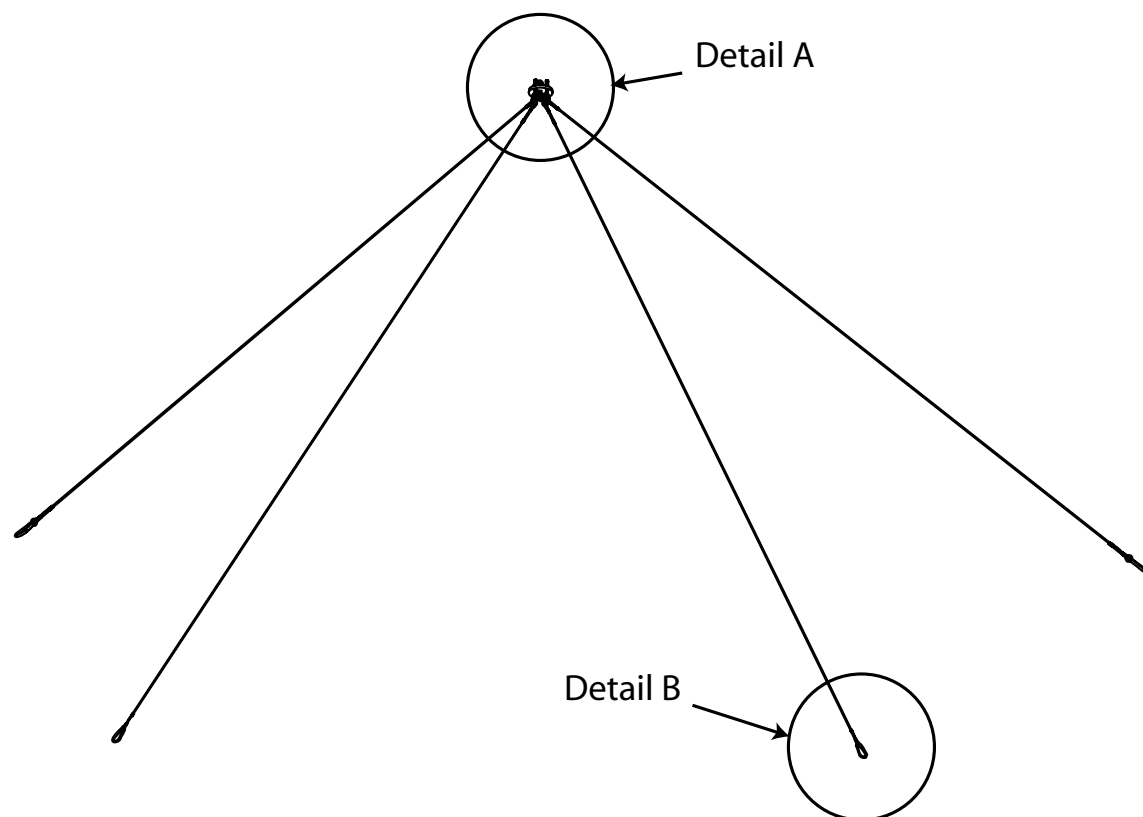

Harness Strength Calculation

Hanging sign weight is calculated based on weight of the structure and the weight of the fabric:

1. The weight of the structure material is 0.29 lbs per linear feet
2. The weight of the fabric is 0.04 lbs per sq. feet

Based on information above, one string of the harness at a standard 45 degree sling angle will accommodate 163 sq. feet surface measured sign. The vertical string will hold 233 sq. feet surface measured sign.

NOTE: If motor used for rotation, see motor specification.

Construction consists of the following materials:

1. 302/304 (1/8") Stainless Steel Cable (Rated at 1760 lbs break strength)
2. Plated Spring-loaded Interlocking Snaps (Rated at 280 lbs working load)
3. Nicoperss Oval Sleeves (Holding strength rated at 900 lbs)
4. 0.25" x 4" Diameter T6061 Aluminum Plate
5. Eye Bolts (Rated 900 lbs on vertical lift and 450 lbs on 45 degree lift)

Detail A

Harness Head Assembly

Classic Rotating Motor Specifications
**Optional

**MODEL IG-4 HANGING ROTATOR
(NO SPINNING POWER CORD)
PART # 150001 021HANG**

HANGING WEIGHT CAPACITY: 200 LBS.
AVAILABLE RPM SPEEDS: 1, 2(STD), 3, 4, 6
MOTOR DRAW: 0.1A (12w)
SAFETY CLUTCH: YES

MK	Qty	Desc
10e	1	.313 Nylok Hex Nut
10c	2	.125 Copper Stop 520-20040
10f	1	.313 Kidney Snap 434-24905
		Typical 4 Places

****Complete *Engineering Certifications* are available at www.classicexhibits.com. Use the "Search for Setup Instructions Tool" on the Classic Home Page (lower left-hand corner).**

Enter this 5 digit #

11111

search

Search for Setup Instructions