

20'

20'

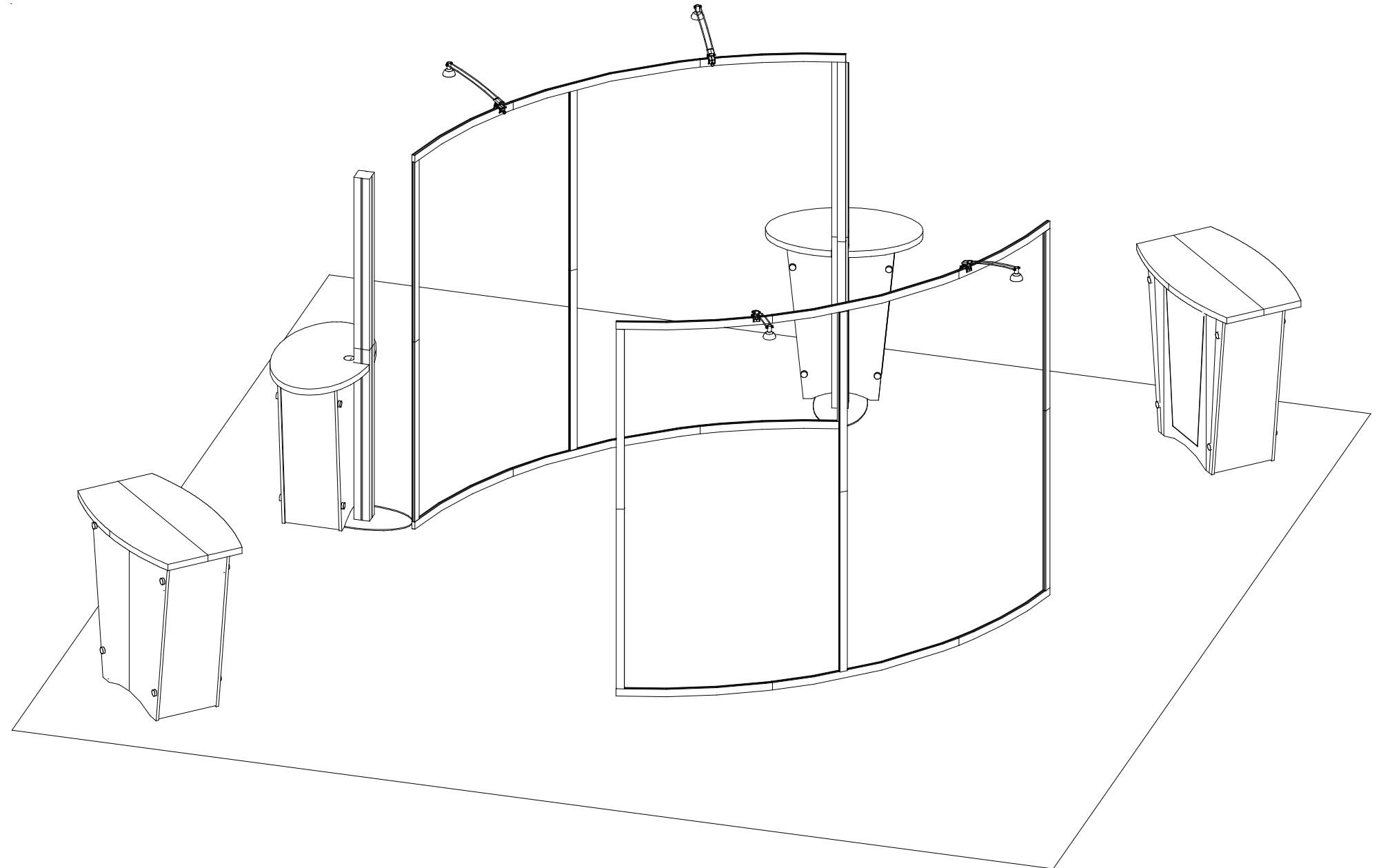

WHEN DISASSEMBLING ALUMINUM EXTRUSION, TIGHTEN ALL SETSCREWS AND LOCKS TO PREVENT LOSS DURING SHIPPING

visionary™ IDESIGNS

Using Your Setup Instructions

The Visionary Designs Setup Instructions are created specifically for your configuration. They are laid out sequentially, including an exploded view of the entire display, and then a logical series of detailed steps to assemble the main structure and components. We encourage you to study the instructions **before** attempting to assemble your exhibit.

Each page reminds you to tighten the setscrews after disassembling your exhibit to prevent loss of the locks and setscrews (see below in RED). This is **VERY IMPORTANT**.

Cleaning and Packing Your Display

- 1) Use care when cleaning aluminum extrusion or acrylic inserts. Use only non-abrasive cleaners.
- 2) When cleaning laminate inserts or countertops, use mild cleansers and a soft material such as cotton.
- 3) Keep all display components away from extreme heat and long exposure to sunlight to avoid warping and fading.
- 4) Retain all packing material. It will make re-packing much easier and will reduce the likelihood of shipping damage.



The Tool

Most Visionary Designs exhibits can be assembled with the supplied Hex Key Tool. Occasionally, a flat head screwdriver may be required.



Detail A

Typical Connection



Typical Connection (cont'd)

Most horizontal extrusion connections have a patented expandable lock. This lock inserts into the groove of an opposing extrusion. Tightening the lock with the Hex Key Tool expands the lock and creates a strong positive connection.



Detail B

Numbered Label

Each extrusion contains a numbered label which corresponds with setup instructions. The label is located within a groove of the extrusion (when possible). With Visionary Designs the labels contain Black numbers unless otherwise specified.



Detail C

Horizontal Inline Connection (remove only one setscrew)

Remove only (1) setscrew when disassembling. Replace setscrew in extrusion after assembling it. Before packing, replace setscrew in extrusion to avoid losing it.

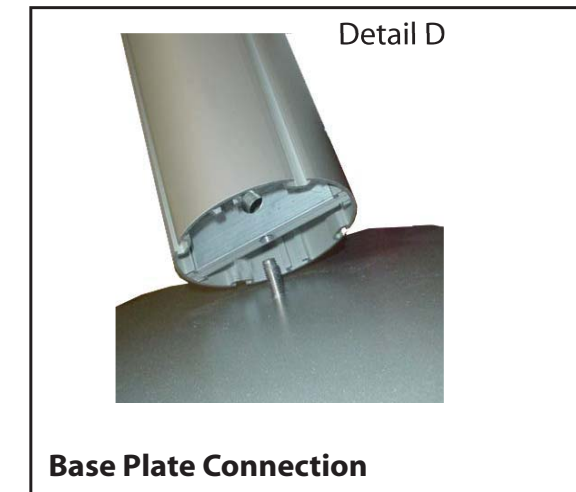

Detail D

Base Plate Connection

Attach base plate to round or square vertical extrusion using the bolt provided. Be careful not to strip the threads.

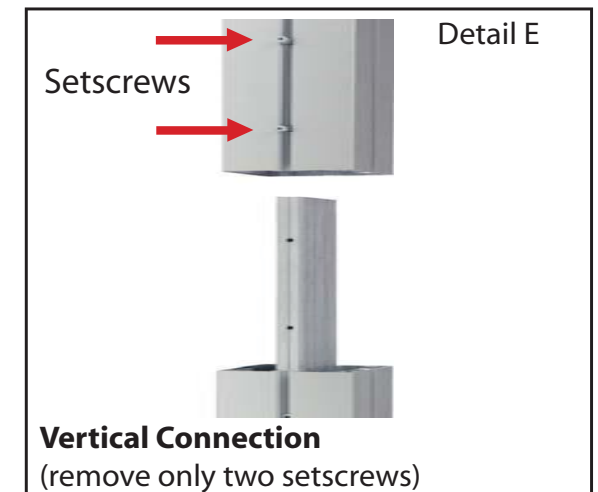

Detail E

Vertical Connection
(remove only two setscrews)

When vertical extrusions are packed in portable cases rather than crates or tubs, they must be broken down into smaller sections which then require assembly.

Remove only (2) setscrews when disassembling. Replace setscrews in extrusion after assembling it. Before packing, replace setscrews in extrusion to avoid losing them.

WHEN DISASSEMBLING ALUMINUM EXTRUSION, TIGHTEN ALL SETSCREWS AND LOCKS TO PREVENT LOSS DURING SHIPPING

866.652.2100

Item	Qty.	Description
1a/1b/1c	1/1/1	38.2049" w Curved Horizontal Extrusion
2a/2b/2c	1/1/1	38.2049" w Curved Horizontal Extrusion
3a/3b	1/1	44.1465" h Vertical Extrusion
4a/4b	1/1	44.1465" h Vertical Extrusion
5a/5b	1/1	44.1465" h Vertical Extrusion

- Steps:
- 1) Connect vertical and horizontal pieces together as shown.
 - 2) Connect vertical assemblies between horizontal assemblies as shown.
 - 3) Attach lights to top of assembled frame.

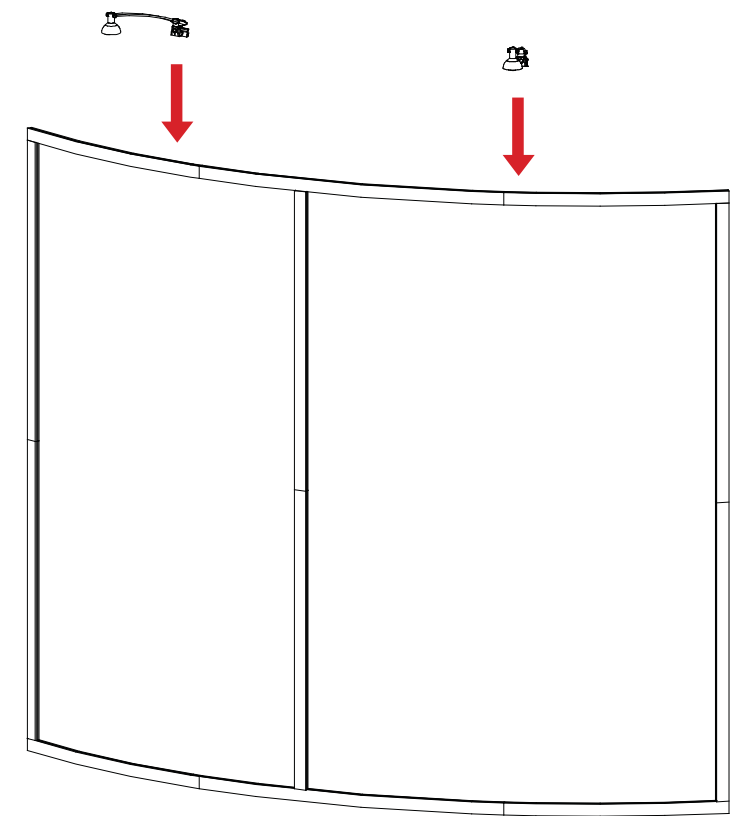
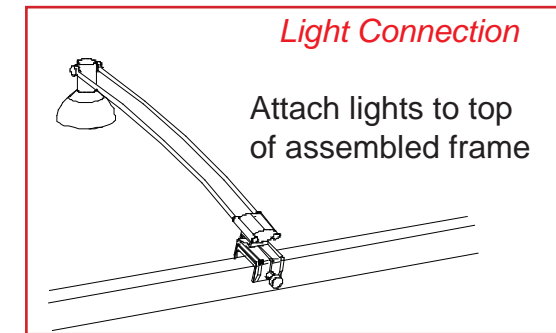
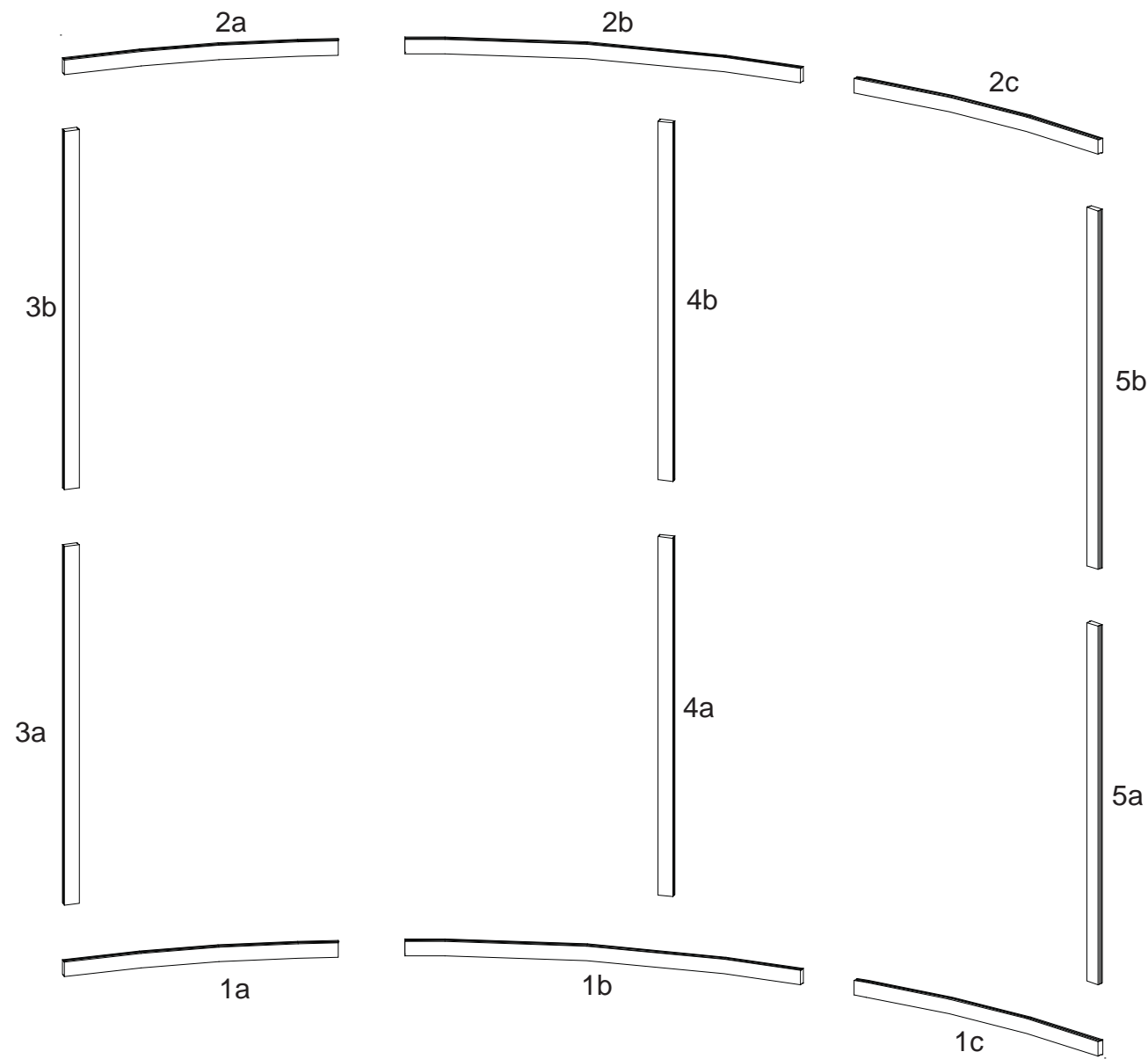

WHEN DISASSEMBLING ALUMINUM EXTRUSION, TIGHTEN ALL SETSCREWS AND LOCKS TO PREVENT LOSS DURING SHIPPING

Item	Qty.	Description
1a/1b/1c	1/1/1	38.2049" w Curved Horizontal Extrusion
2a/2b/2c	1/1/1	38.2049" w Curved Horizontal Extrusion
3a/3b	1/1	44.1465" h Vertical Extrusion
4a/4b	1/1	44.1465" h Vertical Extrusion
5a/5b	1/1	44.1465" h Vertical Extrusion

Steps:

- 1) Connect vertical and horizontal pieces together as shown.
- 2) Connect vertical assemblies between horizontal assemblies as shown.
- 3) Attach lights to top of assembled frame.

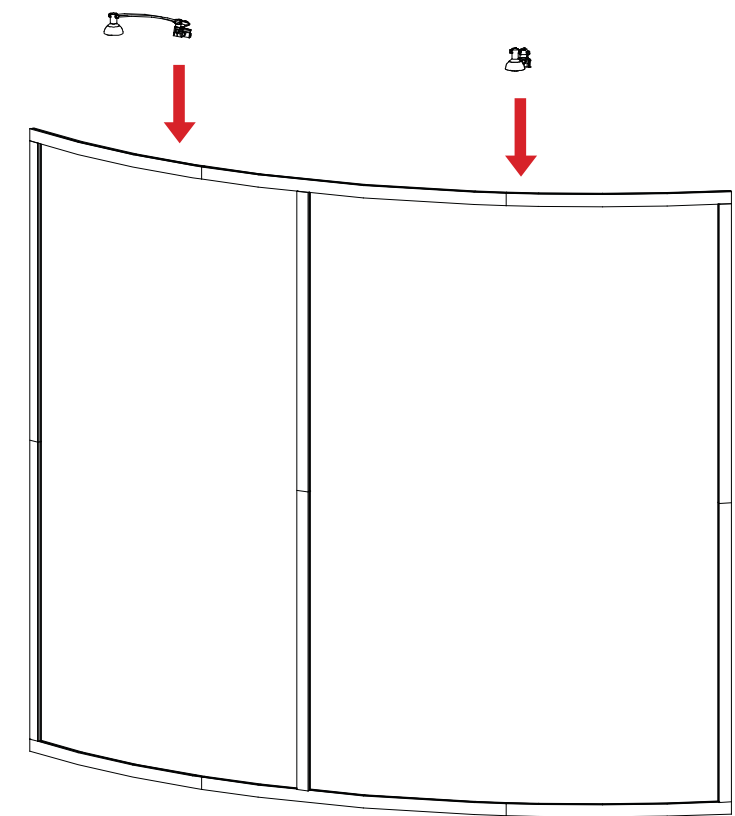
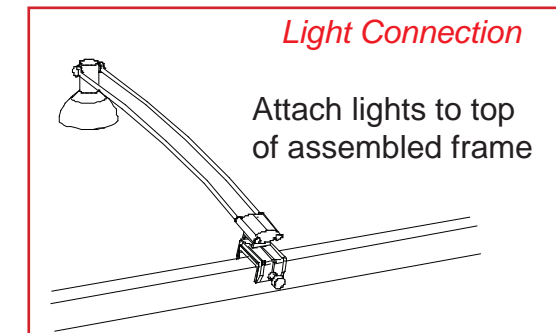
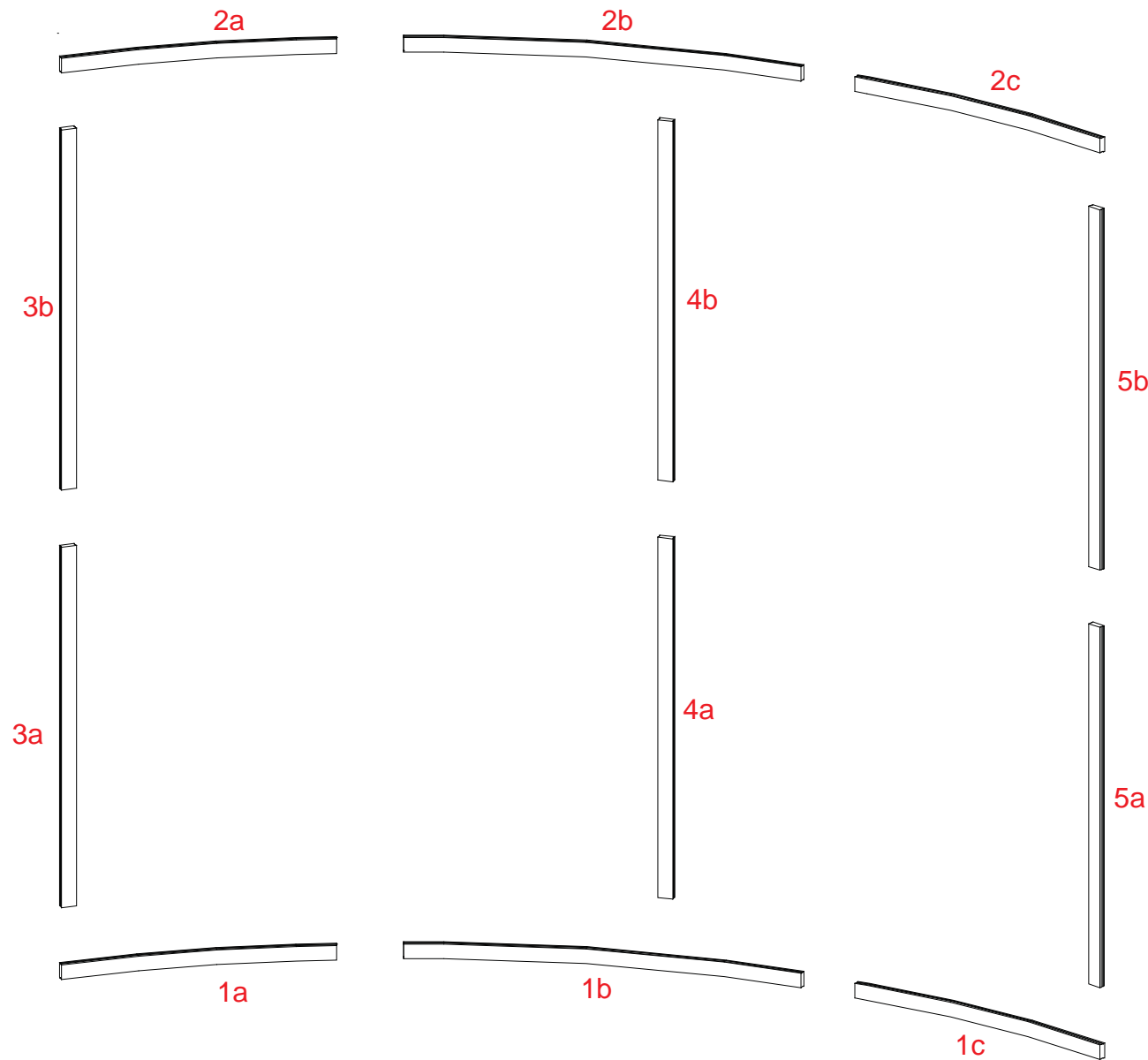

WHEN DISASSEMBLING ALUMINUM EXTRUSION, TIGHTEN ALL SETSCREWS AND LOCKS TO PREVENT LOSS DURING SHIPPING

866.652.2100

Item	Qty.	Description
6	1	Base Plate
7	1	Lower Square Extrusion
8	1	Upper Square Extrusion

Steps:

- 4) Connect upper and lower vertical extrusions together.
- 5) Using door opening, attach assembled vertical extrusion to back panel of assembled pedestal base using bolts.
- 6) Place counter top on assembled pedestal base.

Steps:

- 1) Use standoff screws to secure the front panel with door and back panel of the pedestal to the side panels.
- 2) After assembling front, back, and side panels, slide floor into the bottom of the pedestal. The floor will sit on pins on the inside of the side panels.
- 3) After floor is in place, use velcro attachments to install shelf.

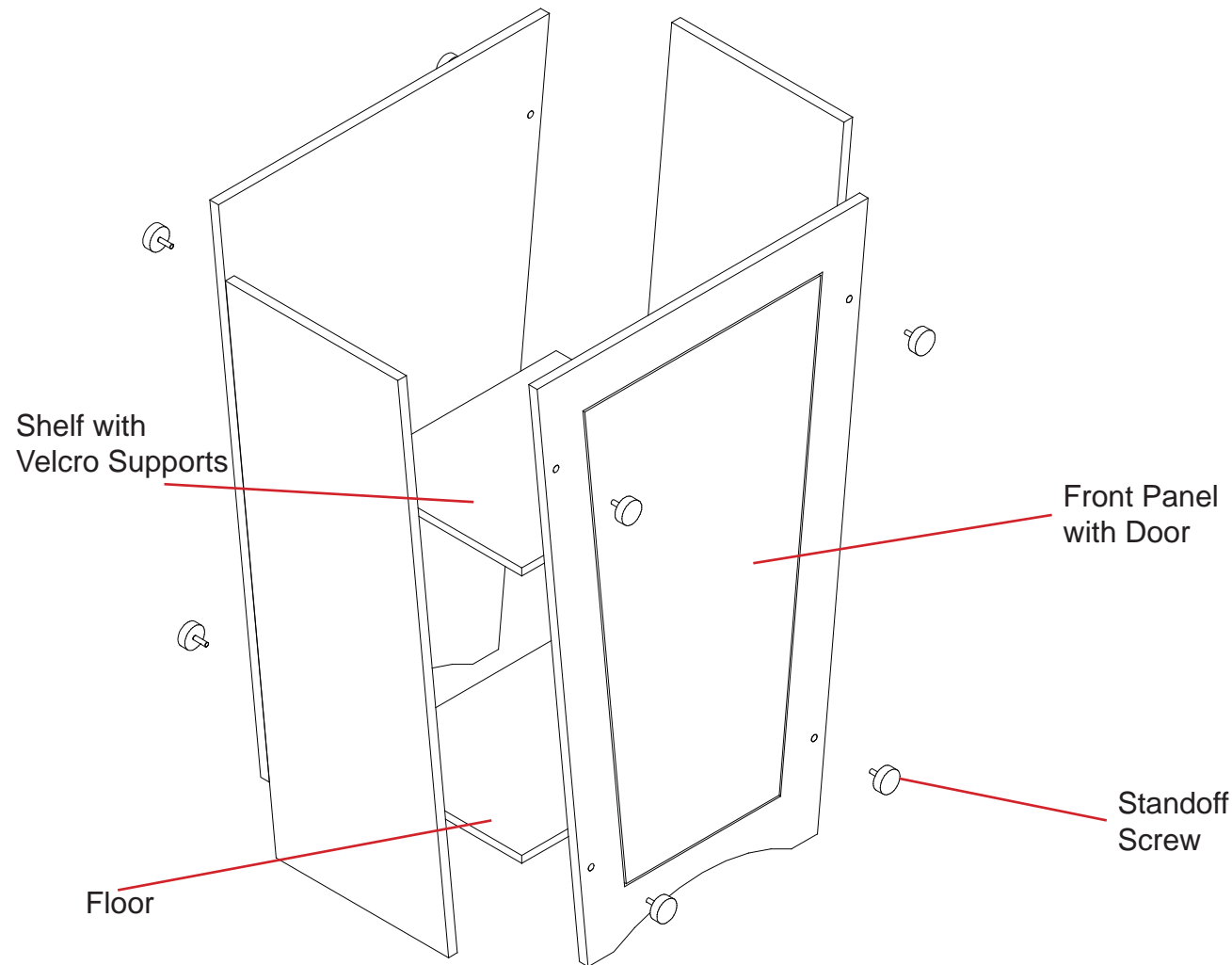

Attach the oval counter top to the pedestal base.

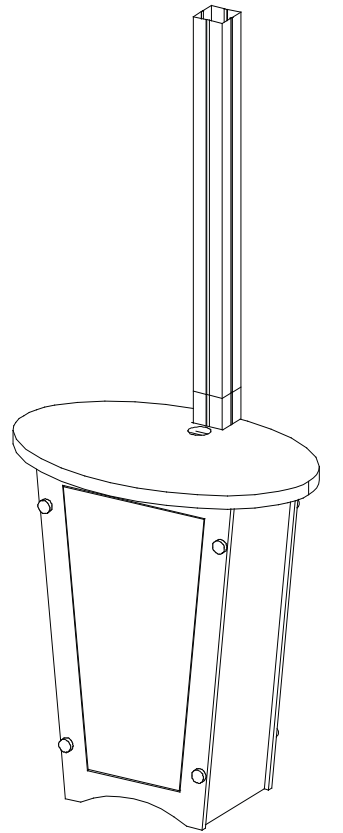
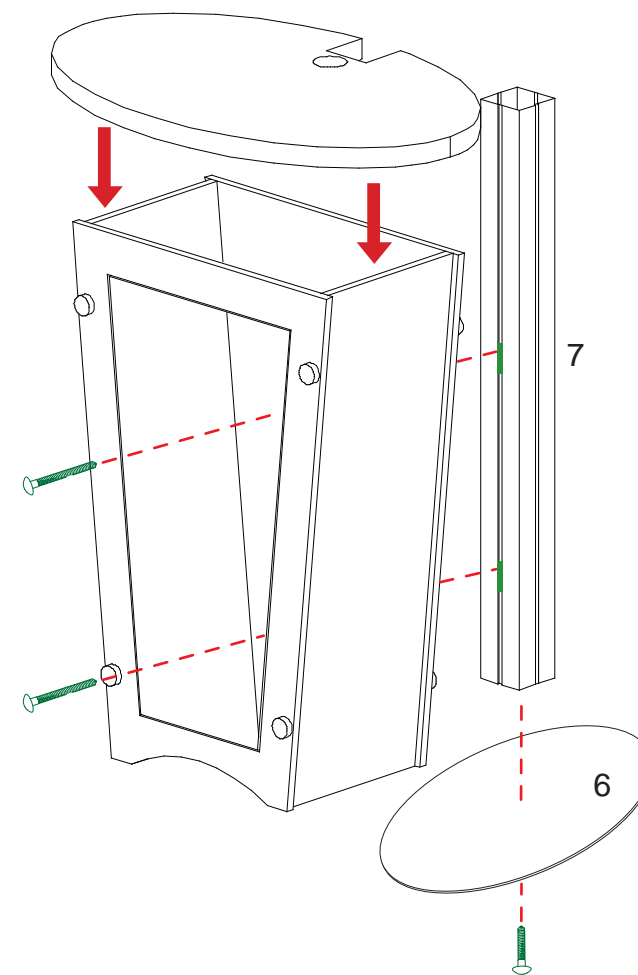

Monitor Mount Attachment

Connectors

Attach back plate to connectors on vertical extrusion using screws. Then attach top plate and tighten setscrews to secure.

WHEN DISASSEMBLING ALUMINUM EXTRUSION, TIGHTEN ALL SETSCREWS AND LOCKS TO PREVENT LOSS DURING SHIPPING

866.652.2100

Item	Qty.	Description
6	1	Base Plate
7	1	Lower Square Extrusion
8	1	Upper Square Extrusion

Steps:

- 4) Connect upper and lower vertical extrusions together.
- 5) Using door opening, attach assembled vertical extrusion to back panel of assembled pedestal base using bolts.
- 6) Place counter top on assembled pedestal base.

Steps:

- 1) Use standoff screws to secure the front panel with door and back panel of the pedestal to the side panels.
- 2) After assembling front, back, and side panels, slide floor into the bottom of the pedestal. The floor will sit on pins on the inside of the side panels.
- 3) After floor is in place, use velcro attachments to install shelf.

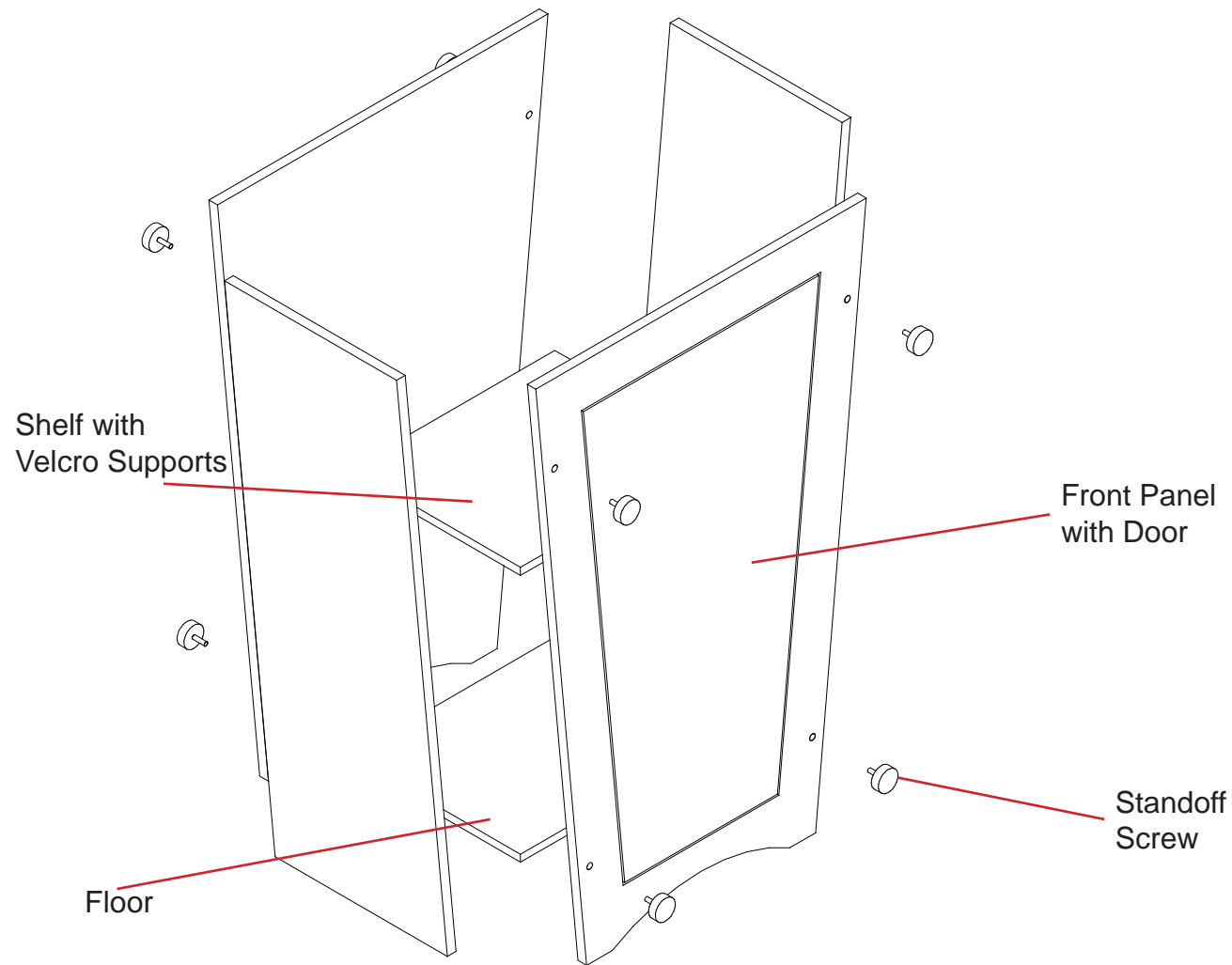

Attach the oval counter top to the pedestal base.

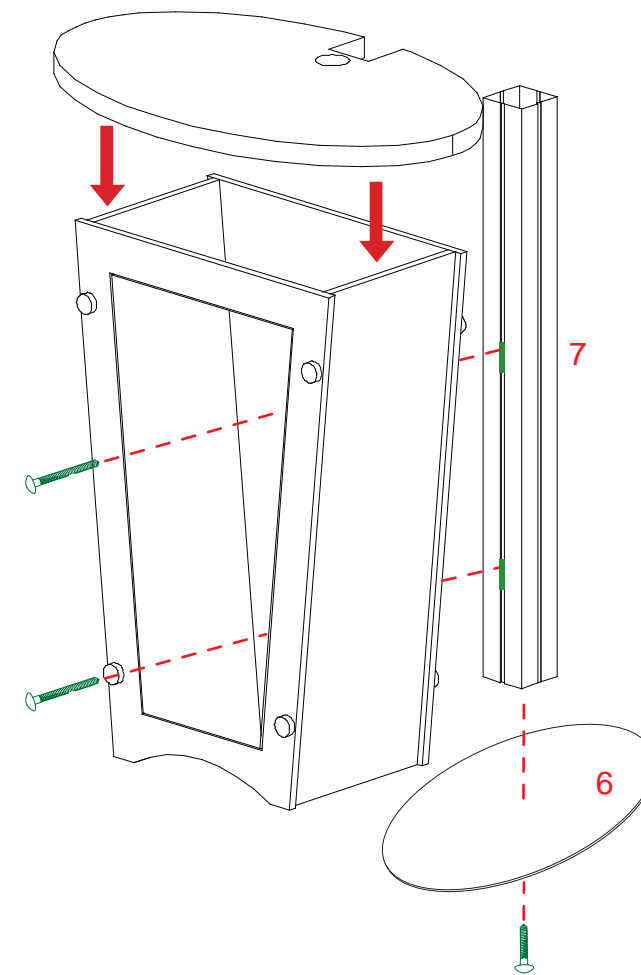

Monitor Mount Attachment

Connectors

Attach back plate to connectors on vertical extrusion using screws. Then attach top plate and tighten setscrews to secure.

WHEN DISASSEMBLING ALUMINUM EXTRUSION, TIGHTEN ALL SETSCREWS AND LOCKS TO PREVENT LOSS DURING SHIPPING

866.652.2100

Setup Instructions:

- A) Use standoff screws to secure the front panels with door and back panels of the pedestal to the side panels.
- B) After assembling front, back, and side panels, slide floor into the bottom of the pedestal. The floor will sit on pins on the inside of the side panels.

Hanging Rod Support Attachment

Screw rod supports to panels 2 and 4 as shown. Insert one end of rod to O-shape support then rest the other end on U-shape support.

**** Remove rod supports when shipping ****

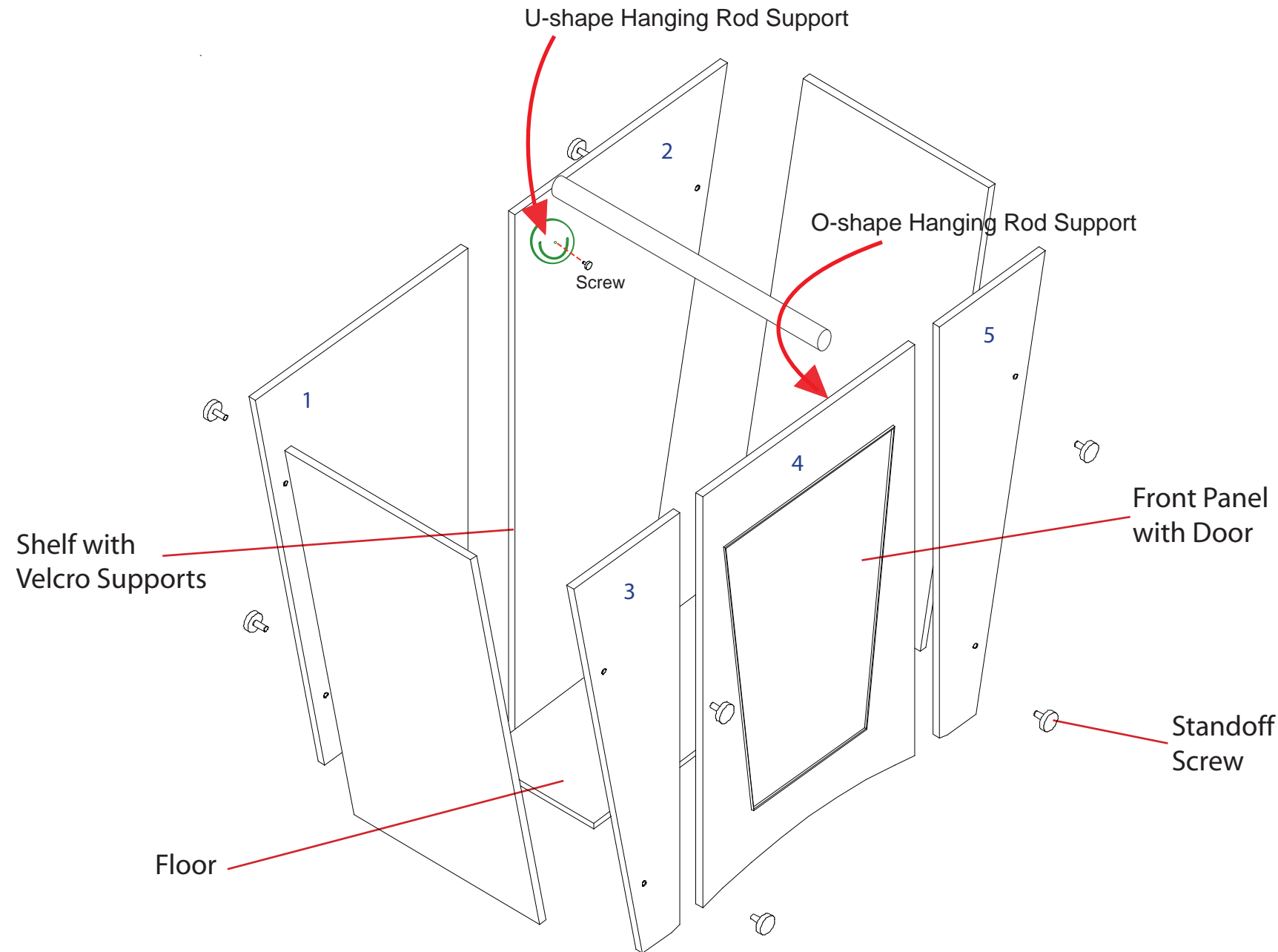
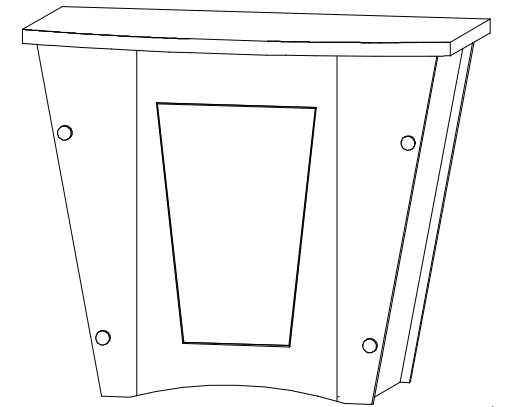

Attach the counter top to the pedestal base.

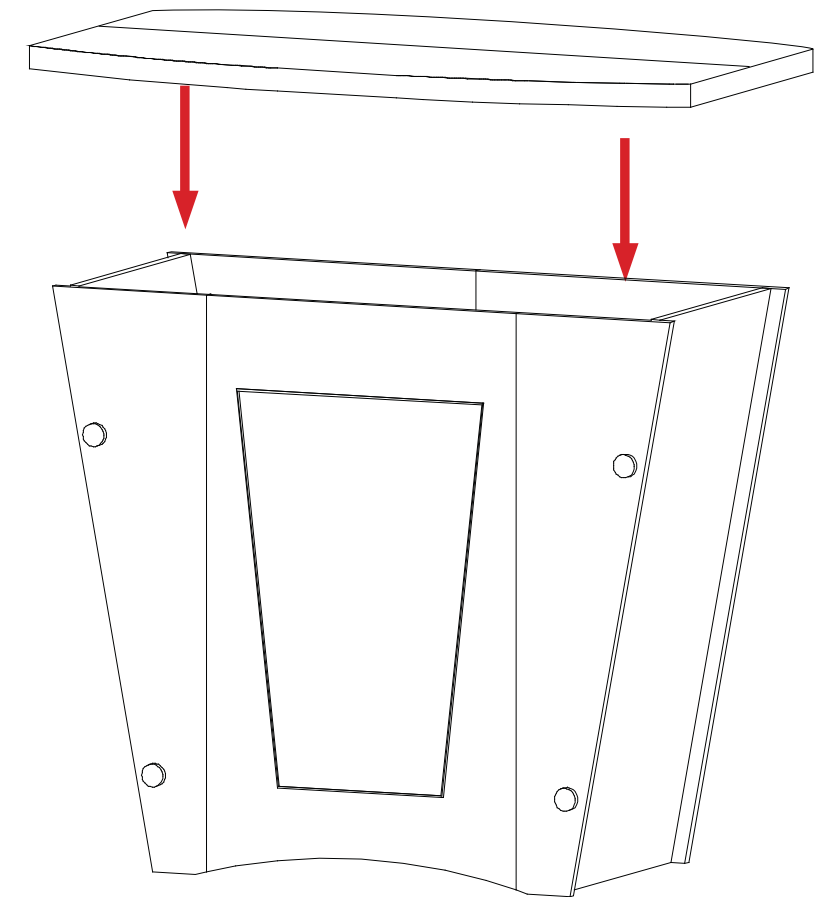

WHEN DISASSEMBLING ALUMINUM EXTRUSION, TIGHTEN ALL SETSCREWS AND LOCKS TO PREVENT LOSS DURING SHIPPING

Top View of each Level

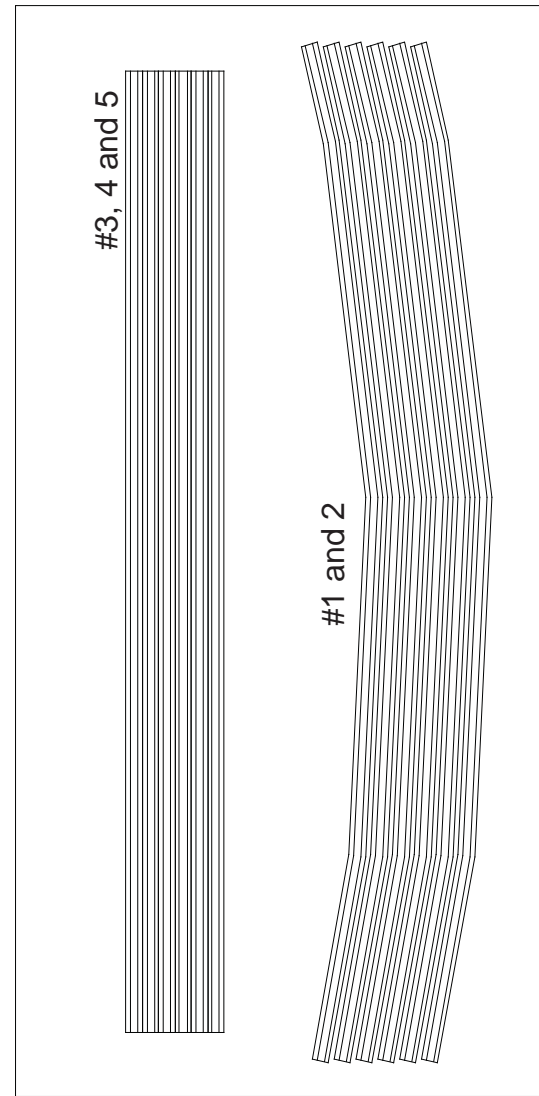

Level 1

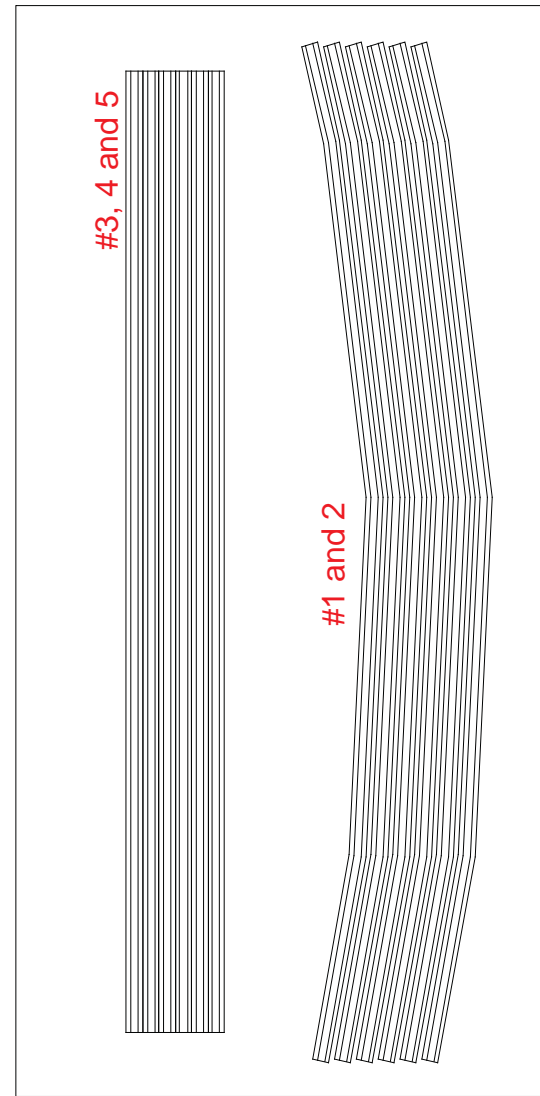

Level 2

Setup Hardware

WHEN DISASSEMBLING ALUMINUM EXTRUSION, TIGHTEN ALL SETSCREWS AND LOCKS TO PREVENT LOSS DURING SHIPPING

Top View of each Level

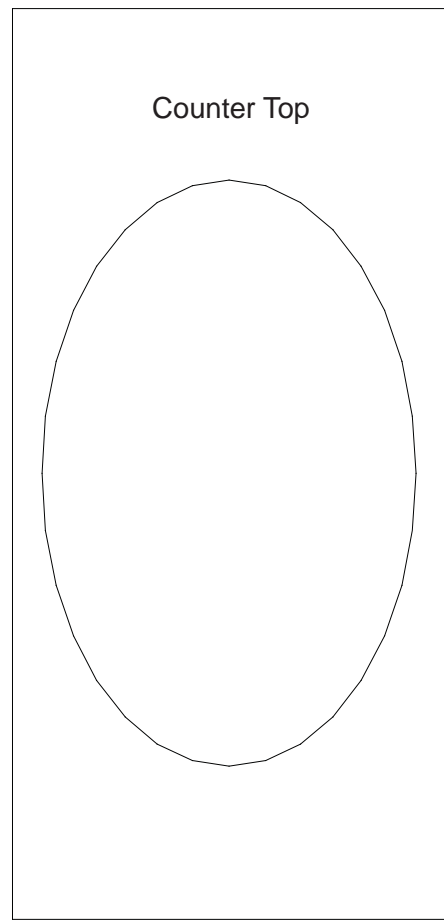

Level 1

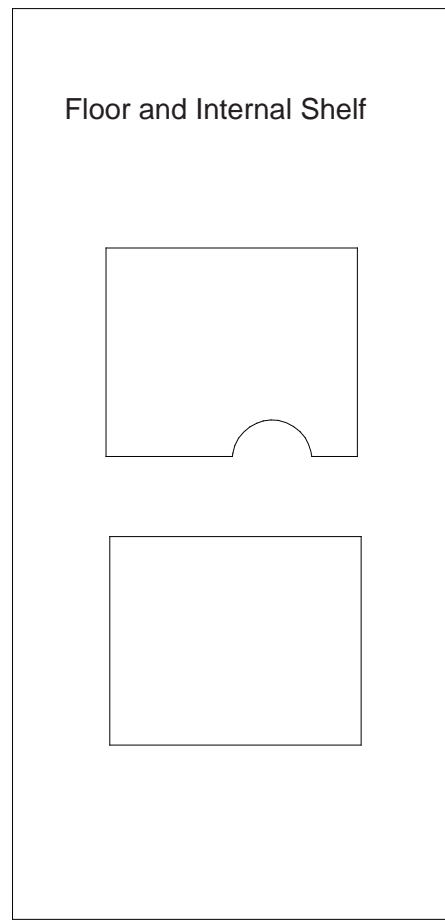

Level 2

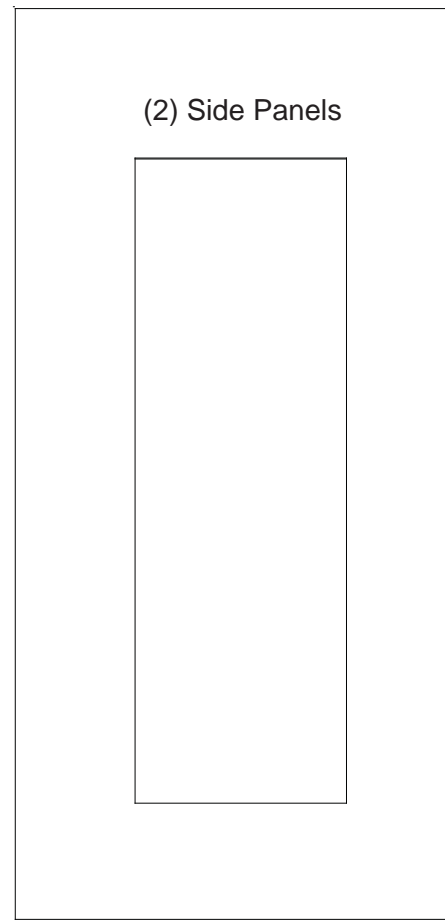

Level 3

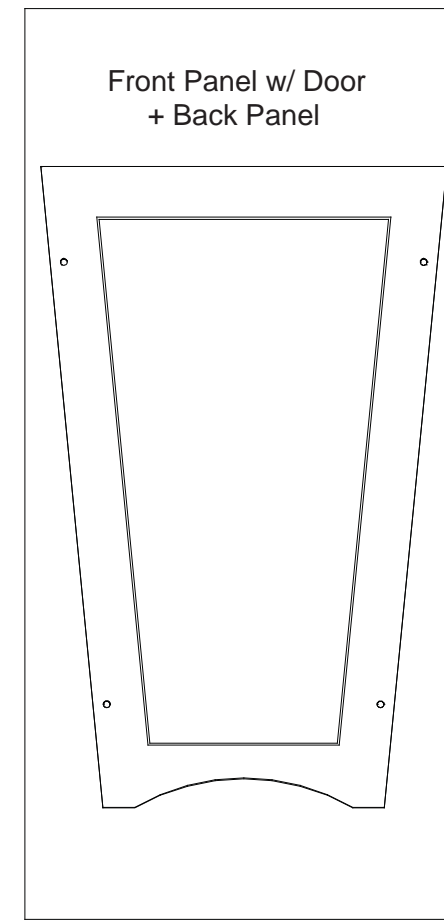

Level 4

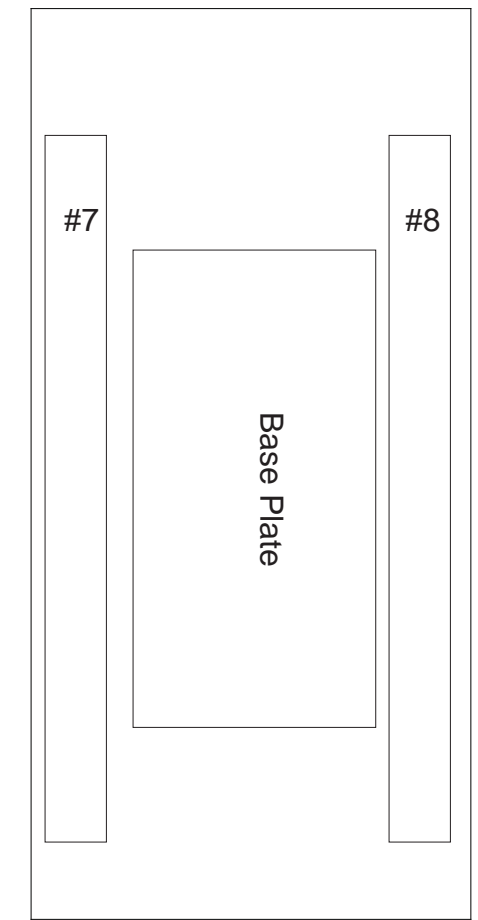

WHEN DISASSEMBLING ALUMINUM EXTRUSION, TIGHTEN ALL SETSCREWS AND LOCKS TO PREVENT LOSS DURING SHIPPING

Top View of each Level

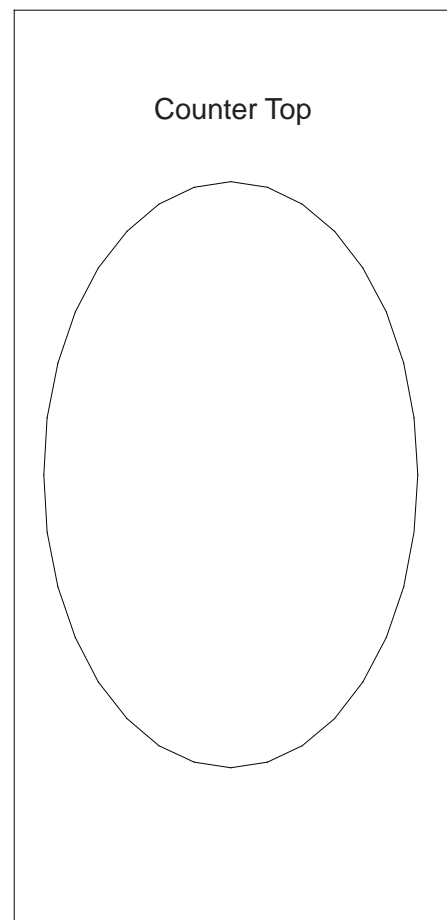

Level 1

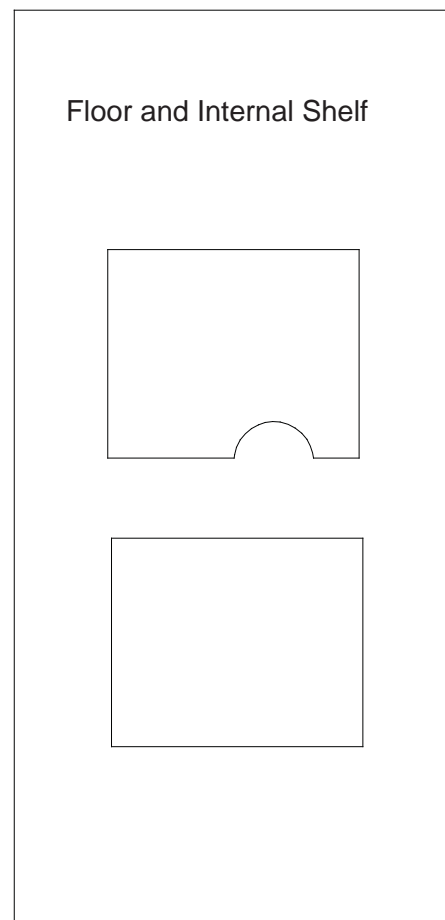

Level 2

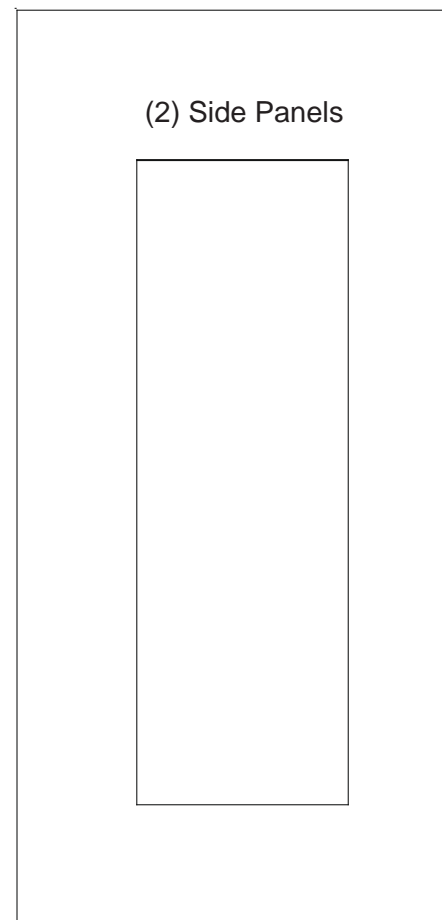

Level 3

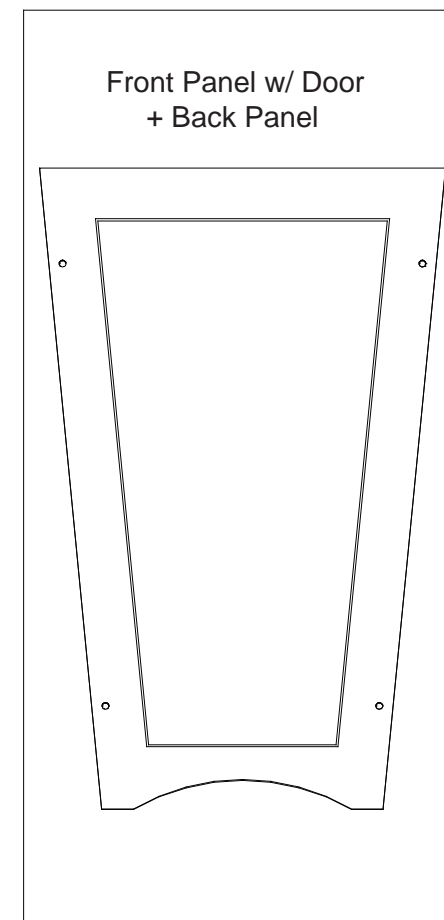

Level 4

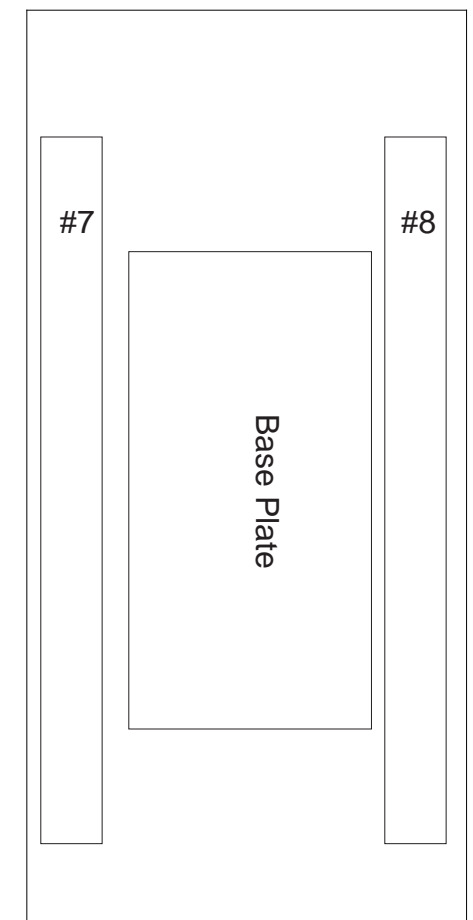

WHEN DISASSEMBLING ALUMINUM EXTRUSION, TIGHTEN ALL SETSCREWS AND LOCKS TO PREVENT LOSS DURING SHIPPING

Top View of each Level

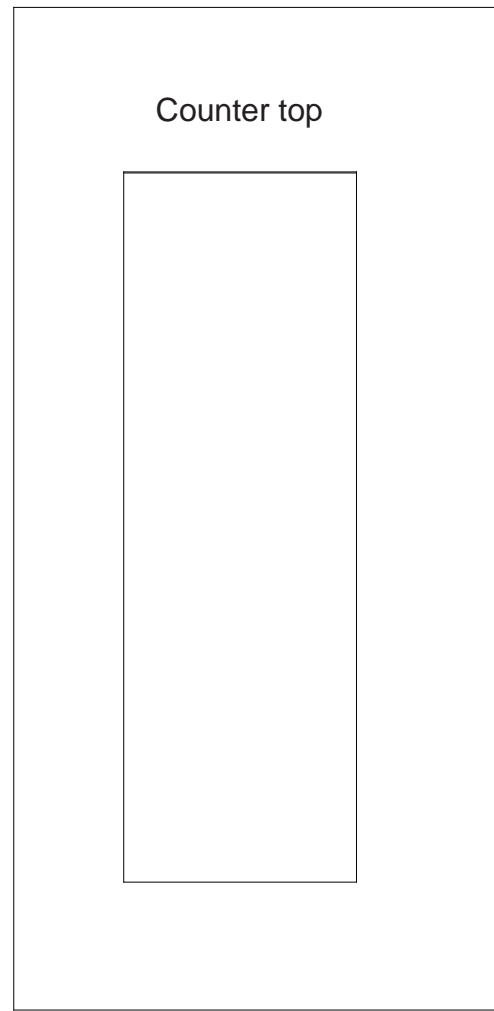

Level 1

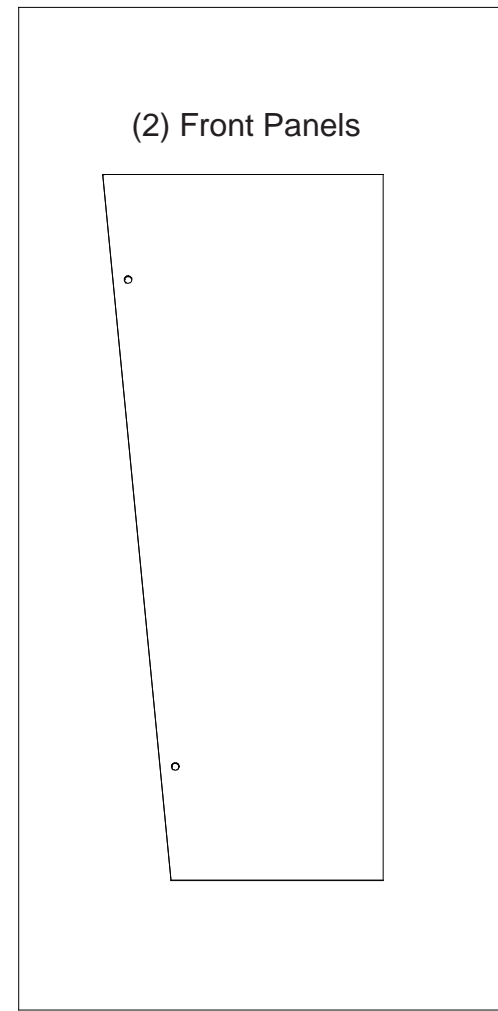

Level 2

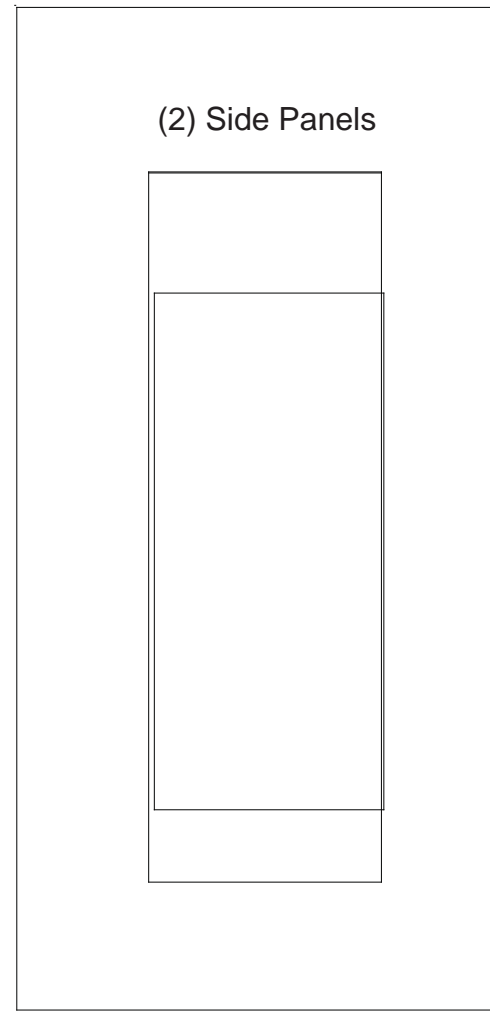

Level 3

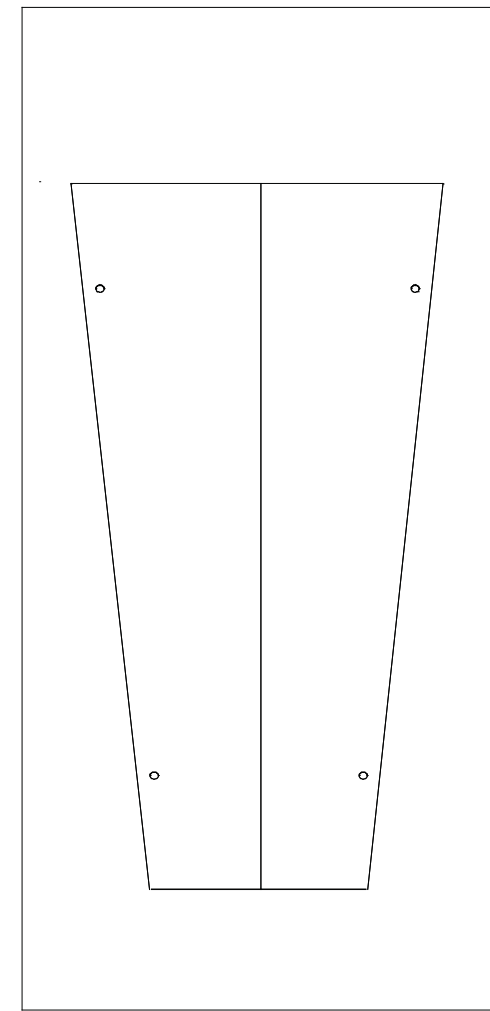

Level 4

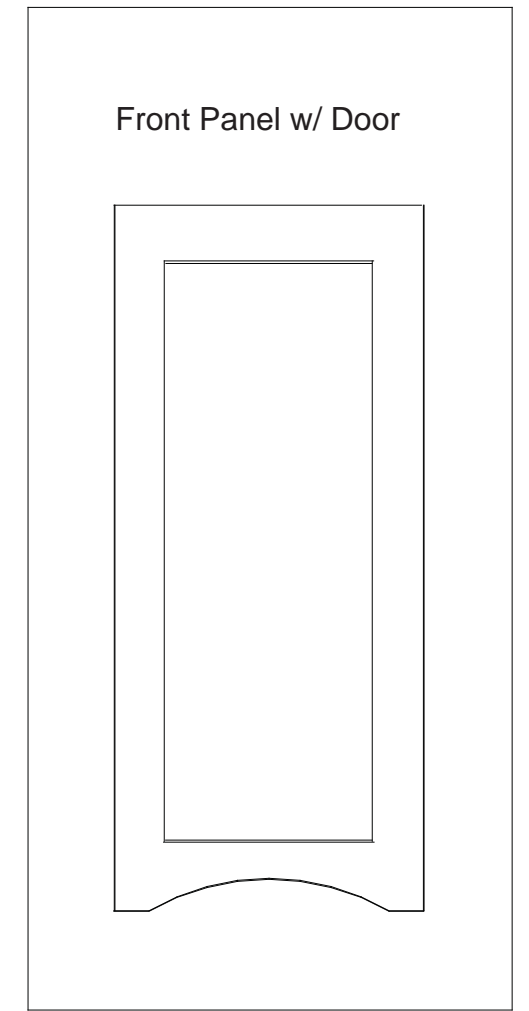

Level 5

WHEN DISASSEMBLING ALUMINUM EXTRUSION, TIGHTEN ALL SETSCREWS AND LOCKS TO PREVENT LOSS DURING SHIPPING

Top View of each Level

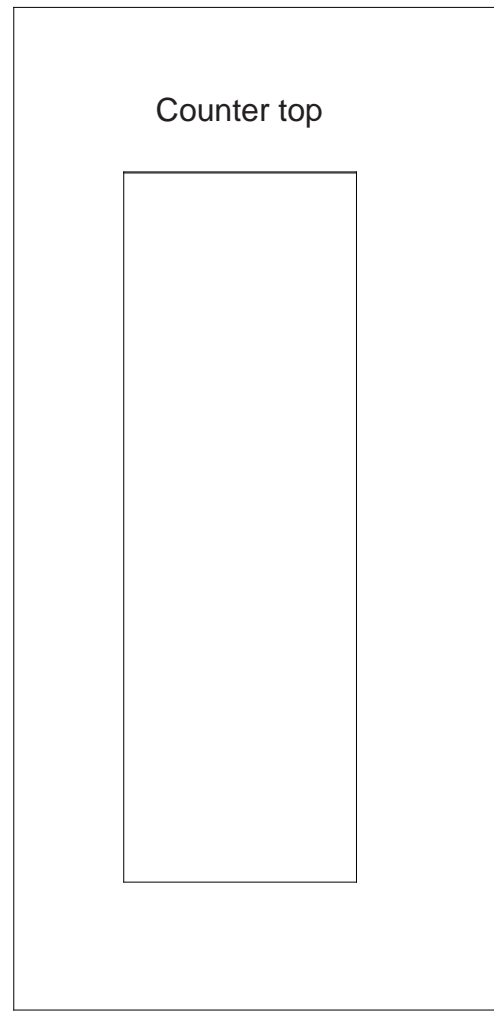

Level 1

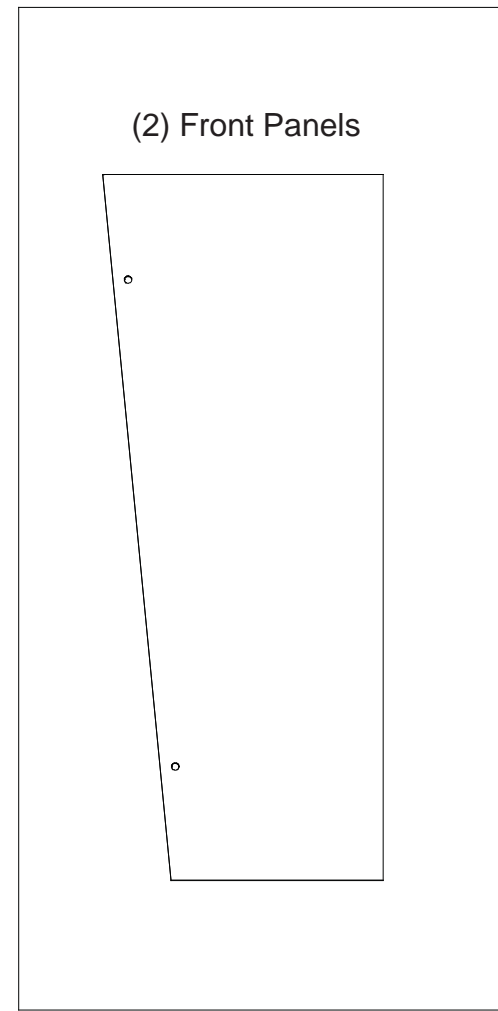

Level 2

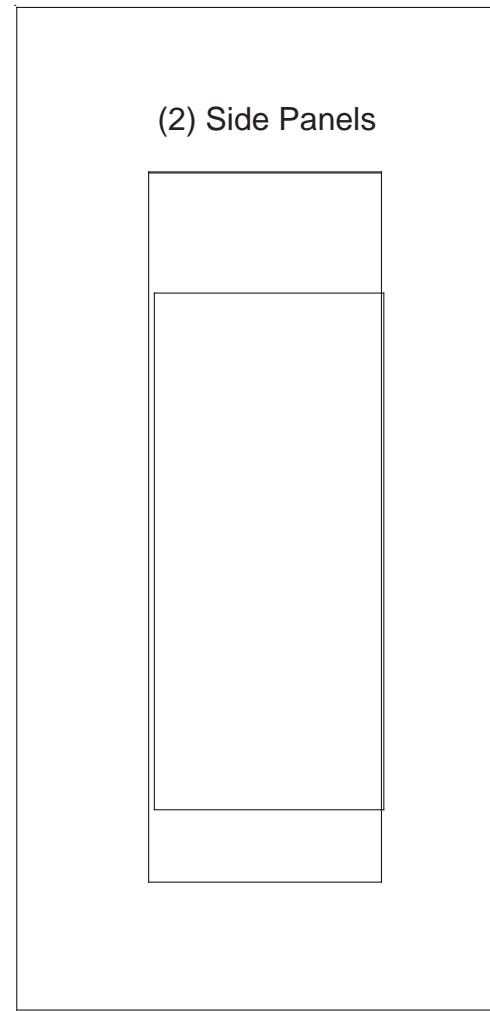

Level 3

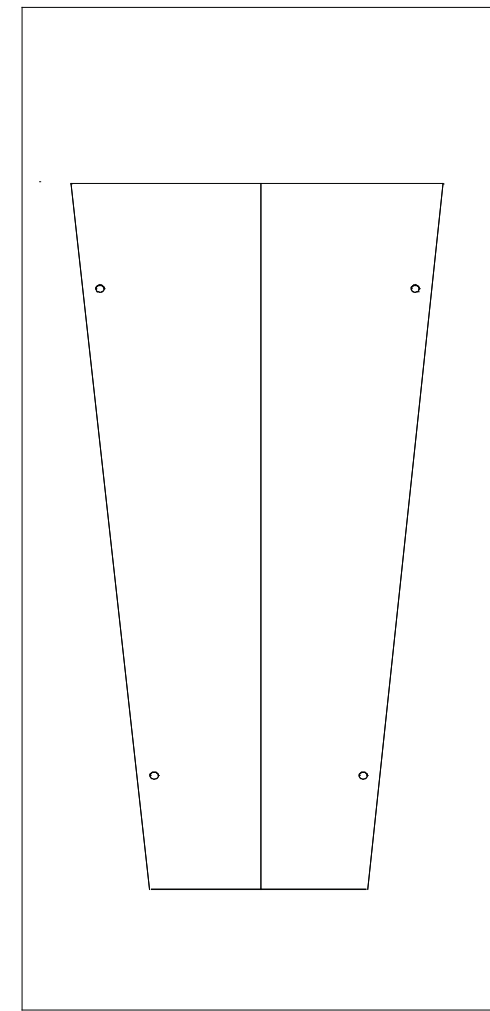

Level 4

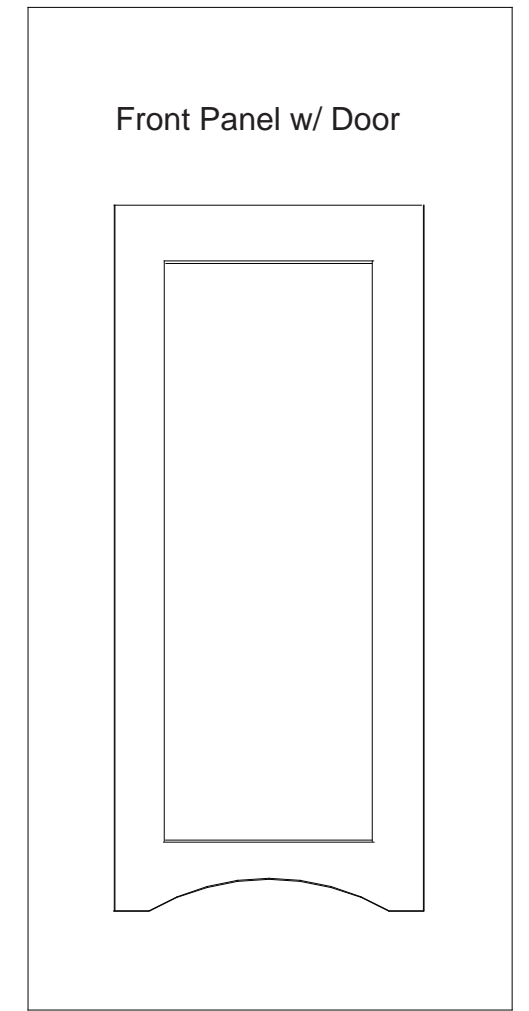

Level 5

WHEN DISASSEMBLING ALUMINUM EXTRUSION, TIGHTEN ALL SETSCREWS AND LOCKS TO PREVENT LOSS DURING SHIPPING