

WHEN DISASSEMBLING ALUMINUM EXTRUSION, TIGHTEN ALL SETSCREWS AND LOCKS TO PREVENT LOSS DURING SHIPPING

visionary™ DESIGNS

Using Your Setup Instructions

The Visionary Designs Setup Instructions are created specifically for your configuration. They are laid out sequentially, including an exploded view of the entire display, and then a logical series of detailed steps to assemble the main structure and components. We encourage you to study the instructions **before** attempting to assemble your exhibit.

Each page reminds you to tighten the setscrews after disassembling your exhibit to prevent loss of the locks and setscrews (see below in RED). This is **VERY IMPORTANT**.

Cleaning and Packing Your Display

- 1) Use care when cleaning aluminum extrusion or acrylic inserts. Use only non-abrasive cleaners.
- 2) When cleaning laminate inserts or countertops, use mild cleansers and a soft material such as cotton.
- 3) Keep all display components away from extreme heat and long exposure to sunlight to avoid warping and fading.
- 4) Retain all packing material. It will make re-packing much easier and will reduce the likelihood of shipping damage.



The Tool

Most Visionary Designs exhibits can be assembled with the supplied Hex Key Tool. Occasionally, a flat head screwdriver may be required.



Typical Connection



Typical Connection (cont'd)

Most horizontal extrusion connections have a patented expandable lock. This lock inserts into the groove of an opposing extrusion. Tightening the lock with the Hex Key Tool expands the lock and creates a strong positive connection.

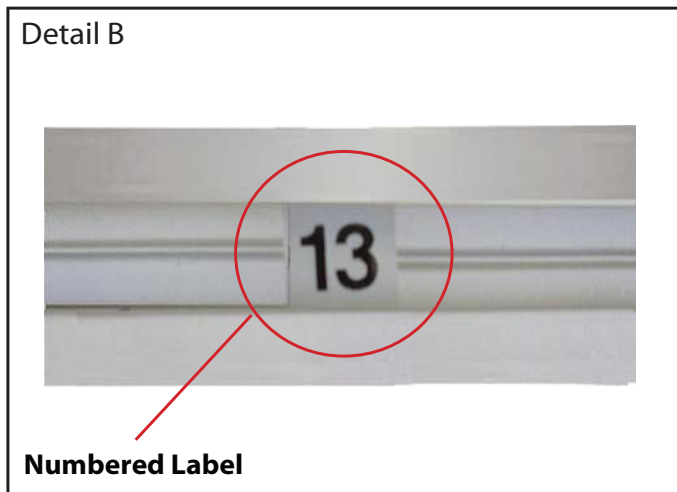

Detail B

Numbered Label

Each extrusion contains a numbered label which corresponds with setup instructions. The label is located within a groove of the extrusion (when possible). With Visionary Designs the labels contain Black numbers unless otherwise specified.



Detail C

Horizontal Inline Connection (remove only one setscrew)

Remove only (1) setscrew when disassembling. Replace setscrew in extrusion after assembling it. Before packing, replace setscrew in extrusion to avoid losing it.

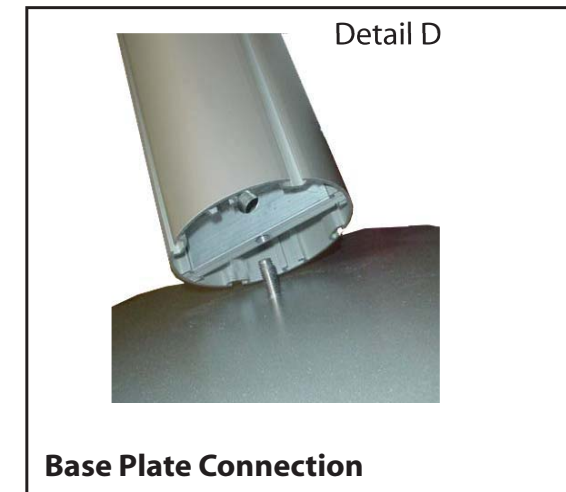

Detail D

Base Plate Connection

Attach base plate to round or square vertical extrusion using the bolt provided. Be careful not to strip the threads.

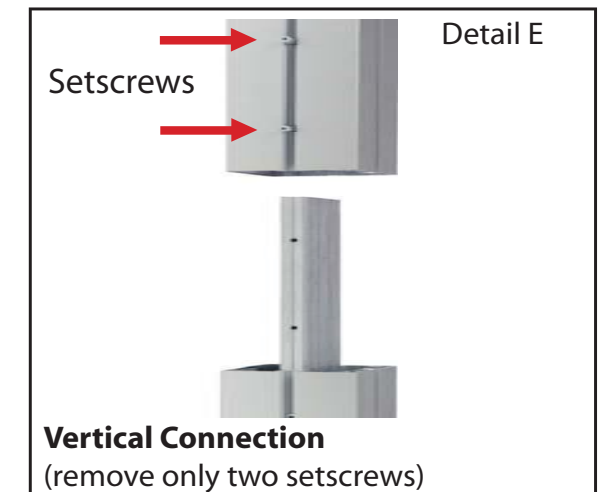

Detail E

Vertical Connection
(remove only two setscrews)

When vertical extrusions are packed in portable cases rather than crates or tubs, they must be broken down into smaller sections which then require assembly.

Remove only (2) setscrews when disassembling. Replace setscrews in extrusion after assembling it. Before packing, replace setscrews in extrusion to avoid losing them.



WHEN DISASSEMBLING ALUMINUM EXTRUSION, TIGHTEN ALL SETSCREWS AND LOCKS TO PREVENT LOSS DURING SHIPPING

Part Number	Qty	Description	Part Number	Qty	Description	Part Number	Qty	Description
1	2	Base Plate w/ slot	10	1	Base Plate w/ slot	22/23	1/1	Base Plate w/ slot
2	1	Base Plate w/ center hole	11	1	Base Plate w/ center hole	24/25/25a	1/1/1	Base Plate w/ center hole
3	1	Base Plate w/ center hole	12	1	Base Plate w/ center hole	26/27/27a	1/1/1	Base Plate w/ center hole
4	1	48.115" Lower Curved Extrusion	13	1	48.115" Lower Curved Extrusion			
5	1	48.115" Upper Curved Extrusion	14/15/15a	1/1/1	48.115" Upper Curved Extrusion			
6	1	47" Vertical Extrusion	16/17/17a	1/1/1	47" Vertical Extrusion			
7	1	47" Vertical Extrusion	18	2	47" Vertical Extrusion			
8	1	47" Vertical Extrusion	19	1	47" Vertical Extrusion			
9	1	47" Vertical Extrusion	20/21	1/1	47" Vertical Extrusion			

Steps:

- 1) Attach vertical extrusions to base plates [4 to 1, 6 to 2, 8 to 2, 10 to 2, and 12 to 3].
- 2) Connect vertical pieces together [4 to 5, 6 to 7, 8 to 9, 10 to 11, and 12 to 13].
- 3) Connect curved horizontal extrusions together [14 to 15 to 15a, 16 to 17 to 17a, 24 to 25 to 25a, and 26 to 27 to 27a].
- 4) Connect horizontal extrusions together [20 to 21 and 22 to 23].
- 5) Attach horizontal assemblies between vertical assemblies as shown below.

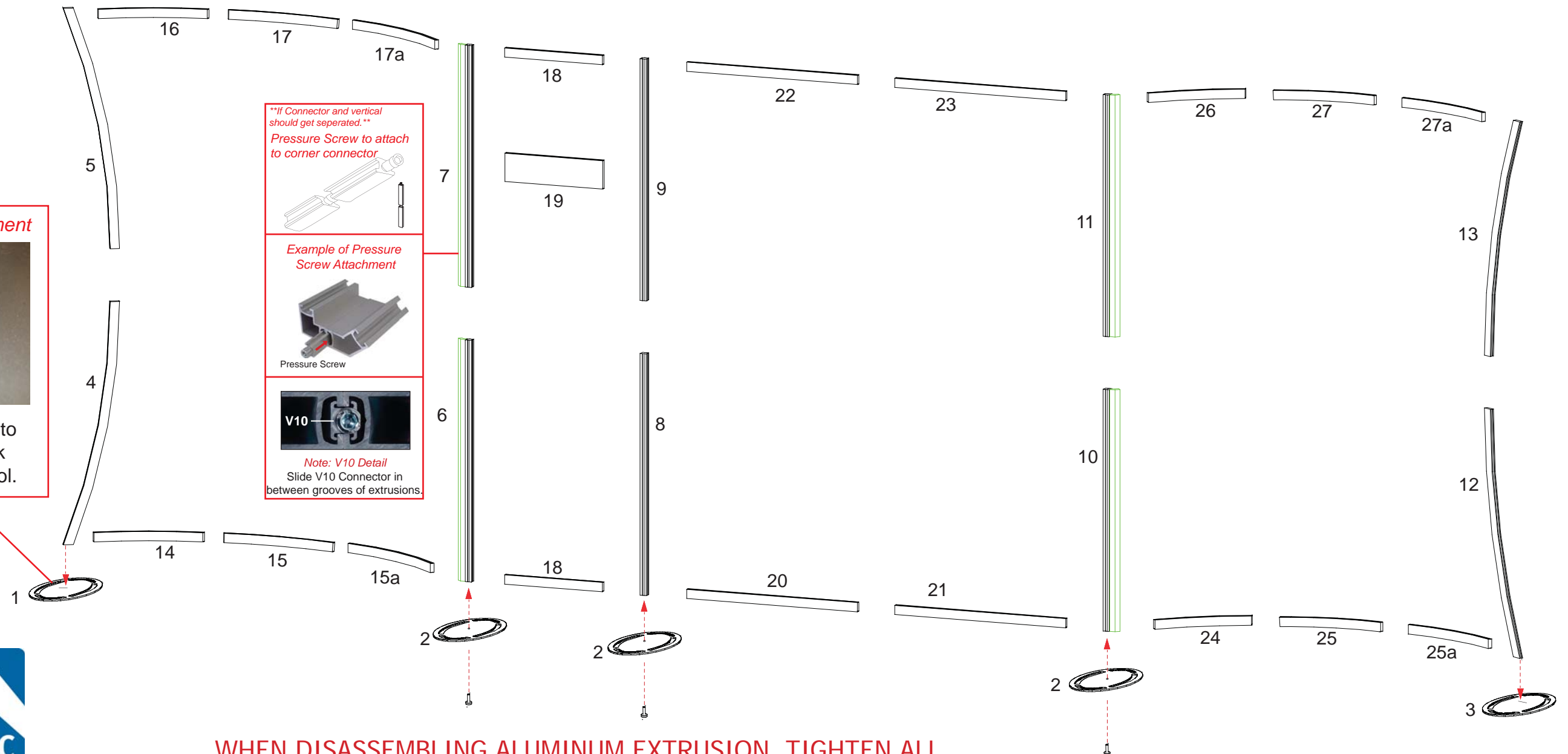

#1 and 3 Base Plate Attachment

Connect Vertical Extrusion to Base Plate by placing lock into slot and tighten with tool.

****If Connector and vertical should get seperated.****
 Pressure Screw to attach to corner connector

Example of Pressure Screw Attachment

Pressure Screw

Note: V10 Detail
 Slide V10 Connector in between grooves of extrusions.



WHEN DISASSEMBLING ALUMINUM EXTRUSION, TIGHTEN ALL SETSCREWS AND LOCKS TO PREVENT LOSS DURING SHIPPING

Item	Qty.	Description
28	2	Support Leg Assembly
28A	2	Lower Curved Support Leg

- Steps:
- 1) Attach assembled counter support [28] to vertical where indicated.
 - 2) Connect support leg [28A] to counter support assembly [28].
 - 3) Attach counter atop support, see counter top attachment detail.
 - 4) Attach monitor mount to assembled backwall, see attachment details below.
 - 5) Attach wings to A10 clamps.

Wing Attachment

Slide A10 Clamp into groove of square extrusion.



When desired location is found, tighten set screw to secure.



Tighten knob to secure Wing in place.



**Note: A10 clamps must stay attached with verticals*

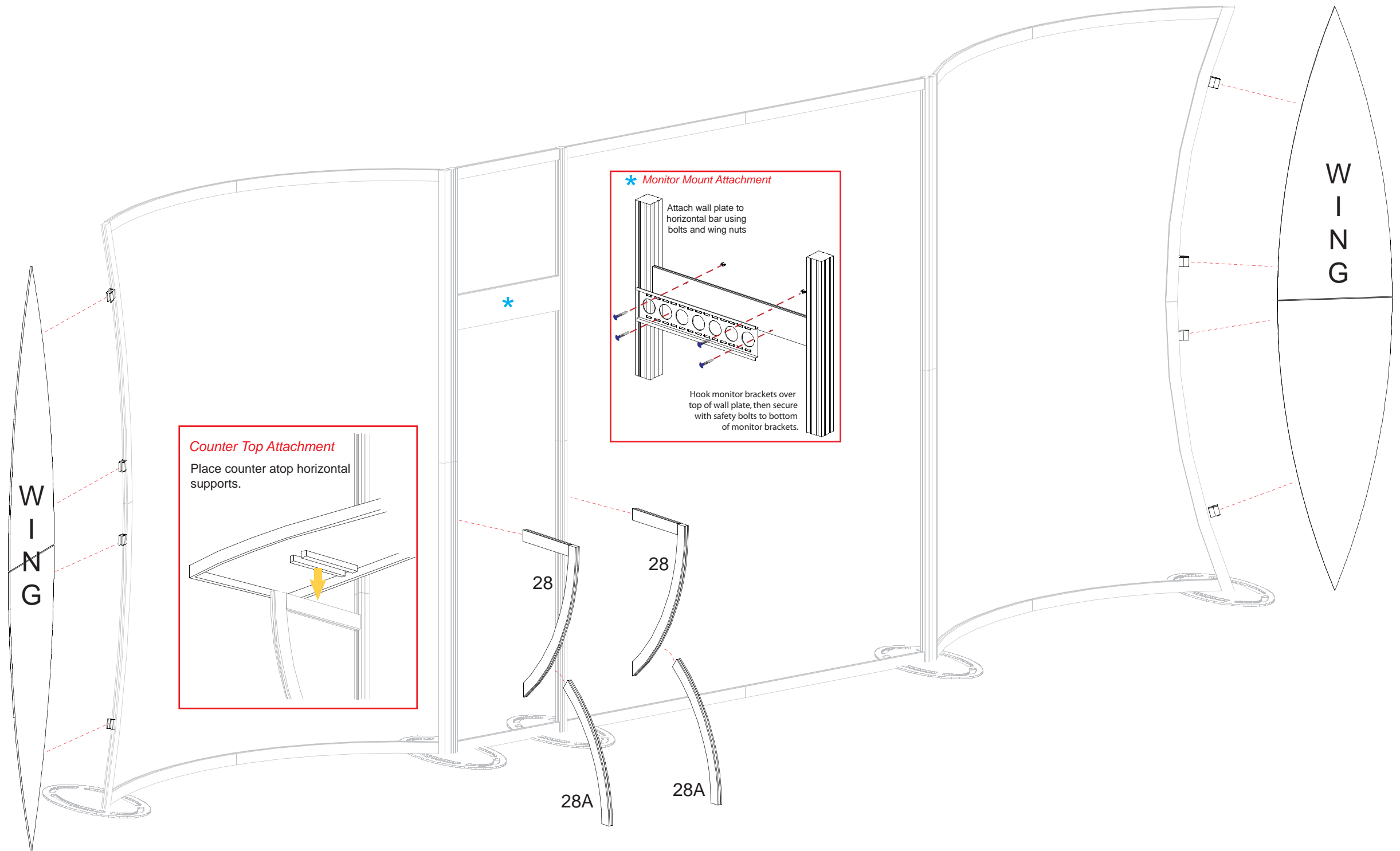

Counter Top Attachment

Place counter atop horizontal supports.



*** Monitor Mount Attachment**

Attach wall plate to horizontal bar using bolts and wing nuts

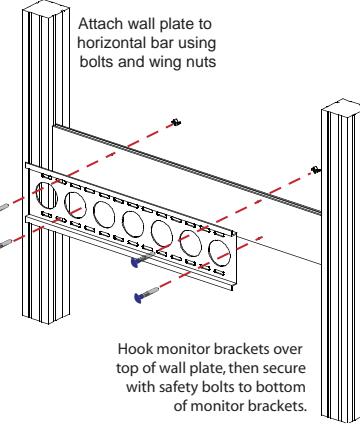

Hook monitor brackets over top of wall plate, then secure with safety bolts to bottom of monitor brackets.



WHEN DISASSEMBLING ALUMINUM EXTRUSION, TIGHTEN ALL SETSCREWS AND LOCKS TO PREVENT LOSS DURING SHIPPING

Part Number	Qty	Description
29	1	Round Base Plate
30	1	47" h Upper Vertical Extrusion
31	1	47" h Lower Vertical Extrusion
32	1	37.25" h Vertical Extrusion
32A	1	6" w Horizontal Extrusion
33	1	42" w Horizontal Extrusion

Steps:

- 1) Attach vertical extrusions [30 and 32] to base plate [29] as shown, see detail D on General Information Page.
- 2) Attach horizontal extrusion [32a] between verticals [30 and 32].
- 3) Slide counter top on vertical extrusion [30] and set atop vertical extrusion [32].
- 4) Connect upper vertical extrusion [31] atop lower extrusion [30].
- 5) Connect assembled workstation to backwall using horizontal extrusion [33] as shown.
- 6) Attach graphic sign to workstation vertical using stand-offs and screw caps.

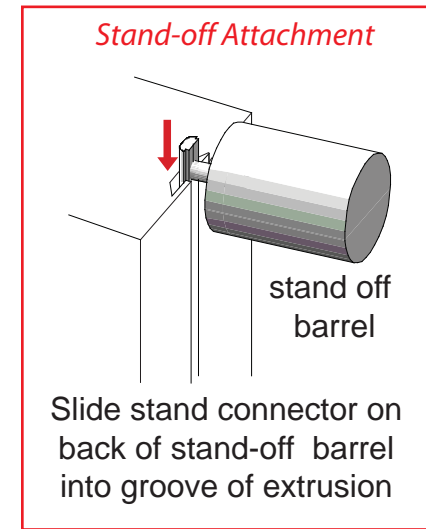
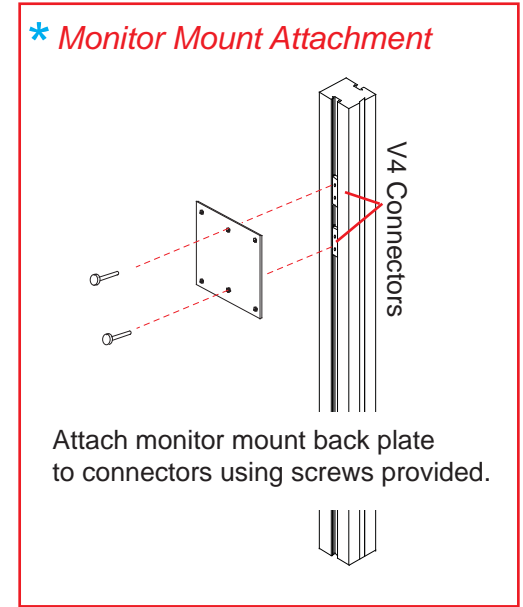
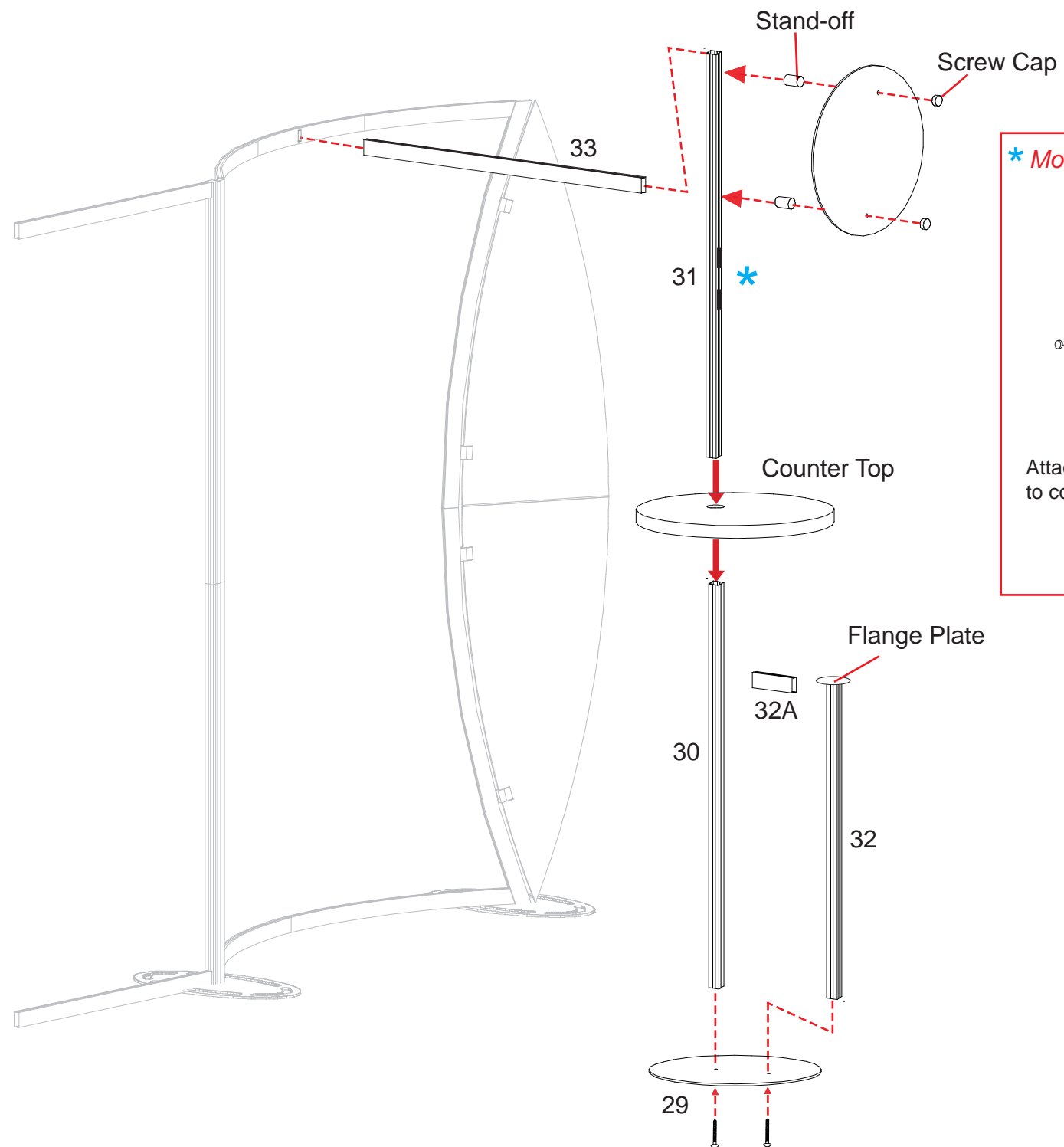

WHEN DISASSEMBLING ALUMINUM EXTRUSION, TIGHTEN ALL SETSCREWS AND LOCKS TO PREVENT LOSS DURING SHIPPING

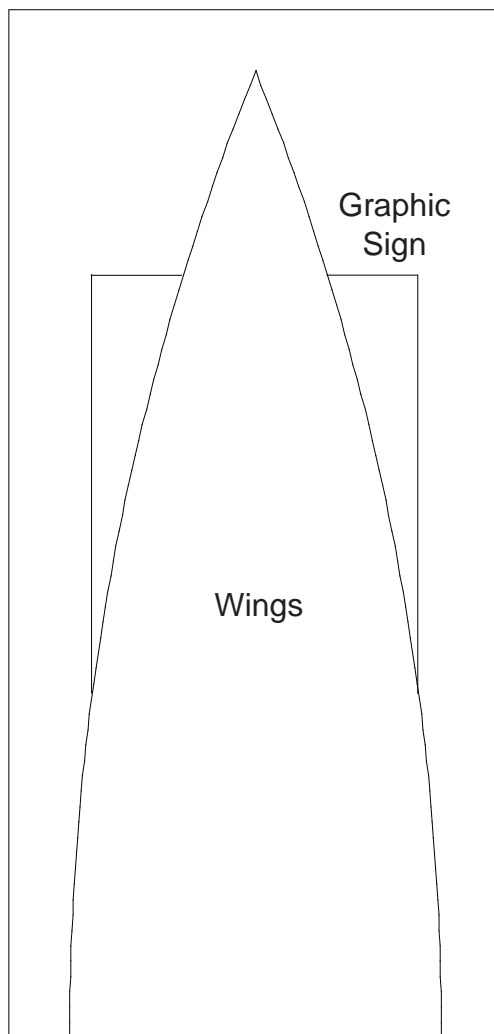

Level 1

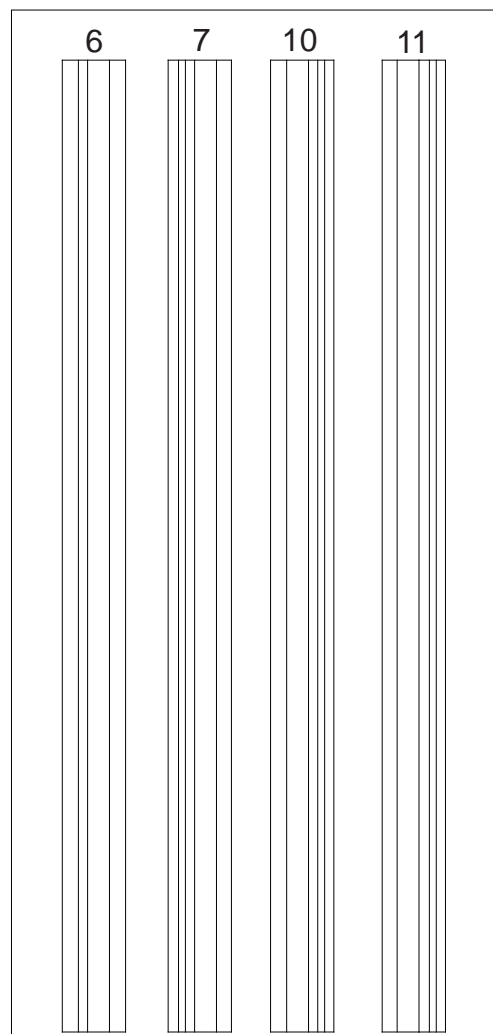

Level 2

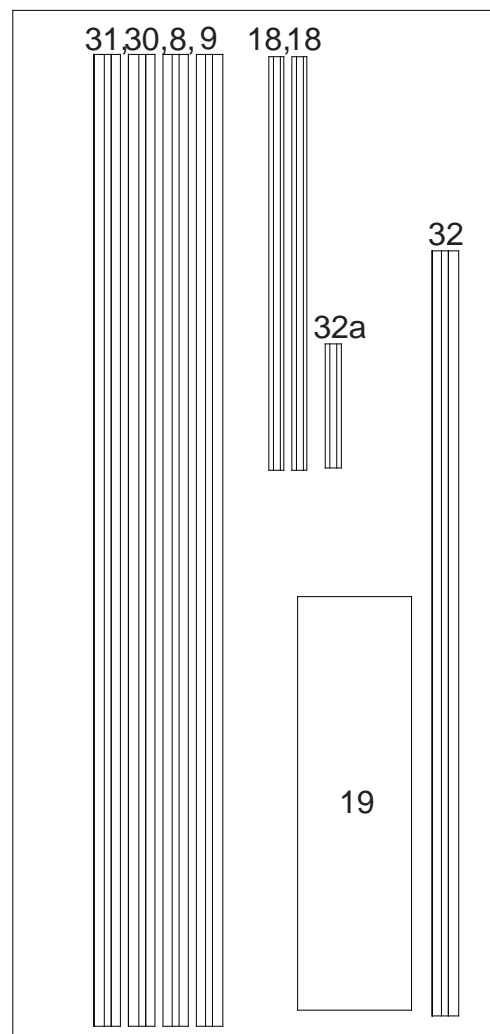

Level 3

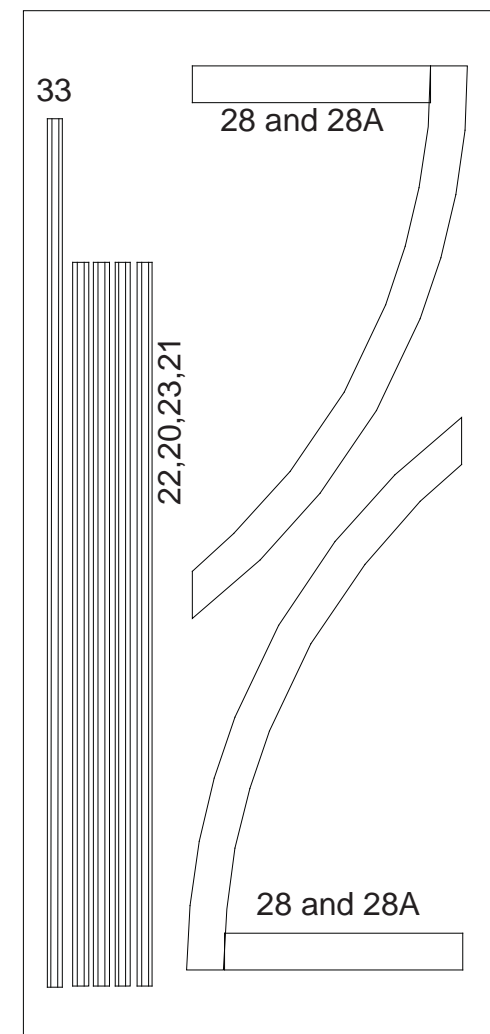

Level 4



WHEN DISASSEMBLING ALUMINUM EXTRUSION, TIGHTEN ALL SETSCREWS AND LOCKS TO PREVENT LOSS DURING SHIPPING

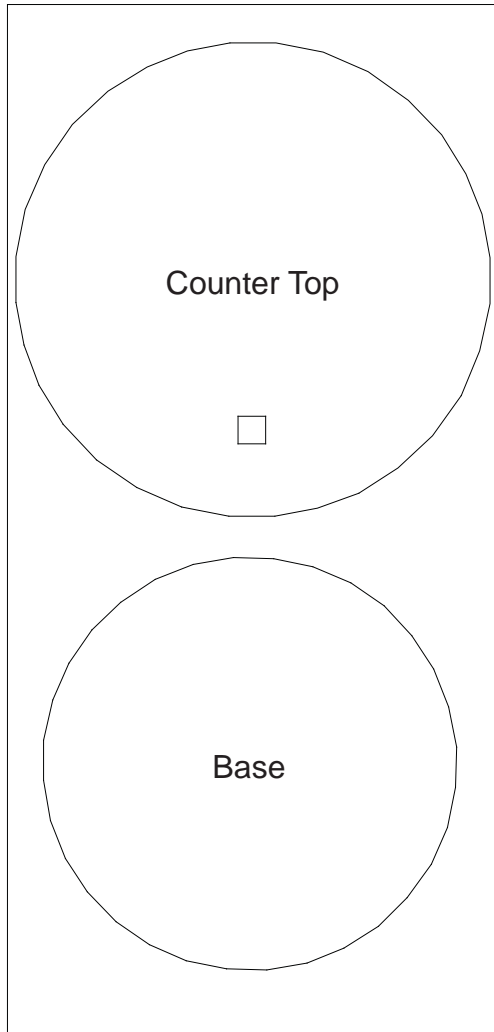

Level 1

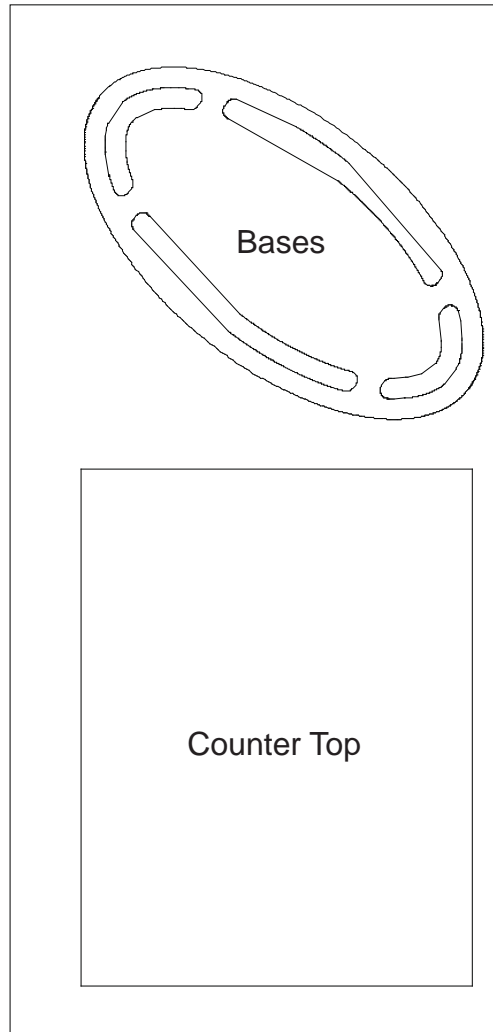

Level 2

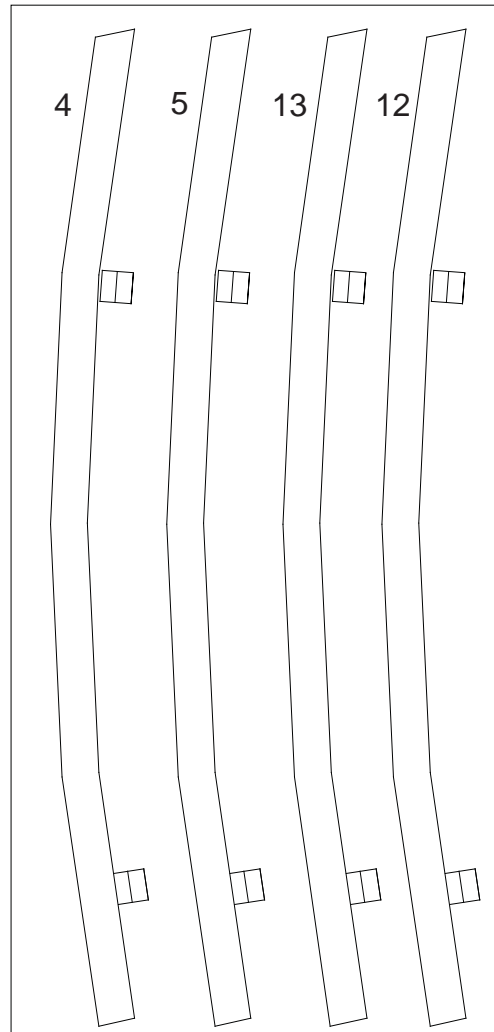

Level 3

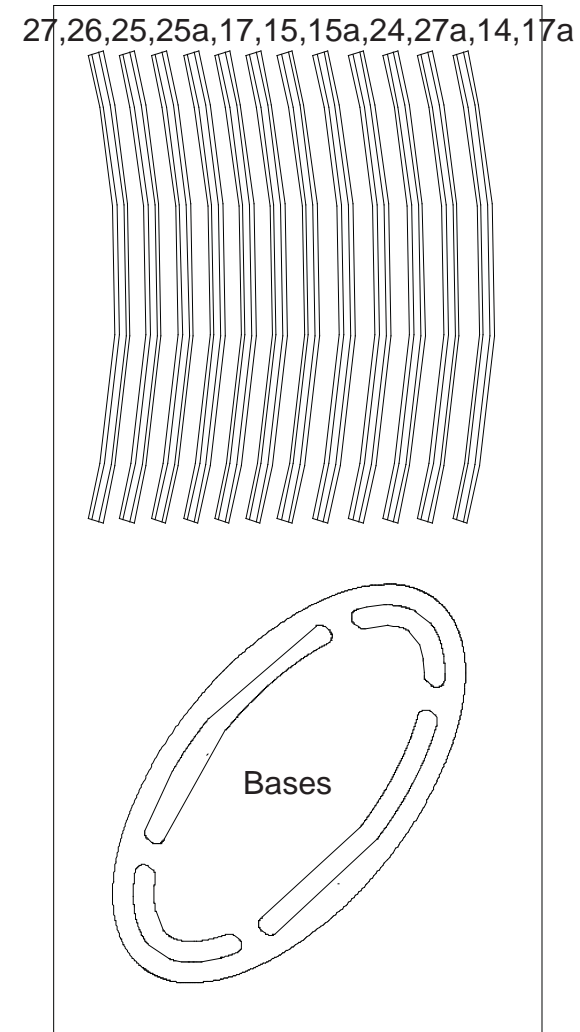

Level 4

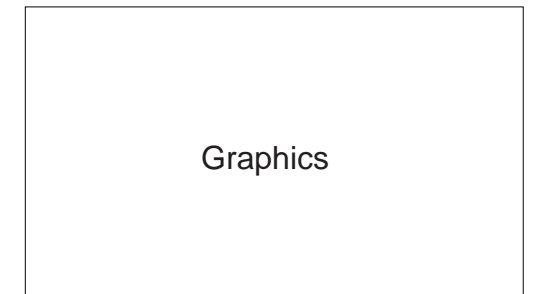

WHEN DISASSEMBLING ALUMINUM EXTRUSION, TIGHTEN ALL SETSCREWS AND LOCKS TO PREVENT LOSS DURING SHIPPING