

WHEN DISASSEMBLING ALUMINUM EXTRUSION, TIGHTEN ALL SETSCREWS AND LOCKS TO PREVENT LOSS DURING SHIPPING

visionary™ DESIGNS

Using Your Setup Instructions

The Visionary Designs Setup Instructions are created specifically for your configuration. They are laid out sequentially, including an exploded view of the entire display, and then a logical series of detailed steps to assemble the main structure and components. We encourage you to study the instructions **before** attempting to assemble your exhibit.

Each page reminds you to tighten the setscrews after disassembling your exhibit to prevent loss of the locks and setscrews (see below in RED). This is **VERY IMPORTANT**.

Cleaning and Packing Your Display

- 1) Use care when cleaning aluminum extrusion or acrylic inserts. Use only non-abrasive cleaners.
- 2) When cleaning laminate inserts or countertops, use mild cleansers and a soft material such as cotton.
- 3) Keep all display components away from extreme heat and long exposure to sunlight to avoid warping and fading.
- 4) Retain all packing material. It will make re-packing much easier and will reduce the likelihood of shipping damage.



The Tool

Most Visionary Designs exhibits can be assembled with the supplied Hex Key Tool. Occasionally, a flat head screwdriver may be required.



Typical Connection

Most horizontal extrusion connections have a patented expandable lock. This lock inserts into the groove of an opposing extrusion. Tightening the lock with the Hex Key Tool expands the lock and creates a strong positive connection.



Typical Connection (cont'd)



Detail B

Numbered Label

Each extrusion contains a numbered label which corresponds with setup instructions. The label is located within a groove of the extrusion (when possible). With Visionary Designs the labels contain Black numbers unless otherwise specified.



Detail C

Horizontal Inline Connection (remove only one setscrew)

Remove only (1) setscrew when disassembling. Replace setscrew in extrusion after assembling it. Before packing, replace setscrew in extrusion to avoid losing it.

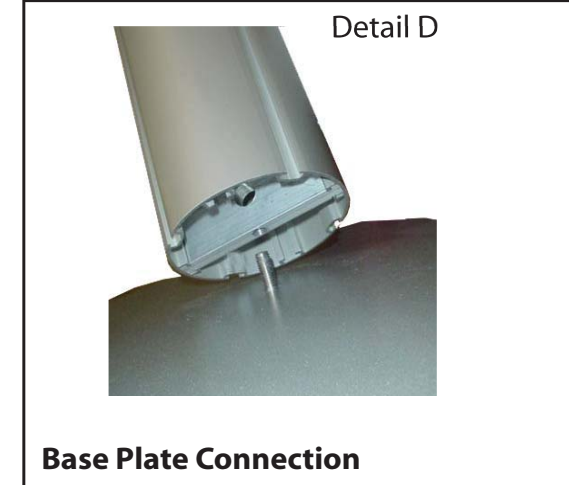

Detail D

Base Plate Connection

Attach base plate to round or square vertical extrusion using the bolt provided. Be careful not to strip the threads.

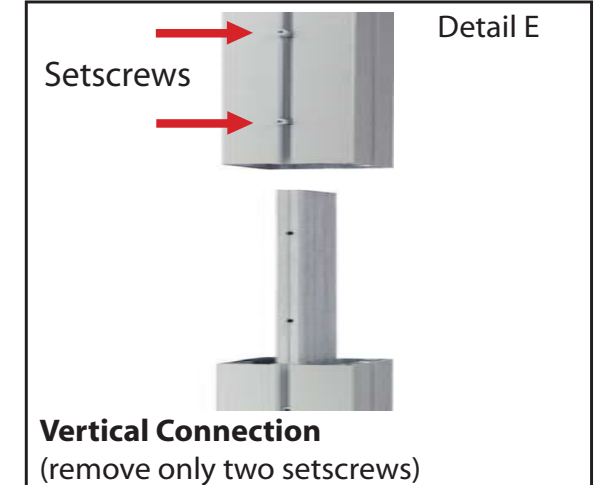

Detail E

Vertical Connection
(remove only two setscrews)

When vertical extrusions are packed in portable cases rather than crates or tubs, they must be broken down into smaller sections which then require assembly.

Remove only (2) setscrews when disassembling. Replace setscrews in extrusion after assembling it. Before packing, replace setscrews in extrusion to avoid losing them.

WHEN DISASSEMBLING ALUMINUM EXTRUSION, TIGHTEN ALL SETSCREWS AND LOCKS TO PREVENT LOSS DURING SHIPPING

866.652.2100

Item	Qty.	Description
1	3	Oval Base Plate
2	2	42" h Lower Square Vertical Extrusion
3	1	42" h Upper Square Vertical Extrusion w/ Canopy Attachment
4	1	42" h Upper Square Vertical Extrusion
5	1	42" h Lower Round Vertical Extrusion
6	1	42" h Upper Round Vertical Extrusion w/ Canopy Attachment
7	2	28" Horizontal Extrusion
9A/9B	1/1	26" Horizontal Extrusion
10A/10B	1/1	26" Horizontal Extrusion

Steps:

- 1) Attach lower vertical extrusions [5] to oval base plate [1].
- 2) Attach upper vertical extrusions [3, 4 and 6] atop lower vertical extrusions [2 and 5].
- 3) Connect horizontal extrusions [9A to 9B and 10A to 10B] together.
- 4) Attach horizontal extrusions [7, 9A/9B and 10A/10B] between vertical extrusions [2/3, 2/4 and 5/6] as shown.
- 5) Apply graphics to assembled backwall, see Attaching Graphic details.

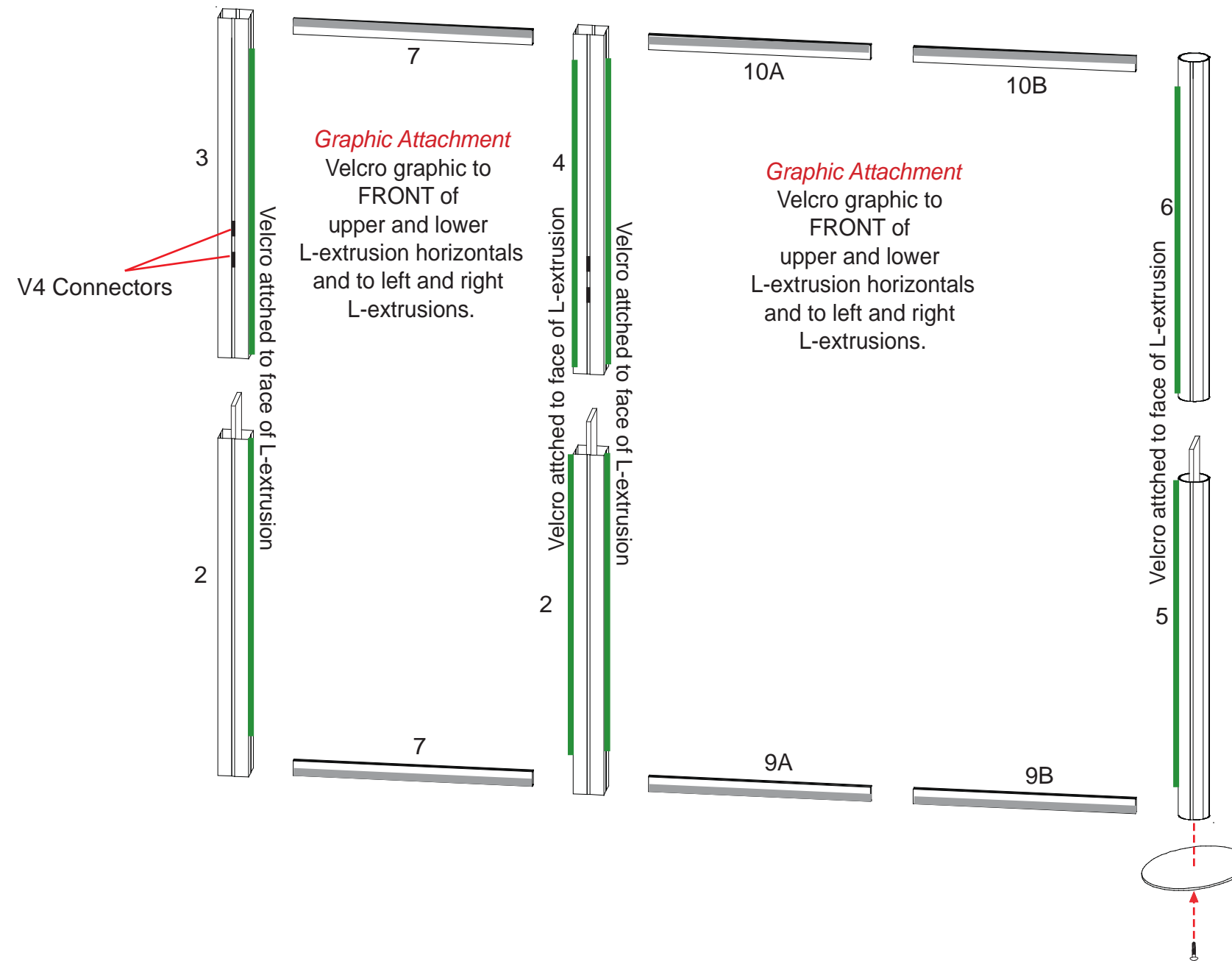
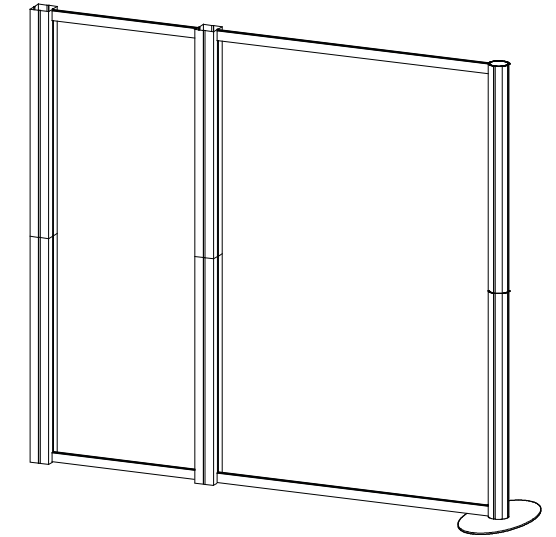

****L-Extrusions are highlighted in GREEN****
L-Extrusions must stay attached to extrusions when shipping.

WHEN DISASSEMBLING ALUMINUM EXTRUSION, TIGHTEN ALL SETSCREWS AND LOCKS TO PREVENT LOSS DURING SHIPPING

866.652.2100

Item	Qty	Description
11	2	38" h Round Vertical Extrusion
12	1	38" h 135° Corner Extrusion
13	1	38" h 135° Corner Extrusion w/ Door Hinges
14	4	12.5" w Horizontal Extrusion
15	2	Curved Horizontal Extrusion
16	1	34.418" h Vertical Extrusion w/ Door Stopper
4		Internal Shelf Support

Steps

- 1) Attach lower horizontal extrusions [12 and 13] between vertical extrusions as shown.
- 2) Attach vertical extrusion [16] to horizontal extrusion [15], leave loose, placing door and insert as shown, then tighten vertical extrusion [15] in place.
- 3) Place remaining inserts where indicated.
- 4) Attach upper horizontal extrusions [14 and 15] between vertical extrusions vertically as shown.
- 5) Velcro shelf support to inside of pedestal, then set internal shelf atop support.
- 6) Place counter atop assembled pedestal.

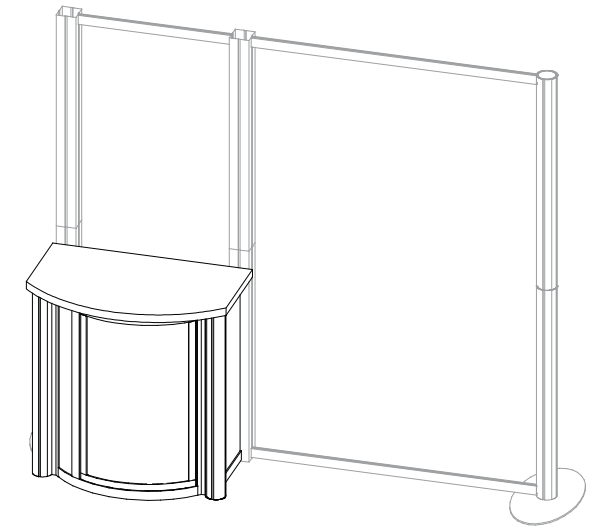

NOTE:

Extrusions 11/12 and 11/13 must stay assembled when shipping in cases.

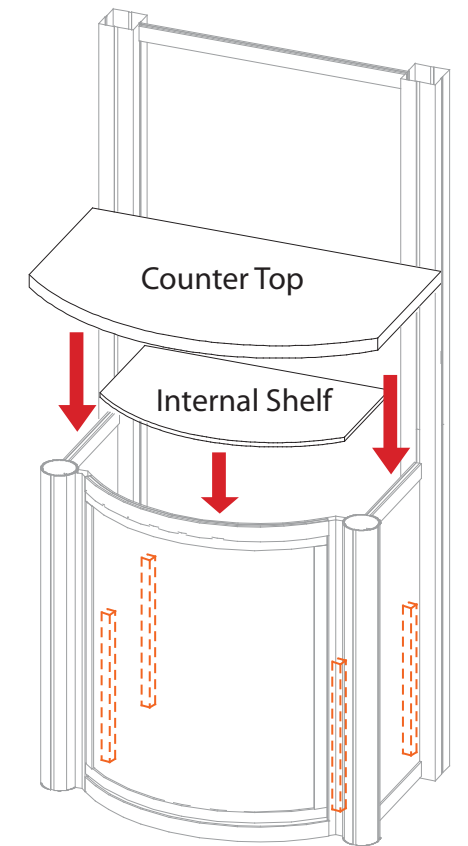
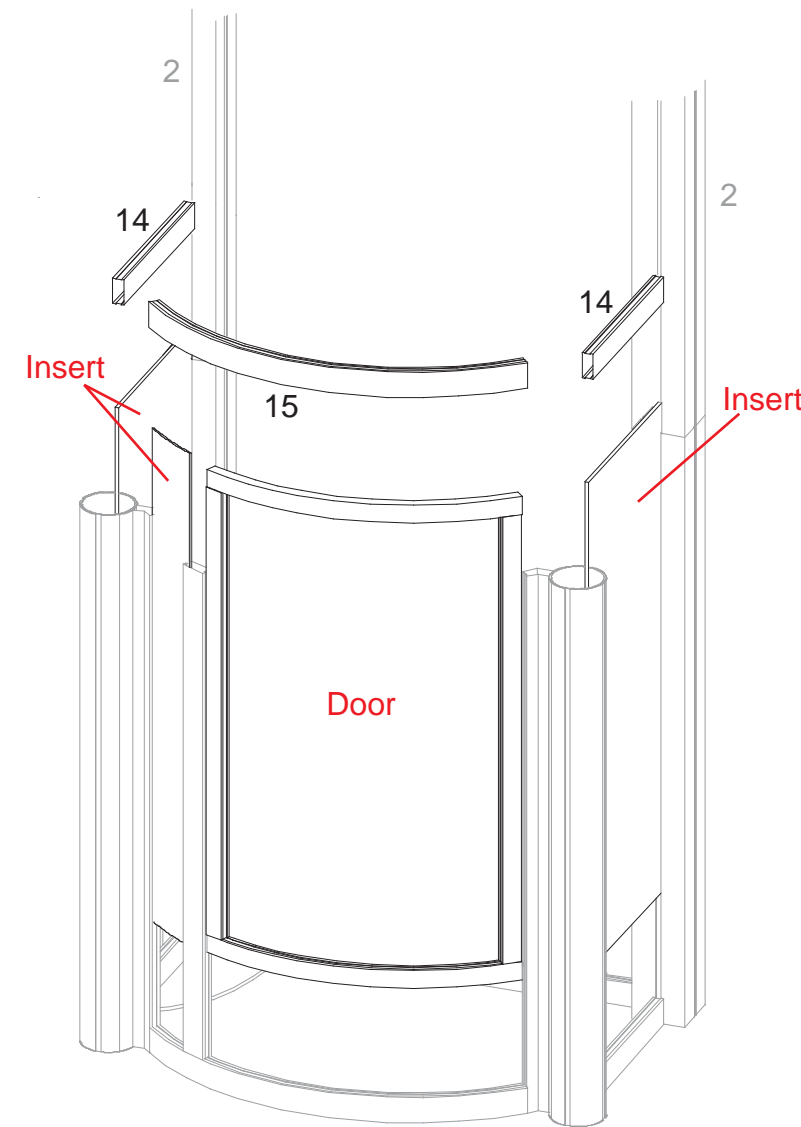
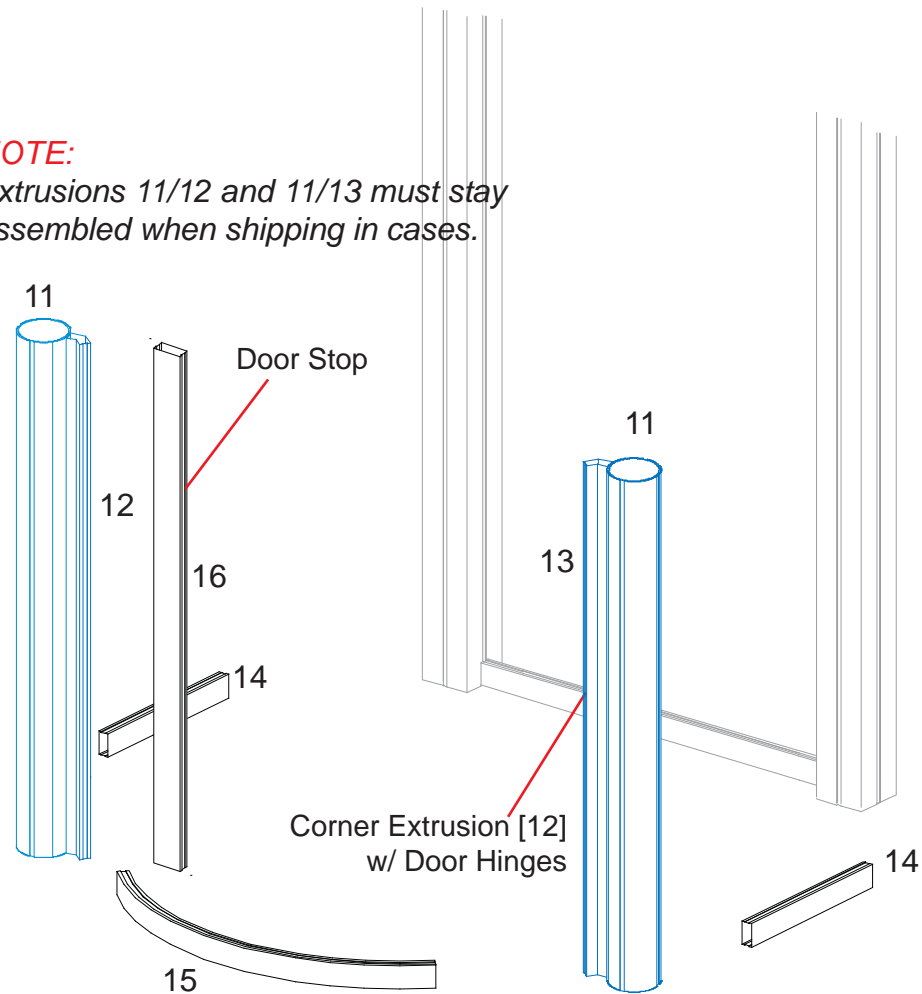

WHEN DISASSEMBLING ALUMINUM EXTRUSION, TIGHTEN ALL SETSCREWS AND LOCKS TO PREVENT LOSS DURING SHIPPING

866.652.2100

Item	Qty.	Description
17	1	5.862"w Vertical Extrusion
18	1	5.862"w Vertical Extrusion
19a/19b	1/1	40.319"w Formed Horizontal Extrusion
20a/20b	1/1	39"w Horizontal Extrusion

Steps

- 1) Connect vertical extrusions [17 and 18] to left and right side of horizontal extrusion [19a/19b].
- 2) Attach formed horizontal extrusion [20a/20b] atop vertical extrusions [17 and 18].
- 3) Attach header to assembled backwall as shown.
- 4) Attach wings using A10 clamps as shown.
- 5) Attach literature racks as shown

Example of Canopy Connection

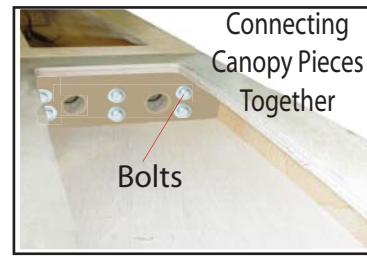

Connect 3 piece Canopy together by using bolts and wing nuts provided.

Note: Attaching Graphics
Attach Header Graphic to Back of assembled header frame.

Literature Rack Attachment

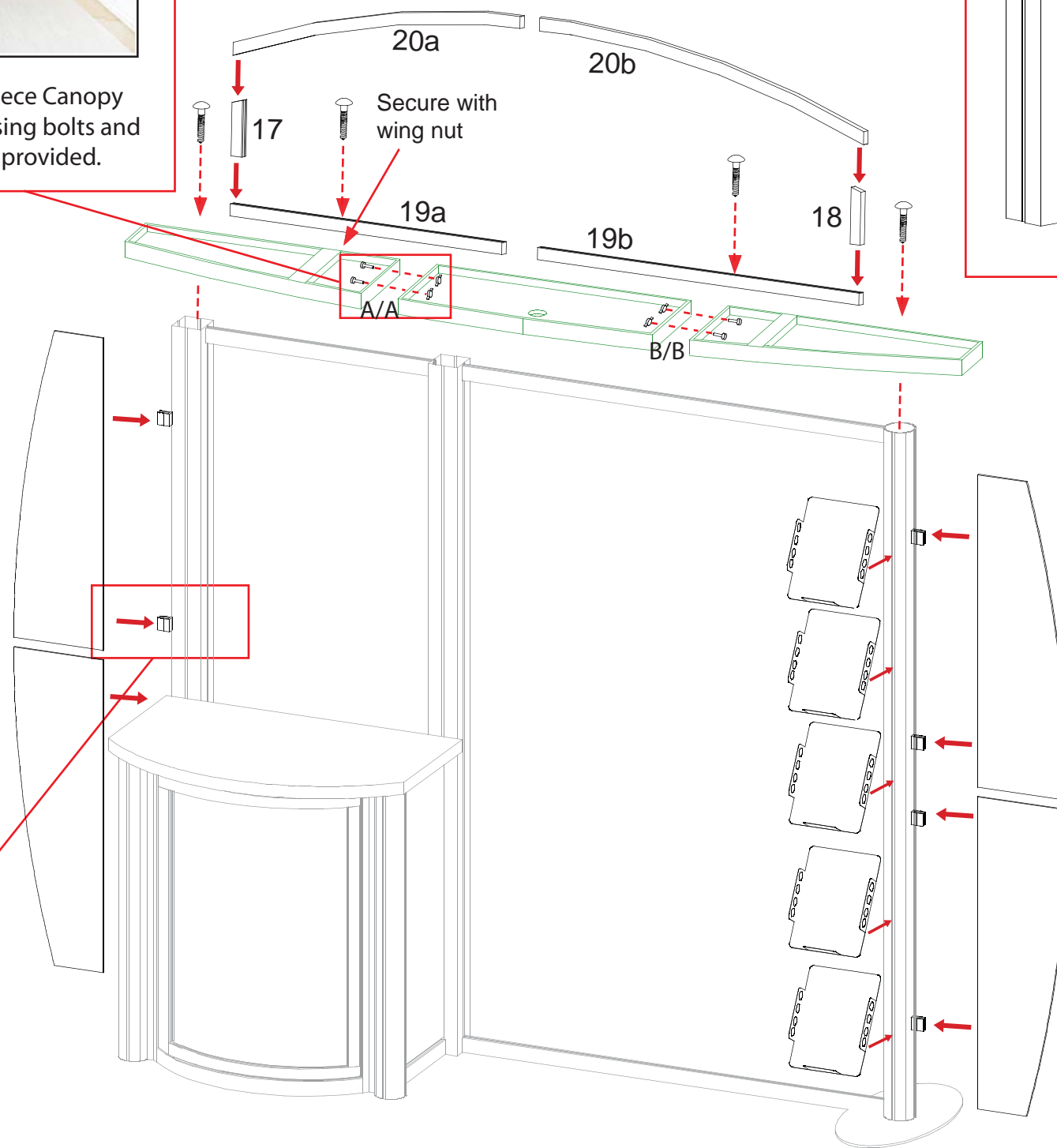
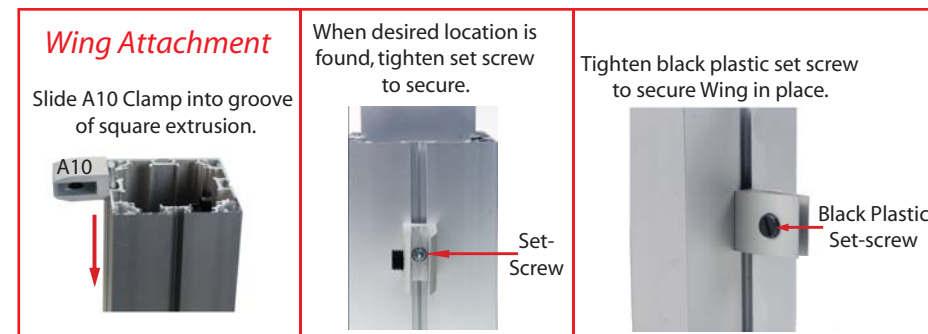
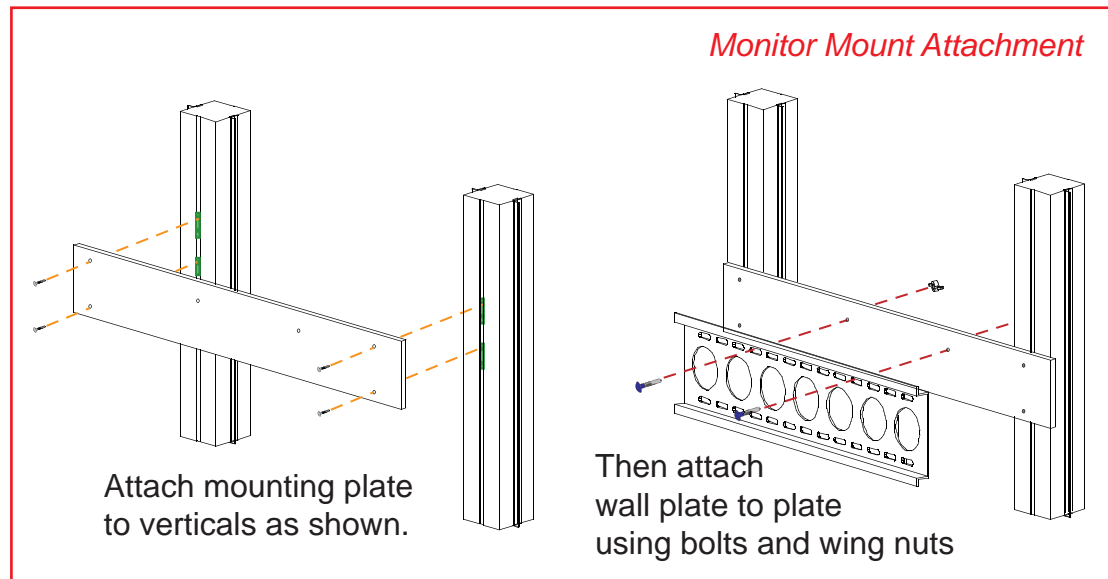
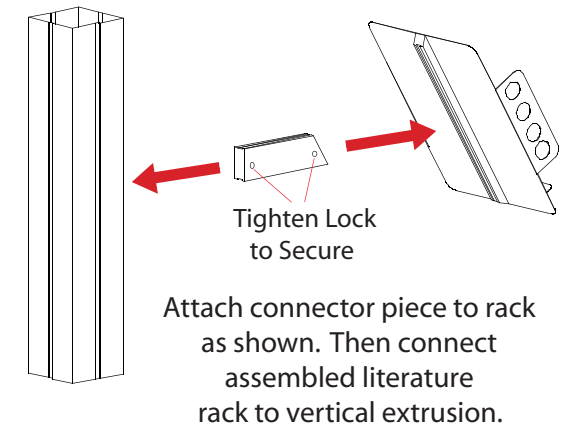

WHEN DISASSEMBLING ALUMINUM EXTRUSION, TIGHTEN ALL SETSCREWS AND LOCKS TO PREVENT LOSS DURING SHIPPING

Top View of each Level

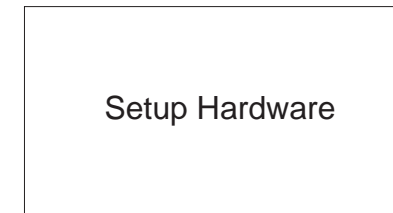
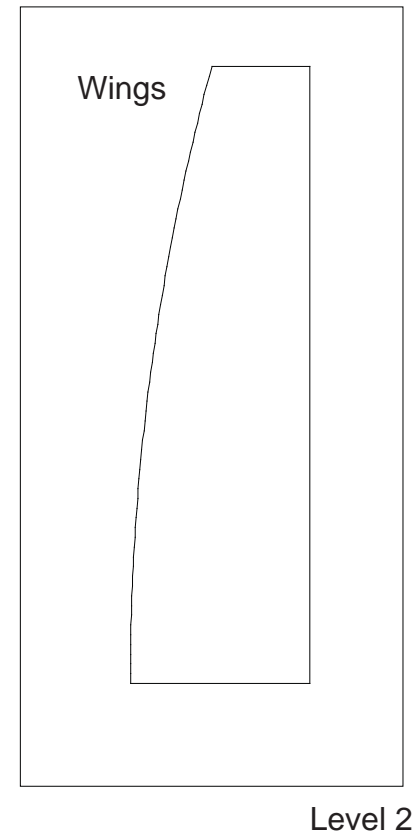
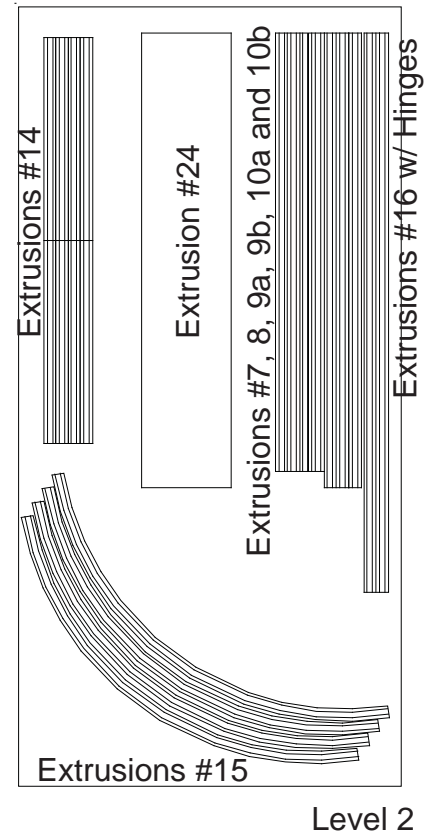
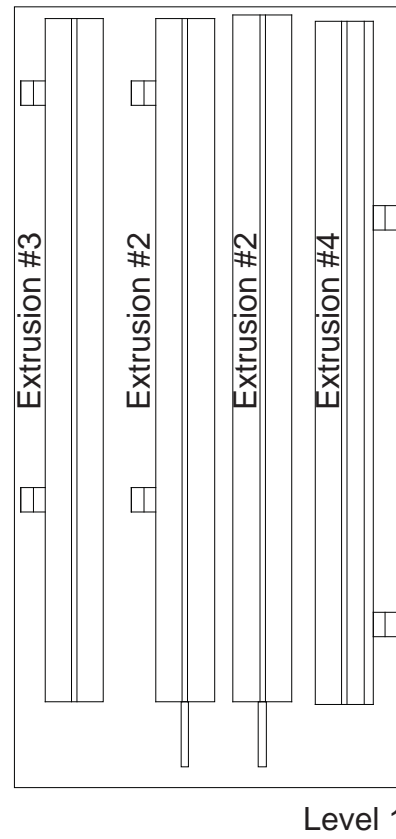

WHEN DISASSEMBLING ALUMINUM EXTRUSION, TIGHTEN ALL SETSCREWS AND LOCKS TO PREVENT LOSS DURING SHIPPING

Top View of each Level

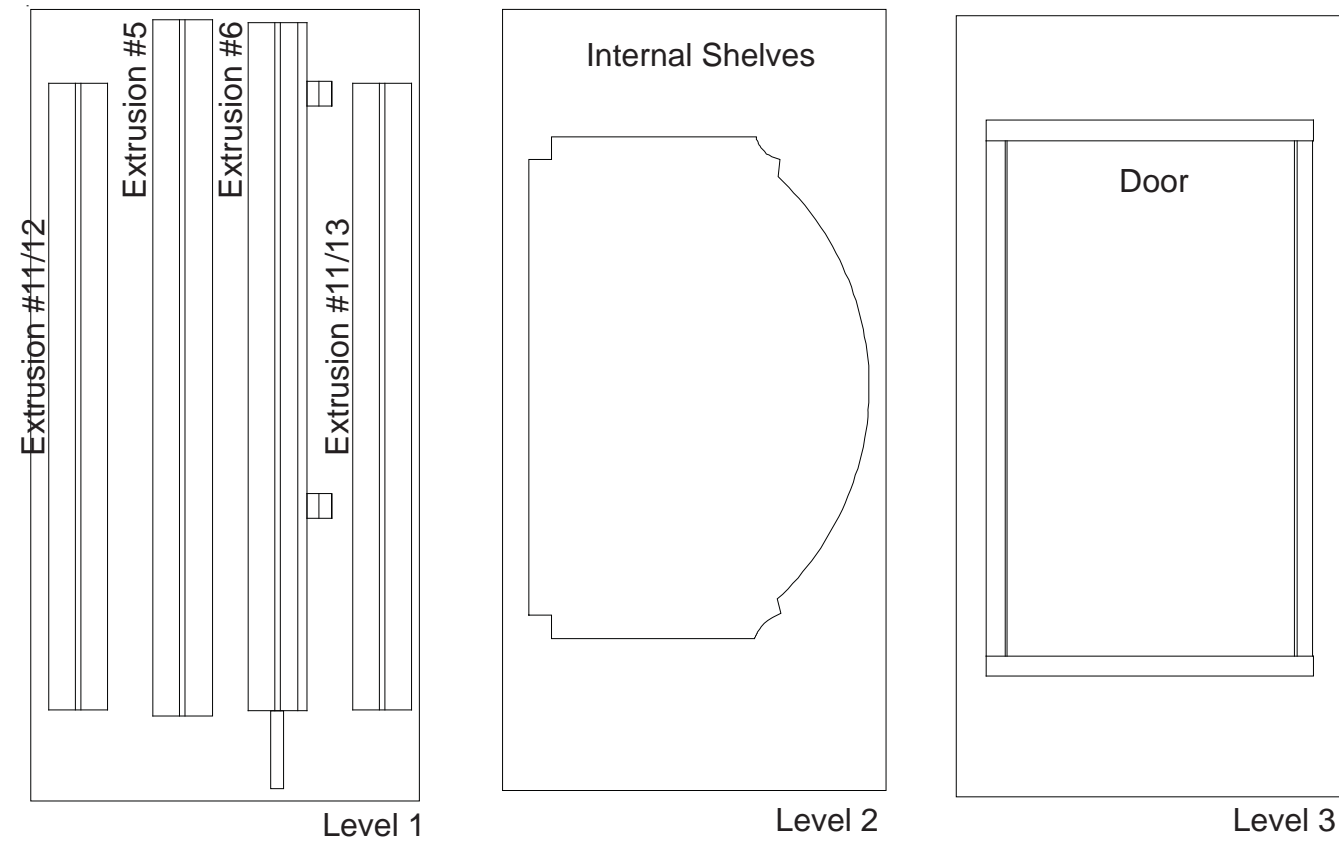

WHEN DISASSEMBLING ALUMINUM EXTRUSION, TIGHTEN ALL SETSCREWS AND LOCKS TO PREVENT LOSS DURING SHIPPING

Top View of each Level

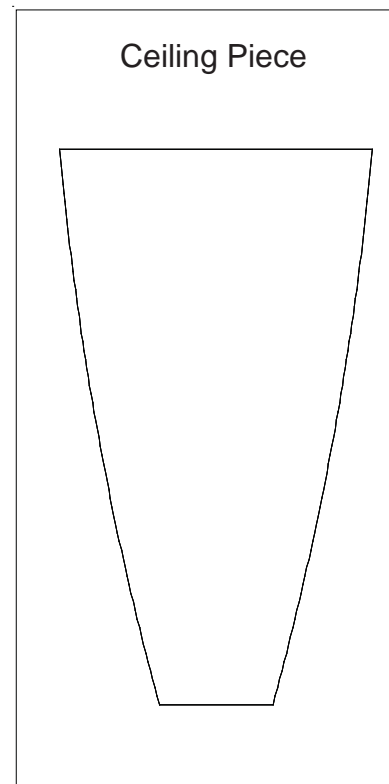

Level 1

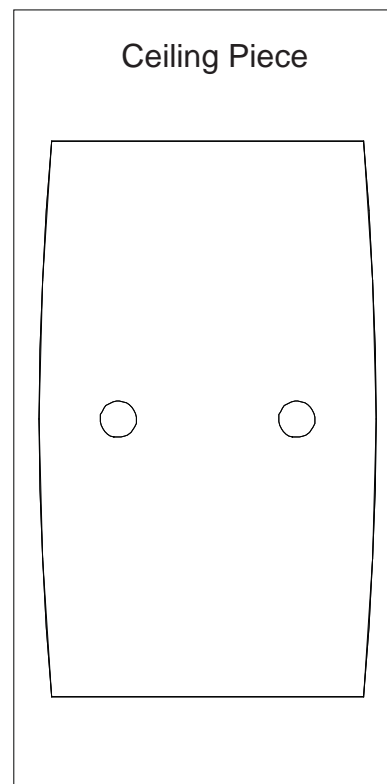

Level 2

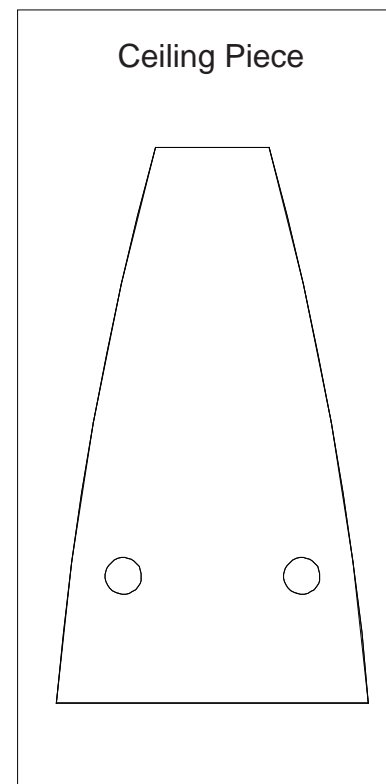

Level 3

WHEN DISASSEMBLING ALUMINUM EXTRUSION, TIGHTEN ALL SETSCREWS AND LOCKS TO PREVENT LOSS DURING SHIPPING

Top View of each Level

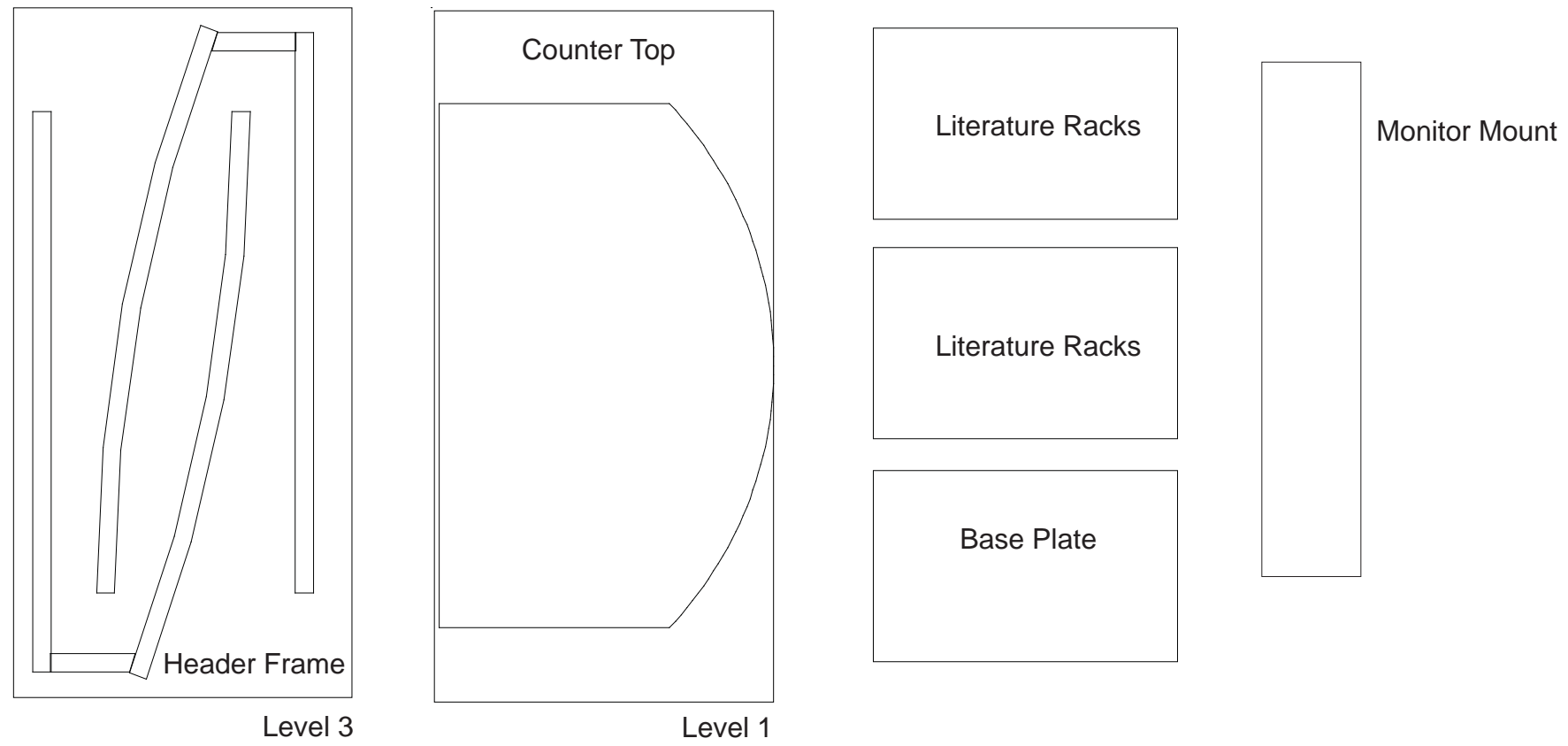

WHEN DISASSEMBLING ALUMINUM EXTRUSION, TIGHTEN ALL SETSCREWS AND LOCKS TO PREVENT LOSS DURING SHIPPING