

visionaryTM
MAGELLAN DESIGNS

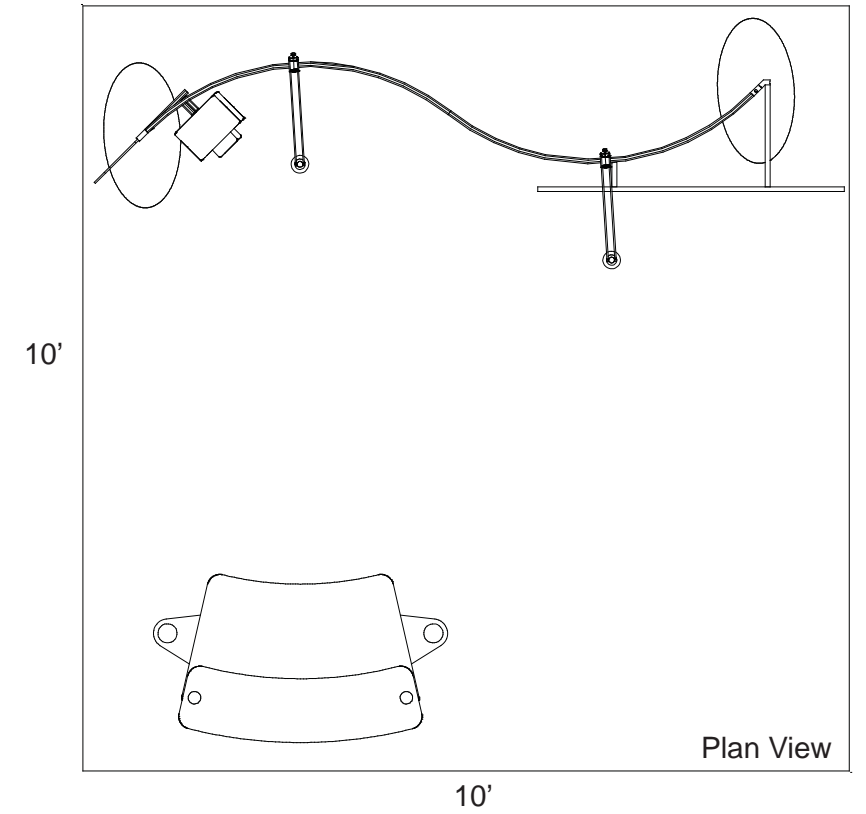
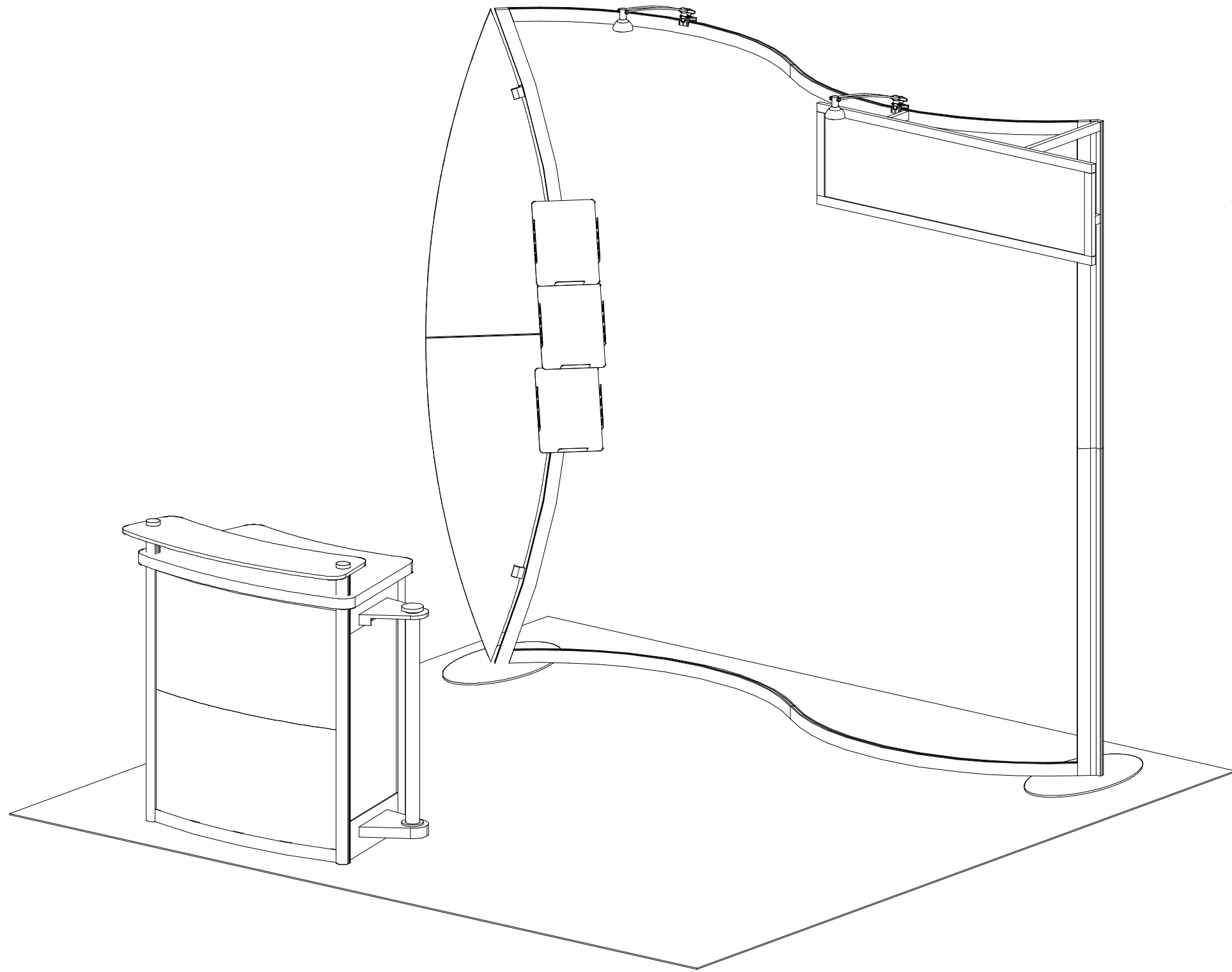

WHEN DISASSEMBLING ALUMINUM EXTRUSION, TIGHTEN ALL SETSCREWS AND LOCKS TO PREVENT LOSS DURING SHIPPING

visionary™ IDESIGNS

Using Your Setup Instructions

The Visionary Designs Setup Instructions are created specifically for your configuration. They are laid out sequentially, including an exploded view of the entire display, and then a logical series of detailed steps to assemble the main structure and components. We encourage you to study the instructions **before** attempting to assemble your exhibit.

Each page reminds you to tighten the setscrews after disassembling your exhibit to prevent loss of the locks and setscrews (see below in RED). This is **VERY IMPORTANT**.

Cleaning and Packing Your Display

- 1) Use care when cleaning aluminum extrusion or acrylic inserts. Use only non-abrasive cleaners.
- 2) When cleaning laminate inserts or countertops, use mild cleansers and a soft material such as cotton.
- 3) Keep all display components away from extreme heat and long exposure to sunlight to avoid warping and fading.
- 4) Retain all packing material. It will make re-packing much easier and will reduce the likelihood of shipping damage.



The Tool

Most Visionary Designs exhibits can be assembled with the supplied Hex Key Tool. Occasionally, a flat head screwdriver may be required.



Typical Connection

Most horizontal extrusion connections have a patented expandable lock. This lock inserts into the groove of an opposing extrusion. Tightening the lock with the Hex Key Tool expands the lock and creates a strong positive connection.



Typical Connection (cont'd)



Detail B

Numbered Label

Each extrusion contains a numbered label which corresponds with setup instructions. The label is located within a groove of the extrusion (when possible). With Visionary Designs the labels contain Black numbers unless otherwise specified.



Detail C

Horizontal Inline Connection (remove only one setscrew)

Remove only (1) setscrew when disassembling. Replace setscrew in extrusion after assembling it. Before packing, replace setscrew in extrusion to avoid losing it.

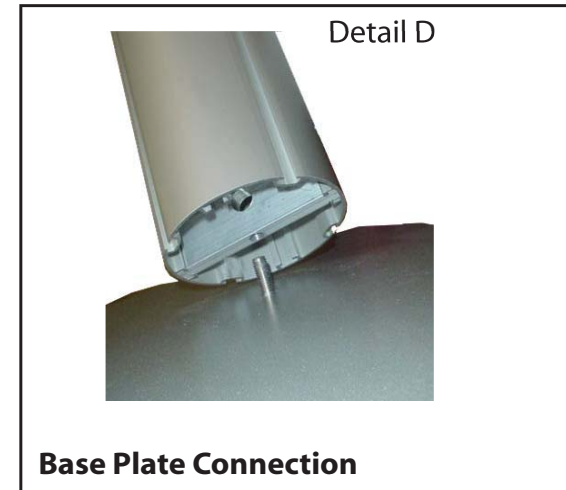

Detail D

Base Plate Connection

Attach base plate to round or square vertical extrusion using the bolt provided. Be careful not to strip the threads.

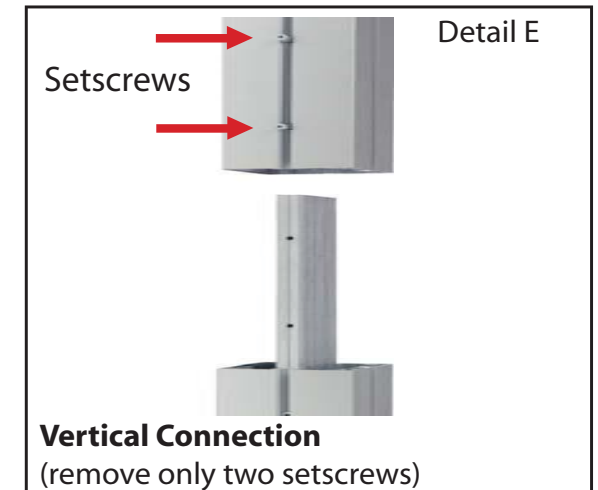

Detail E

Vertical Connection
(remove only two setscrews)

When vertical extrusions are packed in portable cases rather than crates or tubs, they must be broken down into smaller sections which then require assembly.

Remove only (2) setscrews when disassembling. Replace setscrews in extrusion after assembling it. Before packing, replace setscrews in extrusion to avoid losing them.

WHEN DISASSEMBLING ALUMINUM EXTRUSION, TIGHTEN ALL SETSCREWS AND LOCKS TO PREVENT LOSS DURING SHIPPING

866.652.2100

Part Number	Qty	Description
1	2	Base Plate
2	1	48.115" Lower Curved Extrusion
3	1	48.115" Upper Curved Extrusion
4	1	47"h Lower Vertical Extrusion
5	1	47"h Upper Vertical Extrusion
6a/6b	1/1	52.476" Horizontal Curved Extrusion
7a/7b	1/1	52.476" Horizontal Curved Extrusion

Steps:

- 1) Attach vertical extrusions to base plates [2 to 1 and 4 to 1].
- 2) Connect vertical pieces together [2 to 3 and 4/4a to 5/5a].
- 3) Connect curved extrusions together [6a to 6b and 7a to 7b].
- 4) Attach horizontal assemblies [6a/6b and 7a/7b] between

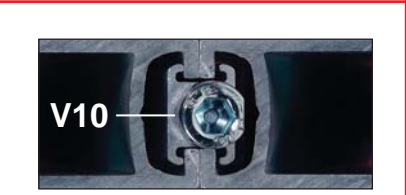
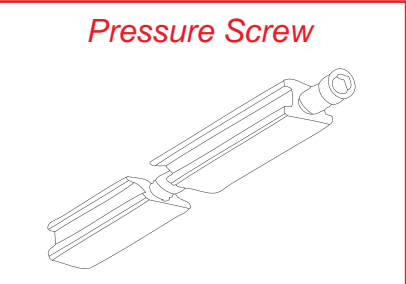
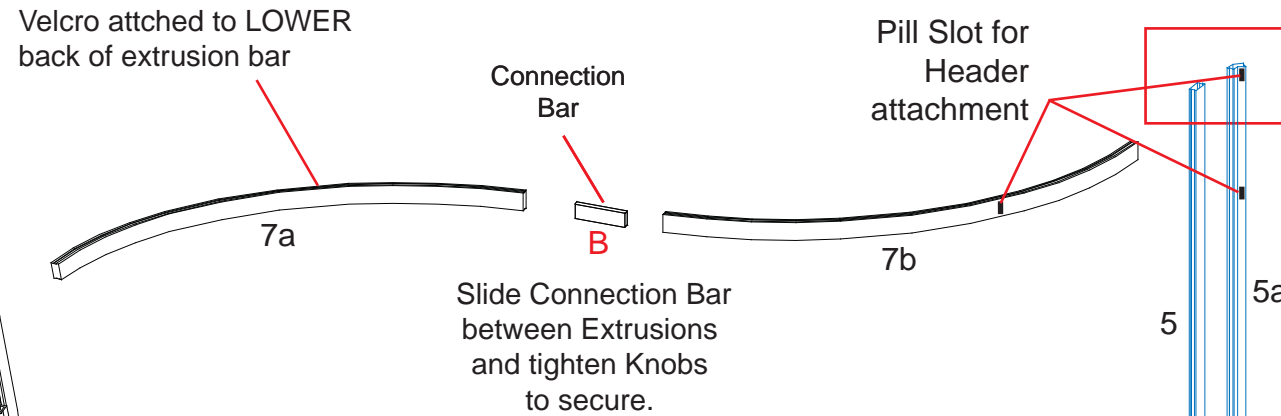

Note: V10 Detail
Slide V10 in between grooves of extrusions #5 and 5a. Tighten to secure.

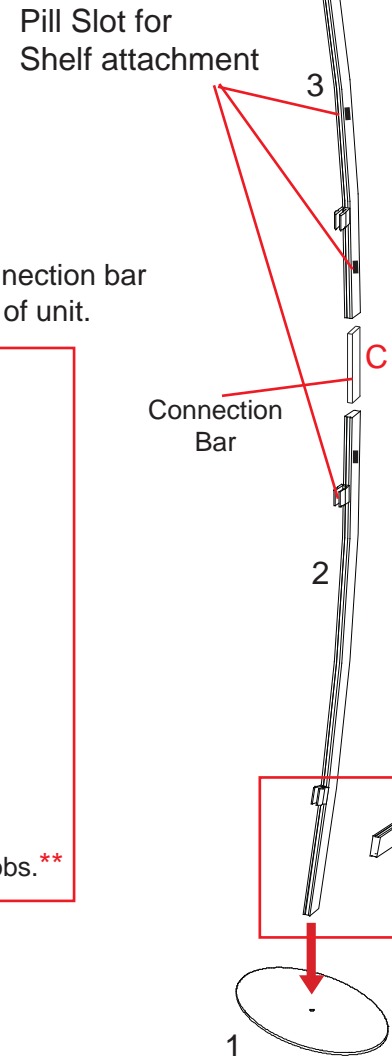

Graphic Attachment
Apply graphics to back of assembled backwall.

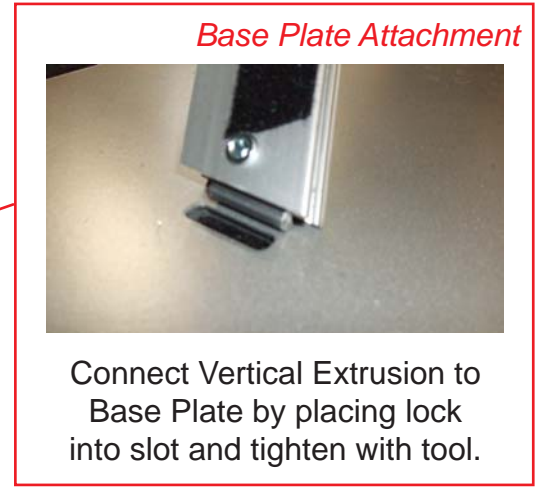
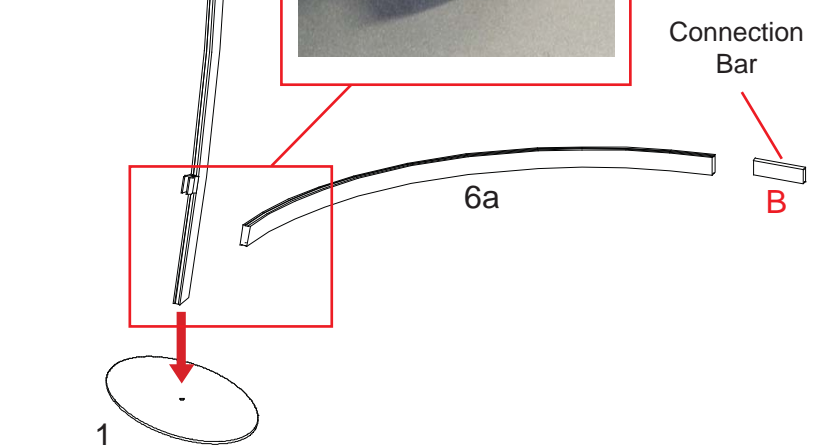
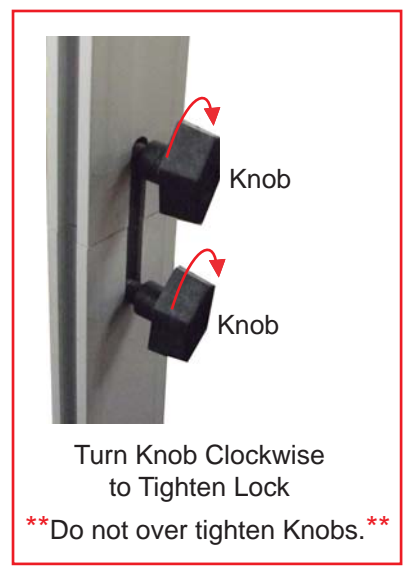
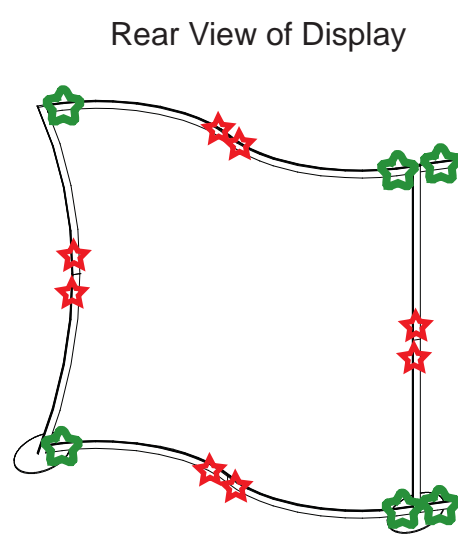

WHEN DISASSEMBLING ALUMINUM EXTRUSION, TIGHTEN ALL SETSCREWS AND LOCKS TO PREVENT LOSS DURING SHIPPING

866.652.2100

Part Number	Qty	Description
15	2	14.52" h Vertical Extrusion
16	2	45.48" w Horizontal Extrusion
17	2	16" w Header Attachment Extrusion
17a	1	3.8462" w Horizontal Extrusion

Steps:

- 1) Assemble header pieces together, placing infill inside frame.
- 2) Attach assembled header with infill to pill slots on backwall where indicated.
- 3) Attach wings to A10 clamps.
- 4) Attach literature shelves to pill slot on left section of frame.
- 5) Attach lights to top of assembled frame.

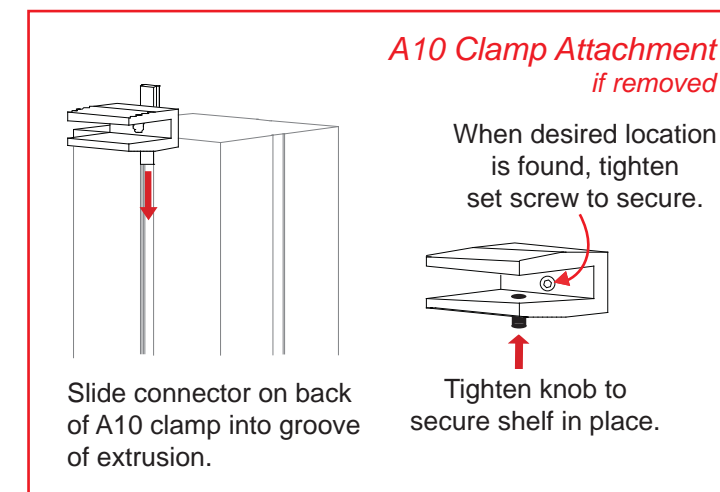
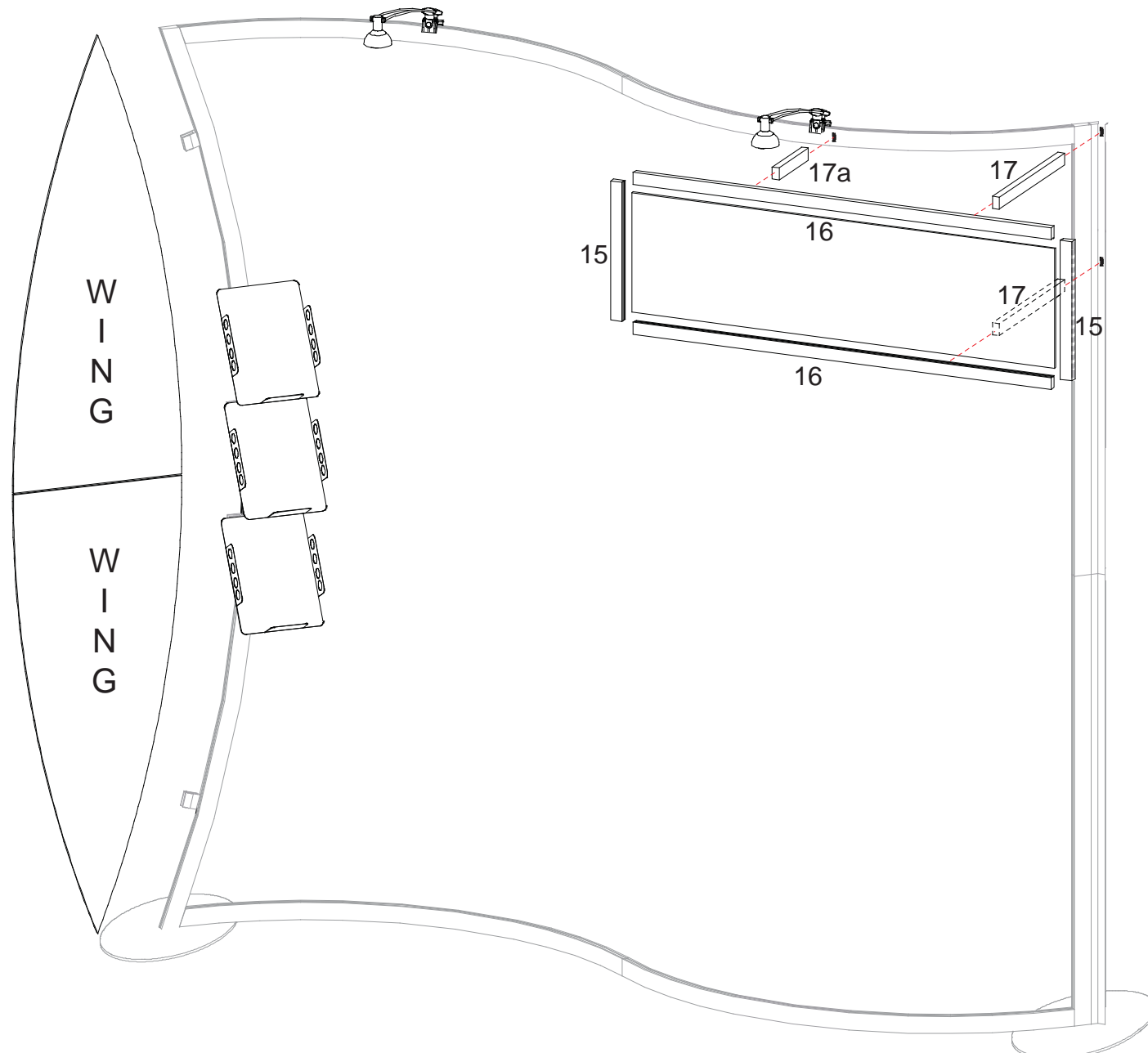
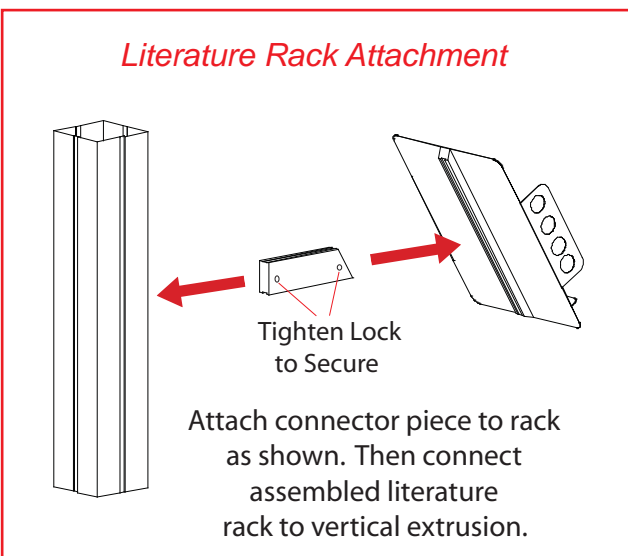
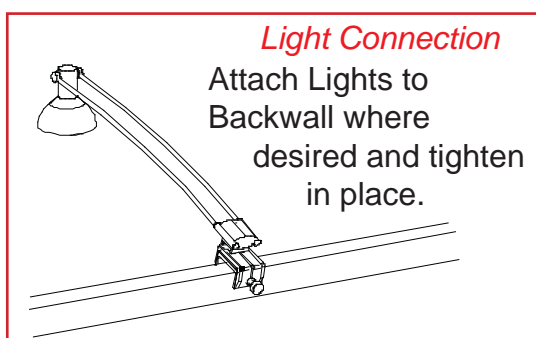

WHEN DISASSEMBLING ALUMINUM EXTRUSION, TIGHTEN ALL SETSCREWS AND LOCKS TO PREVENT LOSS DURING SHIPPING

866.652.2100

Item	Quantity	Description
18	1	42" h Round Vertical Extrusion
19	1	38" h Round Vertical Extrusion w/ Door Stopper
20	1	38" h Round Vertical Extrusion w/ Hinges
21	1	42" h Round Vertical Extrusion
22	2	31.85" Curved Horizontal Extrusion
23	2	23.8" Curved Horizontal Extrusion
24	4	16" w Horizontal Extrusion
25	2	31" h Round Vertical

Steps:

- 1) Attach lower horizontal extrusions [22, 23 and 24] between vertical extrusions [18, 19, 20 and 21] as shown.
- 2) Place inserts and door where indicated.
- 3) Attach upper horizontal extrusions [22, 23 and 24] between vertical extrusions [18, 19, 20 and 21].
- 4) Attach wood pieces to horizontals on both sides of pedestal as shown.
- 5) Place product roll between wood pieces then secure with round vertical as shown.
- 6) Velcro internal shelf supports to inside assembled pedestal
- 7) Set internal shelf atop shelf supports
- 8) Slide counter top on vertical extrusions [1 and 4] and rest atop pedestal.
- 9) Attach plex shelf using caps.

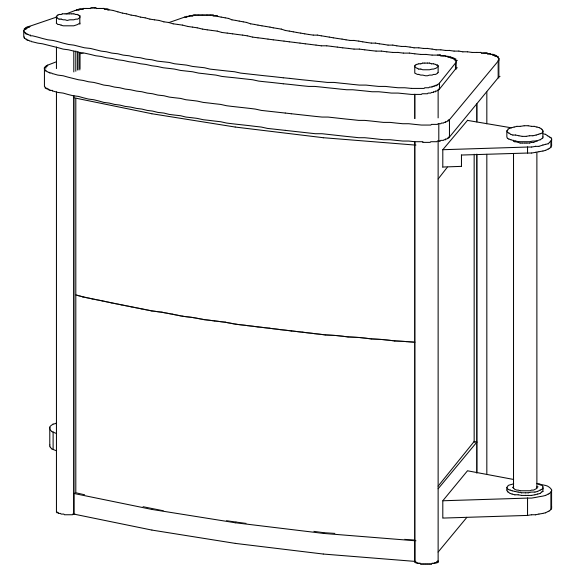

Door Attachment

Slide pin into hinge attached to vertical.
Slide door hinge atop pin.

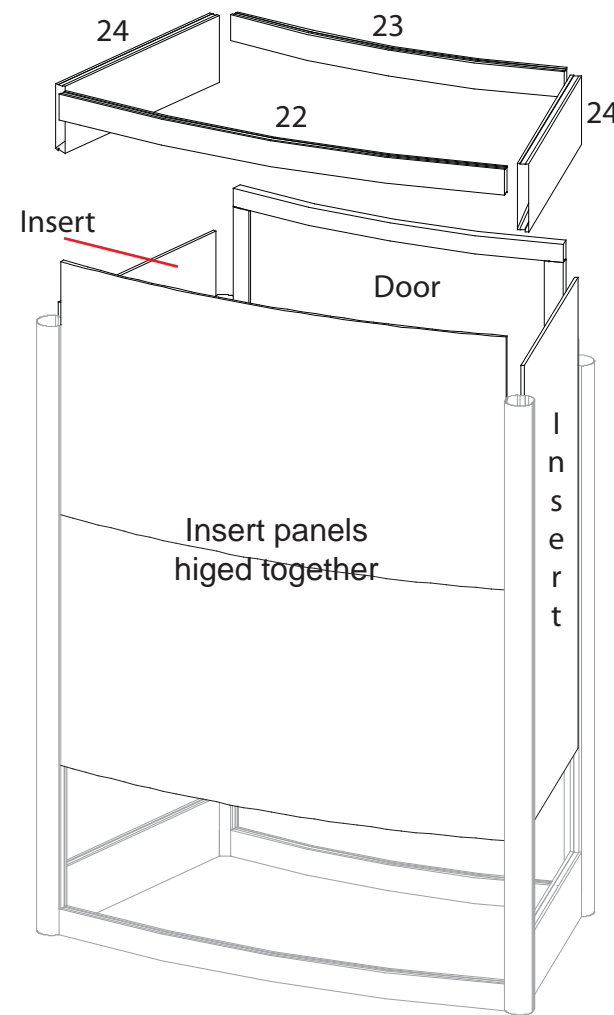
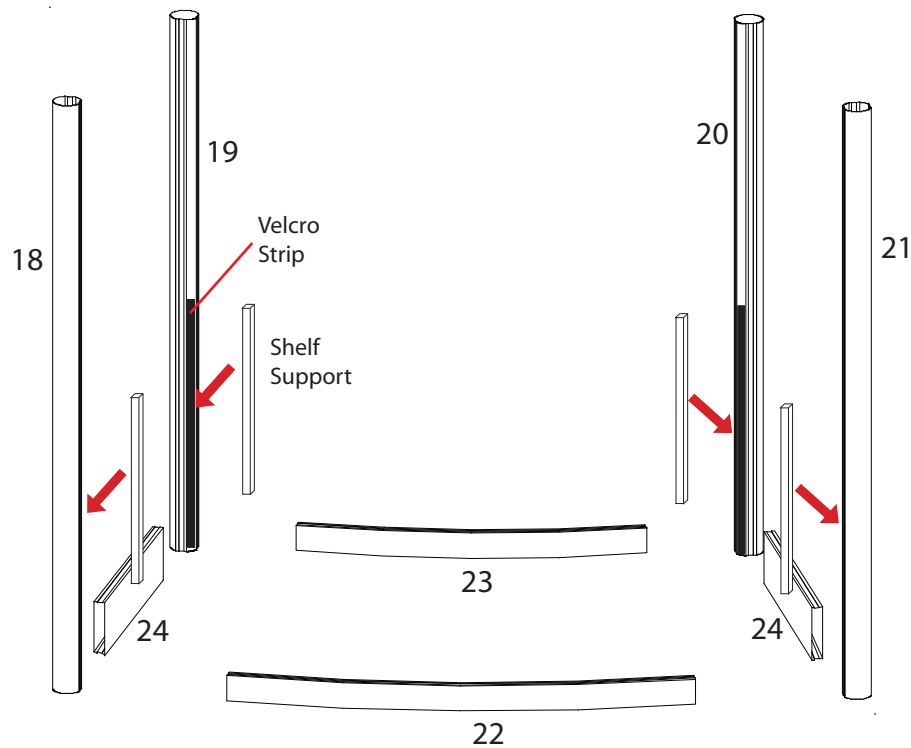
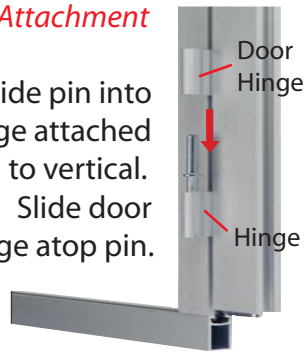

Product Holder

Place product roll between wood pieces then secure with round vertical.

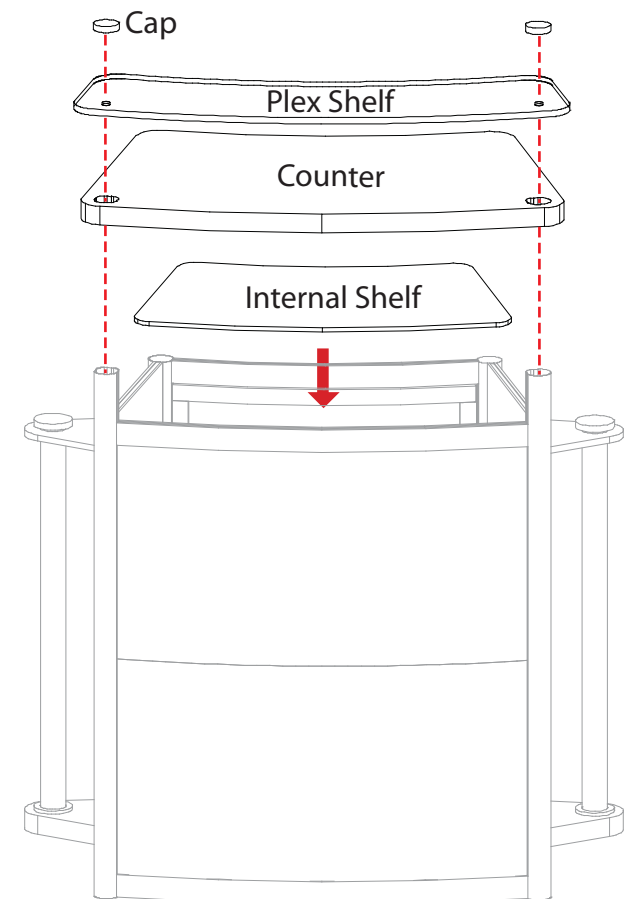
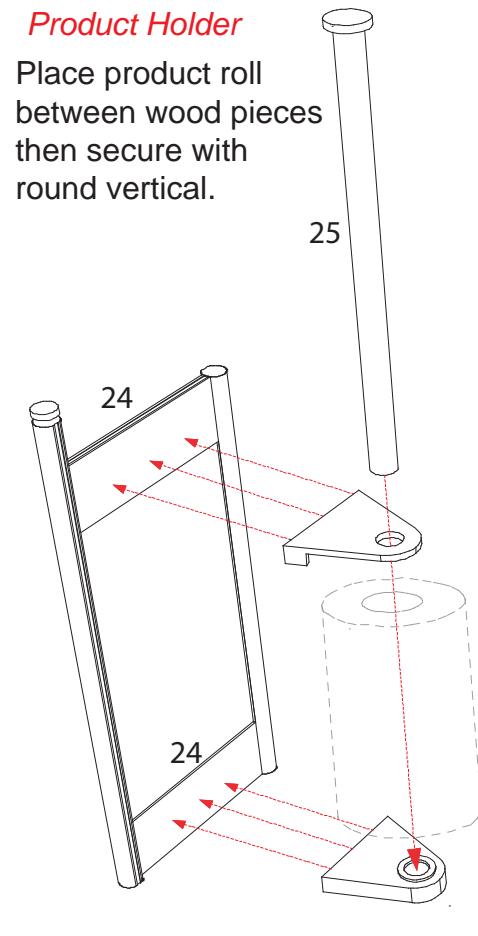

WHEN DISASSEMBLING ALUMINUM EXTRUSION, TIGHTEN ALL SETSCREWS AND LOCKS TO PREVENT LOSS DURING SHIPPING