

WHEN DISASSEMBLING ALUMINUM EXTRUSION, TIGHTEN ALL SETSCREWS AND LOCKS TO PREVENT LOSS DURING SHIPPING

visionary™ DESIGNS

Using Your Setup Instructions

The Visionary Designs Setup Instructions are created specifically for your configuration. They are laid out sequentially, including an exploded view of the entire display, and then a logical series of detailed steps to assemble the main structure and components. We encourage you to study the instructions **before** attempting to assemble your exhibit.

Each page reminds you to tighten the setscrews after disassembling your exhibit to prevent loss of the locks and setscrews (see below in RED). This is **VERY IMPORTANT**.

Cleaning and Packing Your Display

- 1) Use care when cleaning aluminum extrusion or acrylic inserts. Use only non-abrasive cleaners.
- 2) When cleaning laminate inserts or countertops, use mild cleansers and a soft material such as cotton.
- 3) Keep all display components away from extreme heat and long exposure to sunlight to avoid warping and fading.
- 4) Retain all packing material. It will make re-packing much easier and will reduce the likelihood of shipping damage.



The Tool

Most Visionary Designs exhibits can be assembled with the supplied Hex Key Tool. Occasionally, a flat head screwdriver may be required.



Typical Connection

Most horizontal extrusion connections have a patented expandable lock. This lock inserts into the groove of an opposing extrusion. Tightening the lock with the Hex Key Tool expands the lock and creates a strong positive connection.



Typical Connection (cont'd)



Detail B

Numbered Label

Each extrusion contains a numbered label which corresponds with setup instructions. The label is located within a groove of the extrusion (when possible). With Visionary Designs the labels contain Black numbers unless otherwise specified.



Detail C

Horizontal Inline Connection (remove only one setscrew)

Remove only (1) setscrew when disassembling. Replace setscrew in extrusion after assembling it. Before packing, replace setscrew in extrusion to avoid losing it.

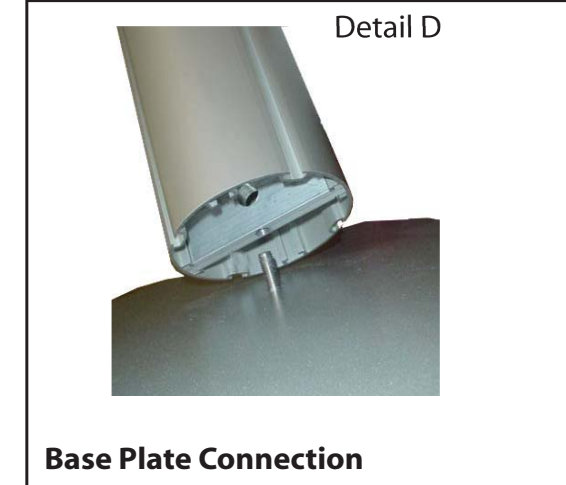

Detail D

Base Plate Connection

Attach base plate to round or square vertical extrusion using the bolt provided. Be careful not to strip the threads.

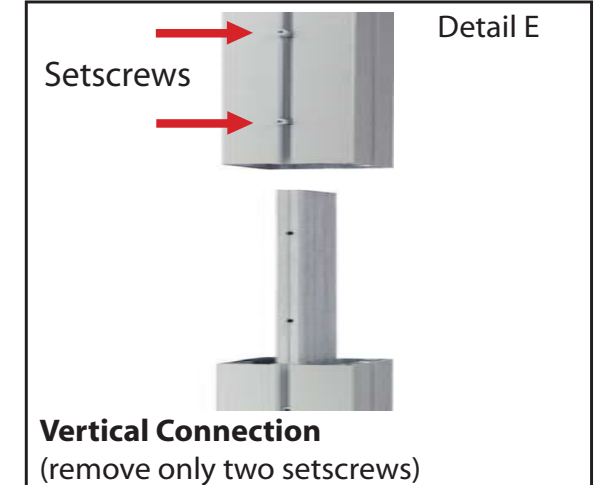

Detail E

Vertical Connection
(remove only two setscrews)

When vertical extrusions are packed in portable cases rather than crates or tubs, they must be broken down into smaller sections which then require assembly.

Remove only (2) setscrews when disassembling. Replace setscrews in extrusion after assembling it. Before packing, replace setscrews in extrusion to avoid losing them.

WHEN DISASSEMBLING ALUMINUM EXTRUSION, TIGHTEN ALL SETSCREWS AND LOCKS TO PREVENT LOSS DURING SHIPPING

Number	QTY.	Description
1	3	Base Plates
7	1	84" Vertical Extrusion w/ Canopy Attachments
8	1	84" Vertical Extrusion
9	1	84" Vertical Extrusion w/ Canopy Attachments
10	2	60.125"w Horizontal Extrusion
11	2	20.25"w Horizontal Extrusion

- Steps:
- 1) Attach vertical extrusions [7, 8 and 9] to base plates [1].
 - 2) Attach horizontal extrusions [10 and 11] between verticals [7, 8 and 9].
- Note: Opening of SEG extrusion must face forward***

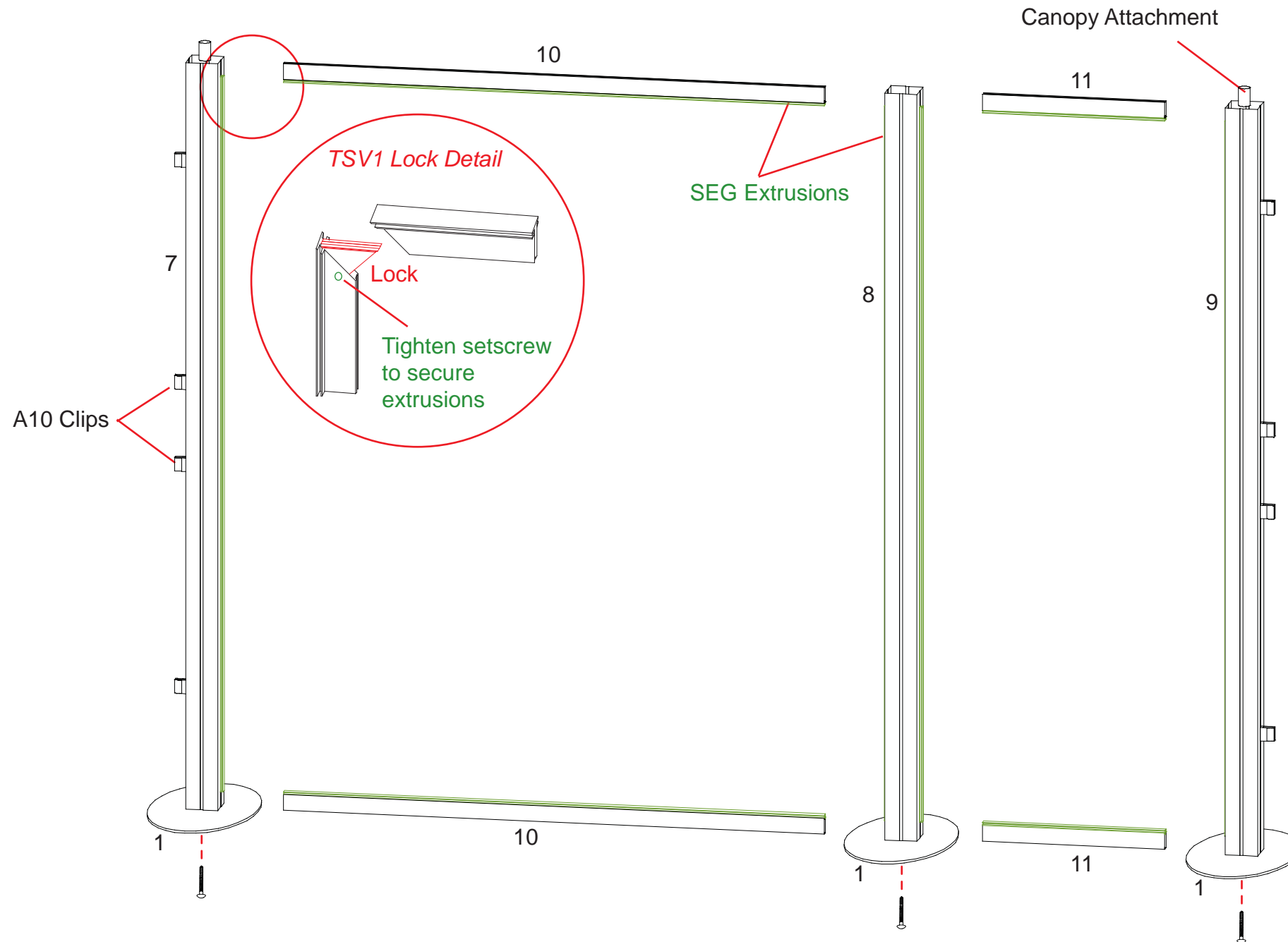

WHEN DISASSEMBLING ALUMINUM EXTRUSION, TIGHTEN ALL SETSCREWS AND LOCKS TO PREVENT LOSS DURING SHIPPING

866.652.2100

Steps:

- 1) Attach wing panels to A10 clips as shown.
- 2) Lock shelves with supports to vertical extrusions where desired.
- 3) Attach light to top of assembled backwall where desired.
- 4) Attach monitor mount to assembled backwall where indicated.

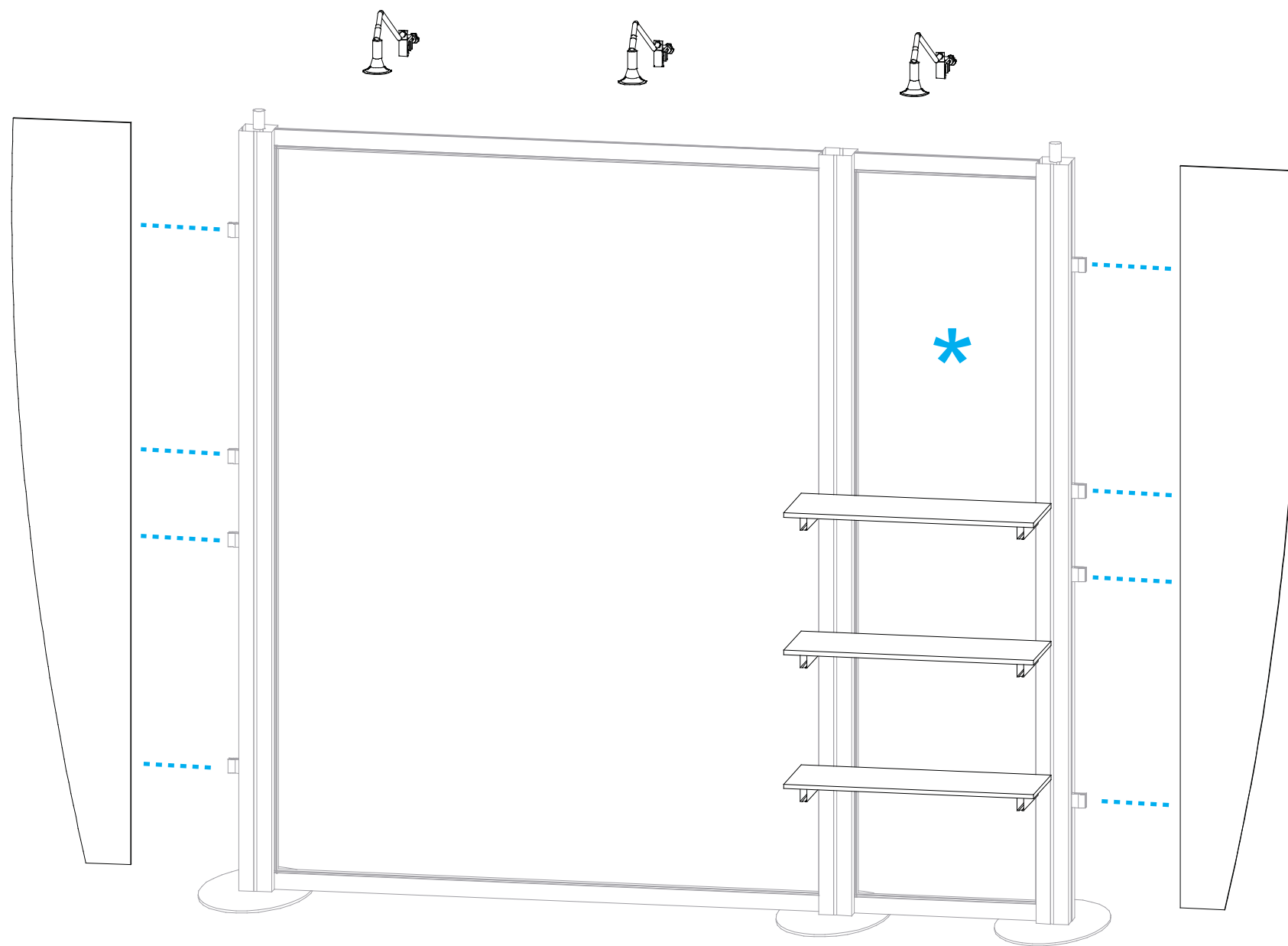
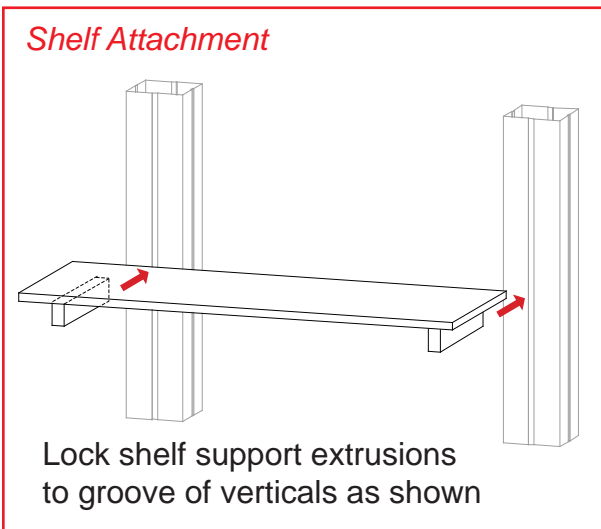
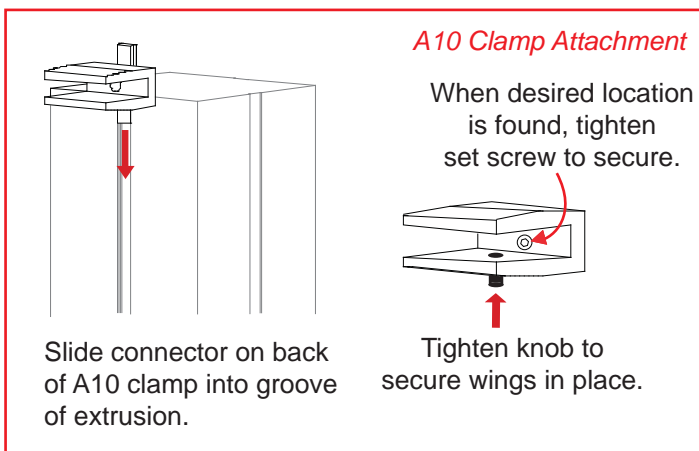
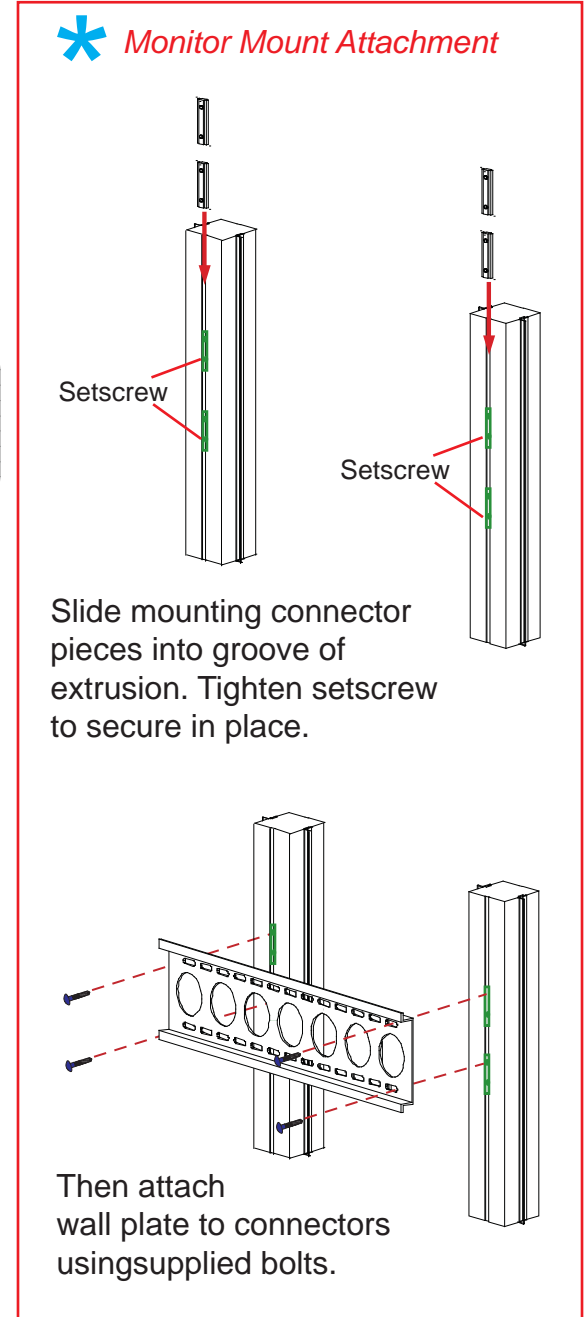
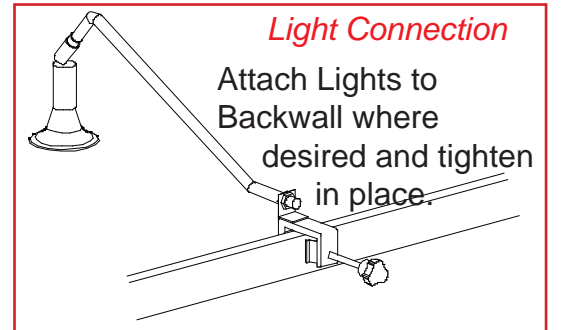

WHEN DISASSEMBLING ALUMINUM EXTRUSION, TIGHTEN ALL SETSCREWS AND LOCKS TO PREVENT LOSS DURING SHIPPING

Item	Quantity	Description
A	1	38" Round extrusion
AB	1	38" Round extrusion
B	1	38" Round extrusion
C	1	38" Round extrusion
CD	1	38" Round extrusion
D	1	38" Round extrusion
E	2	14.25" Round extrusion

Steps:

- 1) Connect (A) round extrusion to (AB) round extrusion.
- 2) Connect (AB) round extrusion to (B) round extrusion.
- 3) Connect (C) round extrusion to (CD) round extrusion.
- 4) Connect (CD) round extrusion to (D) round extrusion.
- 5) Connect (A) round extrusion and (D) round extrusion to (E) extrusion.
- 6) Connect (B) round extrusion and (C) round extrusion to (E) extrusion.
- 7) Attach Canopy Assembly to Vertical extrusions with Canopy attachments.

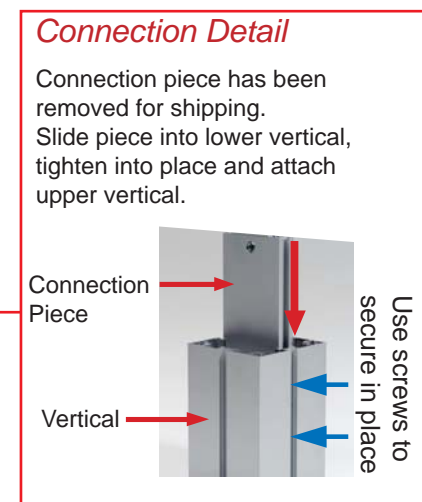
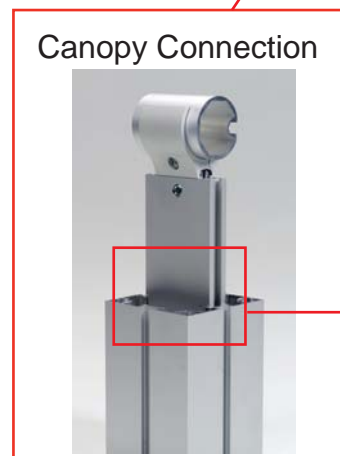
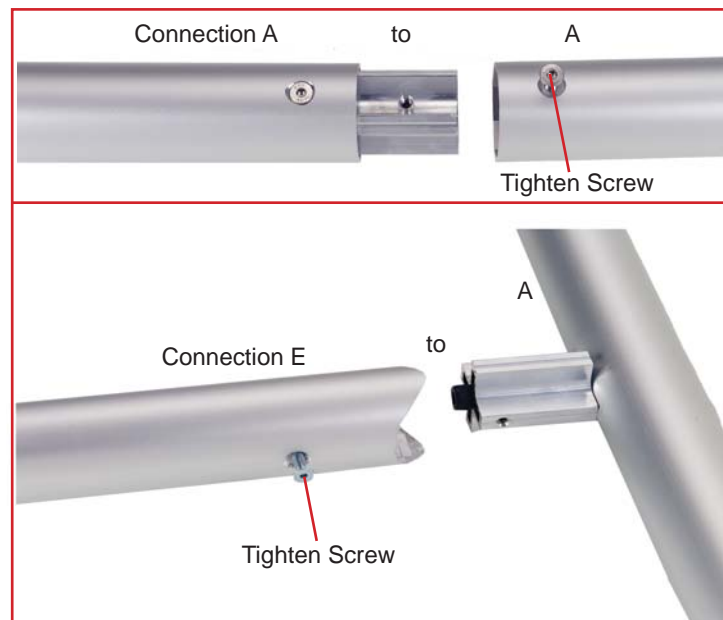
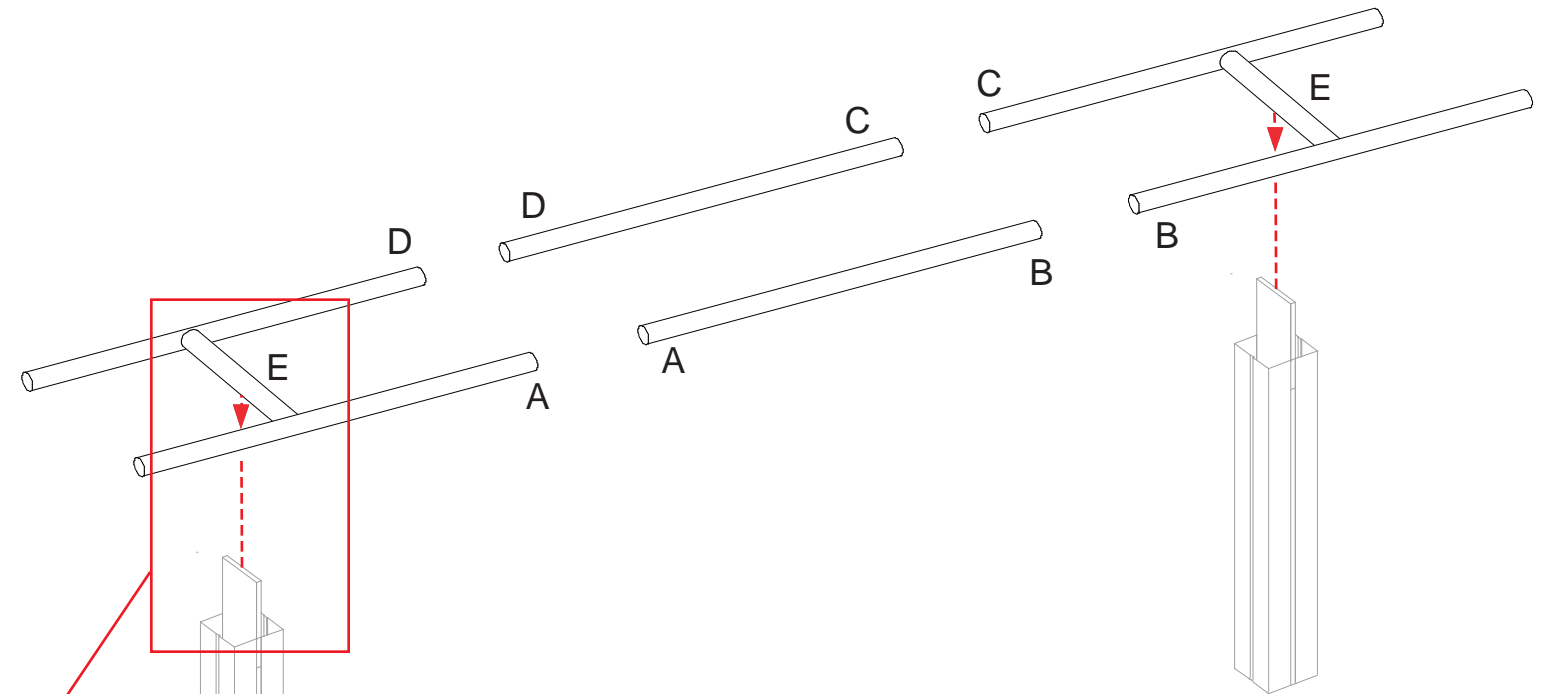

WHEN DISASSEMBLING ALUMINUM EXTRUSION, TIGHTEN ALL SETSCREWS AND LOCKS TO PREVENT LOSS DURING SHIPPING

866.652.2100

Number	QTY.	Description
12	1	Base Plates
13	1	31.5" Vertical Extrusion
14	1	31.5" Vertical Extrusion
15	1	20.25"w Horizontal Extrusion
15a	2	60.125"w Horizontal Extrusion
16	3	3"w Shelf Support

Steps:

- 1) Attach vertical extrusion [13] to base plate [12].
- 2) Lock extrusions [15a] to pill slots on both sides of [15] to create shelf support.
- 3) Attach assembled shelf support to vertical, then place counter atop support.
- 4) Lock extrusions [16] to vertical [14] and set flush to top of vertical, then place small counter top [16]'s.

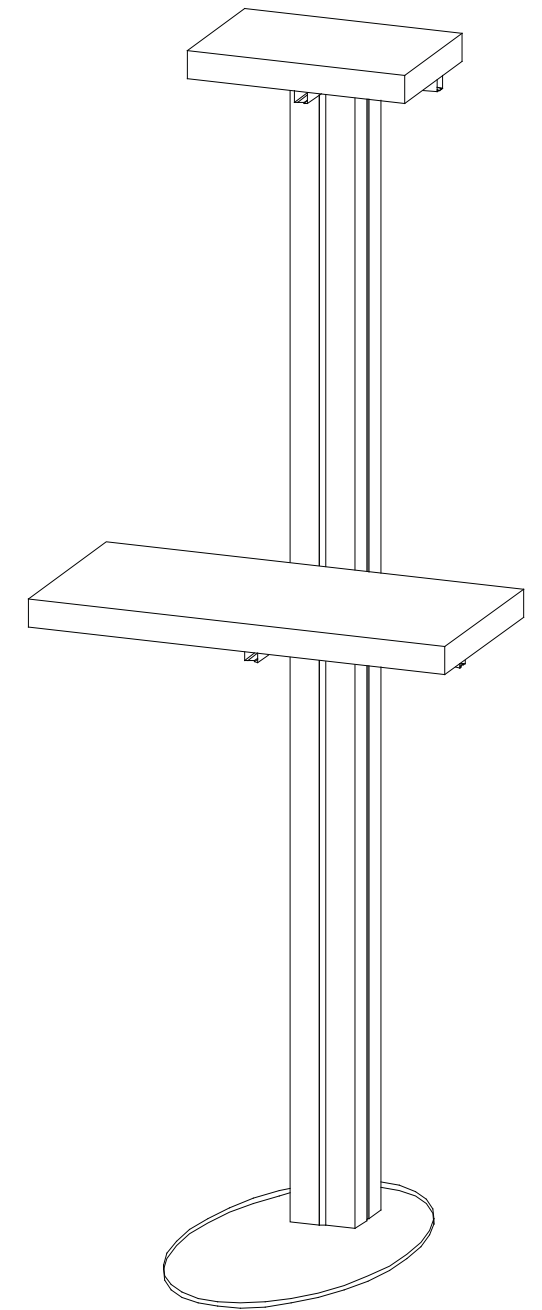
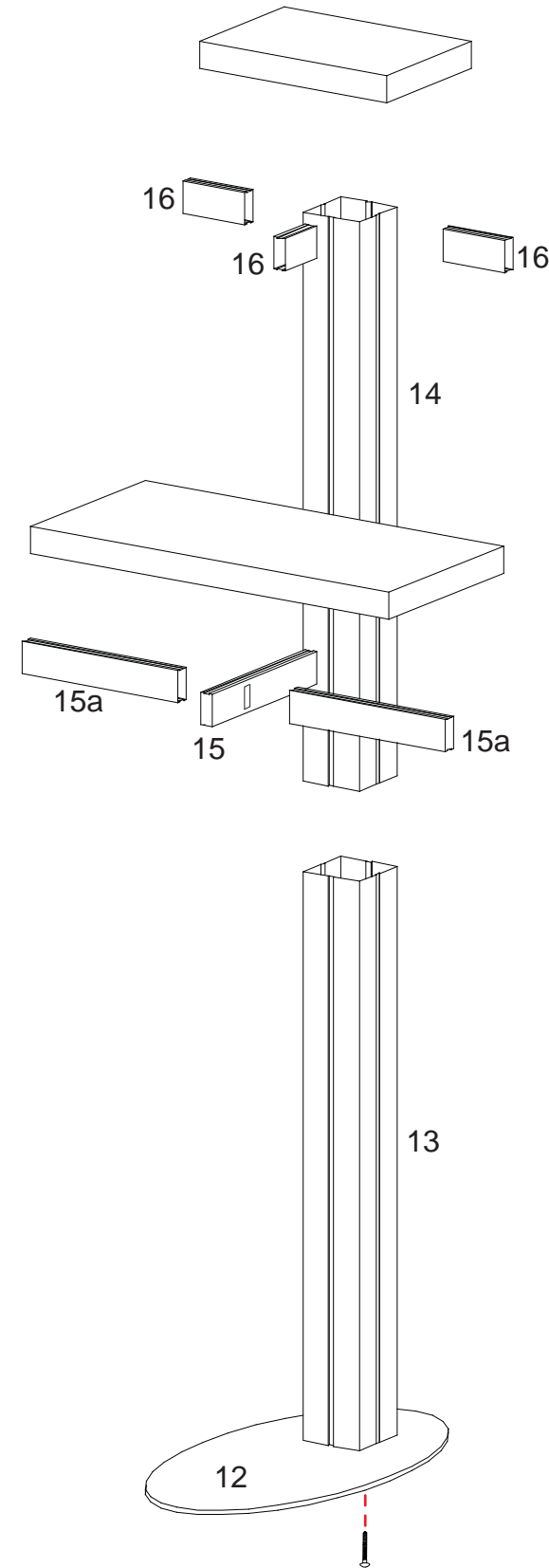

WHEN DISASSEMBLING ALUMINUM EXTRUSION, TIGHTEN ALL SETSCREWS AND LOCKS TO PREVENT LOSS DURING SHIPPING

866.652.2100

Number	QTY.	Description
18	1	38" h Vertical Extrusion
19	1	38" Vertical Extrusion
20	1	38" Vertical Extrusion w/ Door Hinges
21	1	38" Vertical Extrusion w/ Door Stop
22	4	31.5" w Horizontal Extrusion
23	4	14.582" w Horizontal Extrusion
24	1	Literature Shelf Attachment

- Steps:
- 1) Connect front and back assemblies together using horizontals [23], placing inserts as shown.
 - 2) Set counter top on assembled pedestal.
 - 3) Attach literature shelf and side shelf to desired side as shown.

Front and Back assemblies must remain assembled when packing in crate

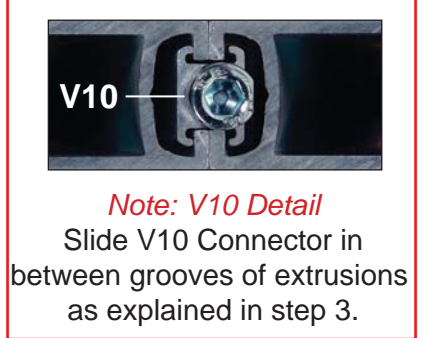
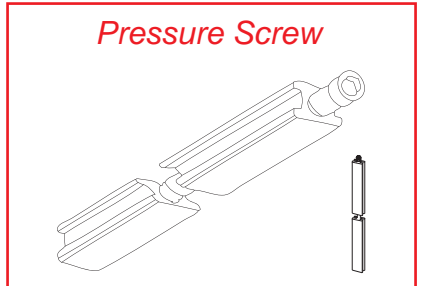
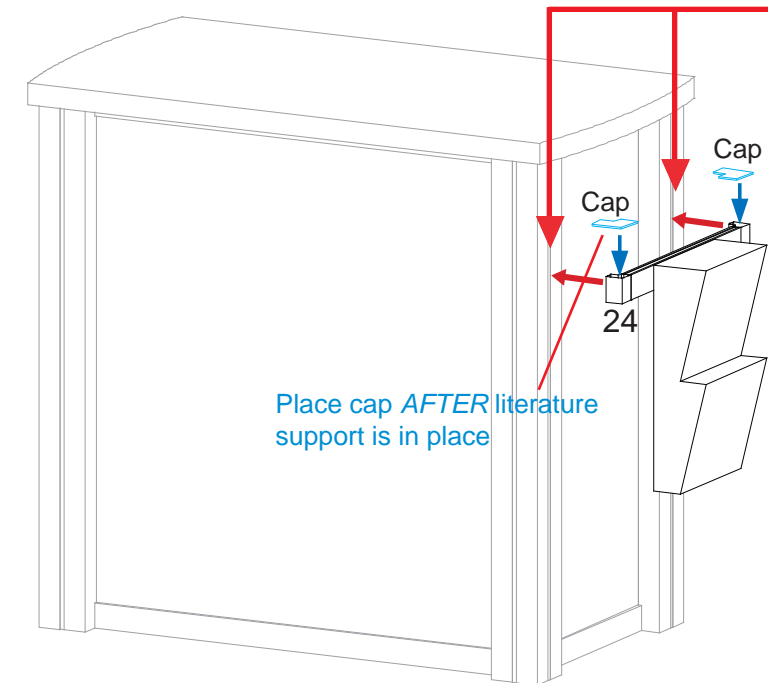
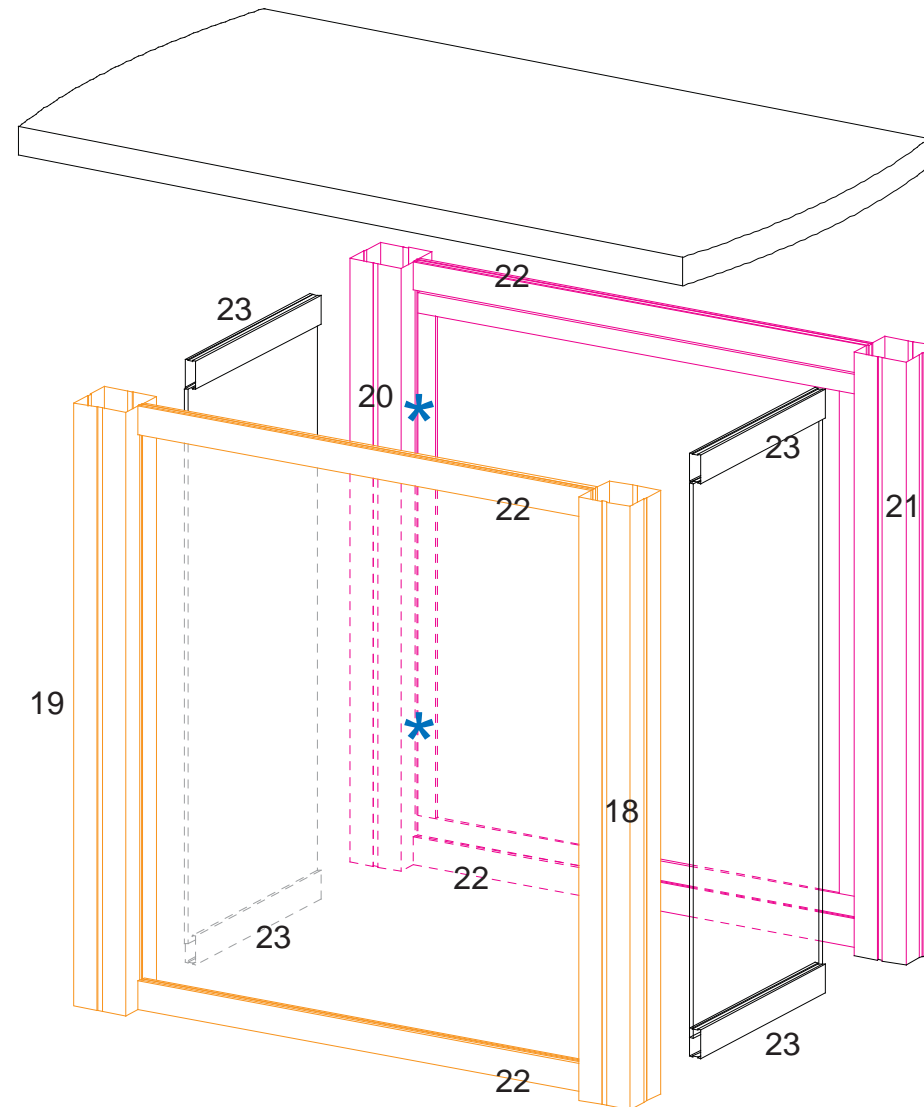
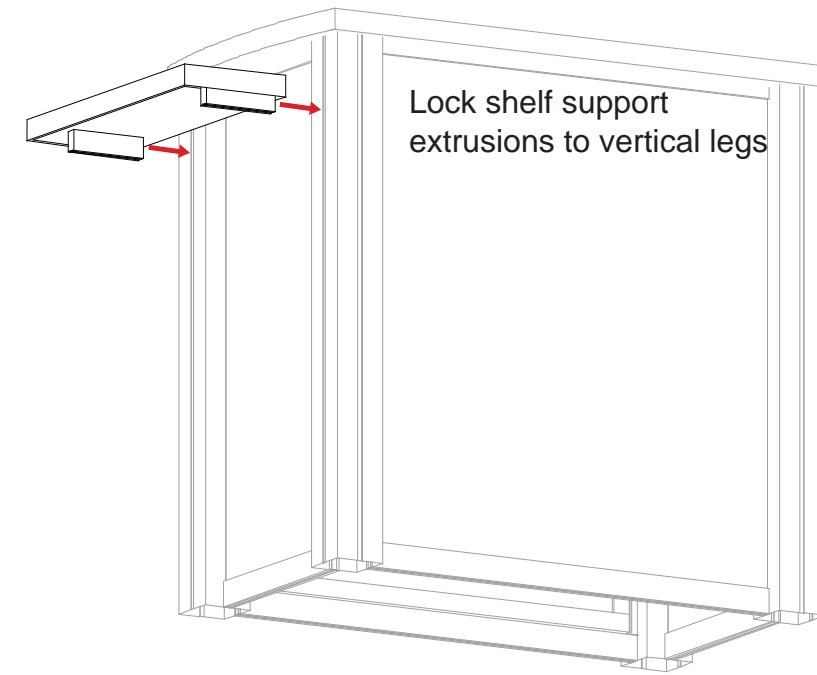

WHEN DISASSEMBLING ALUMINUM EXTRUSION, TIGHTEN ALL SETSCREWS AND LOCKS TO PREVENT LOSS DURING SHIPPING

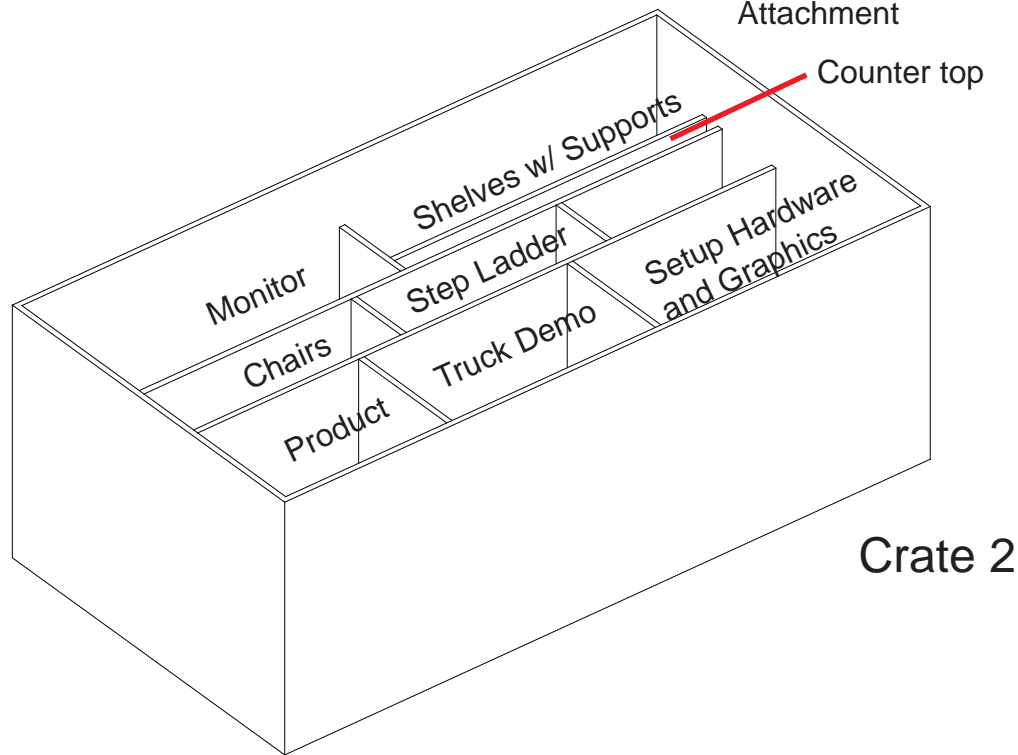
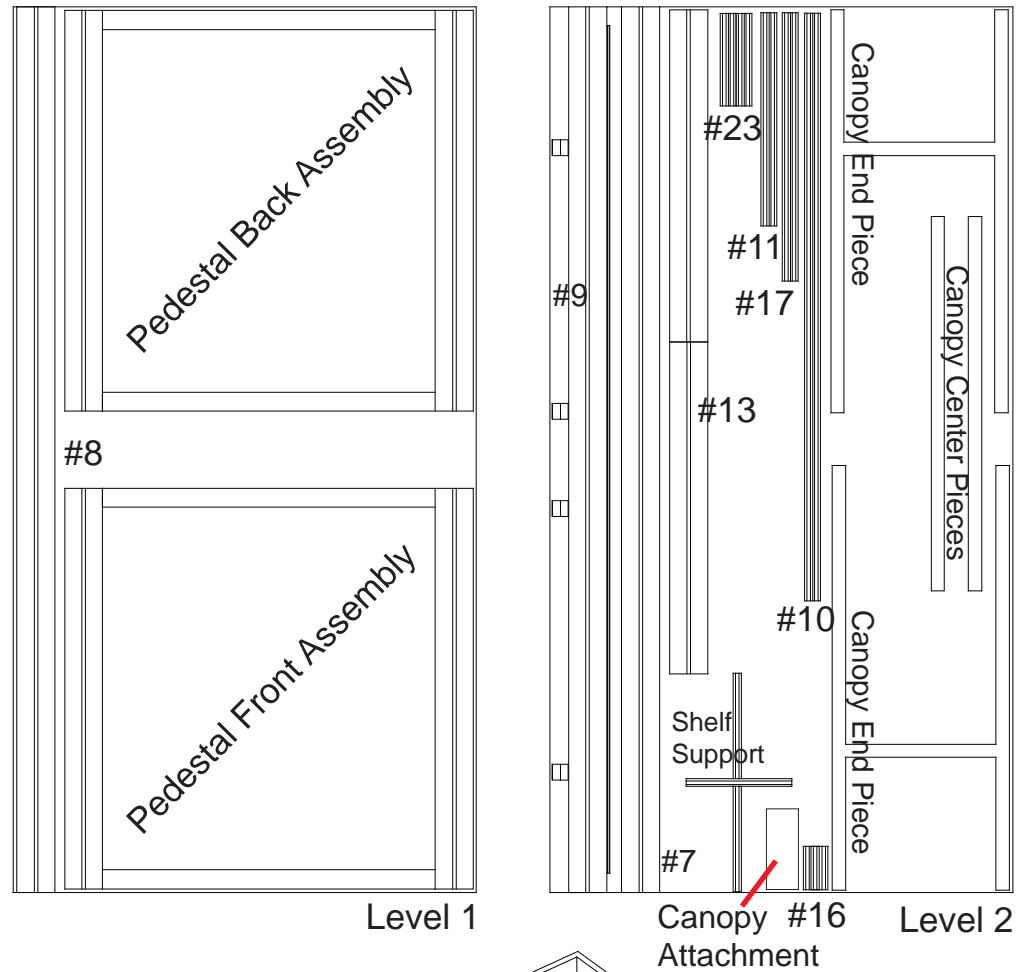

Infills



WHEN DISASSEMBLING ALUMINUM EXTRUSION, TIGHTEN ALL SETSCREWS AND LOCKS TO PREVENT LOSS DURING SHIPPING