

euro It | *HYBRIDS*

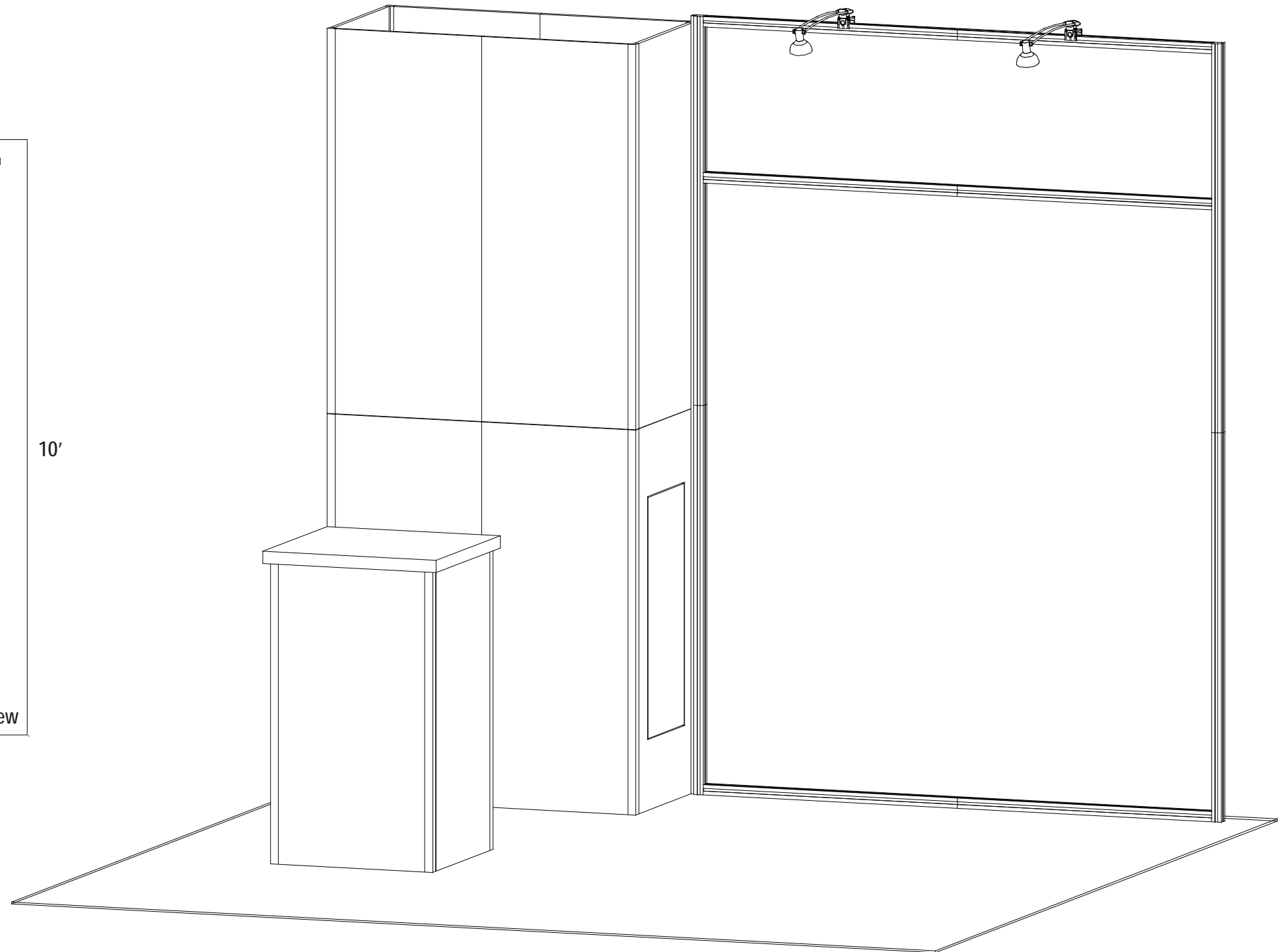
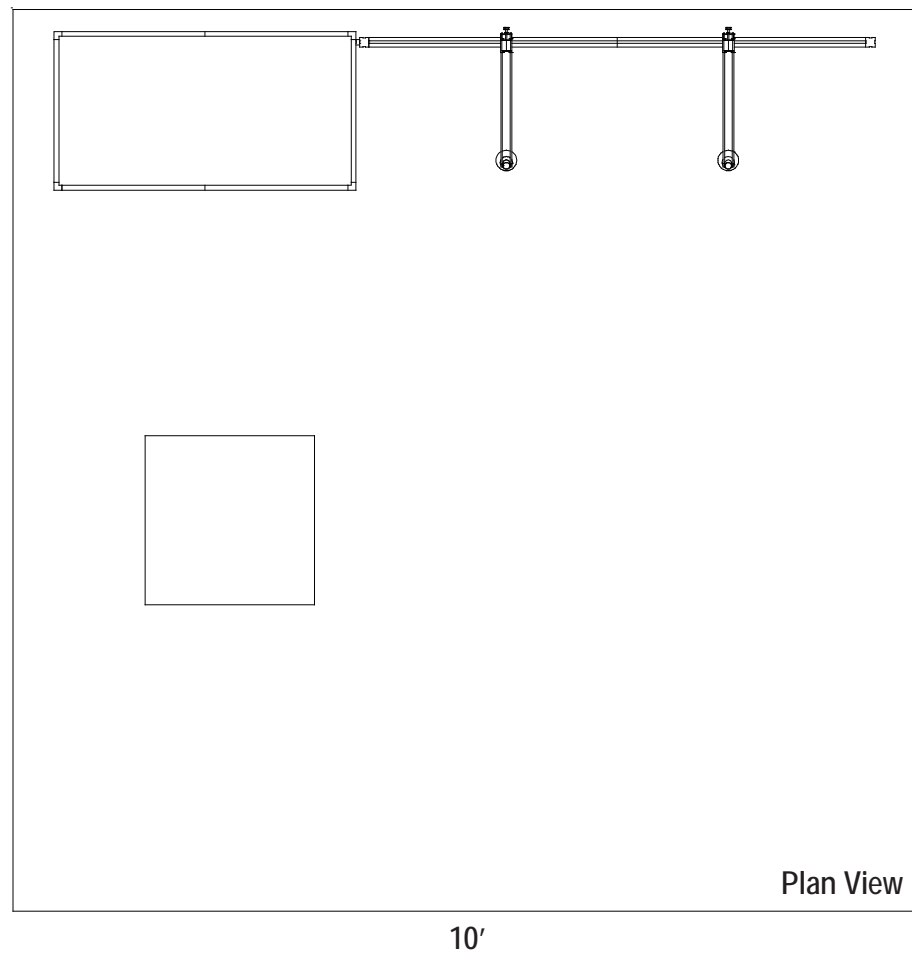

WHEN DISASSEMBLING ALUMINUM EXTRUSION, TIGHTEN ALL SETSCREWS AND LOCKS TO PREVENT LOSS DURING SHIPPING

euro lt | HYBRIDS

Using Your Setup Instructions

The Euro LT Hybrids Setup Instructions are created specifically for your configuration. They are laid out sequentially in levels, including exploded views, and a logical series of detailed steps to assemble the main structure and components. We encourage you to study the instructions **before** attempting to assemble your exhibit.

Each page reminds you to tighten the setscrews after disassembling your exhibit to prevent loss of the locks and setscrews (see below in RED). This is VERY IMPORTANT.

Cleaning and Packing Your Display

- 1) Use care when cleaning aluminum extrusion or acrylic inserts. Use only non-abrasive cleaners.
- 2) When cleaning laminate inserts, countertops, or panels use mild cleansers and a soft material such as cotton.
- 3) Keep all display components away from extreme heat and long exposure to sunlight to avoid warping and fading.
- 4) Retain all packing material. It will make re-packing much easier and will reduce the likelihood of shipping damage.

General Setup Instructions for Extrusion System



Most exhibits can be assembled with the supplied Hex Key Tool. Occasionally, a flat head screwdriver may be required.



Most horizontal extrusion connections have a patented expandable lock. This lock inserts into the groove of an opposing extrusion. Tightening the lock with the Hex Key Tool expands the lock and creates a strong positive connection.

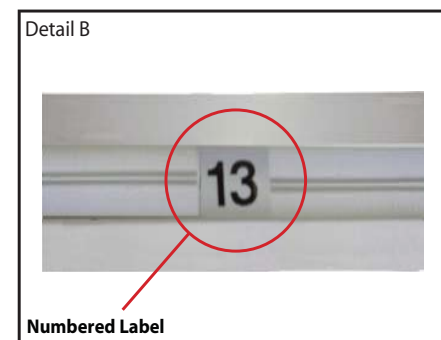

Each extrusion contains a numbered label which corresponds with setup instructions. The label is located within a groove of the extrusion (when possible). With extrusion components the labels contain Black numbers unless otherwise specified.



Remove only (1) setscrew when disassembling. Replace setscrew in extrusion after assembling it. Before packing, replace setscrew in extrusion to avoid losing it.

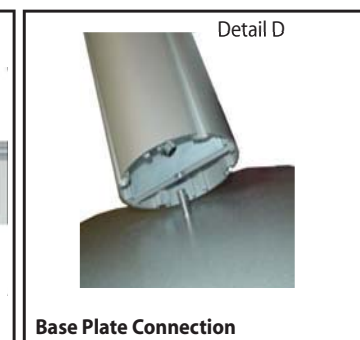

Attach base plate to round or square vertical extrusion using the bolt provided. Be careful not to strip the threads.

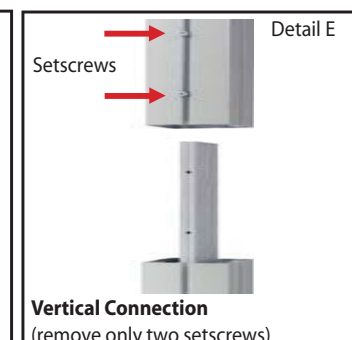

When vertical extrusions are packed in portable cases rather than crates or tubs, they must be broken down into smaller sections which then require assembly.

Remove only (2) setscrews when disassembling. Replace setscrew in extrusion after assembling it. Before packing, replace setscrew in extrusion to avoid losing the

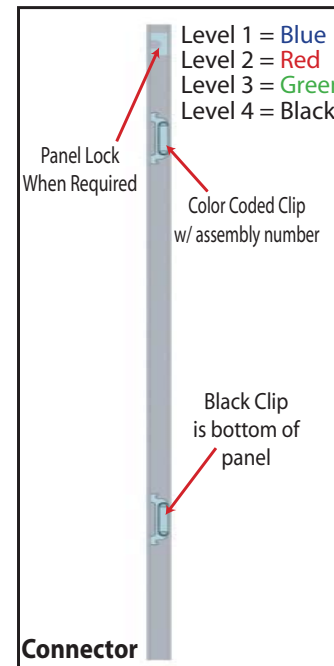

Each component has 2 clips, the lower clip is ALWAYS black. The top clip is color coded to distinguish which level. The color coded clip also contains the numbered label.

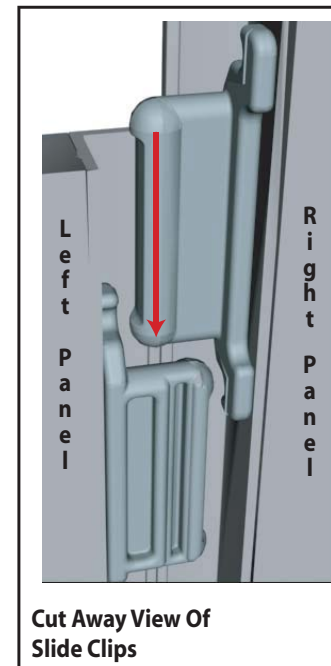

Components connect together by aligning them and sliding downward connecting clips together.

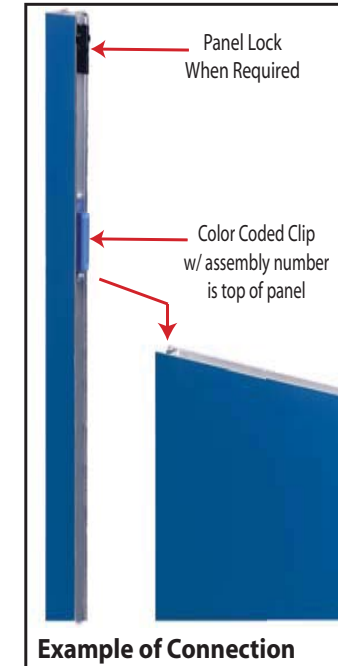

Configurations are assembled from left to right, usually starting with #1 and following the numbered sequence.

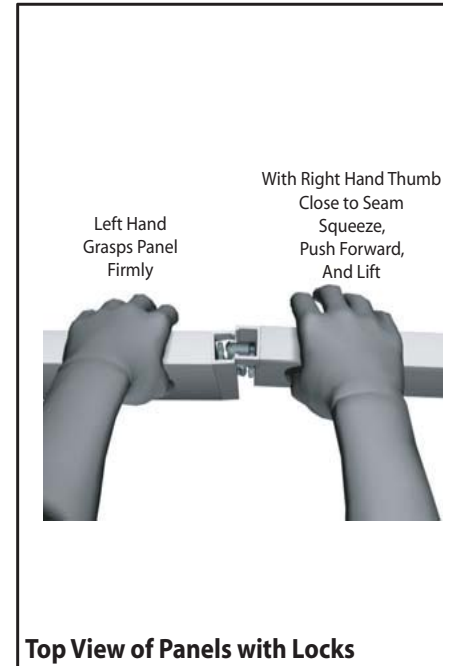

The first level of components contain panel locks that are located at the top of the panel for extra stability and seamless connection. When disassembling panels twist top connection slightly and lift right panel upward.



WHEN DISASSEMBLING ALUMINUM EXTRUSION, TIGHTEN ALL SETSCREWS AND LOCKS TO PREVENT LOSS DURING SHIPPING

Item Number	Description
1	19"w x 47.5"h Flat Panel
2	19"w x 47.5"h Flat Panel
3	47.5"h 90° Connector
4	19"w x 47.5"h Flat Panel
5	47.5"h 90° Connector
6	19"w x 47.5"h Flat Panel
7	19"w x 47.5"h Flat Panel
8	47.5"h 90° Connector
9	19"w x 47.5"h Flat Panel
10	47.5"h 90° Connector

Steps:

1) Connect panels together in numerical order.

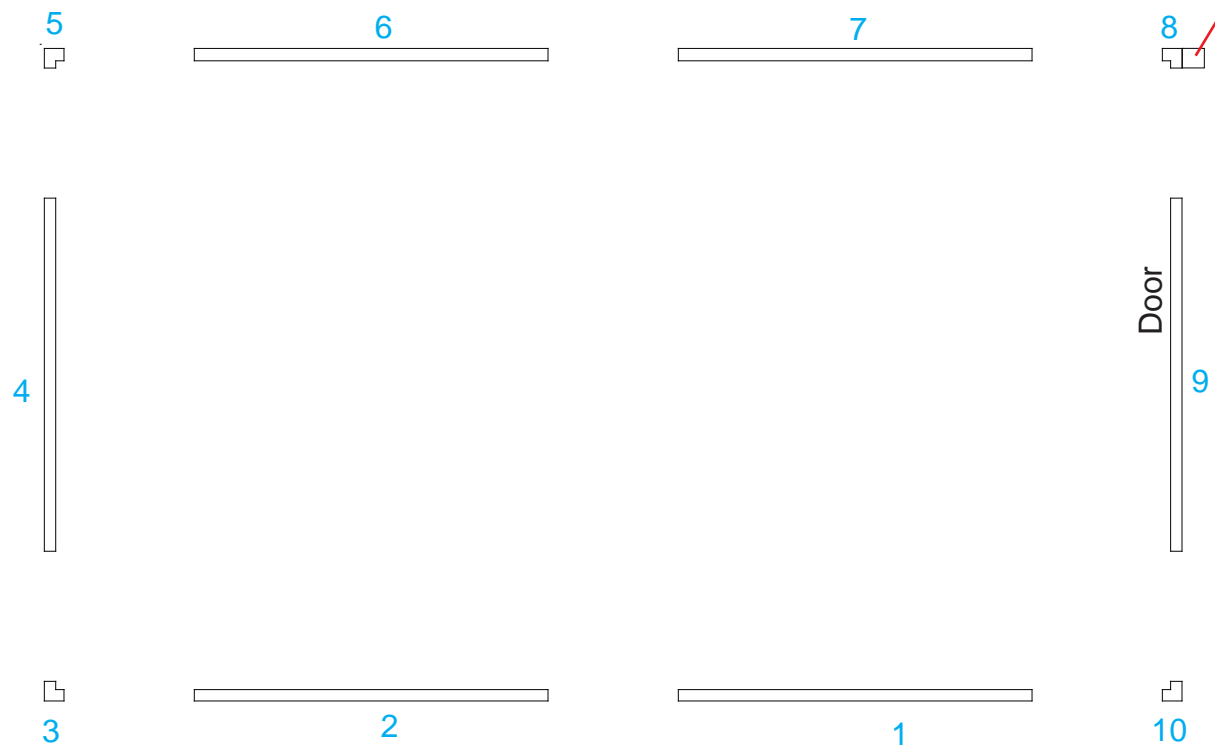

Square extrusion remain attached to 90° corner using pressure screws.
Do not disassemble

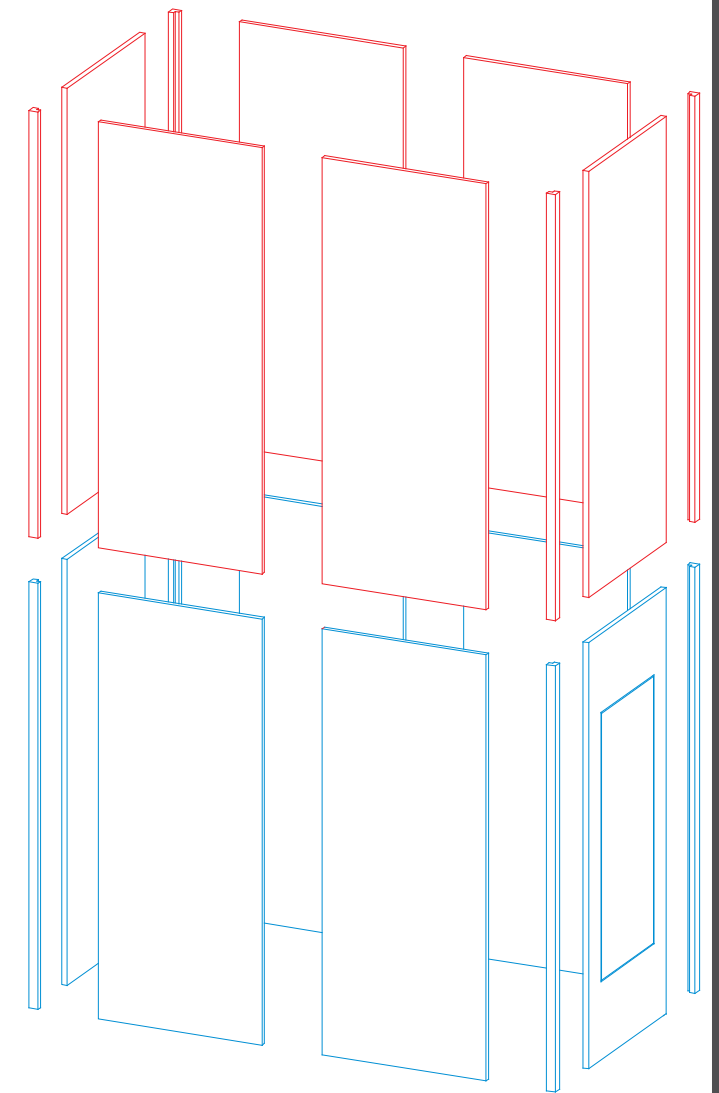

WHEN DISASSEMBLING ALUMINUM EXTRUSION, TIGHTEN ALL SETSCREWS AND LOCKS TO PREVENT LOSS DURING SHIPPING

Item Number	Description
1	19" w x 47.5" h Flat Panel
2	19" w x 47.5" h Flat Panel
3	47.5" h 90° Connector
4	19" w x 47.5" h Flat Panel
5	47.5" h 90° Connector
6	19" w x 47.5" h Flat Panel
7	19" w x 47.5" h Flat Panel
8	47.5" h 90° Connector
9	19" w x 47.5" h Flat Panel
10	47.5" h 90° Connector

Steps:

1) Connect panels together in numerical order.

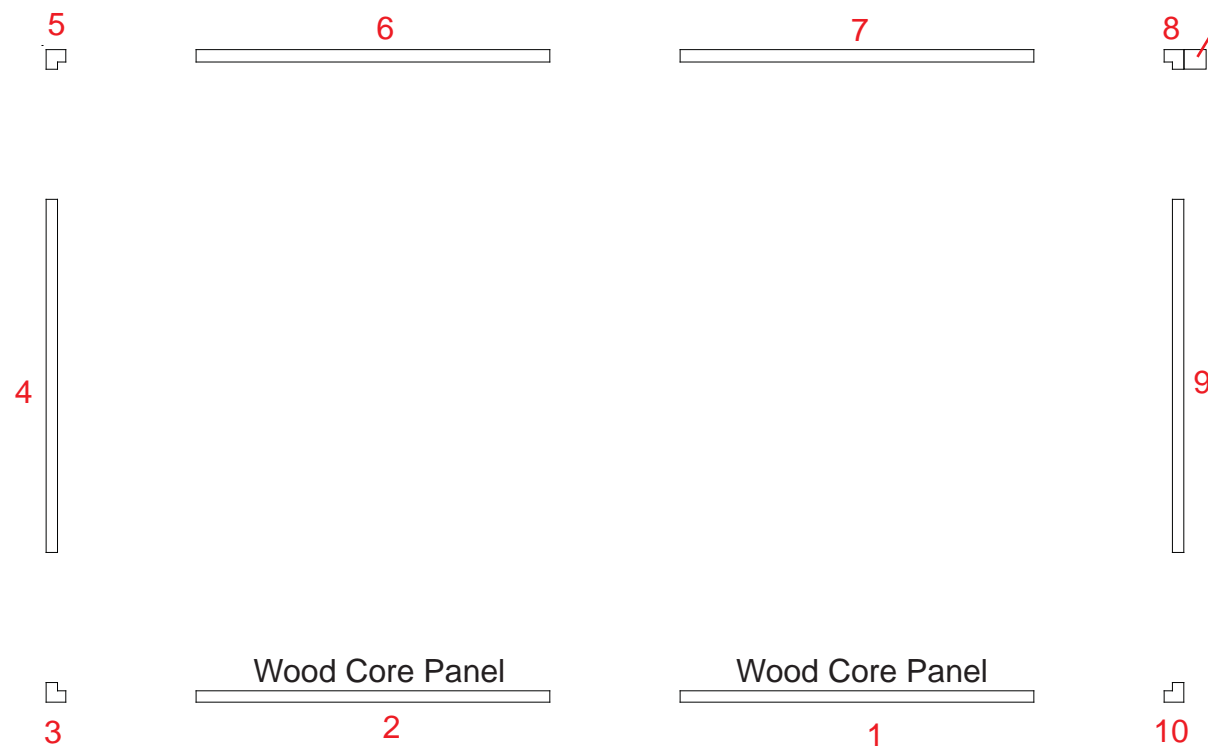

Square extrusion remain attached to 90° corner using pressure screws.
Do not disassemble

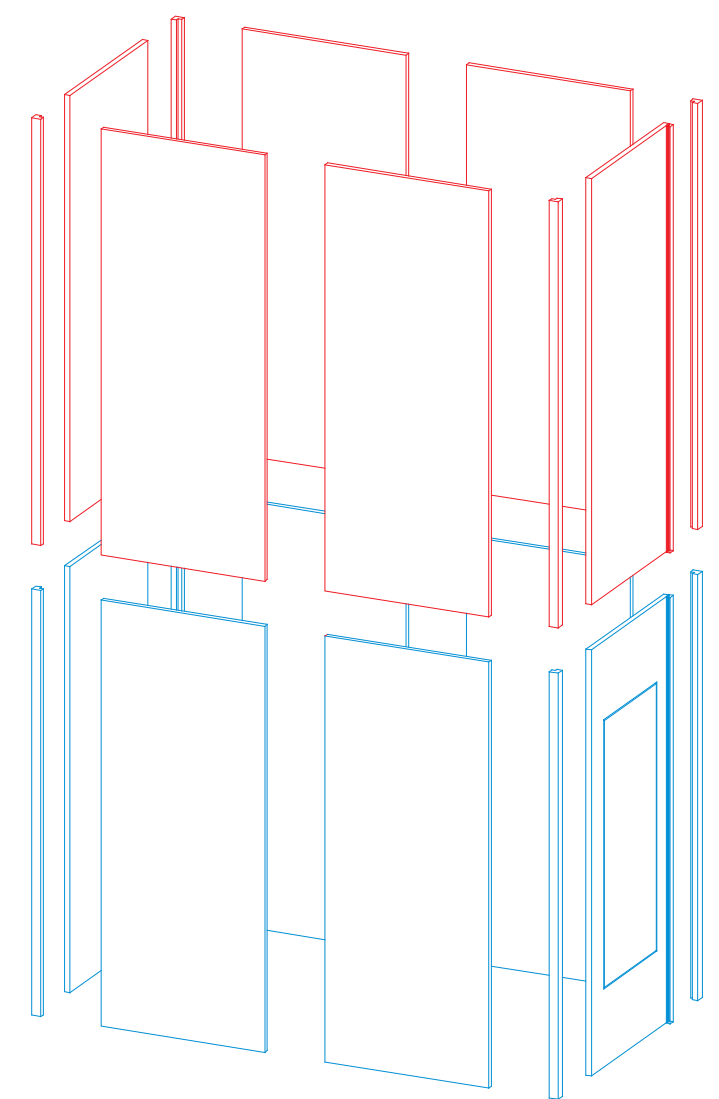

WHEN DISASSEMBLING ALUMINUM EXTRUSION, TIGHTEN ALL SETSCREWS AND LOCKS TO PREVENT LOSS DURING SHIPPING

Part Number	Qty	Description
1	2	48”h Lower Vertical Extrusion
2	2	48”h Upper Vertical Extrusion
3a/3c	3	33”w Horizontal Extrusion
3b/3d	3	33”w Horizontal Extrusion

Steps:

- 1) Connect extrusions together [1 to 2 and 3a to 3b].
- 2) Connect horizontal assemblies between vertical assemblies as shown.
- 3) Attach assembled frame to connector located on side of closet using pressure screws.

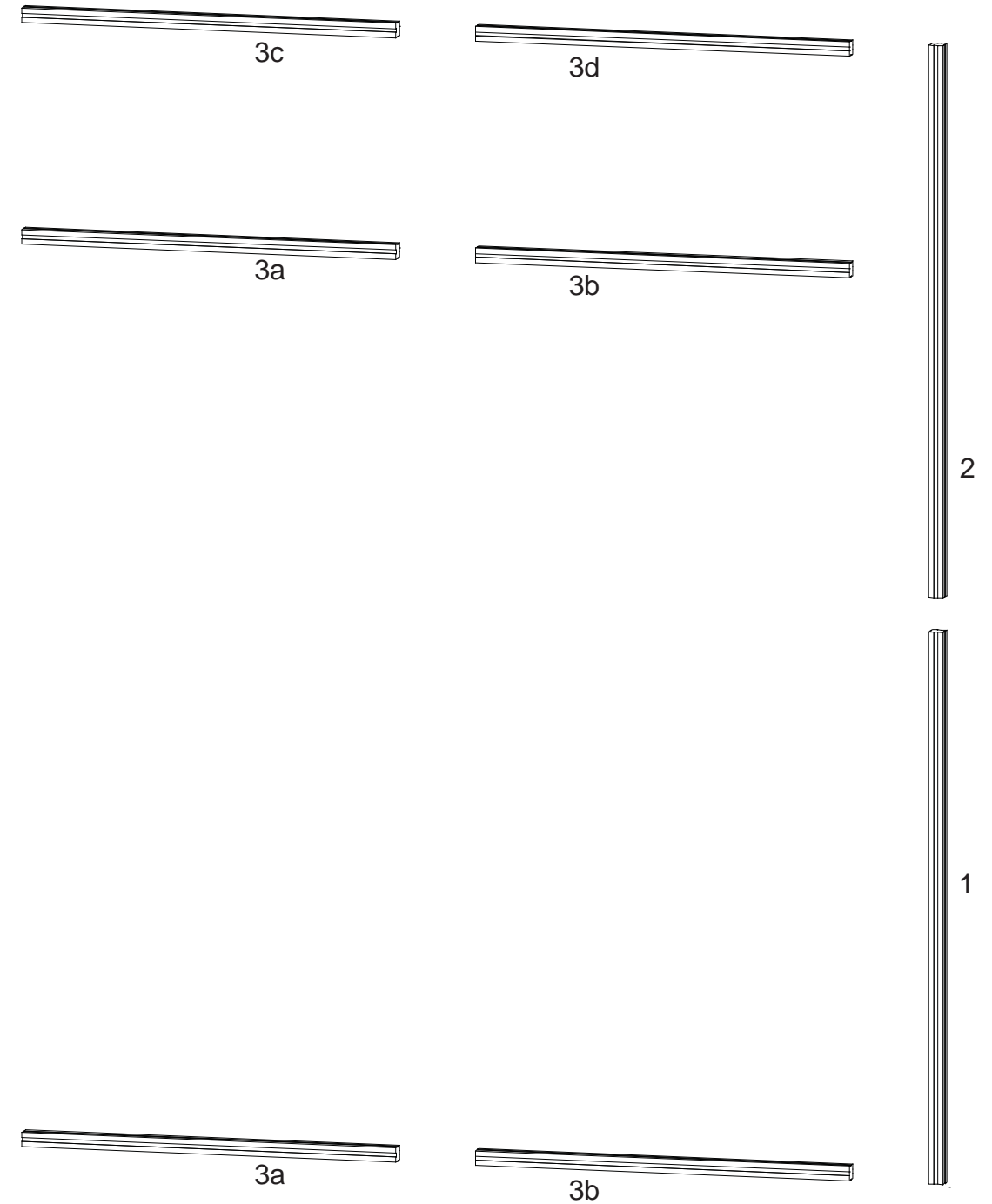
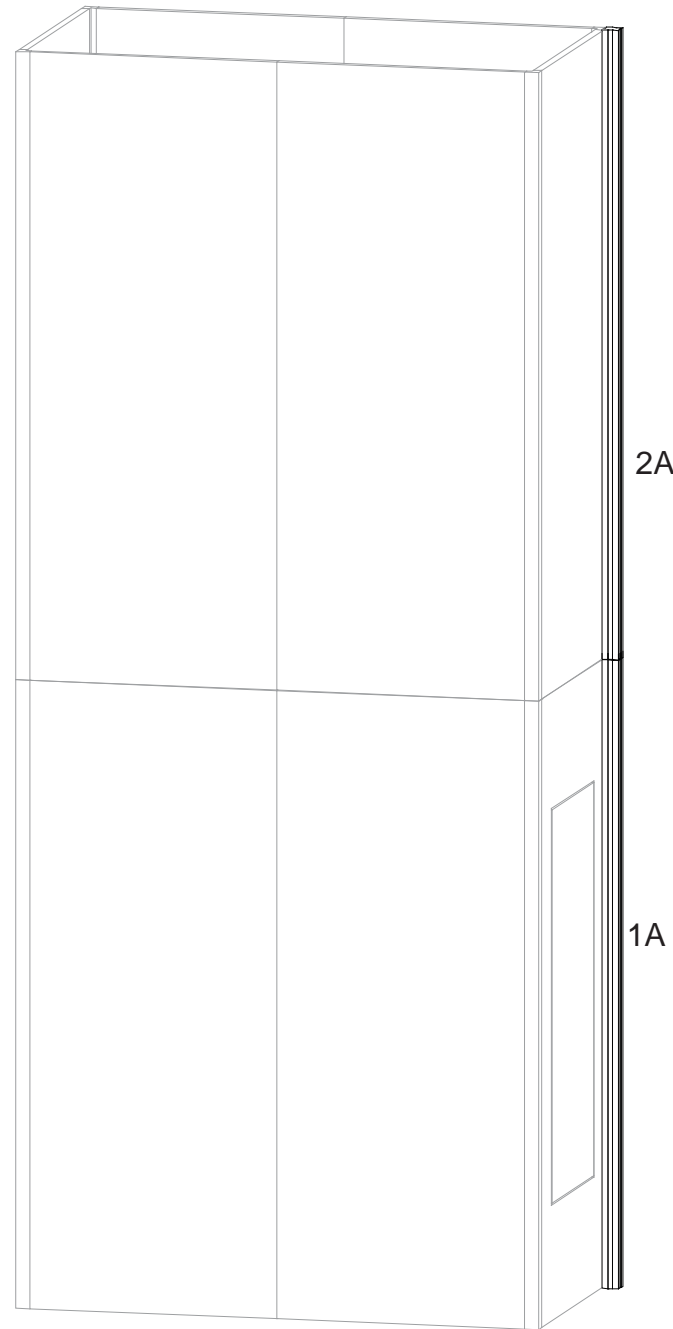
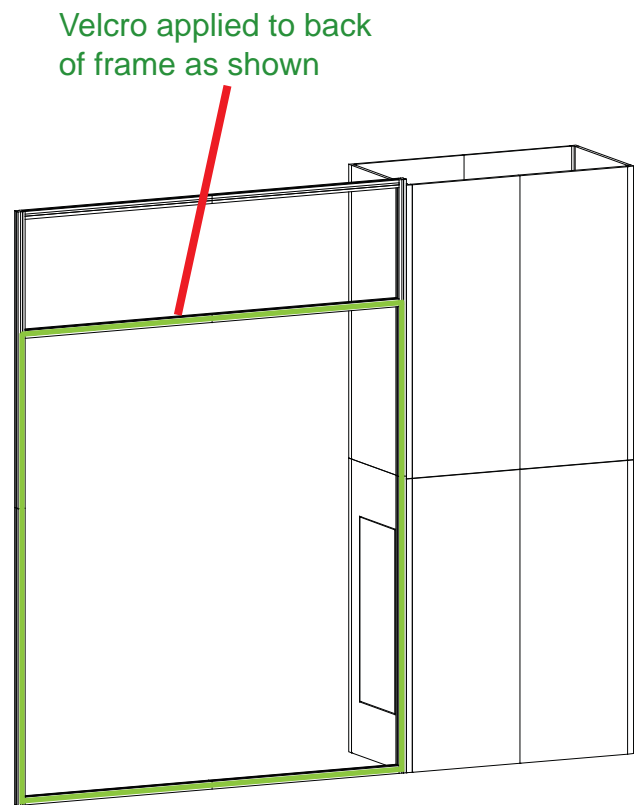

WHEN DISASSEMBLING ALUMINUM EXTRUSION, TIGHTEN ALL SETSCREWS AND LOCKS TO PREVENT LOSS DURING SHIPPING

Steps:

- 1) Attach lights on top of assembled frame where indicated.
- 2) Attach monitor mount to tower as shown.

Monitor Mount Attachment

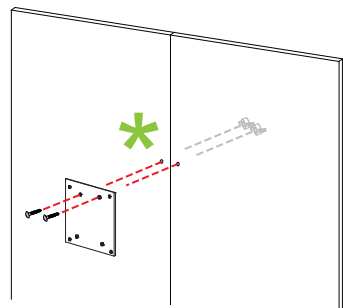

Attach back plate to panels where indicated using bolts and wingnuts. Then slide front plate over and secure in place.

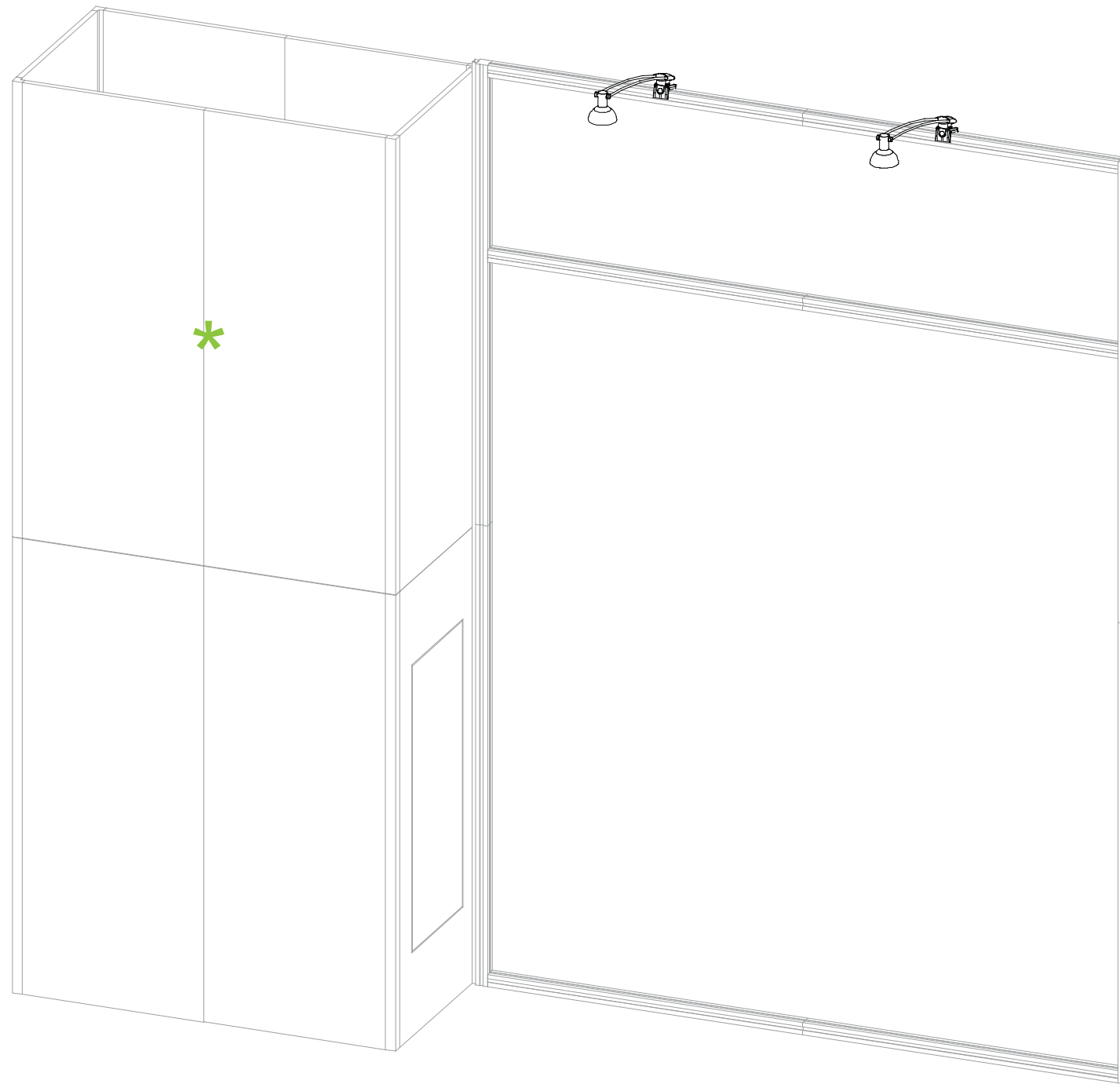

Light Connection

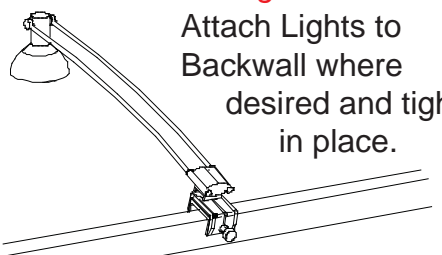

Attach Lights to Backwall where desired and tighten in place.



WHEN DISASSEMBLING ALUMINUM EXTRUSION, TIGHTEN ALL SETSCREWS AND LOCKS TO PREVENT LOSS DURING SHIPPING

Item Number	Description
11	19"w x 42"h Flat Panel
12	42"h 90° Corner Connector
13	19"w x 42"h Flat Panel
14	42"h 90° Corner Connector
15	19"w x 42"h Flat Panel w/ Door
16	42"h 90° Corner Connector
17	19"w x 42"h Flat Panel
18	42"h 90° Corner Connector

Steps:
Connect panels together in numerical order as shown in illustrations.

Place internal shelf atop shelf supports.

Set counter atop assembled pedestal.

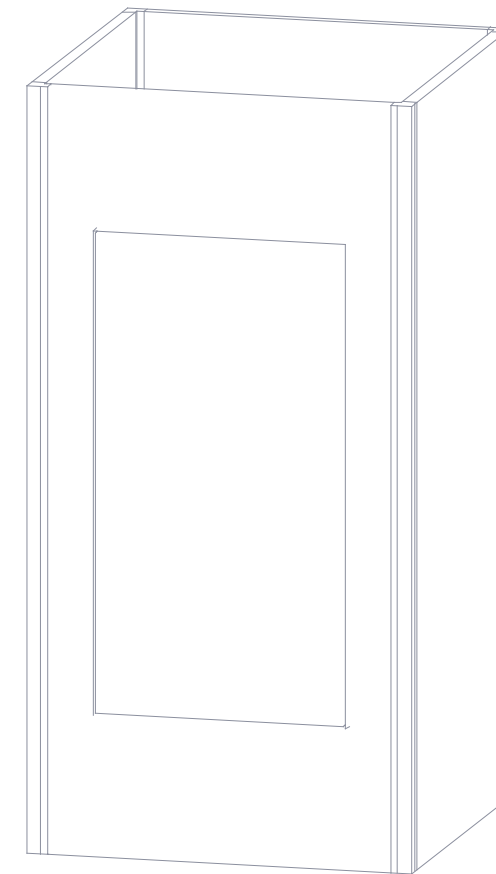
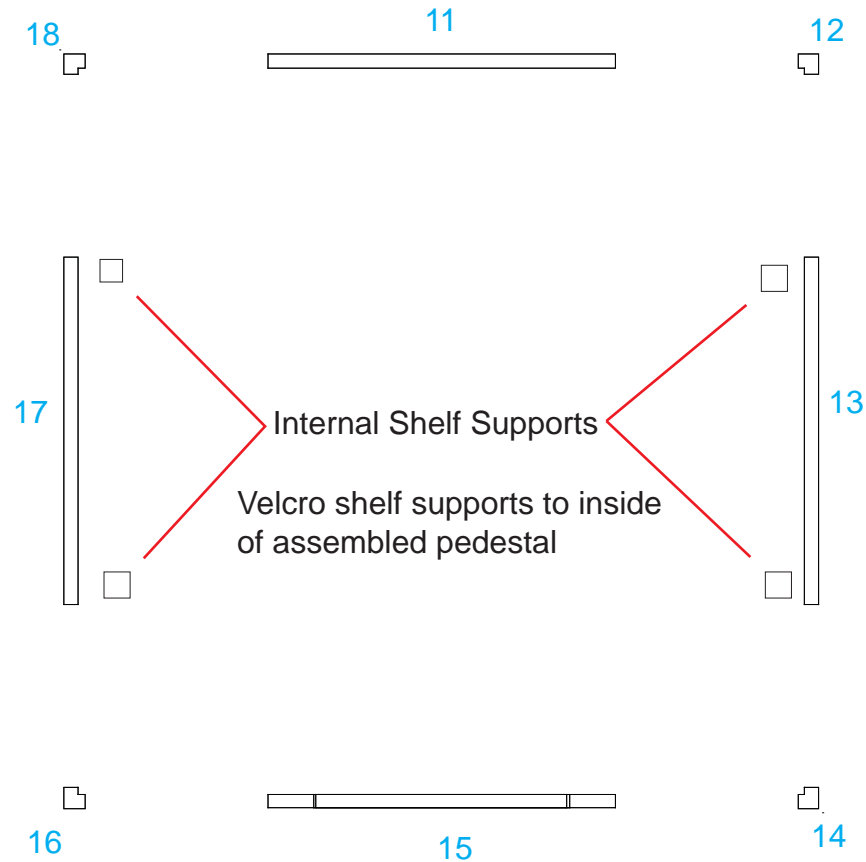
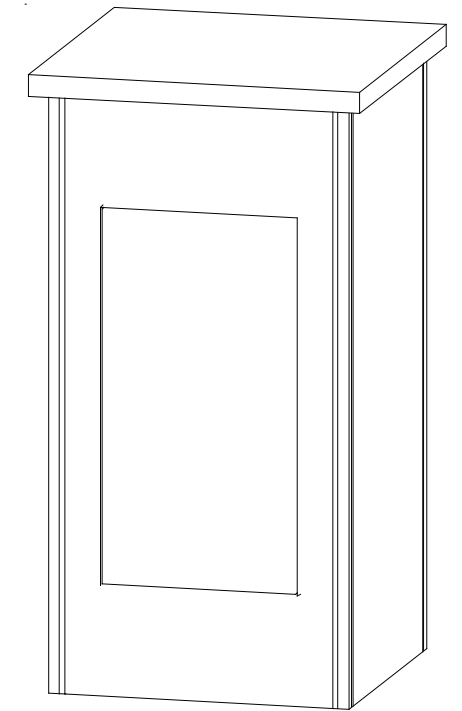
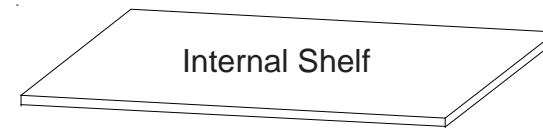

WHEN DISASSEMBLING ALUMINUM EXTRUSION, TIGHTEN ALL SETSCREWS AND LOCKS TO PREVENT LOSS DURING SHIPPING

Top View of each Level

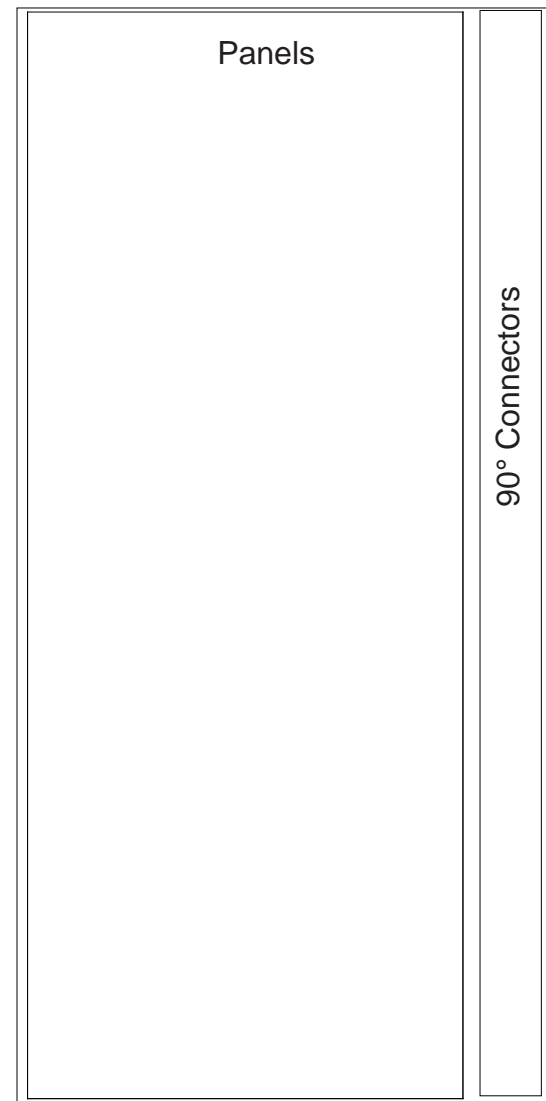

Level 1 (Bottom)

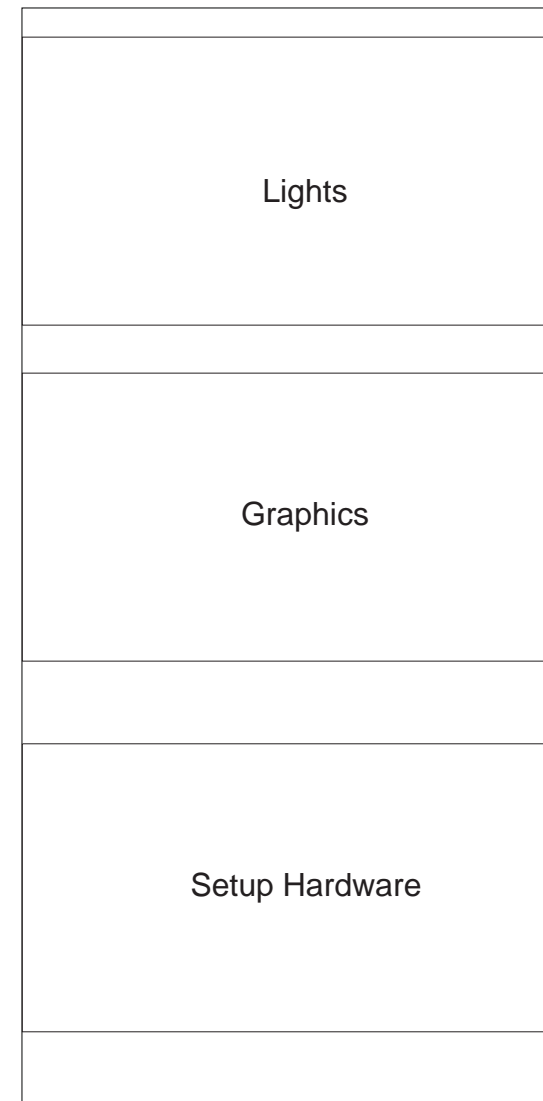

Slip Sheet Level 2



WHEN DISASSEMBLING ALUMINUM EXTRUSION, TIGHTEN ALL SETSCREWS AND LOCKS TO PREVENT LOSS DURING SHIPPING

Top View of each Level

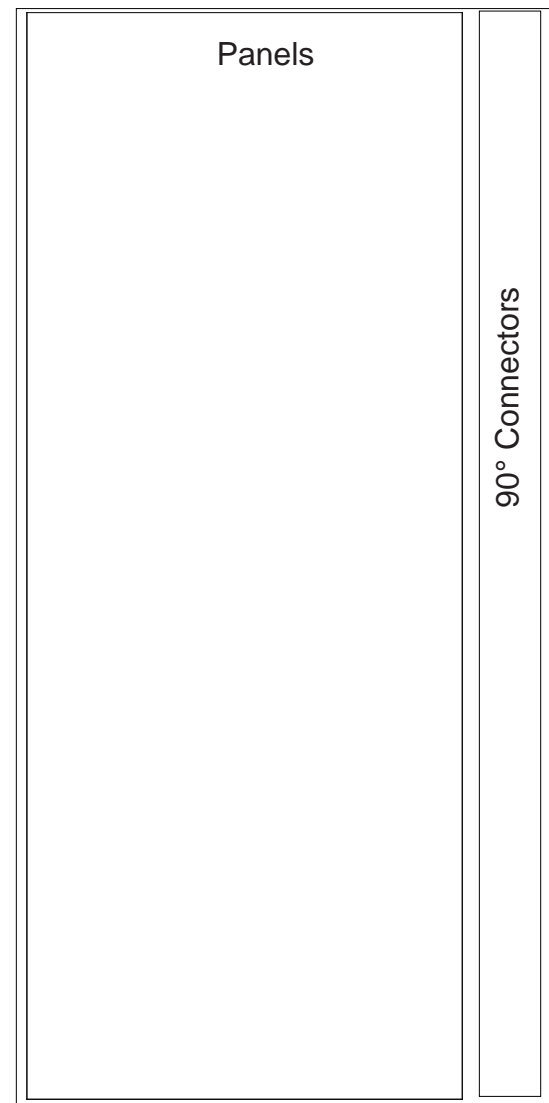

Level 1 (Bottom)

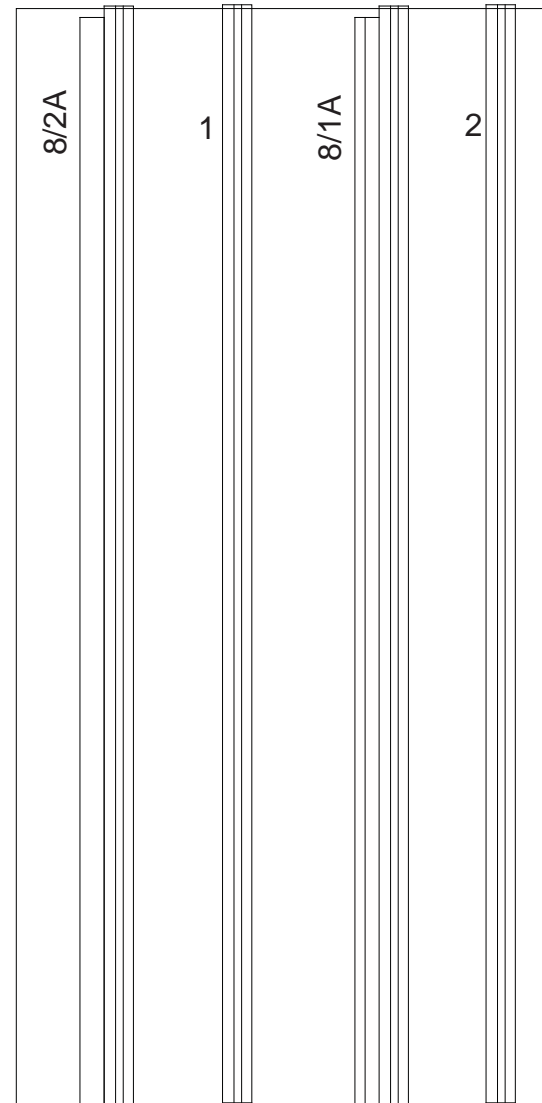

Level 2

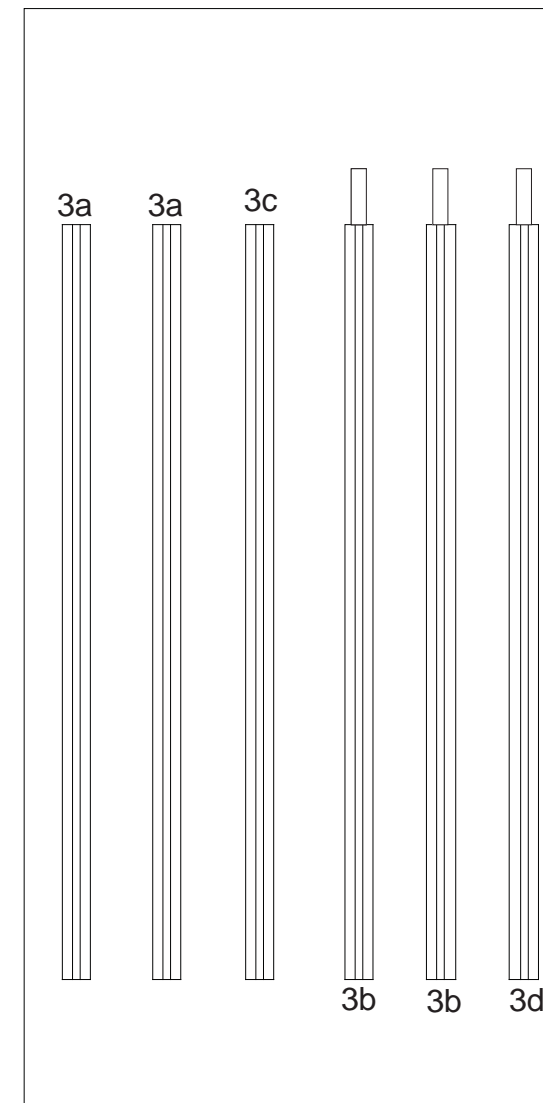

Level 3



WHEN DISASSEMBLING ALUMINUM EXTRUSION, TIGHTEN ALL SETSCREWS AND LOCKS TO PREVENT LOSS DURING SHIPPING

Top View of each Level

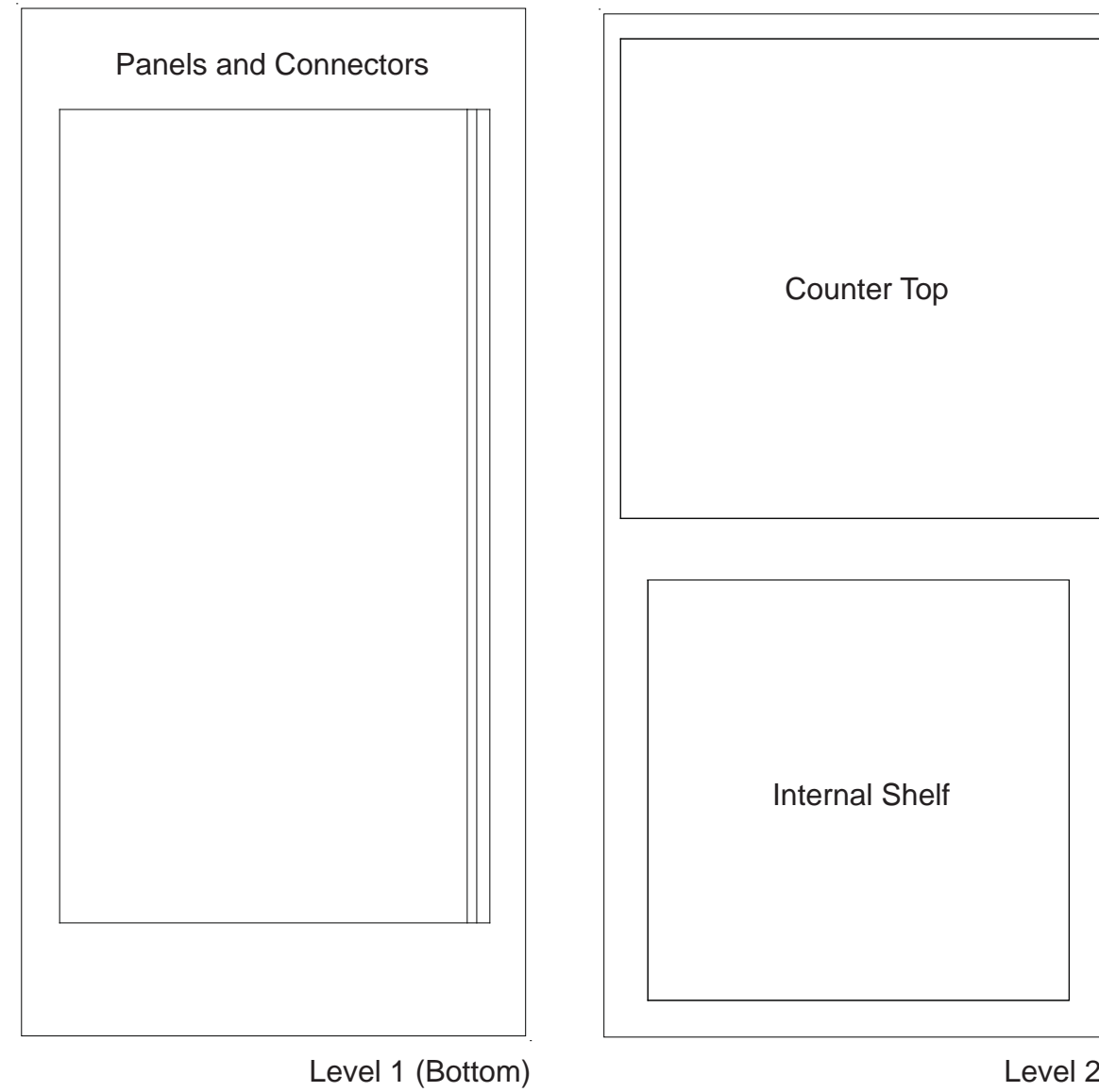

WHEN DISASSEMBLING ALUMINUM EXTRUSION, TIGHTEN ALL SETSCREWS AND LOCKS TO PREVENT LOSS DURING SHIPPING