

| Part Number | Description                 |
|-------------|-----------------------------|
| 9           | 40" h Round Vertical        |
| 10          | 40" h Round Vertical        |
| 11          | 30" h Round Vertical        |
| 12          | 25.241" w Extrusion         |
| 13          | 26.417" w Extrusion         |
| 14          | 26.417" w Extrusion         |
| 15          | 14.0564" w Curved Extrusion |
| 16          | 20.7107" w Curved Extrusion |
| 17          | 5" w Extrusion              |
| 18          | 3" w Extrusion              |

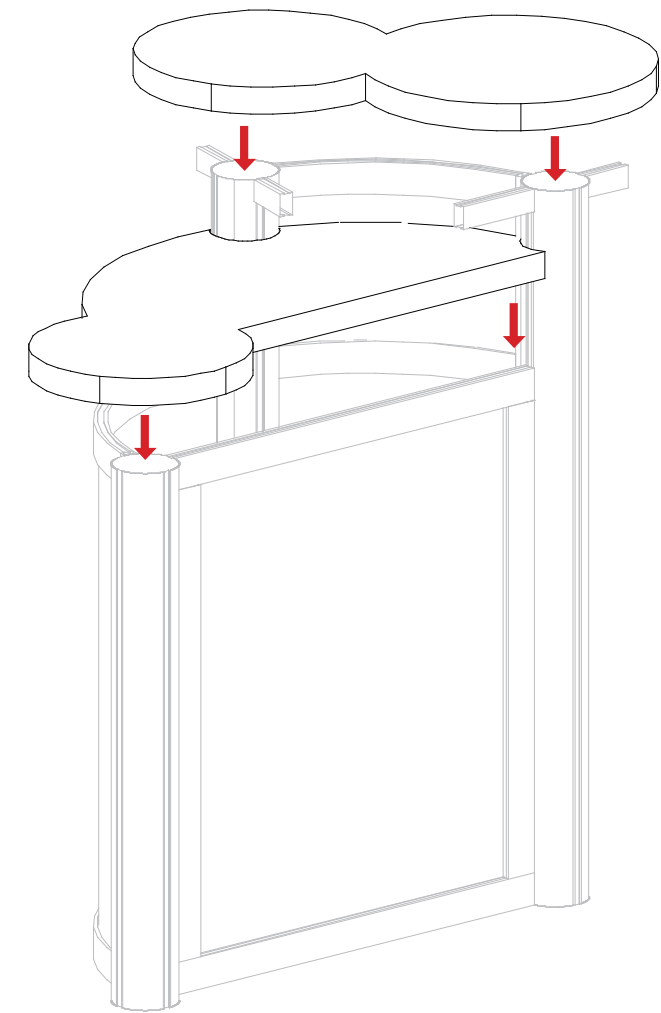

Steps:

- 1) Connect lower horizontal extrusions [12, 15, and 16] between vertical extrusions [9, 10 and 11] as shown.
- 2) Attach vertical extrusions [13 and 14] to the top groove of [12] at the far left and right as shown.
- 3) Place lower inserts and door as shown.
- 4) Connect upper horizontal extrusions [12, 15, and 16] between vertical extrusions [9, 10 and 11], atop inserts and door as shown.
- 5) Place last small insert atop extrusion as shown and connect 3rd upper extrusion [15] atop insert.
- 6) Attach small extrusions [17, 17A and 18] as shown for counter support.
- 7) Place counters atop base and supports as shown.

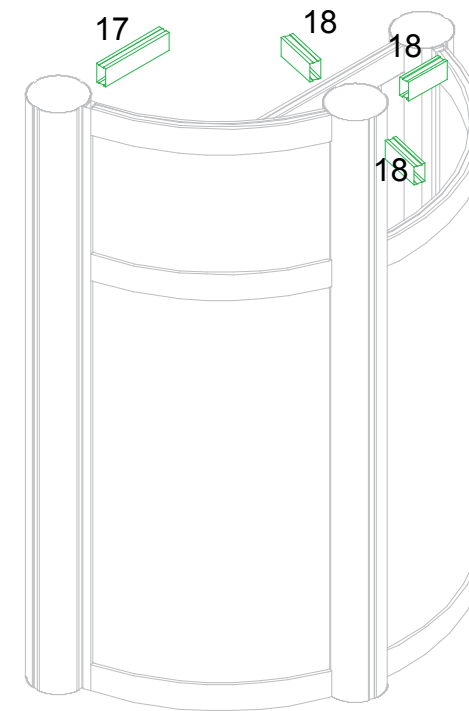
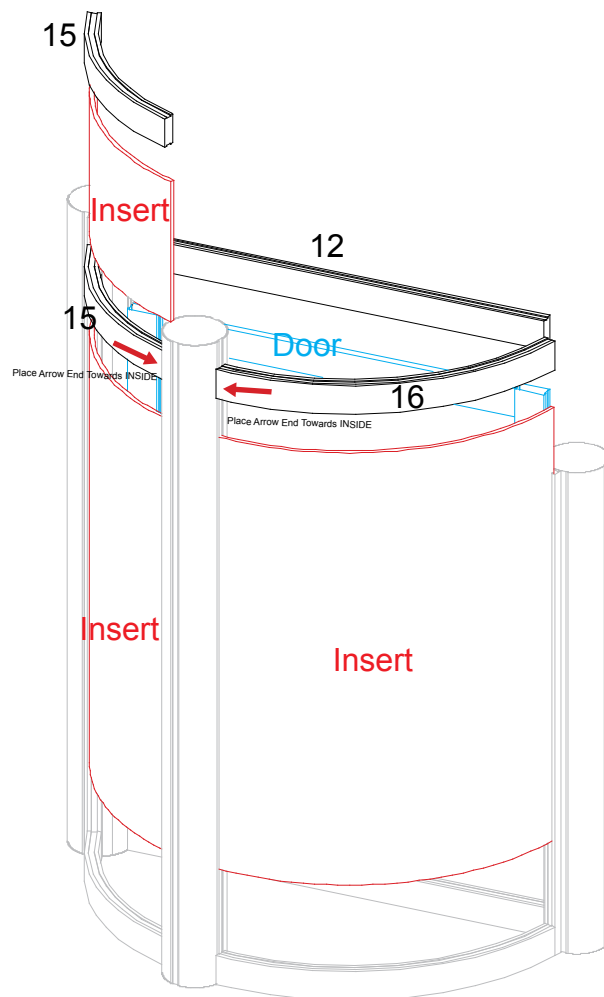
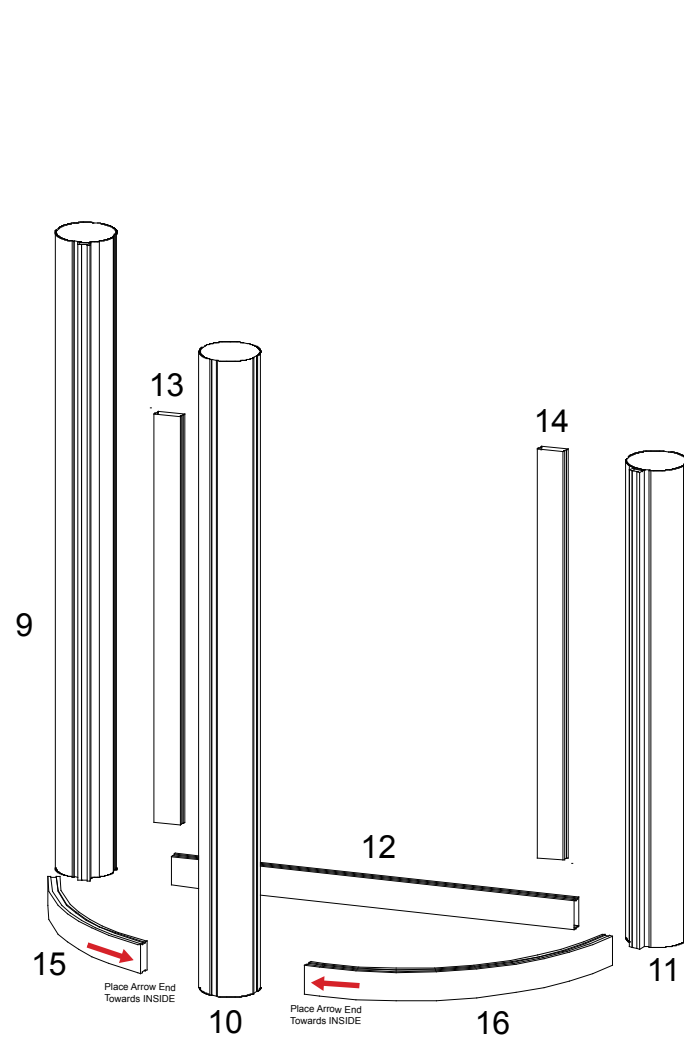
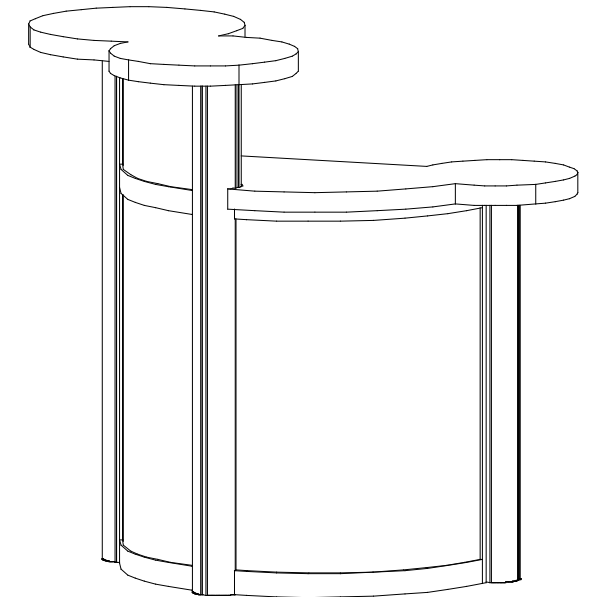

**WHEN DISASSEMBLING ALUMINUM EXTRUSION, TIGHTEN ALL SETSCREWS AND LOCKS TO PREVENT LOSS DURING SHIPPING**

# visionary™ IDESIGNS

## Using Your Setup Instructions

The Visionary Designs Setup Instructions are created specifically for your configuration. They are laid out sequentially, including an exploded view of the entire display, and then a logical series of detailed steps to assemble the main structure and components. We encourage you to study the instructions **before** attempting to assemble your exhibit.

Each page reminds you to tighten the setscrews after disassembling your exhibit to prevent loss of the locks and setscrews (see below in RED). This is **VERY IMPORTANT**.

## Cleaning and Packing Your Display

- 1) Use care when cleaning aluminum extrusion or acrylic inserts. Use only non-abrasive cleaners.
- 2) When cleaning laminate inserts or countertops, use mild cleansers and a soft material such as cotton.
- 3) Keep all display components away from extreme heat and long exposure to sunlight to avoid warping and fading.
- 4) Retain all packing material. It will make re-packing much easier and will reduce the likelihood of shipping damage.



**The Tool**

Most Visionary Designs exhibits can be assembled with the supplied Hex Key Tool. Occasionally, a flat head screwdriver may be required.



Detail A

**Typical Connection**



**Typical Connection (cont'd)**

Most horizontal extrusion connections have a patented expandable lock. This lock inserts into the groove of an opposing extrusion. Tightening the lock with the Hex Key Tool expands the lock and creates a strong positive connection.



Detail B

**Numbered Label**

Each extrusion contains a numbered label which corresponds with setup instructions. The label is located within a groove of the extrusion (when possible). With Visionary Designs the labels contain Black numbers unless otherwise specified.



Detail C

**Horizontal Inline Connection** (remove only one setscrew)

Remove only (1) setscrew when disassembling. Replace setscrew in extrusion after assembling it. Before packing, replace setscrew in extrusion to avoid losing it.



Detail D

**Base Plate Connection**

Attach base plate to round or square vertical extrusion using the bolt provided. Be careful not to strip the threads.



Detail E

**Vertical Connection**  
(remove only two setscrews)

When vertical extrusions are packed in portable cases rather than crates or tubs, they must be broken down into smaller sections which then require assembly.

Remove only (2) setscrews when disassembling. Replace setscrews in extrusion after assembling it. Before packing, replace setscrews in extrusion to avoid losing them.

**WHEN DISASSEMBLING ALUMINUM EXTRUSION, TIGHTEN ALL SETSCREWS AND LOCKS TO PREVENT LOSS DURING SHIPPING**

866.652.2100

| Part Number | Qty | Description                     |
|-------------|-----|---------------------------------|
| 1           | 1   | 38" h Vertical Extrusion        |
| 2           | 1   | 38" h Vertical Extrusion        |
| 3           | 1   | 38" h Vertical Extrusion        |
| 4           | 1   | 38" h Vertical Extrusion        |
| 5/5A        | 2/2 | 22.9097" w Curved Extrusion     |
| 6           | 4   | 16.3943" w Curved Extrusion     |
| 7           | 1   | 35" w Square Vertical Extrusion |
| 8           | 1   | 35" w Square Vertical Extrusion |

Steps:

- 1) Connect lower horizontal extrusions [5, 5A and 6] between vertical extrusions [1, 2, 3 and 4] as shown.
- 2) Place inserts and door as shown.
- 3) Connect upper horizontal extrusions [5, 5A and 6] between vertical extrusions [1, 2, 3 and 4], atop inserts and door as shown.
- 4) Connect vertical extrusion [7 to 8] then connect to base using standoff caps as shown.
- 5) Place counters atop base as shown attaching plex top using standoff barrels and caps.
- 6) Attach monitor mount as shown.

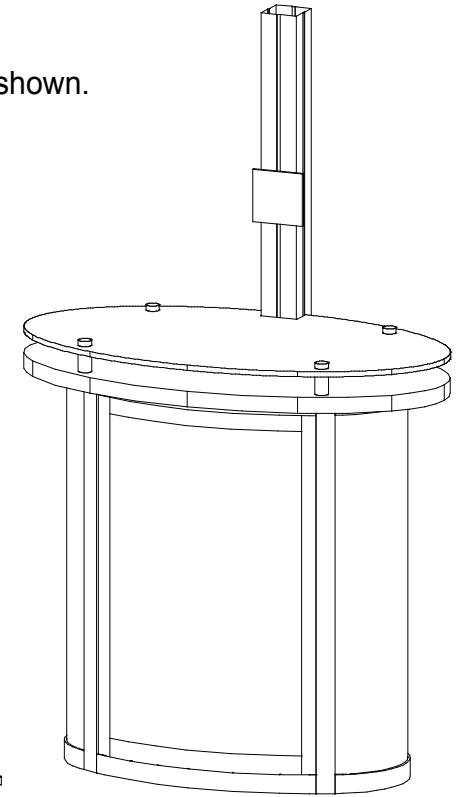
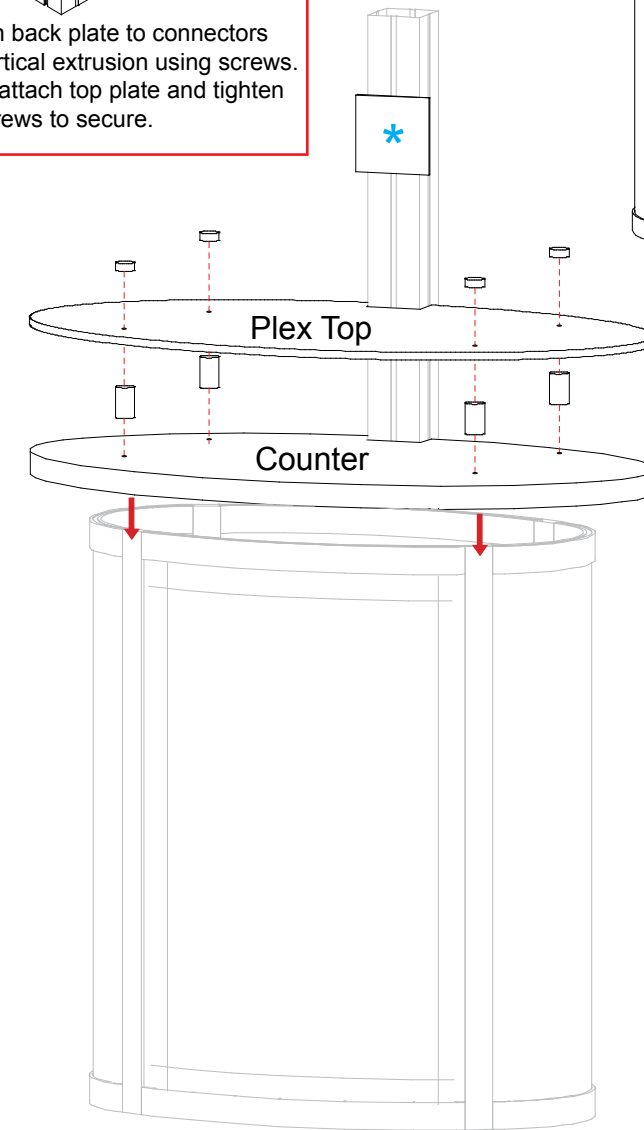
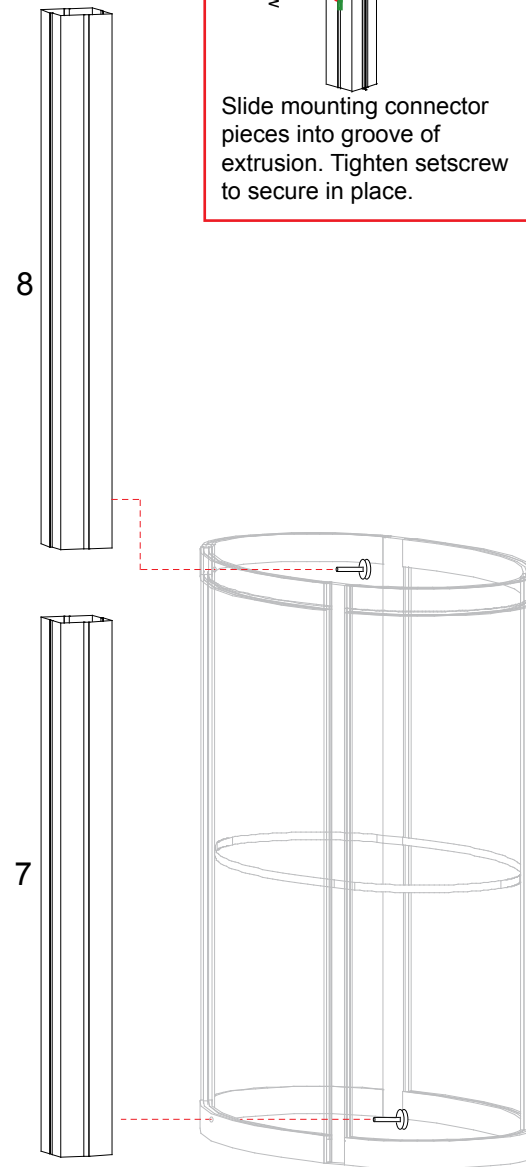
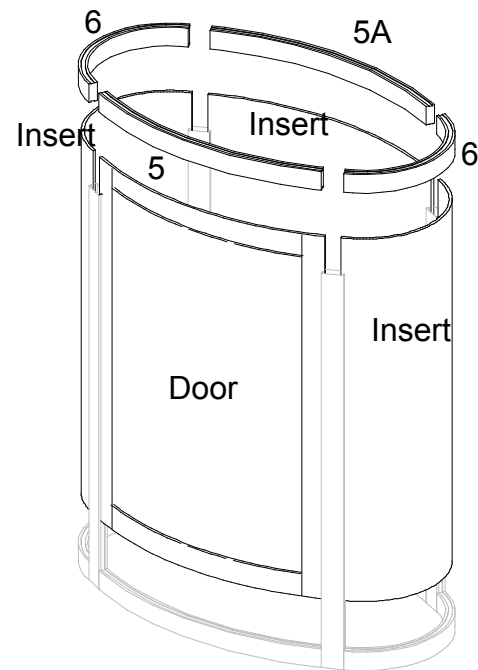
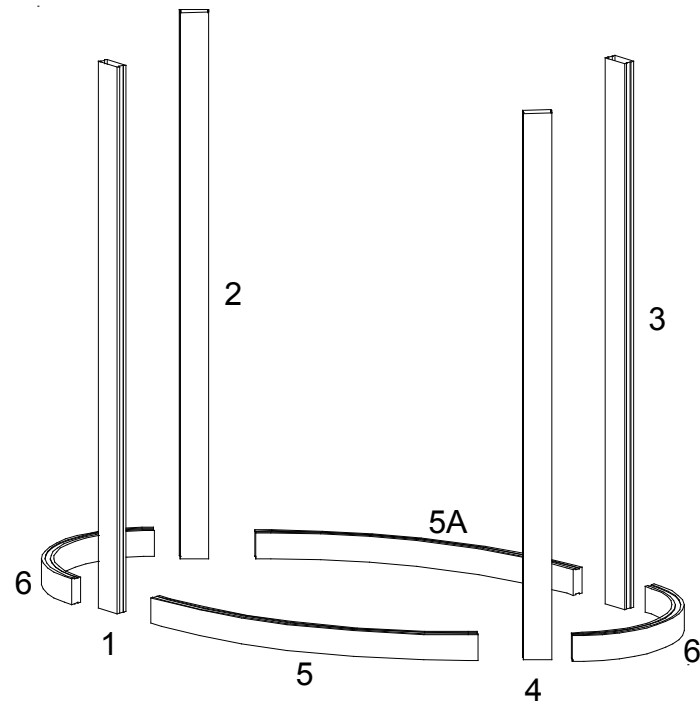
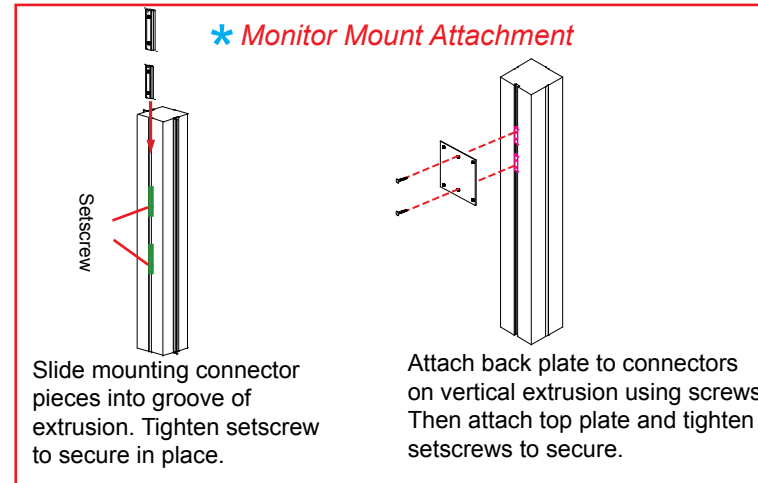

**WHEN DISASSEMBLING ALUMINUM EXTRUSION, TIGHTEN ALL SETSCREWS AND LOCKS TO PREVENT LOSS DURING SHIPPING**

2 Tier Counter Packaging

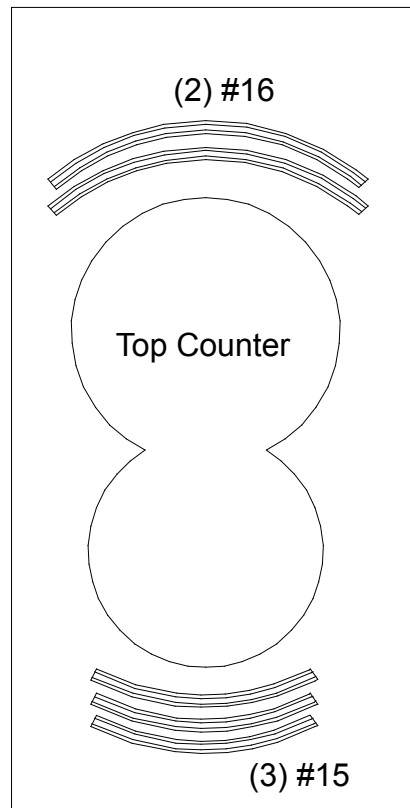

Level 1  
(At bottom)

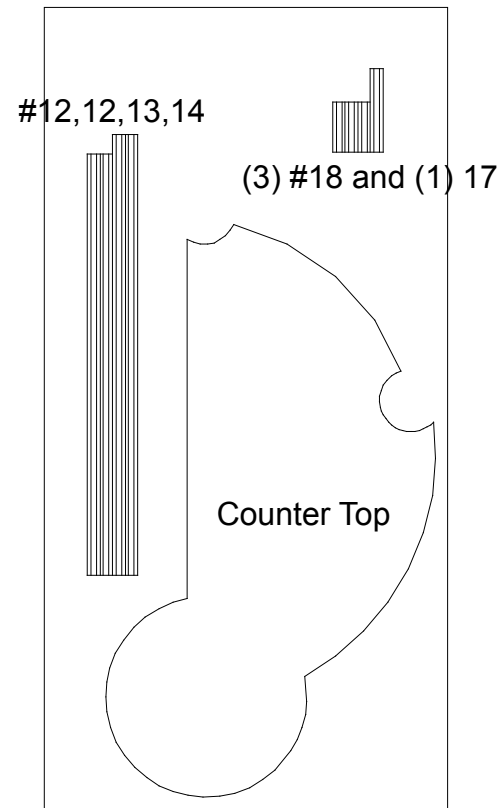

Level 2

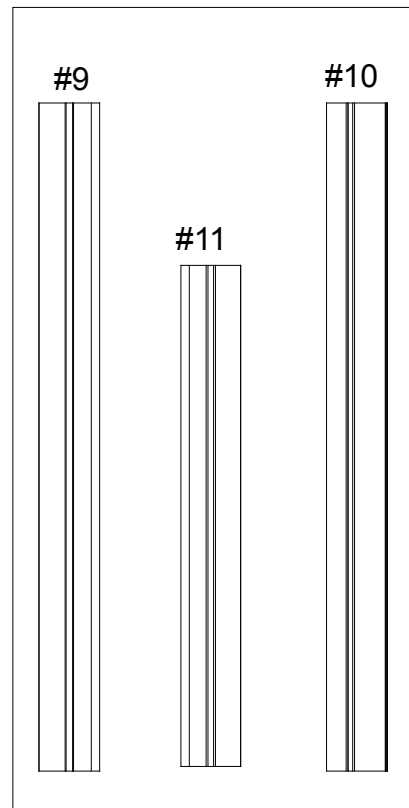

Level 3

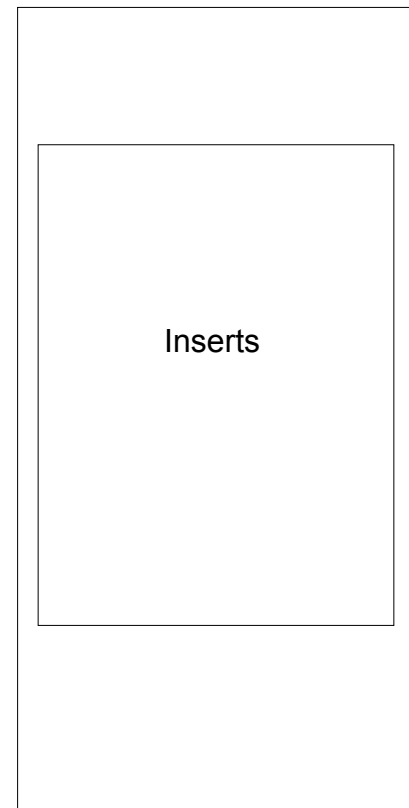

Level 4

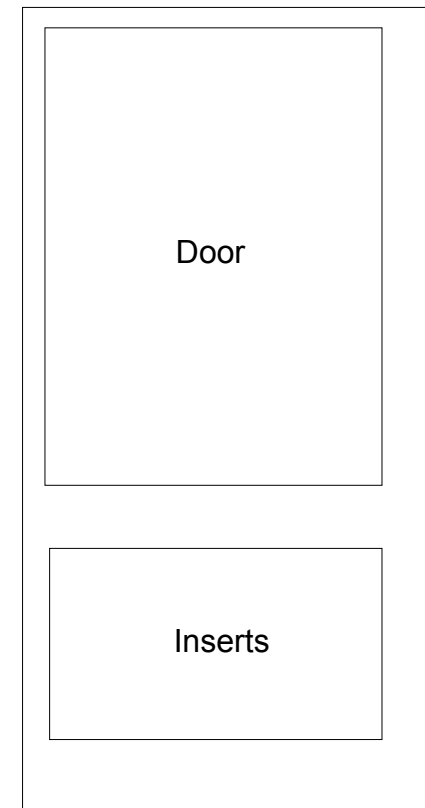

Level 5

WHEN DISASSEMBLING ALUMINUM EXTRUSION, TIGHTEN ALL SETSCREWS AND LOCKS TO PREVENT LOSS DURING SHIPPING

Ellipse Counter Packaging

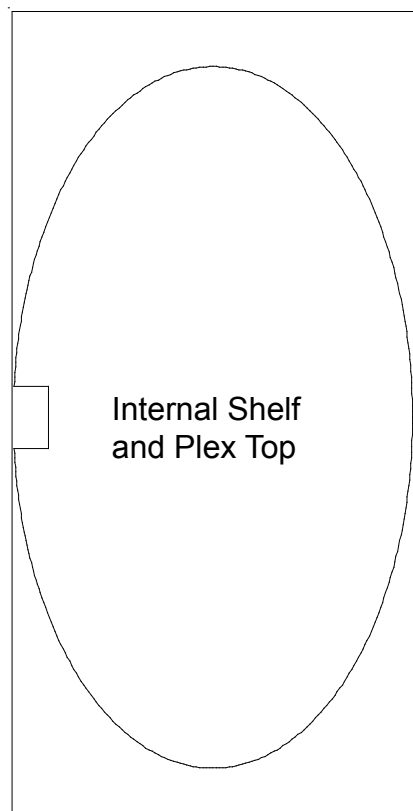

Level 1  
(At bottom)

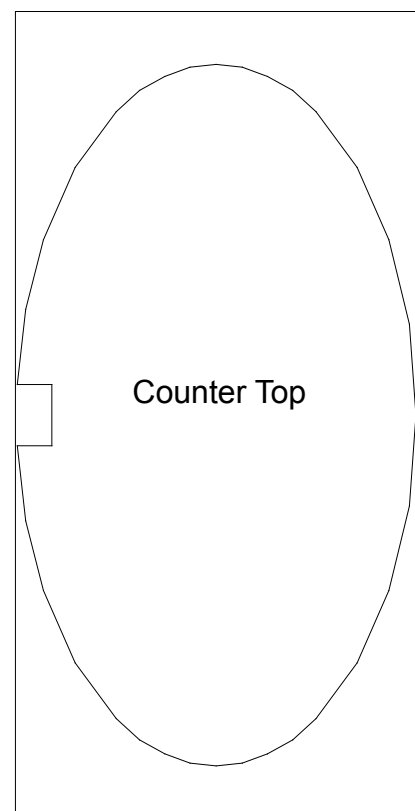

Level 2

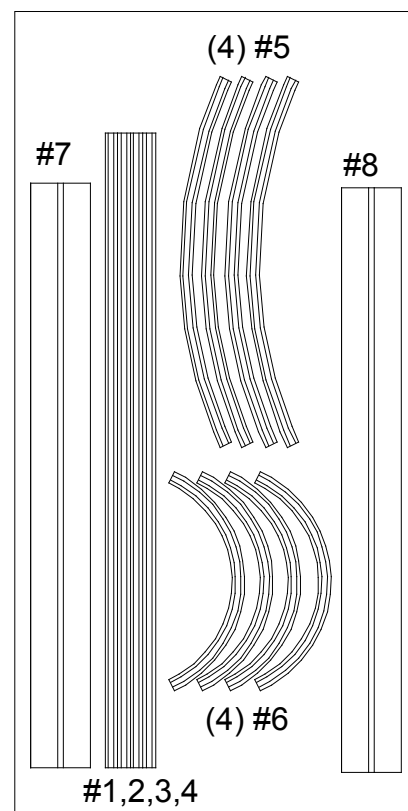

Level 3

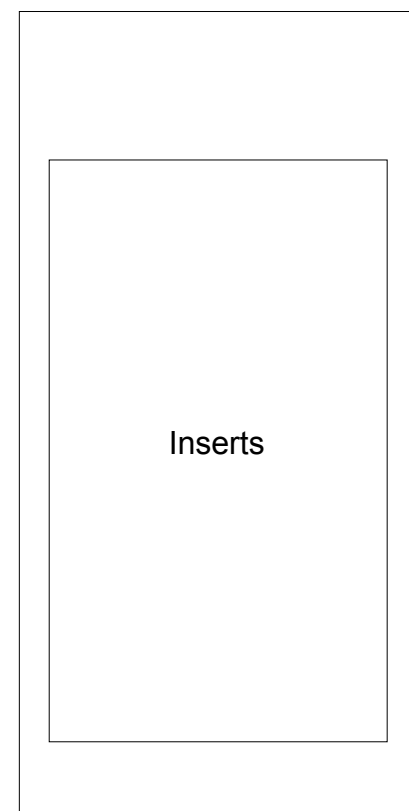

Level 4

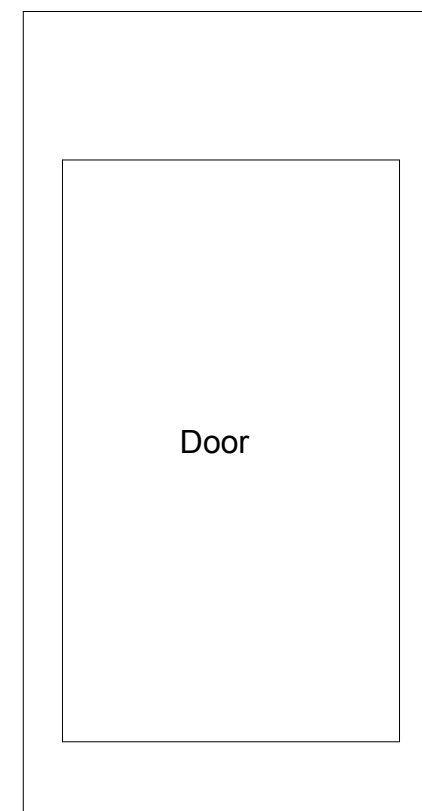

Level 5

WHEN DISASSEMBLING ALUMINUM EXTRUSION, TIGHTEN ALL SETSCREWS AND LOCKS TO PREVENT LOSS DURING SHIPPING