

WHEN DISASSEMBLING ALUMINUM EXTRUSION, TIGHTEN ALL SETSCREWS AND LOCKS TO PREVENT LOSS DURING SHIPPING

visionary™ IDESIGNS

Using Your Setup Instructions

The Visionary Designs Setup Instructions are created specifically for your configuration. They are laid out sequentially, including an exploded view of the entire display, and then a logical series of detailed steps to assemble the main structure and components. We encourage you to study the instructions **before** attempting to assemble your exhibit.

Each page reminds you to tighten the setscrews after disassembling your exhibit to prevent loss of the locks and setscrews (see below in RED). This is **VERY IMPORTANT**.

Cleaning and Packing Your Display

- 1) Use care when cleaning aluminum extrusion or acrylic inserts. Use only non-abrasive cleaners.
- 2) When cleaning laminate inserts or countertops, use mild cleansers and a soft material such as cotton.
- 3) Keep all display components away from extreme heat and long exposure to sunlight to avoid warping and fading.
- 4) Retain all packing material. It will make re-packing much easier and will reduce the likelihood of shipping damage.



The Tool

Most Visionary Designs exhibits can be assembled with the supplied Hex Key Tool. Occasionally, a flat head screwdriver may be required.



Typical Connection

Most horizontal extrusion connections have a patented expandable lock. This lock inserts into the groove of an opposing extrusion. Tightening the lock with the Hex Key Tool expands the lock and creates a strong positive connection.



Typical Connection (cont'd)



Numbered Label

Each extrusion contains a numbered label which corresponds with setup instructions. The label is located within a groove of the extrusion (when possible). With Visionary Designs the labels contain Black numbers unless otherwise specified.



Horizontal Inline Connection (remove only one setscrew)

Remove only (1) setscrew when disassembling. Replace setscrew in extrusion after assembling it. Before packing, replace setscrew in extrusion to avoid losing it.

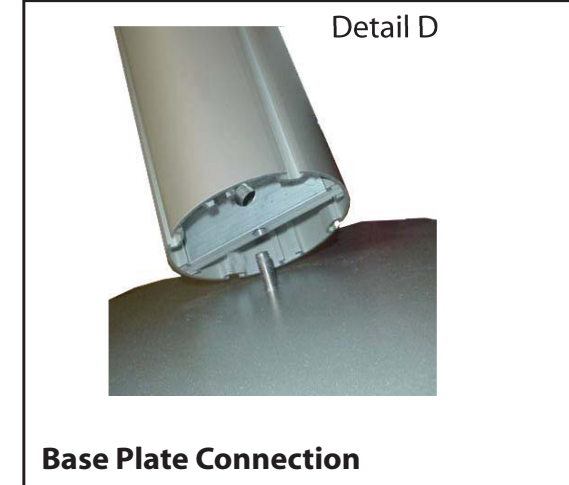

Base Plate Connection

Attach base plate to round or square vertical extrusion using the bolt provided. Be careful not to strip the threads.

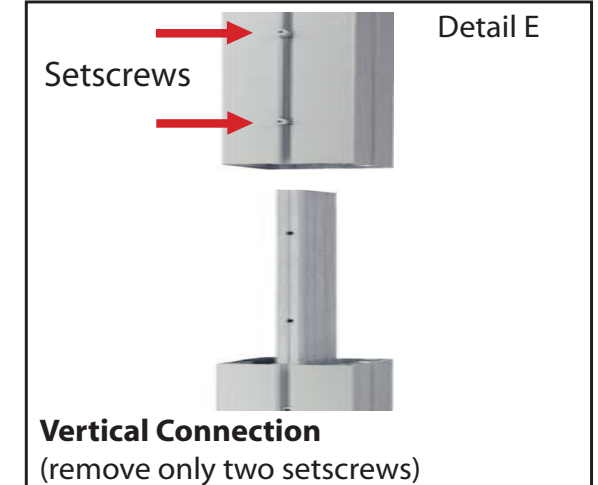

Vertical Connection
(remove only two setscrews)

When vertical extrusions are packed in portable cases rather than crates or tubs, they must be broken down into smaller sections which then require assembly.

Remove only (2) setscrews when disassembling. Replace setscrews in extrusion after assembling it. Before packing, replace setscrews in extrusion to avoid losing them.

WHEN DISASSEMBLING ALUMINUM EXTRUSION, TIGHTEN ALL SETSCREWS AND LOCKS TO PREVENT LOSS DURING SHIPPING

866.652.2100

Item	Qty.	Description
1	1	Oval Base Plates
2	1	84" h Vertical Extrusion w/ Canopy Attachment
3	1	84" h Vertical Extrusion
4	1	83.75" h Vertical Extrusion w/ Canopy Attachment
5A/5B	1/1	28" Horizontal Extrusion
6A/6B	1/1	52" Horizontal Extrusion

Steps

- 1) Attach Vertical extrusion [4] to the Oval base plate [1].
- 2) Attach Horizontal extrusions [6A and 6B] between assembled section [2, 3, 5A and 5B] and vertical extrusion [4] as shown.

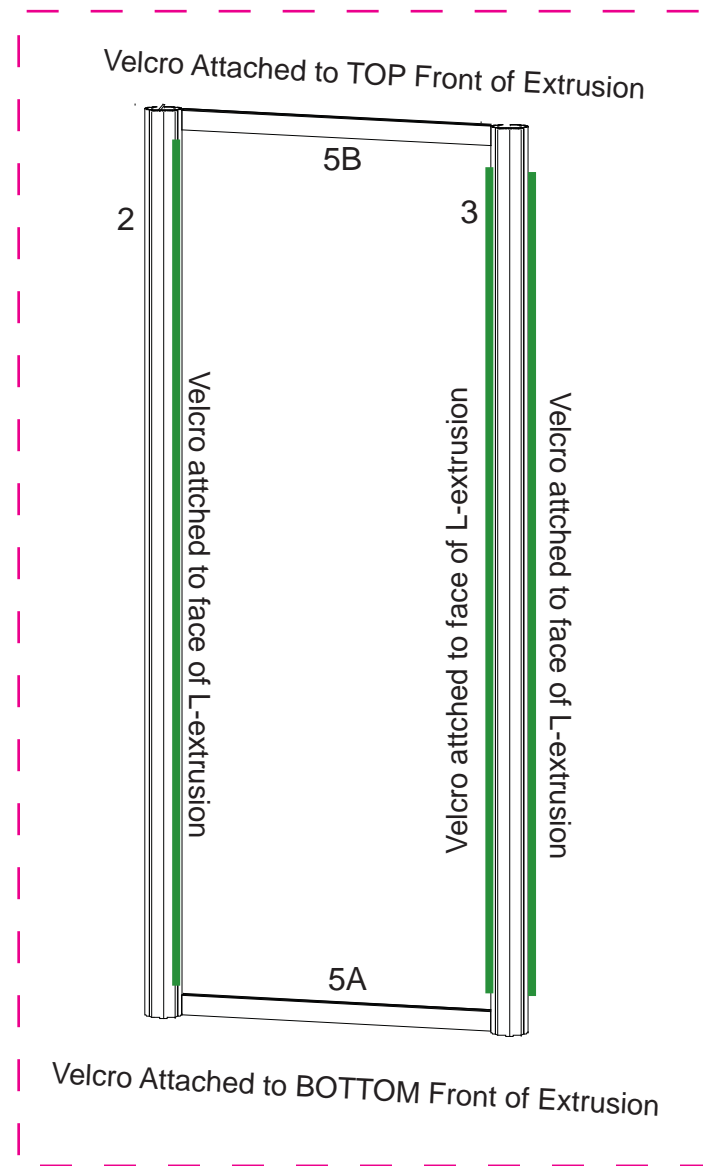
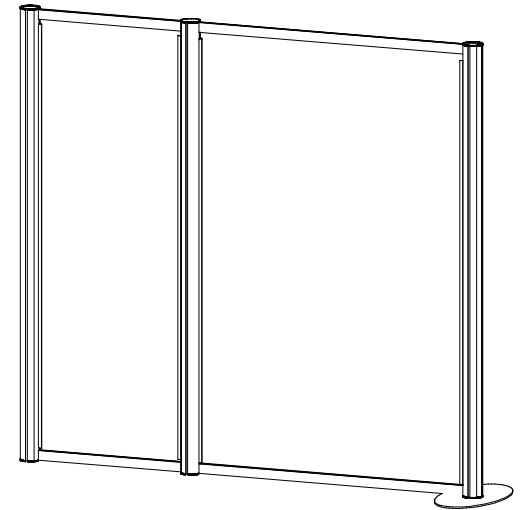

**** This section must stay assembled when shipping in custom crate**

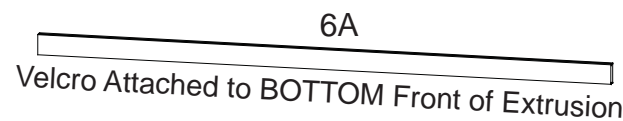
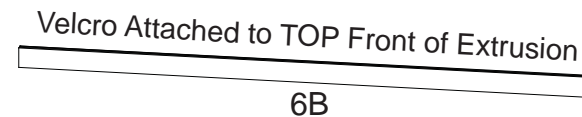

Note: Attaching Graphics
Attach Backwall Graphics to Velcro at the Top of the Upper Horizontals, at the Bottom of the Lower Horizontals and along the sides

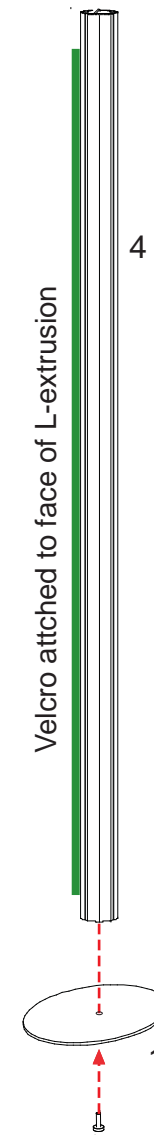

****L-Extrusions are highlighted in GREEN****
L-Extrusions must stay attached to uprights when shipping.

WHEN DISASSEMBLING ALUMINUM EXTRUSION, TIGHTEN ALL SETSCREWS AND LOCKS TO PREVENT LOSS DURING SHIPPING

866.652.2100

Item	Qty	Description
7	2	38" h Round Vertical Extrusion
8	1	38" h 135° Vertical Extrusion w/ Door Stop
8A	1	38" h 135° Vertical Extrusion w/ Door Hinge
9	4	12.5" w Horizontal Extrusion
10	2	Curved Horizontal Extrusion
	4	Internal Shelf Support

Steps

- 1) Attach lower horizontal extrusions [9] between assembled front section of pedestal and vertical extrusions [2 and 3] as shown.
- 2) Place inserts where indicated.
- 3) Attach upper horizontal extrusions [9] between vertical extrusions as shown.
- 4) Insert internal shelf and set atop velcroed supports.
- 5) Place counter atop assembled pedestal.

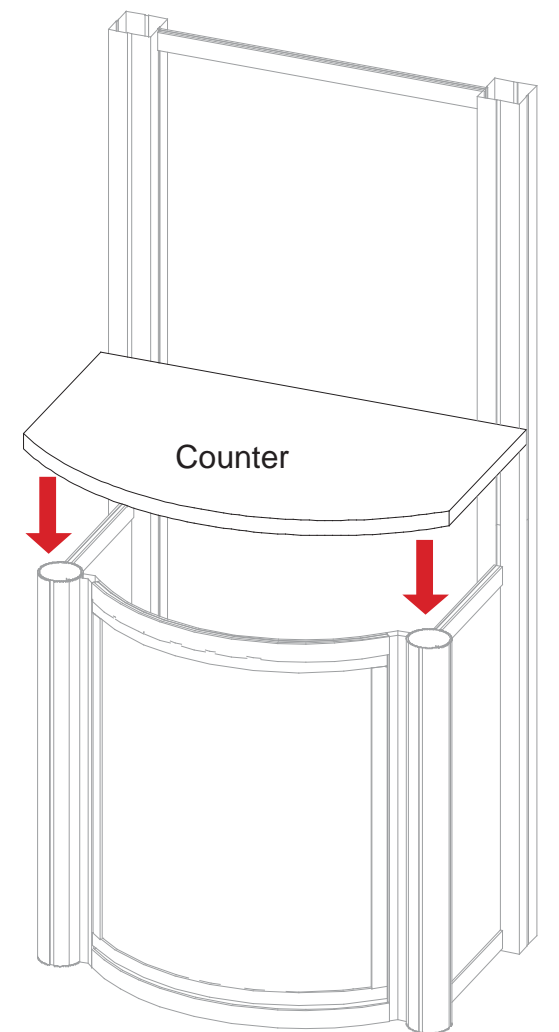
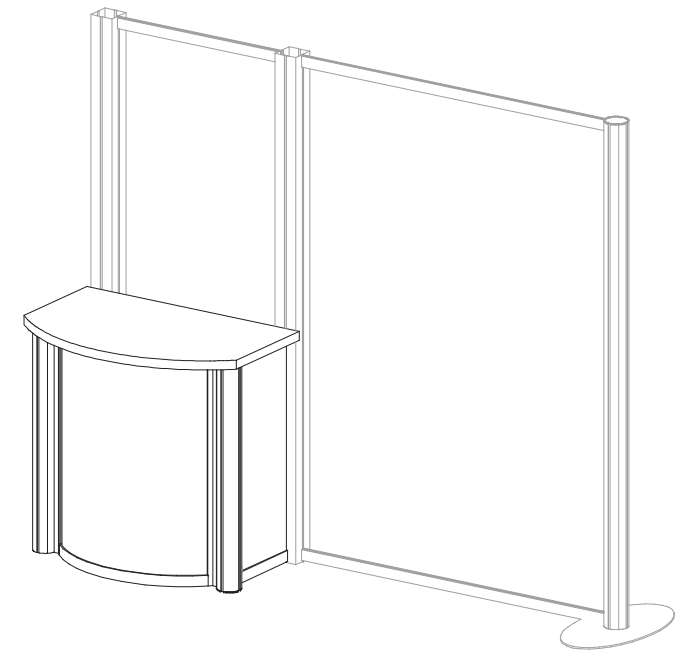
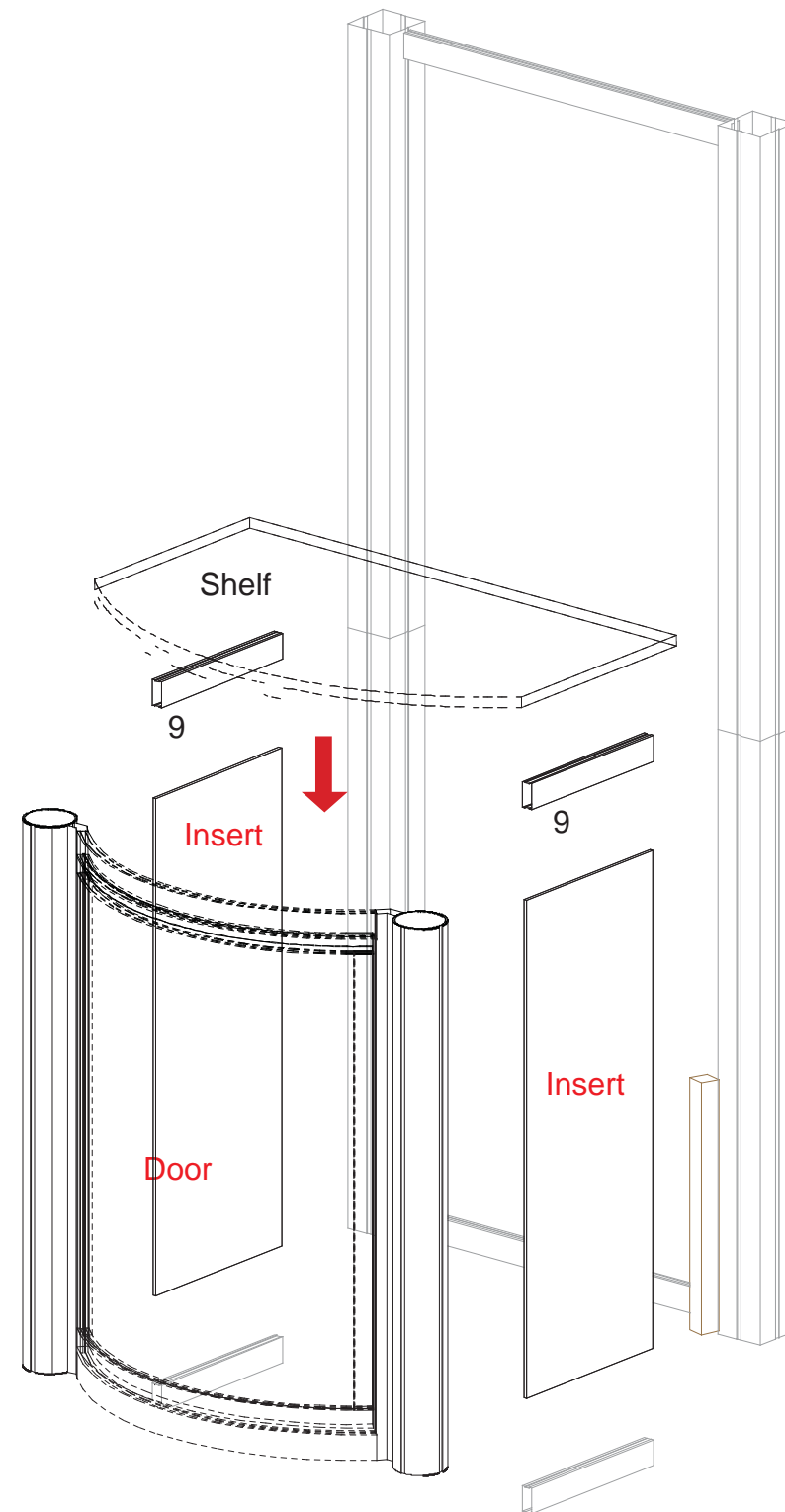
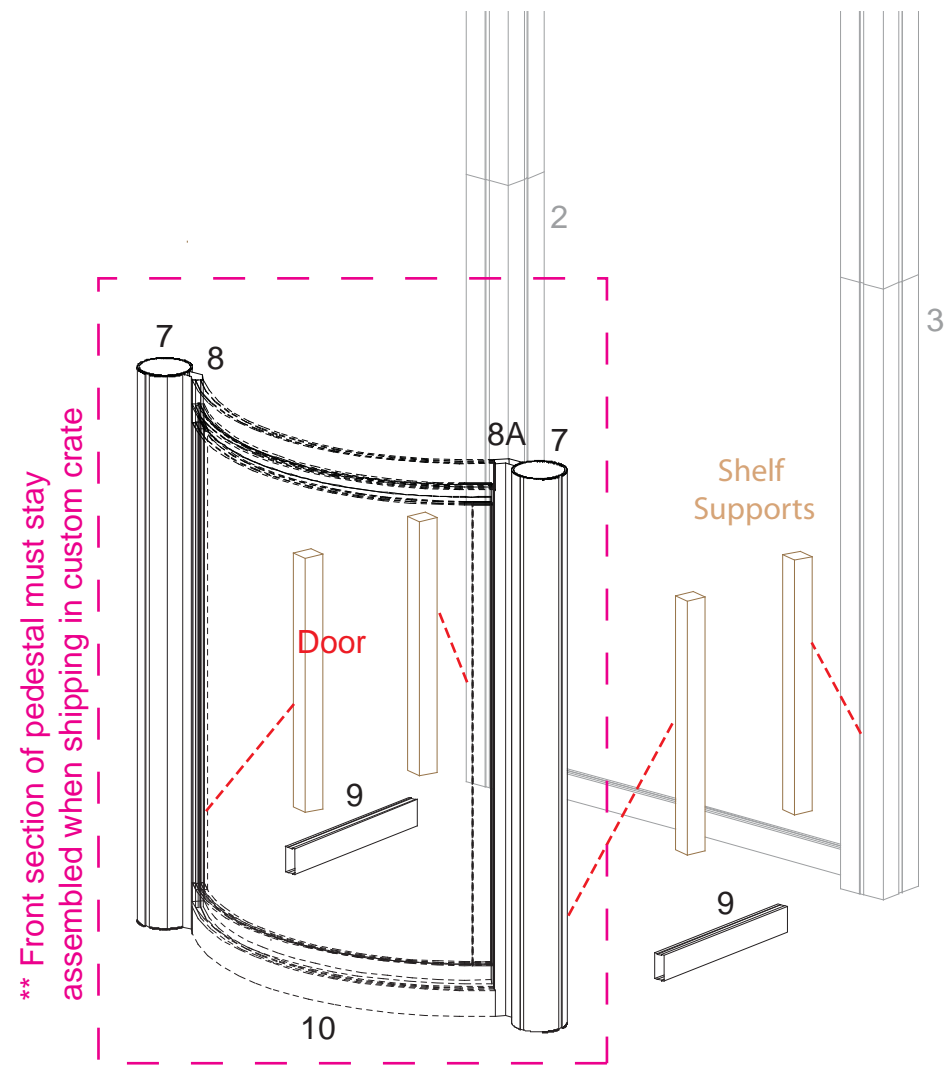

WHEN DISASSEMBLING ALUMINUM EXTRUSION, TIGHTEN ALL SETSCREWS AND LOCKS TO PREVENT LOSS DURING SHIPPING

Item	Qty.	Description
11	1	5.862"w Vertical Extrusion
12	1	5.862"w Vertical Extrusion
13	1	80.638"w Formed Horizontal Extrusion
14	1	78"w Horizontal Extrusion

Steps

- 1) Attach header to assembled backwall as shown.
- 2) Attach Sign using standoff barrels and caps.
- 3) Attach wings using A10 clamps as shown.

866.652.2100

Graphic Attachment

Graphic
Standoff Barrel
Cap

Slide connector on back of standoff barrels into groove of extrusion and twist to secure in place. Secure graphic to standoffs using screw caps.

Note: Attaching Graphics
Attach Header Graphic to Back of assembled header frame.

**** Header must stay assembled when shipping in custom crate**

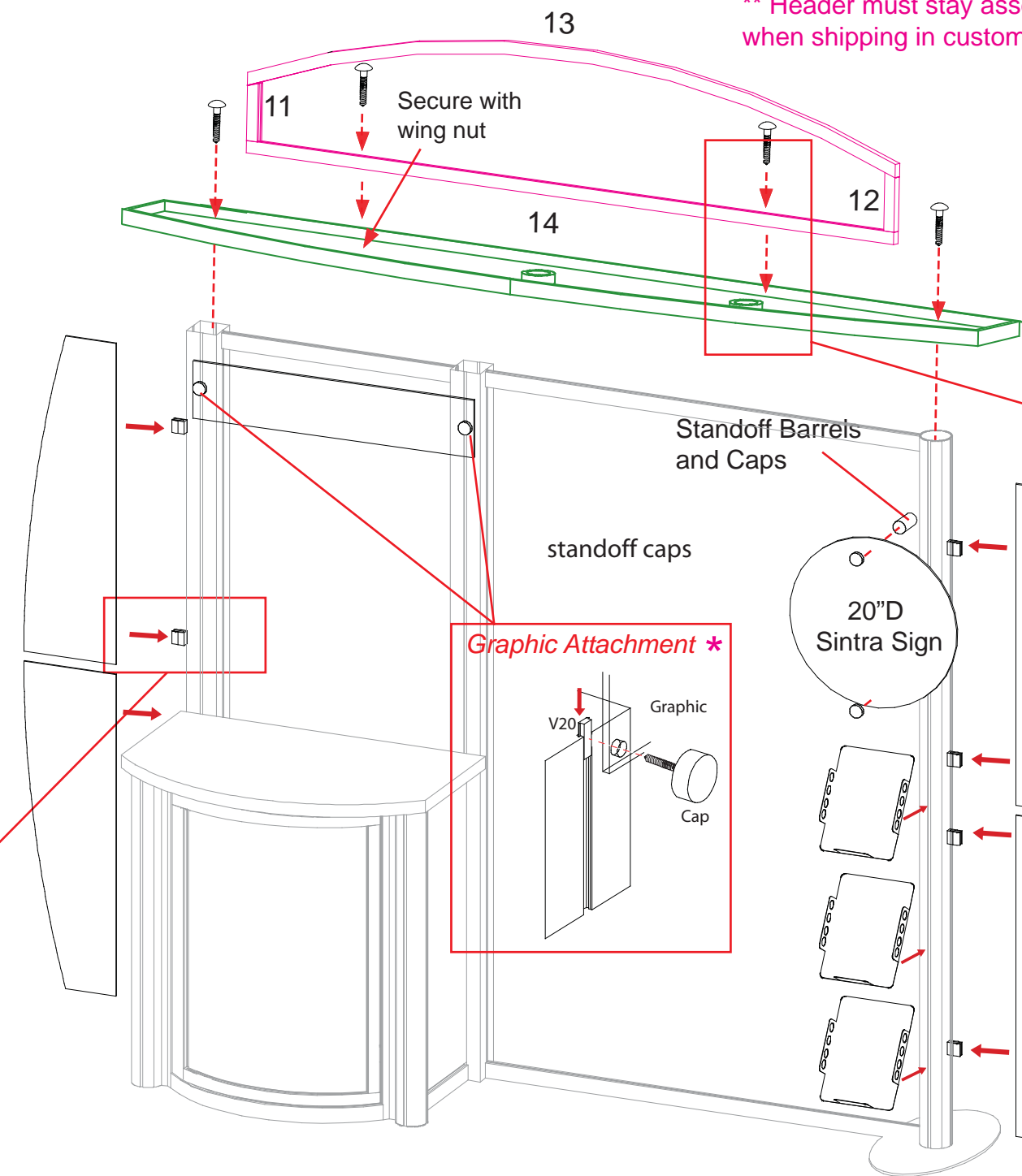

Monitor Mount Attachment

Attach mounting plate to verticals as shown.

Then attach wall plate to plate using bolts and wing nuts

Header Attachment

Bolt
Wing Nut

Example of A10 Clamp Attachment

Slide connector on back of A10 clamp into groove of extrusion.

When desired location is found, tighten set screw to secure.

Tighten knob to secure shelf in place.

Literature Rack Attachment

Tighten Lock to Secure

Attach connector piece to rack as shown. Then connect assembled literature rack to vertical extrusion.

WHEN DISASSEMBLING ALUMINUM EXTRUSION, TIGHTEN ALL SETSCREWS AND LOCKS TO PREVENT LOSS DURING SHIPPING

Item	Qty.	Description
15	1	18"D Round Base Plate
16	1	80"h Round Vertical Extrusion
17	1	36"h Round Vertical Extrusion

****Kiosk must stay assembled when shipping in custom crate****

866.652.2100

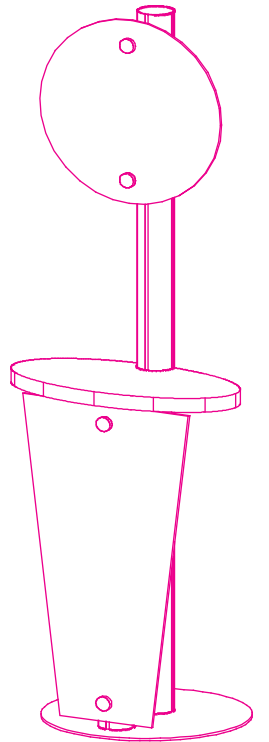
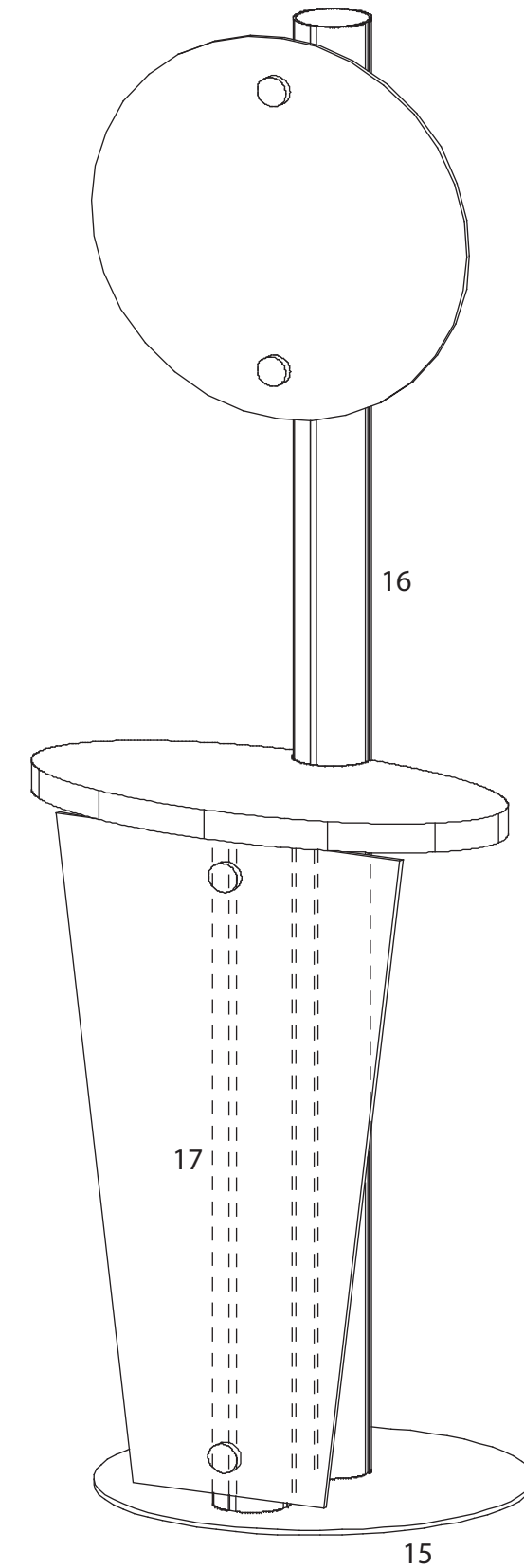
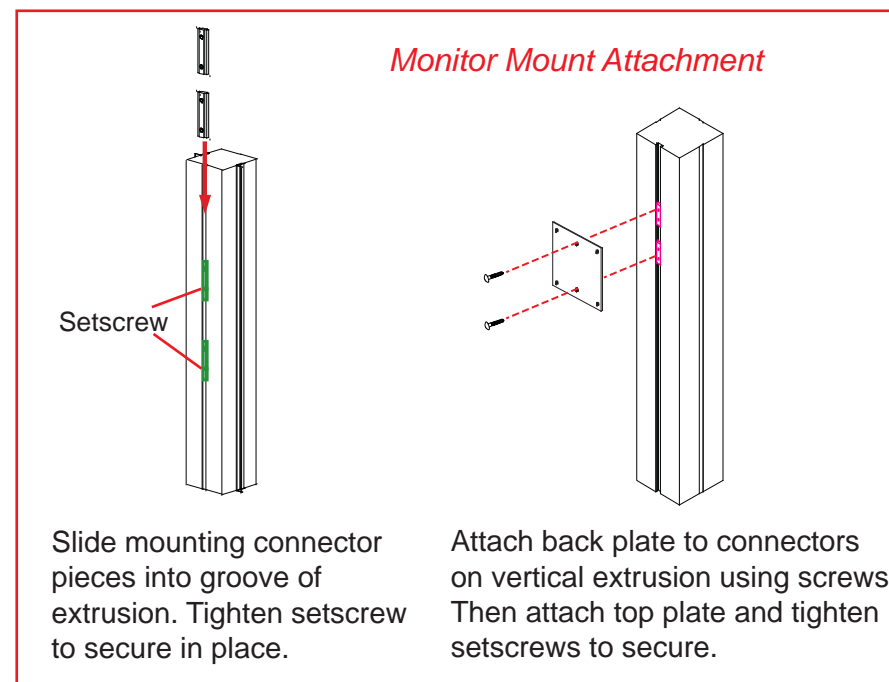
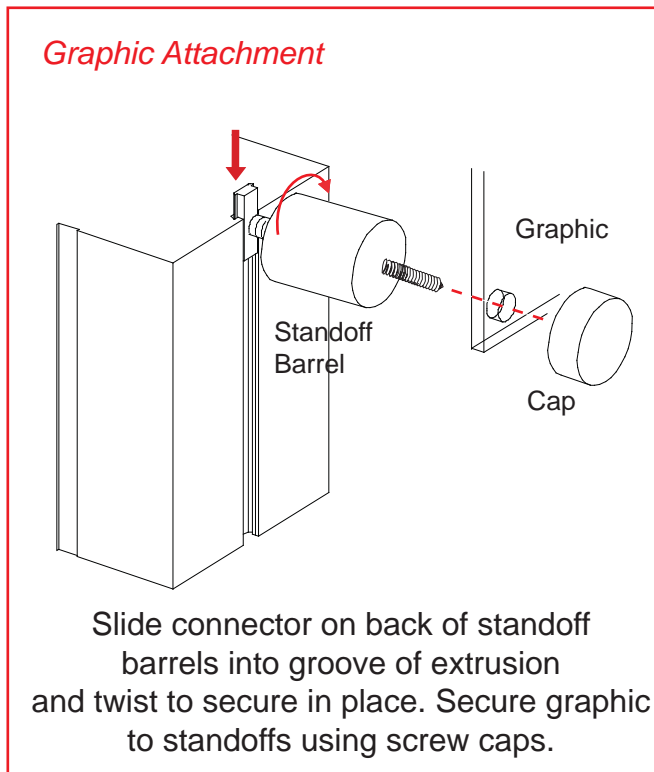

WHEN DISASSEMBLING ALUMINUM EXTRUSION, TIGHTEN ALL SETSCREWS AND LOCKS TO PREVENT LOSS DURING SHIPPING



Round Graphics & Pedestal Inserts

Level 5

Level 4

Level 3

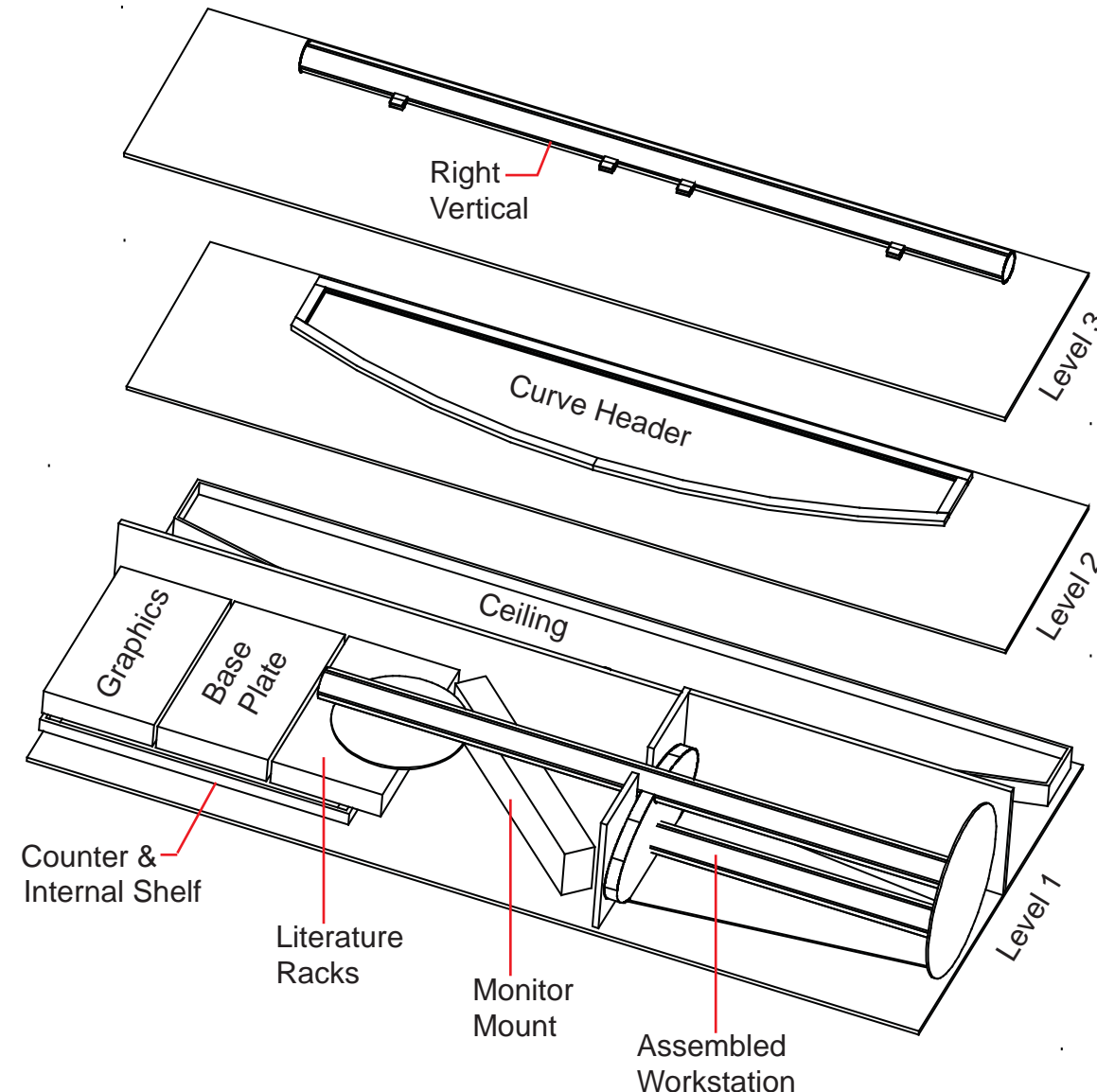
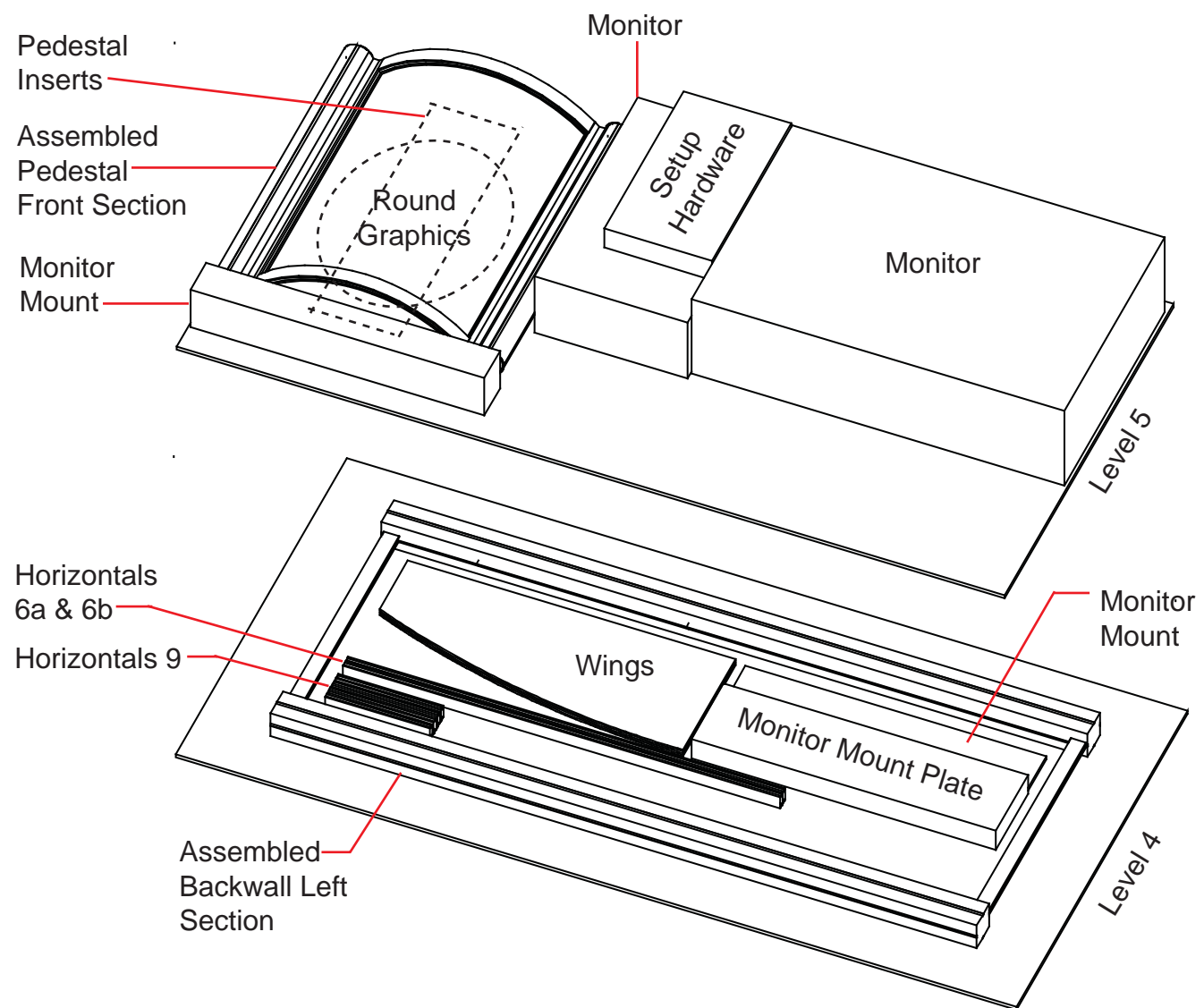

Level 2

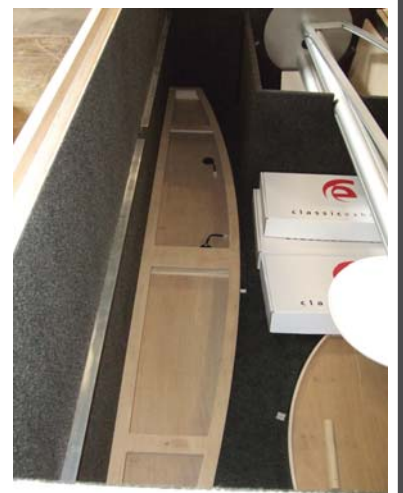

Level 1

WHEN DISASSEMBLING ALUMINUM EXTRUSION, TIGHTEN ALL SETSCREWS AND LOCKS TO PREVENT LOSS DURING SHIPPING