

WHEN DISASSEMBLING ALUMINUM EXTRUSION, TIGHTEN ALL SETSCREWS AND LOCKS TO PREVENT LOSS DURING SHIPPING

# visionary™ DESIGNS

## Using Your Setup Instructions

The Visionary Designs Setup Instructions are created specifically for your configuration. They are laid out sequentially, including an exploded view of the entire display, and then a logical series of detailed steps to assemble the main structure and components. We encourage you to study the instructions **before** attempting to assemble your exhibit.

Each page reminds you to tighten the setscrews after disassembling your exhibit to prevent loss of the locks and setscrews (see below in RED). This is VERY IMPORTANT.

## Cleaning and Packing Your Display

- 1) Use care when cleaning aluminum extrusion or acrylic inserts. Use only non-abrasive cleaners.
- 2) When cleaning laminate inserts or countertops, use mild cleansers and a soft material such as cotton.
- 3) Keep all display components away from extreme heat and long exposure to sunlight to avoid warping and fading.
- 4) Retain all packing material. It will make re-packing much easier and will reduce the likelihood of shipping damage.



**The Tool**

Most Visionary Designs exhibits can be assembled with the supplied Hex Key Tool. Occasionally, a flat head screwdriver may be required.



**Typical Connection**

Most horizontal extrusion connections have a patented expandable lock. This lock inserts into the groove of an opposing extrusion. Tightening the lock with the Hex Key Tool expands the lock and creates a strong positive connection.



**Typical Connection (cont'd)**

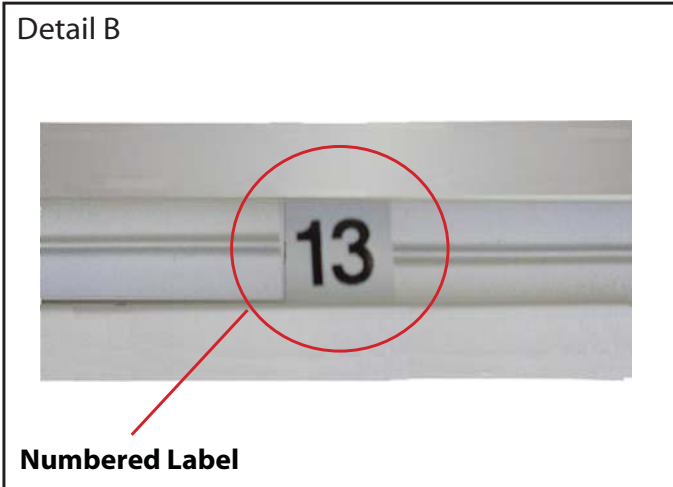

**Numbered Label**

Each extrusion contains a numbered label which corresponds with setup instructions. The label is located within a groove of the extrusion (when possible). With Visionary Designs the labels contain Black numbers unless otherwise specified.



**Horizontal Inline Connection** (remove only one setscrew)

Remove only (1) setscrew when disassembling. Replace setscrew in extrusion after assembling it. Before packing, replace setscrew in extrusion to avoid losing it.

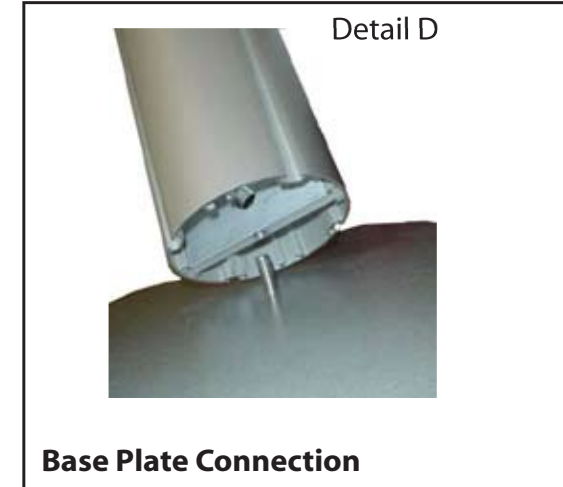

**Base Plate Connection**

Attach base plate to round or square vertical extrusion using the bolt provided. Be careful not to strip the threads.

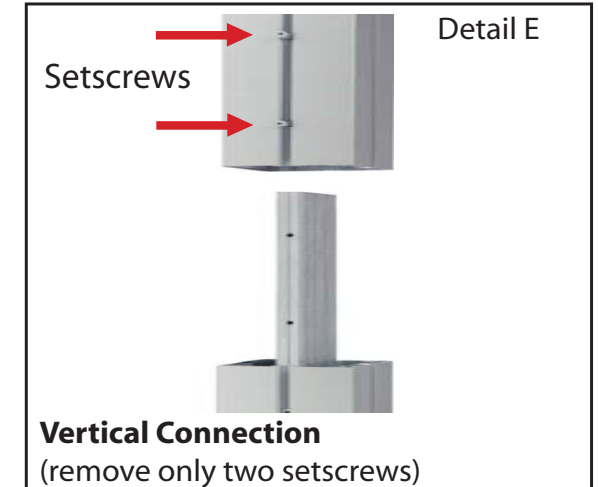

**Vertical Connection**  
(remove only two setscrews)

When vertical extrusions are packed in portable cases rather than crates or tubs, they must be broken down into smaller sections which then require assembly.

Remove only (2) setscrews when disassembling. Replace setscrews in extrusion after assembling it. Before packing, replace setscrews in extrusion to avoid losing them.

**WHEN DISASSEMBLING ALUMINUM EXTRUSION, TIGHTEN ALL SETSCREWS AND LOCKS TO PREVENT LOSS DURING SHIPPING**

866.652.2100

Item	Qty.	Description
1	2	Base Plate w/ 1 Hole
1a	1	Base Plate w/ 2 Holes
2	1	42" h Lower Square Vertical Extrusion
3	1	42" h Upper Square Vertical Extrusion
4	1	42" h Lower Square Vertical Extrusion
5	1	42" h Upper Square Vertical Extrusion
6	1	42" h Lower Square Vertical Extrusion
7	1	32" h Upper Square Vertical Extrusion
8	1	42" h Lower Square Vertical Extrusion
9	1	42" h Upper Square Vertical Extrusion
10/10a	1/1	47" w Horizontal Extrusion
11	1	38.25" w Horizontal Extrusion
12	1	40.9826" Curved Extrusion
14	1	4" Stabilizing Extrusion

**Steps:**

- 1) Attach vertical extrusions [2, 4, 6 and 8] to base plates [1 and 1a].
- 2) Attach upper vertical extrusions [3, 5, 7 and 9] to lower extrusions [2, 4, 6 and 8] using connection bar [b].
- 4) Connect stabilizing bar [14] between verticals [5 and 7], refer to detail.
- 5) Attach horizontal extrusions [10, 10a, 11 and 12] between vertical assemblies as shown.
- 6) Apply graphic to back of assembled backwall.

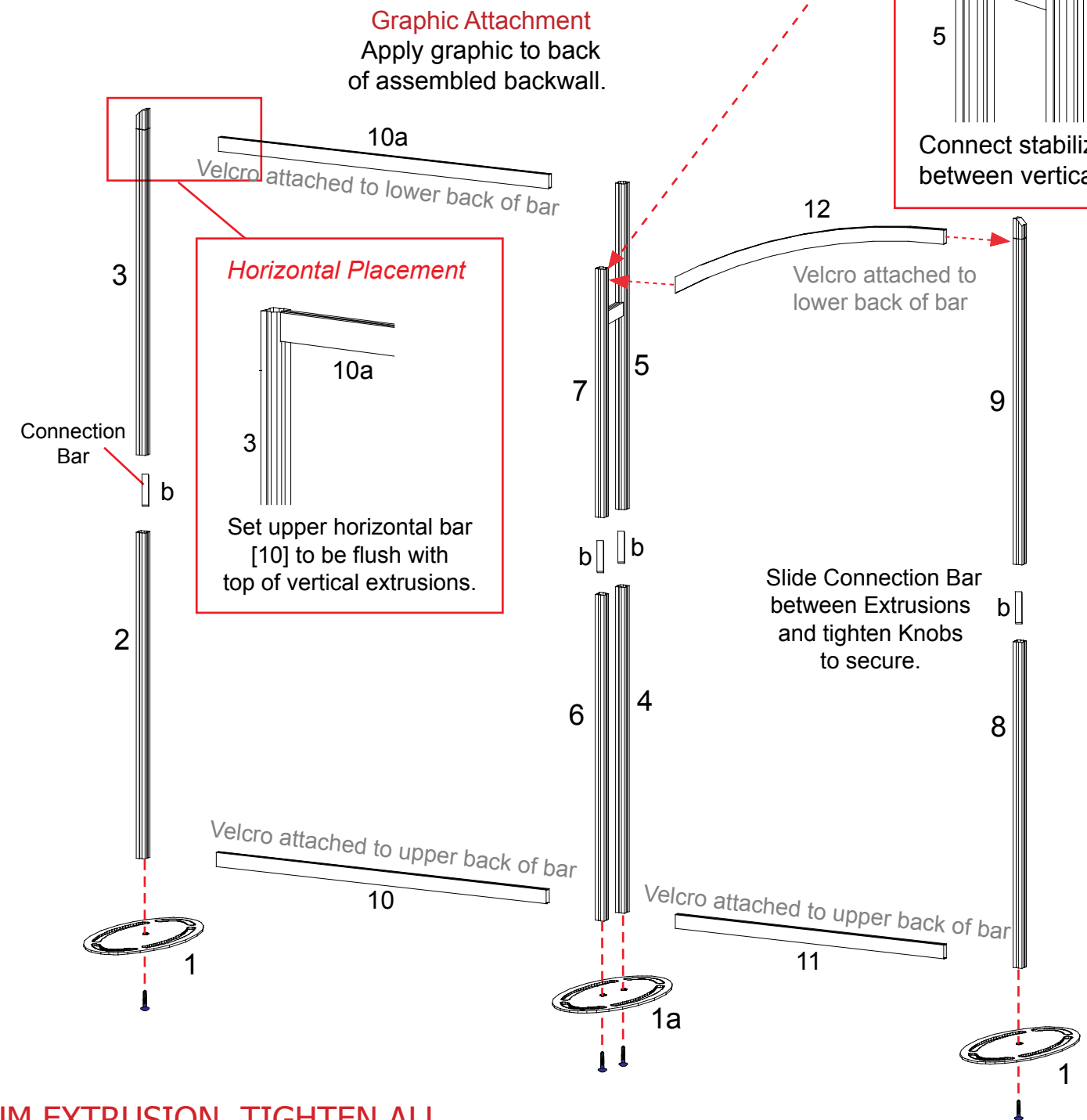
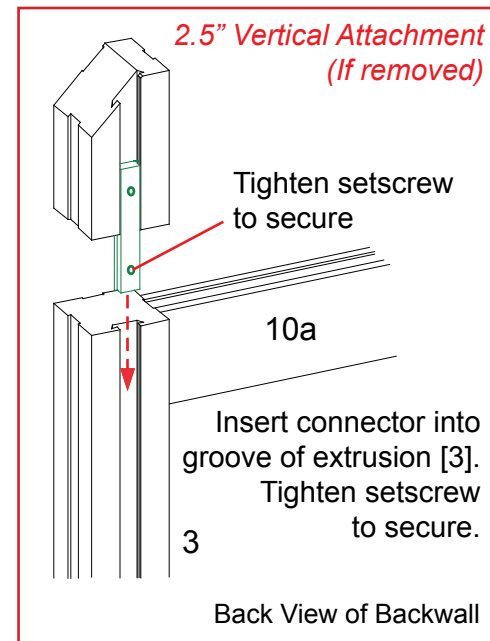

**STAR** indicates location of knobs on BACKSIDE of unit.

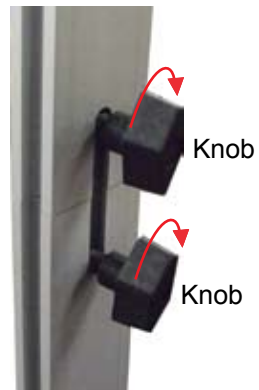

Turn Knob Clockwise to Tighten Lock

\*\*Do not over tighten Knobs.\*\*

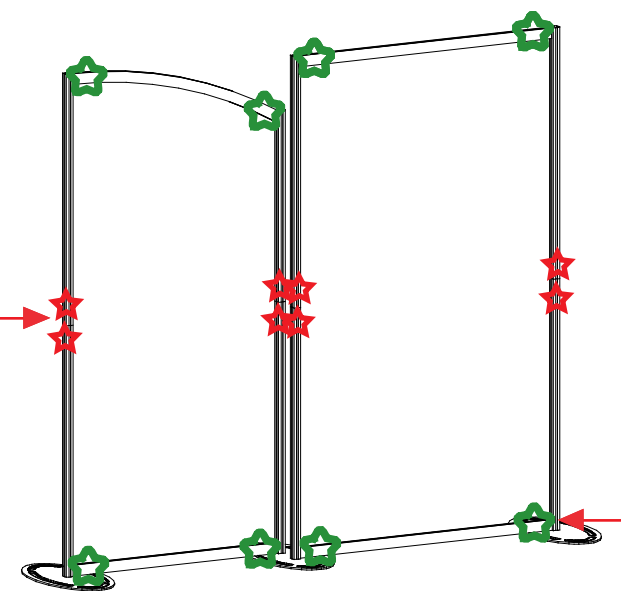

**GREEN STAR** indicates location of connection lock with knob.



**WHEN DISASSEMBLING ALUMINUM EXTRUSION, TIGHTEN ALL SETSCREWS AND LOCKS TO PREVENT LOSS DURING SHIPPING**

866.652.2100

Item	Qty.	Description
1	2	Base Plate w/ 1 Hole
1a	1	Base Plate w/ 2 Holes
2a	1	42"h Lower Square Vertical Extrusion
3a	1	42"h Upper Square Vertical Extrusion
4a	1	42"h Lower Square Vertical Extrusion
5a	1	42"h Upper Square Vertical Extrusion
6a	1	42"h Lower Square Vertical Extrusion
7a	1	32"h Upper Square Vertical Extrusion
8a	1	42"h Lower Square Vertical Extrusion
9a	1	42"h Upper Square Vertical Extrusion
10/10a	1/1	47"w Horizontal Extrusion
11	1	38.25"w Horizontal Extrusion
12a	1	40.9826" Curved Extrusion
13	2	24"w Horizontal Extrusion
14	1	4" Stabilizing Extrusion

Steps:

- 1) Attach vertical extrusions [2a, 4a, 6a and 8a] to base plates [1 and 1a].
- 2) Attach upper vertical extrusions [9a, 5a, 7a and 3a] to lower extrusions [8a, 4a, 6a and 2a] using connection bar [b].
- 3) Attach lower horizontal extrusions [10, 10a, 11 and 12a] between vertical assemblies as shown.
- 4) Connect stabilizing bar [14] between vertical extrusions [5a and 7a], refer to detail.
- 5) Apply graphic to back of assembled backwall.

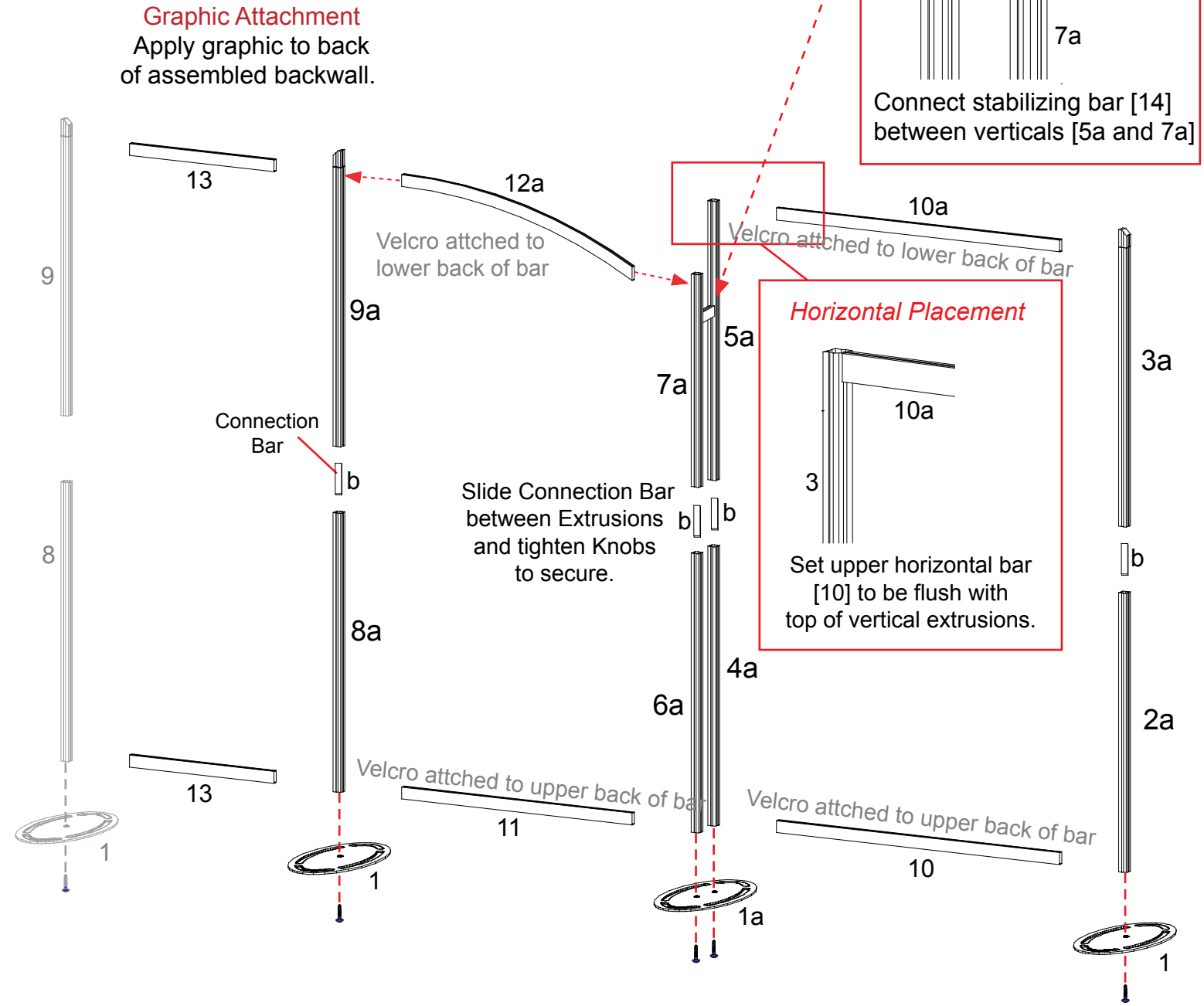
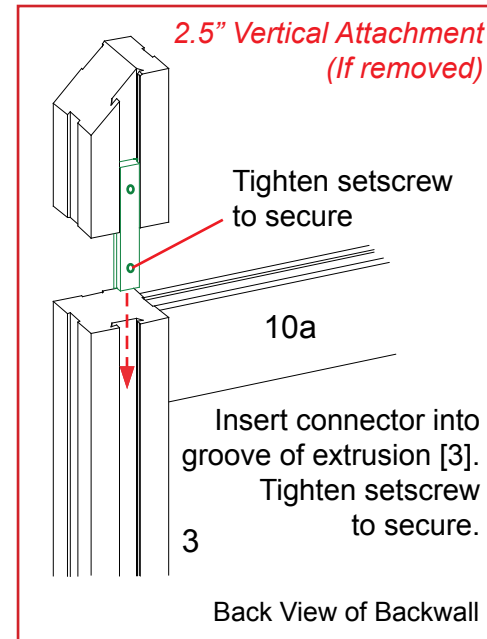

**STAR** indicates location of knobs on BACKSIDE of unit.

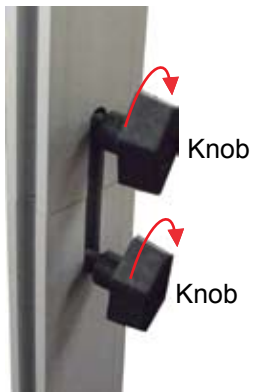

Turn Knob Clockwise to Tighten Lock

**\*\*Do not over tighten Knobs.\*\***

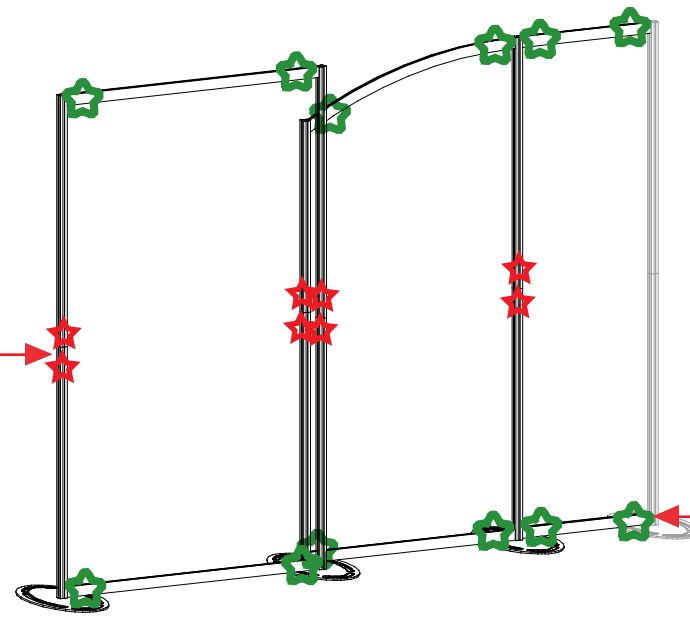

**GREEN STAR** indicates location of connection lock with knob.



**WHEN DISASSEMBLING ALUMINUM EXTRUSION, TIGHTEN ALL SETSCREWS AND LOCKS TO PREVENT LOSS DURING SHIPPING**

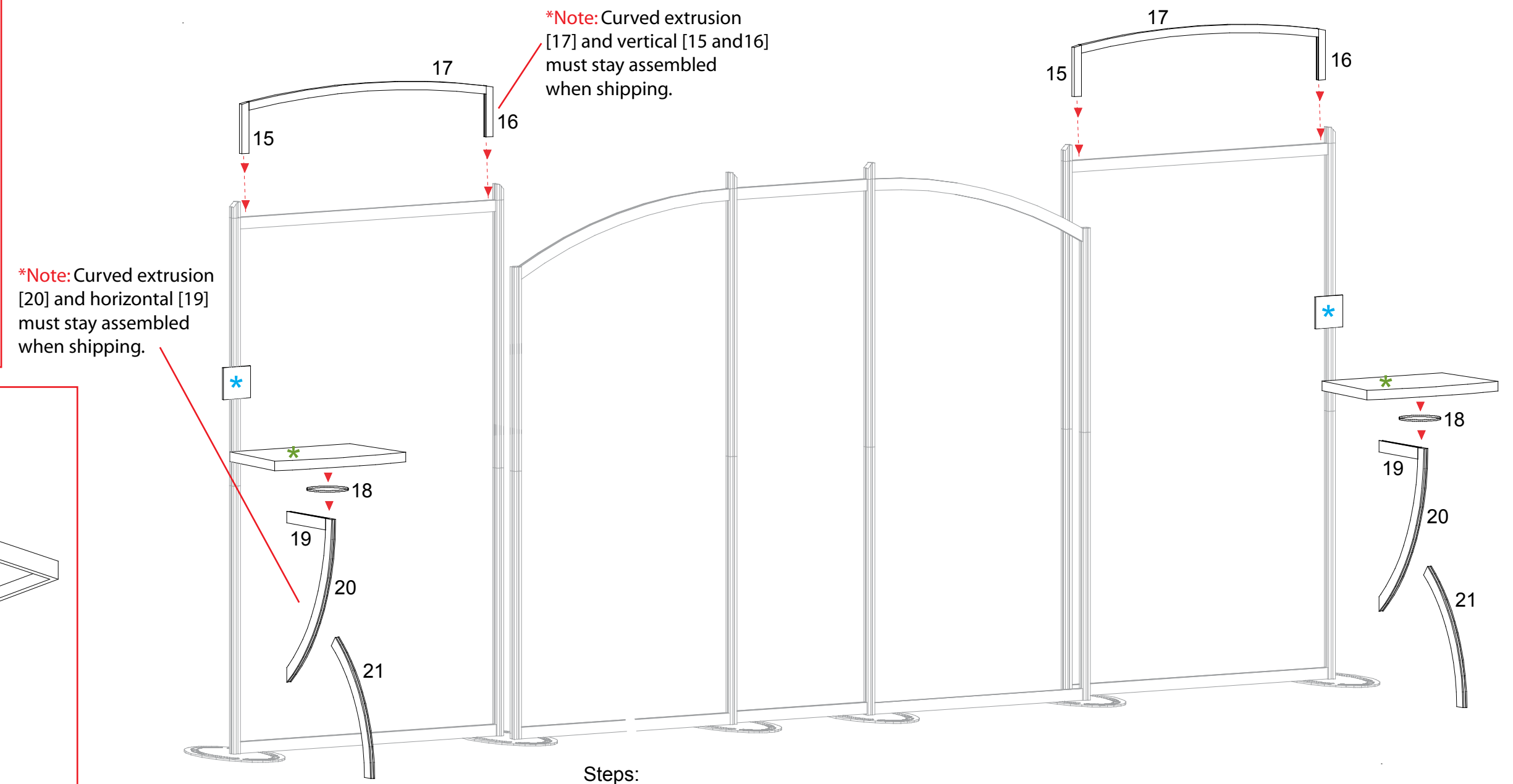
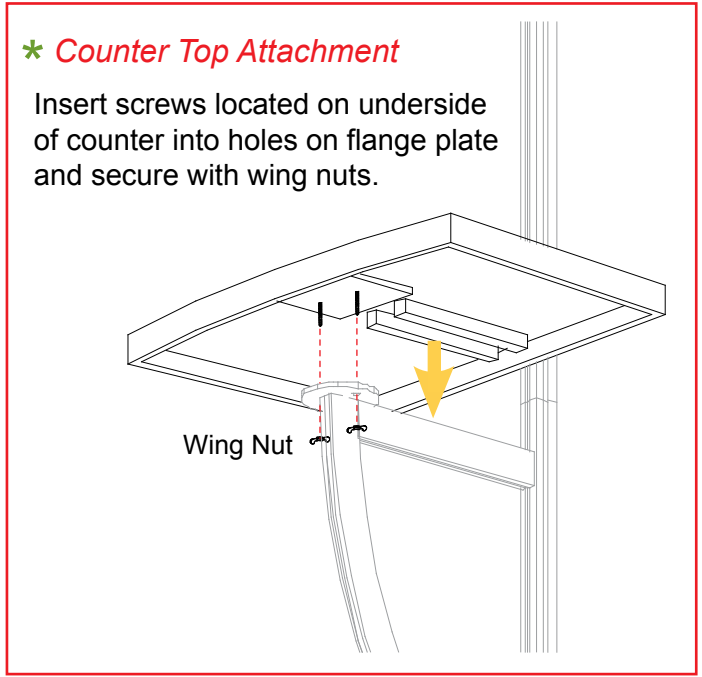
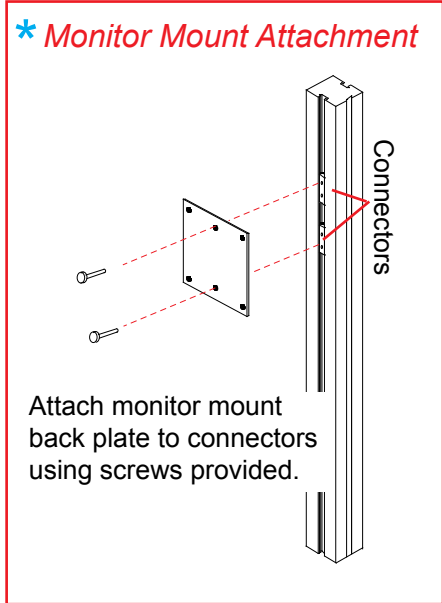

- Steps:
- 1) Connect curved horizontal extrusion [17] between vertical extrusions [15 and 16].
  - 2) Repeat steps for additional header.
  - 2) Attach both assembled headers to top of assembled backwall as shown.
  - 3) Connect horizontal extrusion [19] to curved extrusion [20].
  - 4) Attach curved extrusion [21] to curved extrusion [20].
  - 5) Attach assembled counter support [19/20/21] to vertical where indicated.
  - 6) Attach flange plate [18] to top of curved extrusion [20] by inserting screw through top of [18], into top of vertical [20] and secure.
  - 7) Attach counter atop support, see counter top attachment detail this page.
  - 8) Repeat steps for additional backwall counter.

Item	Qty.	Description
15	2	9.2856" h Vertical extrusion
16	2	9.2856" h Vertical extrusion
17	2	43.66" w Curved Horizontal Extrusion
18	2	Flange Plate
19	2	12.184" w Horizontal Extrusion
20	2	30.2" Curved Extrusion
21	2	Curved Leg Support

**WHEN DISASSEMBLING ALUMINUM EXTRUSION, TIGHTEN ALL SETSCREWS AND LOCKS TO PREVENT LOSS DURING SHIPPING**

866.652.2100

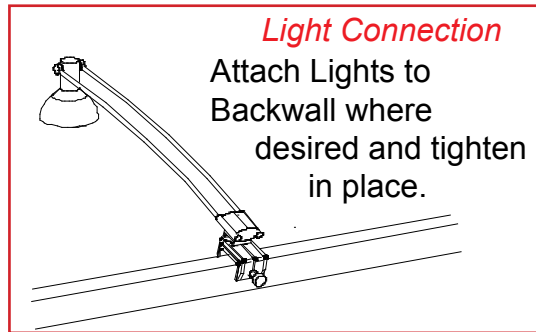

Attach Lights to Backwall where desired and tighten in place.

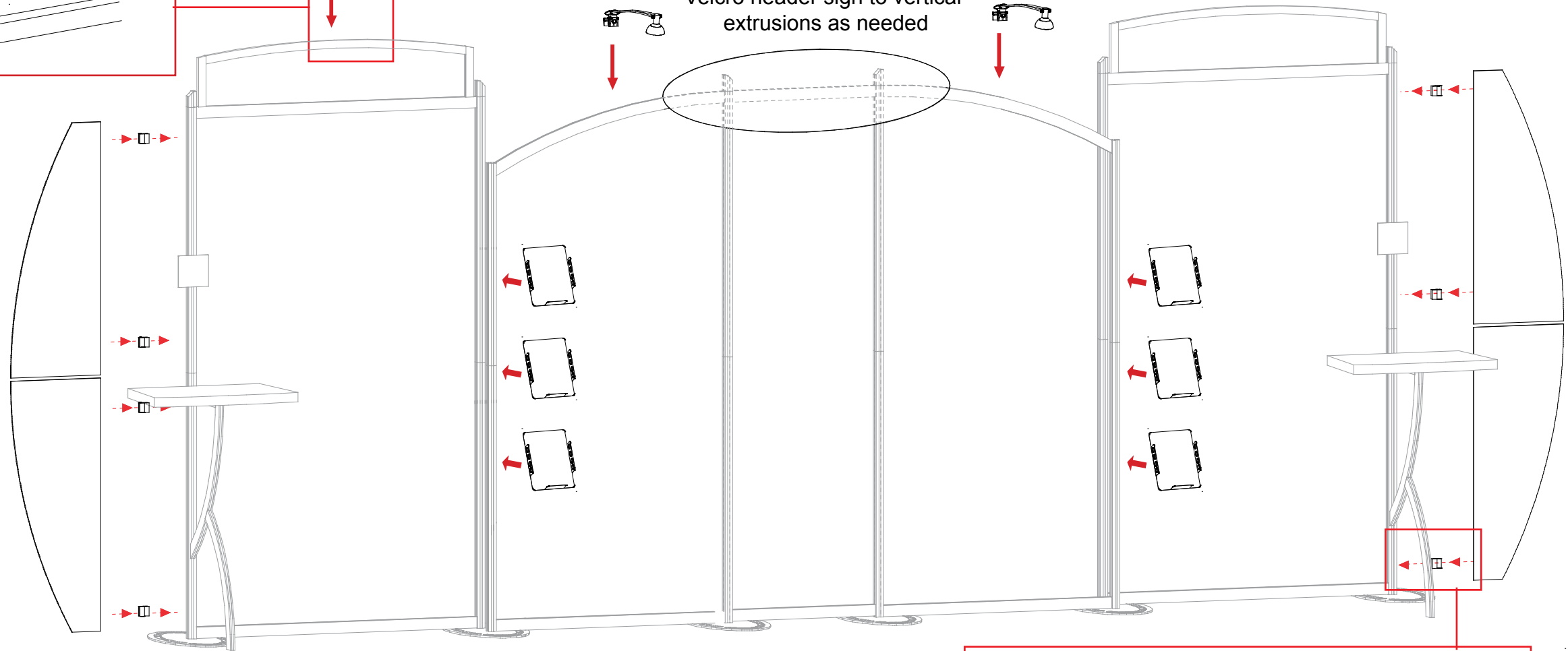

Velcro header sign to vertical extrusions as needed

- Steps:
- 1) Attach wings to vertical extrusions as shown.
  - 2) Apply graphic to back of assembled backwall.
  - 2) Attach oval graphic header centered to backwall as shown.
  - 3) Attach lights to top of assembled backwall as indicated.
  - 4) Attach lit. racks as desired.

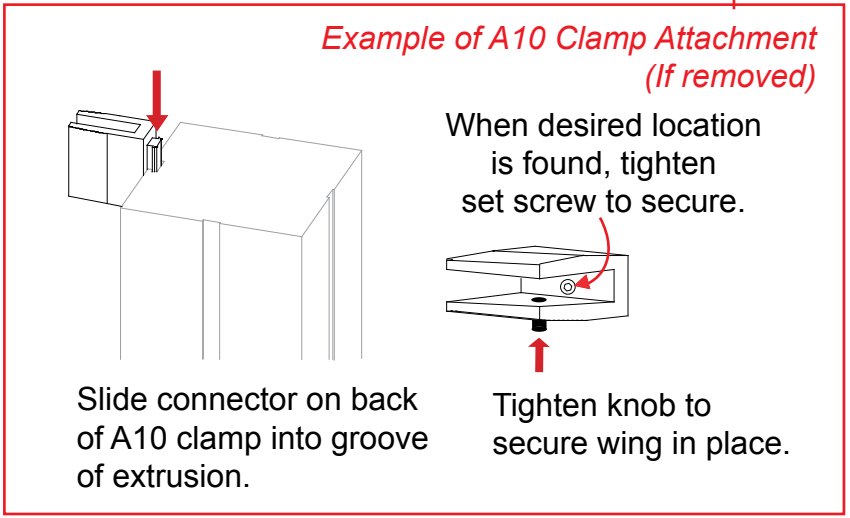

Example of A10 Clamp Attachment (If removed)

When desired location is found, tighten set screw to secure.

Slide connector on back of A10 clamp into groove of extrusion.

Tighten knob to secure wing in place.

**WHEN DISASSEMBLING ALUMINUM EXTRUSION, TIGHTEN ALL SETSCREWS AND LOCKS TO PREVENT LOSS DURING SHIPPING**

866.652.2100

Part Number	Qty	Description
22	4	38" h Vertical Extrusion
23/23a	2/2	12" w Horizontal Extrusion
24	2	25" w Horizontal Extrusion

Steps

- 1) Attach horizontal extrusions [23 and 23a] between vertical extrusions [22], placing inserts between horizontals.
- 2) Attach curved horizontal extrusions [24] between vertical extrusions [22], placing insert between curved horizontals.

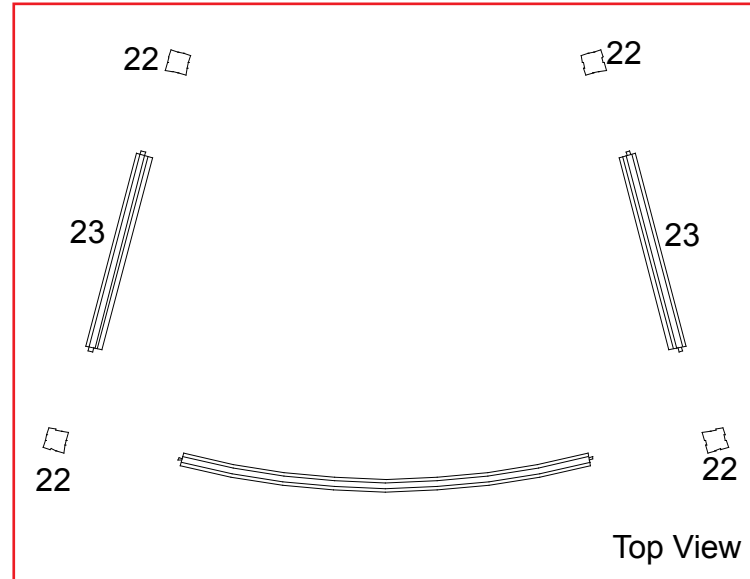

Steps (Cont'd):

- 3) Place shelf atop lip of extrusions.
- 4) Set counter top atop assembled base.

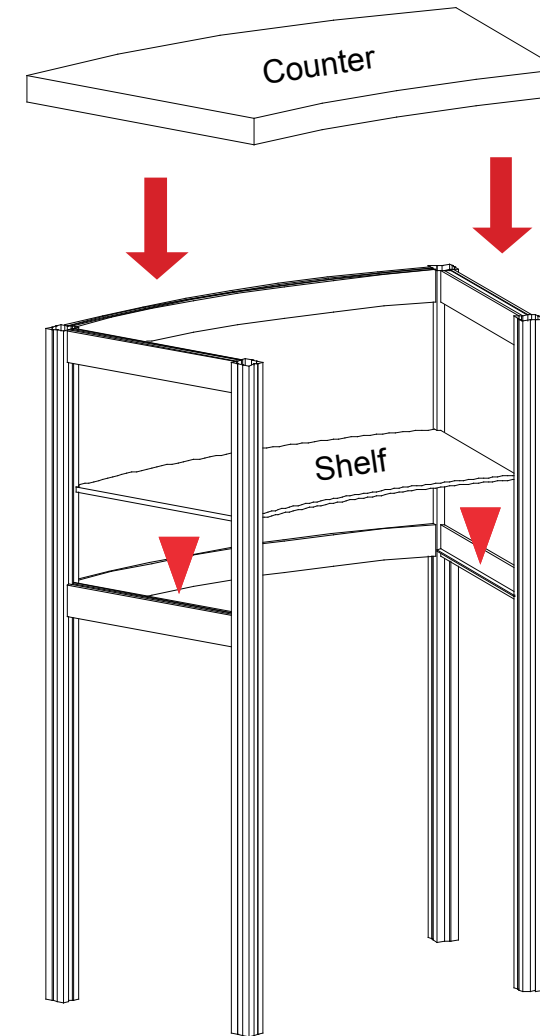
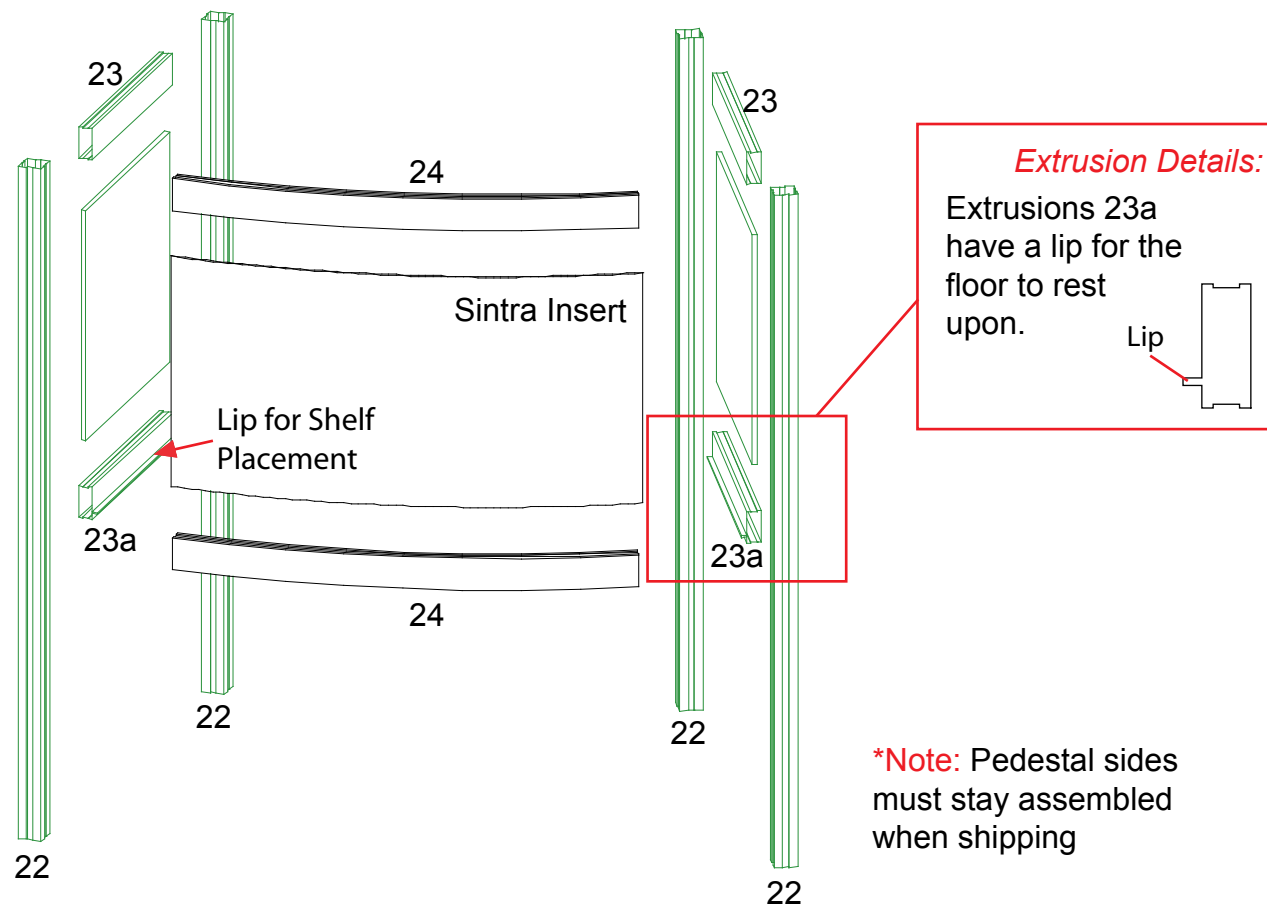
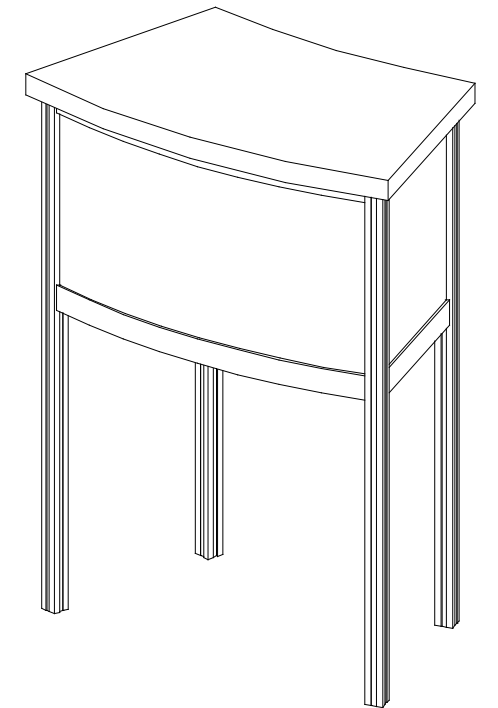

**WHEN DISASSEMBLING ALUMINUM EXTRUSION, TIGHTEN ALL SETSCREWS AND LOCKS TO PREVENT LOSS DURING SHIPPING**

Top View of each Level

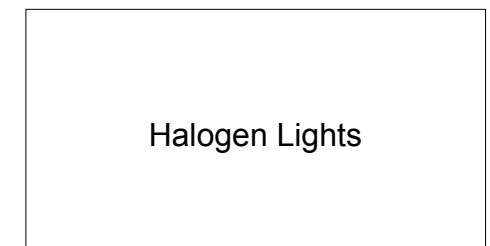
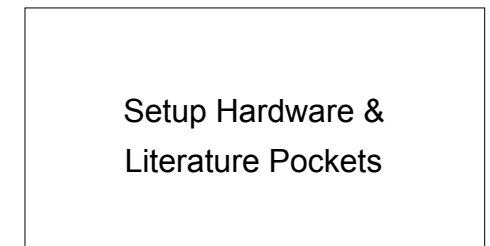
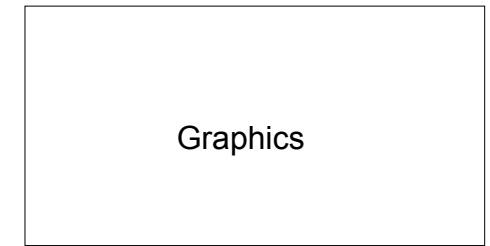
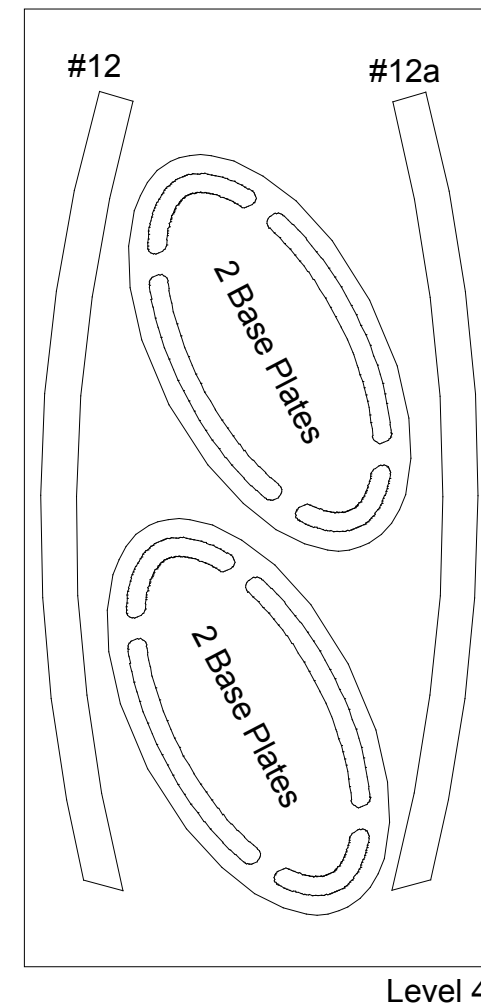
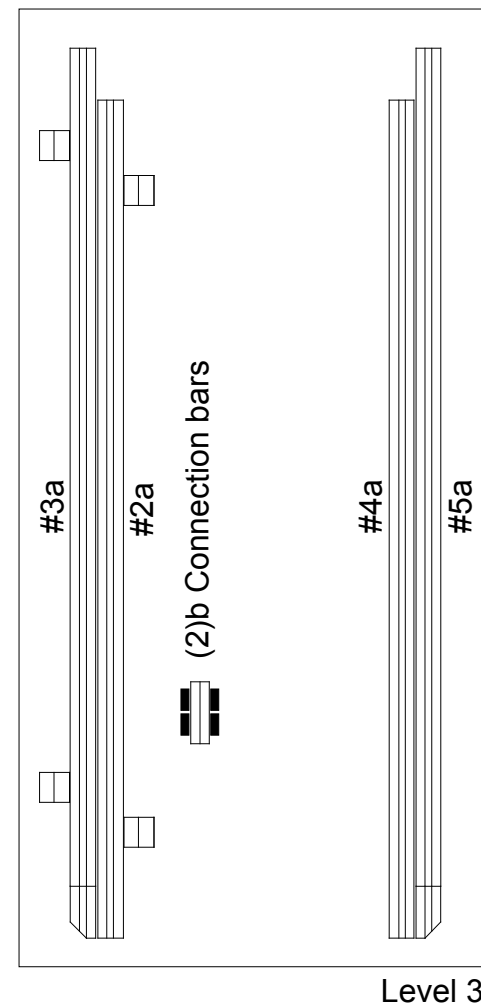
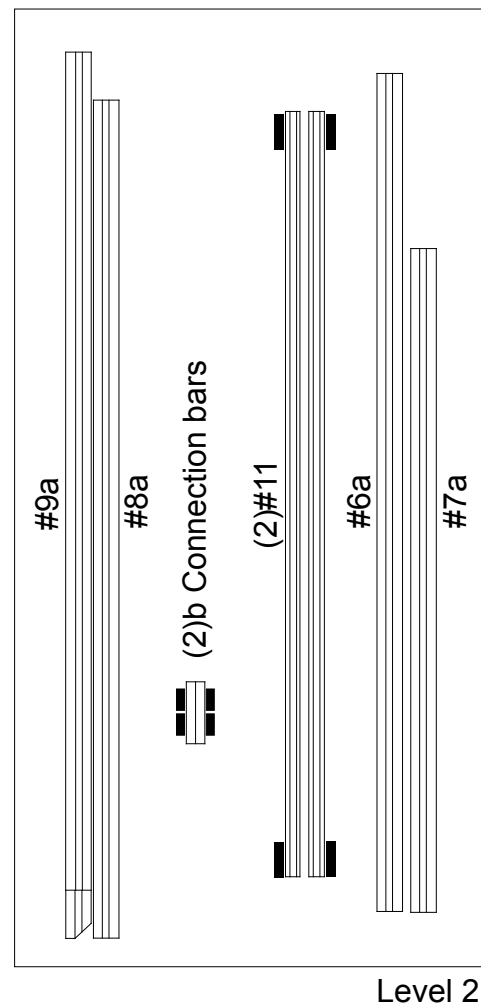
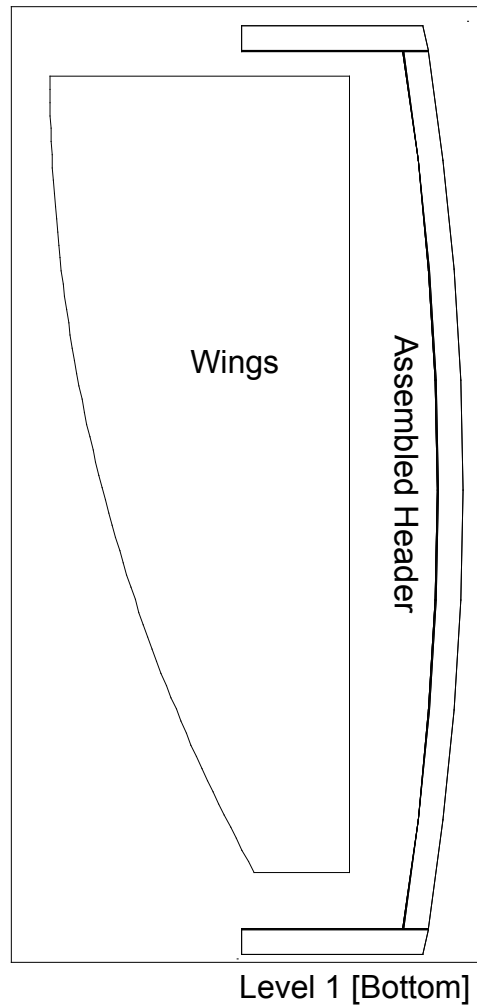

WHEN DISASSEMBLING ALUMINUM EXTRUSION, TIGHTEN ALL SETSCREWS AND LOCKS TO PREVENT LOSS DURING SHIPPING

Top View of each Level

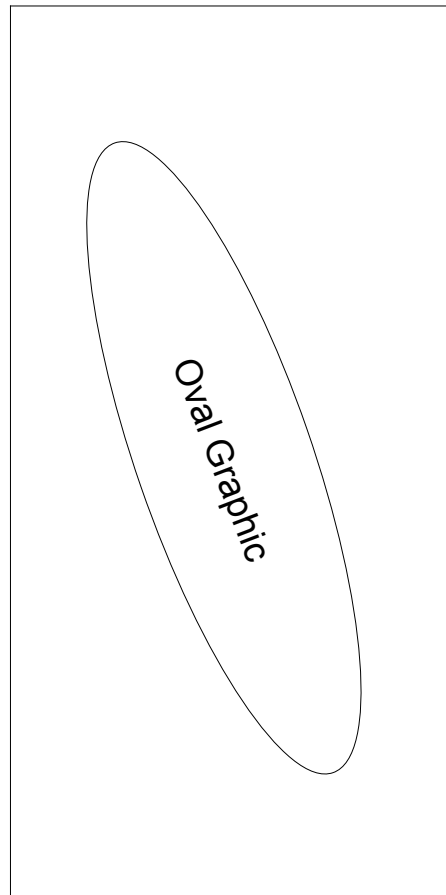

Level 1 [Bottom]

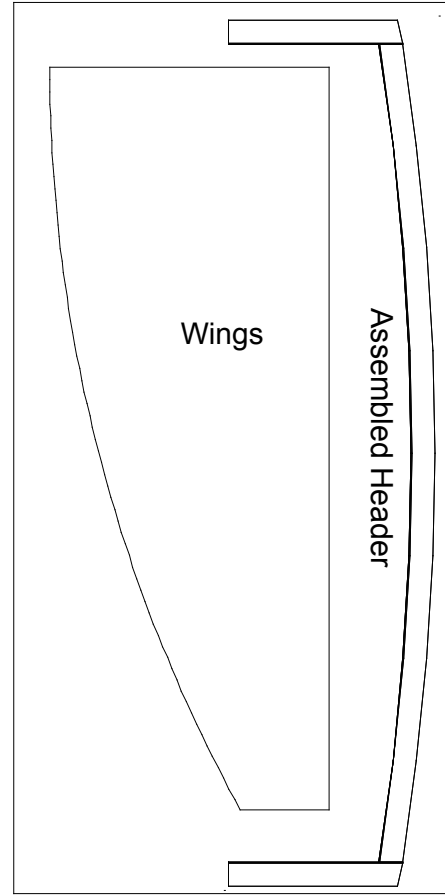

Level 2

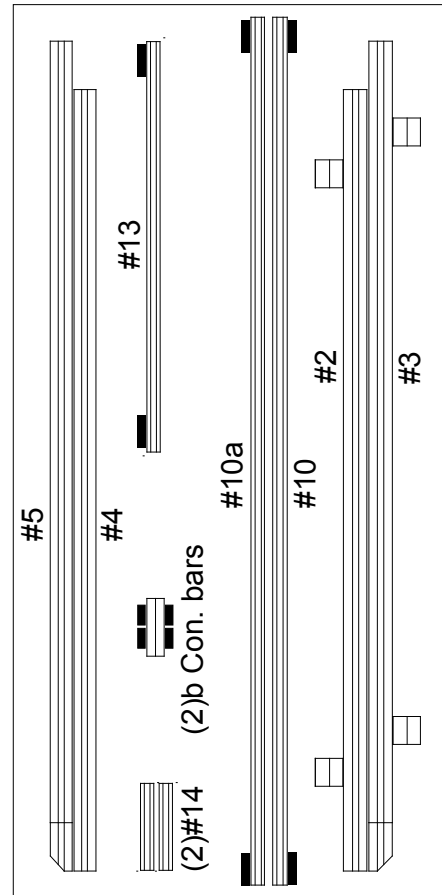

Level 3

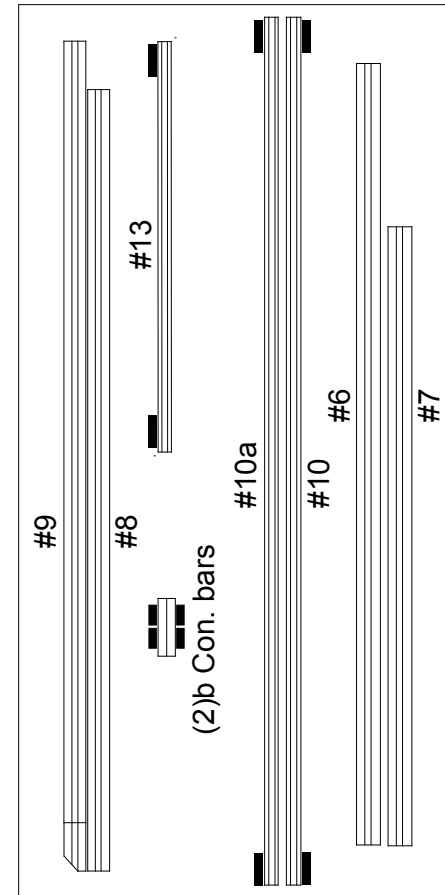

Level 4

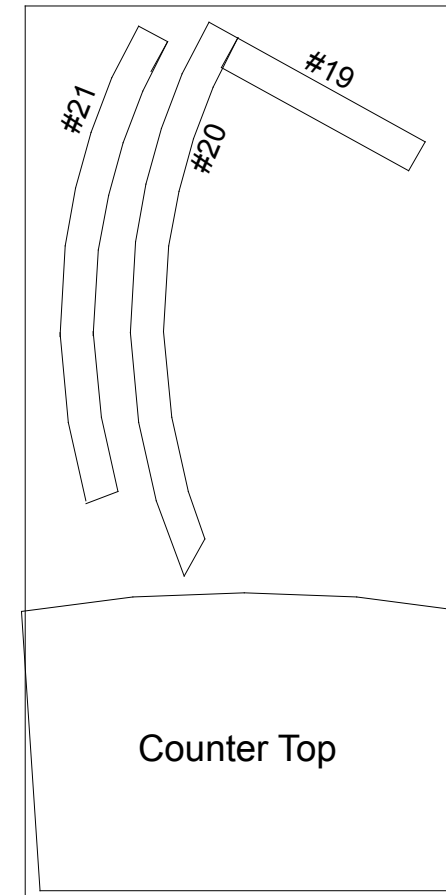

Level 5

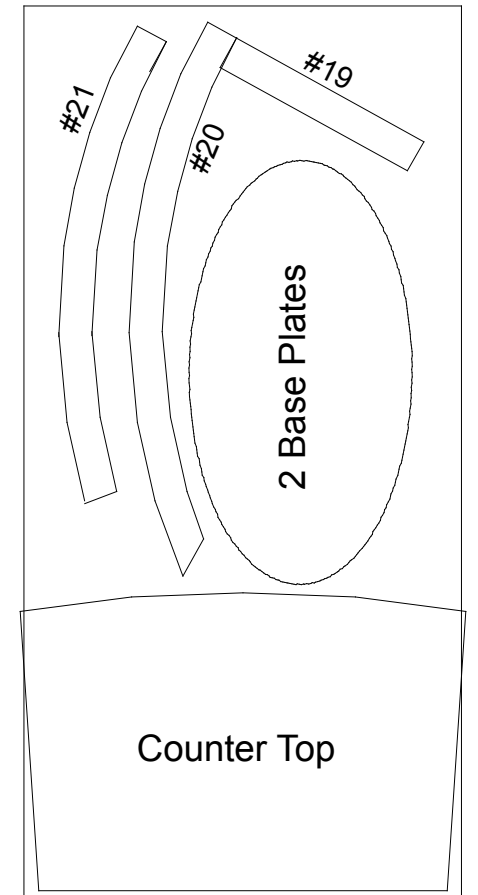

Level 6

WHEN DISASSEMBLING ALUMINUM EXTRUSION, TIGHTEN ALL SETSCREWS AND LOCKS TO PREVENT LOSS DURING SHIPPING

Top View of each Level

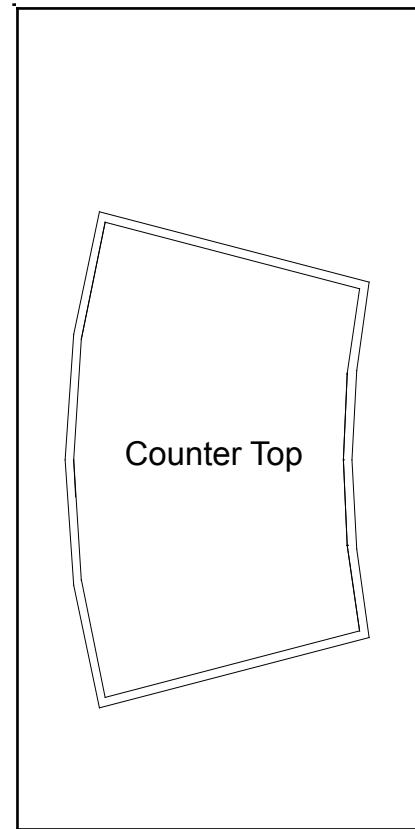

Level 1

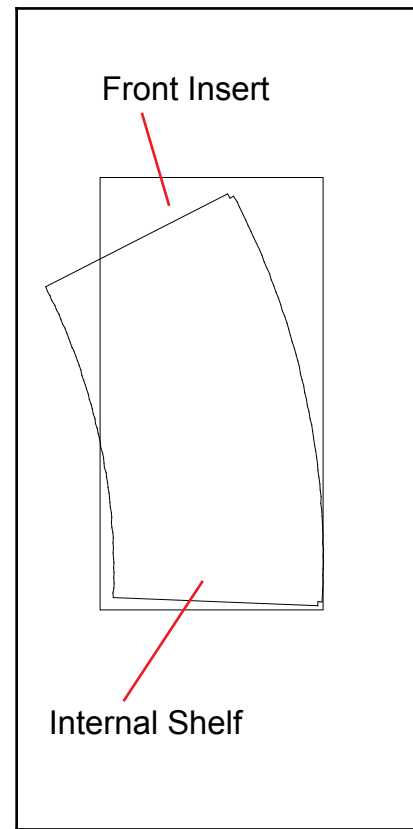

Level 4

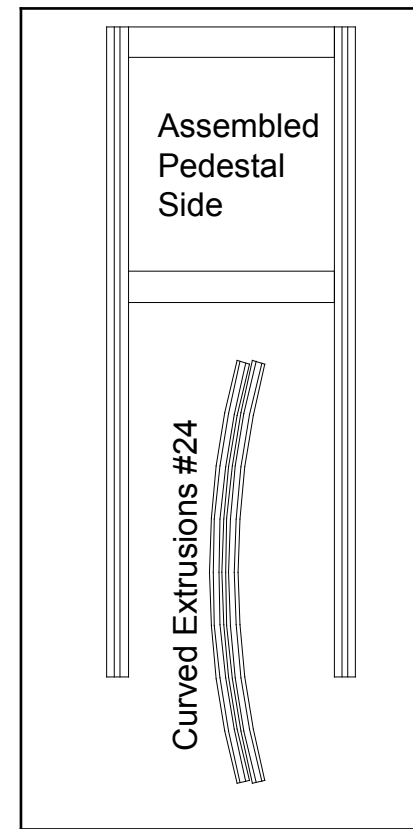

Level 2

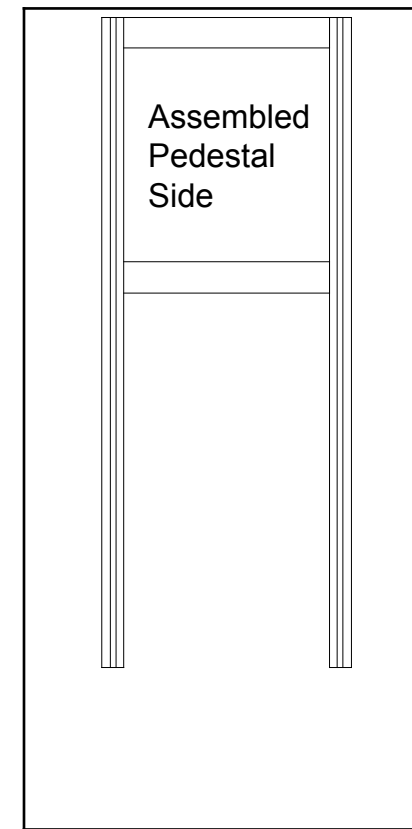

Level 3

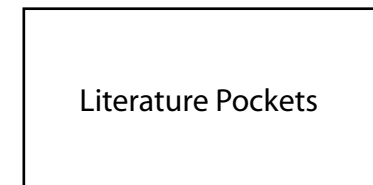

WHEN DISASSEMBLING ALUMINUM EXTRUSION, TIGHTEN ALL SETSCREWS AND LOCKS TO PREVENT LOSS DURING SHIPPING