

Plan View

10'

10'

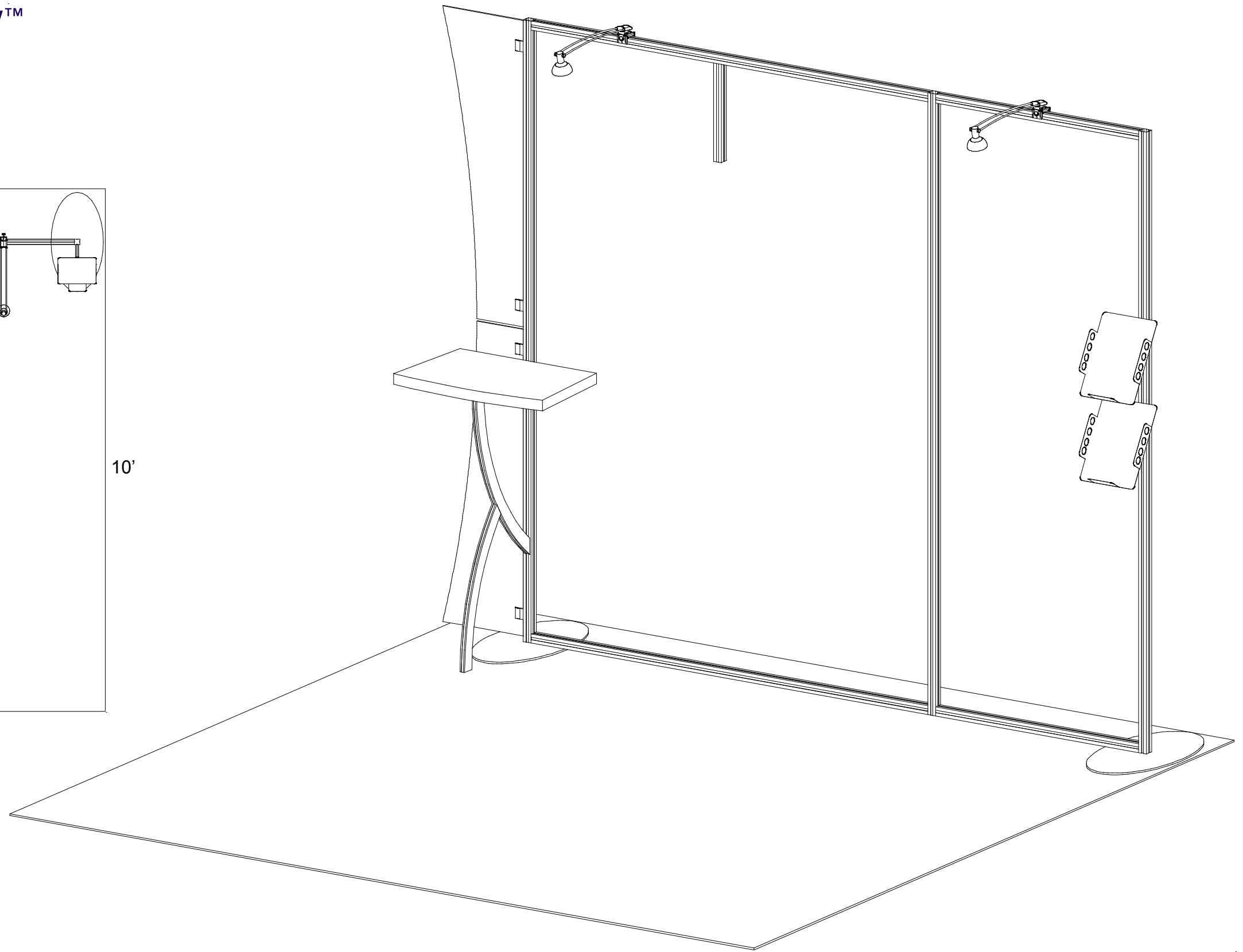

WHEN DISASSEMBLING ALUMINUM EXTRUSION, TIGHTEN ALL SETSCREWS AND LOCKS TO PREVENT LOSS DURING SHIPPING

visionary™ DESIGNS

Using Your Setup Instructions

The Visionary Designs Setup Instructions are created specifically for your configuration. They are laid out sequentially, including an exploded view of the entire display, and then a logical series of detailed steps to assemble the main structure and components. We encourage you to study the instructions **before** attempting to assemble your exhibit.

Each page reminds you to tighten the setscrews after disassembling your exhibit to prevent loss of the locks and setscrews (see below in RED). This is **VERY IMPORTANT**.

Cleaning and Packing Your Display

- 1) Use care when cleaning aluminum extrusion or acrylic inserts. Use only non-abrasive cleaners.
- 2) When cleaning laminate inserts or countertops, use mild cleansers and a soft material such as cotton.
- 3) Keep all display components away from extreme heat and long exposure to sunlight to avoid warping and fading.
- 4) Retain all packing material. It will make re-packing much easier and will reduce the likelihood of shipping damage.



The Tool

Most Visionary Designs exhibits can be assembled with the supplied Hex Key Tool. Occasionally, a flat head screwdriver may be required.



Typical Connection

Most horizontal extrusion connections have a patented expandable lock. This lock inserts into the groove of an opposing extrusion. Tightening the lock with the Hex Key Tool expands the lock and creates a strong positive connection.



Typical Connection (cont'd)

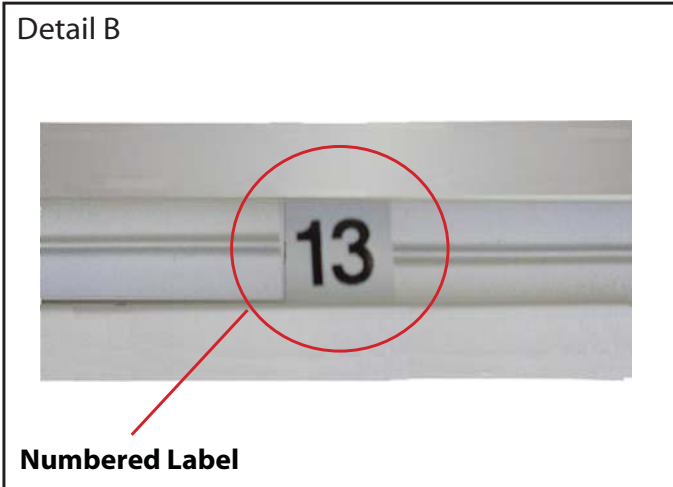

Detail B

Numbered Label

Each extrusion contains a numbered label which corresponds with setup instructions. The label is located within a groove of the extrusion (when possible). With Visionary Designs the labels contain Black numbers unless otherwise specified.



Detail C

Horizontal Inline Connection (remove only one setscrew)

Remove only (1) setscrew when disassembling. Replace setscrew in extrusion after assembling it. Before packing, replace setscrew in extrusion to avoid losing it.

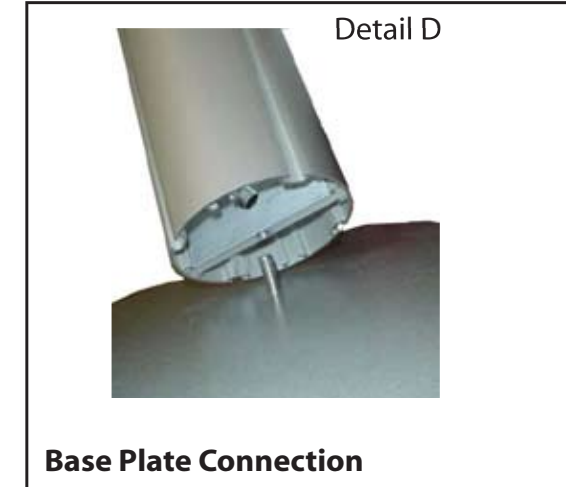

Detail D

Base Plate Connection

Attach base plate to round or square vertical extrusion using the bolt provided. Be careful not to strip the threads.

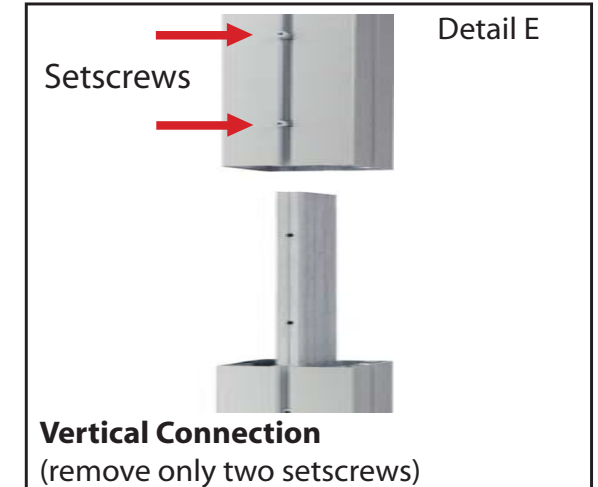

Detail E

Vertical Connection
(remove only two setscrews)

When vertical extrusions are packed in portable cases rather than crates or tubs, they must be broken down into smaller sections which then require assembly.

Remove only (2) setscrews when disassembling. Replace setscrews in extrusion after assembling it. Before packing, replace setscrews in extrusion to avoid losing them.

WHEN DISASSEMBLING ALUMINUM EXTRUSION, TIGHTEN ALL SETSCREWS AND LOCKS TO PREVENT LOSS DURING SHIPPING

866.652.2100

Item	Qty.	Description
1	2	Base Plate
2a/2b/2c	1/1/1	43.875" h Lower Square Vertical Extrusion
3a/3b/3c	1/1/1	43.875" h Upper Square Vertical Extrusion
4a/4b	1/1	31.98" w Lower Square Horizontal Extrusion
4c	1	32.75" w Lower Square Horizontal Extrusion
5a/5b	1/1	31.98" w Upper Square Horizontal Extrusion
5c	1	32.75" w Upper Square Horizontal Extrusion

Steps:

- 1) Attach vertical extrusions [2a and 2c] to base plates [1]. Refer to general info. page.
- 2) Attach upper vertical extrusions [3a, 3b, and 3c] to lower vertical extrusions [2a, 2b, and 2c]. Refer to general info. page.
- 3) Connect horizontal extrusions [4a to 4b and 5a to 5b] together. Refer to general info. page.
- 4) Attach horizontal assemblies [4a/4b and 5a/5b] and horizontal extrusions [4c and 5c] between vertical assemblies as shown. Attach graphic header support. Refer to general info. page.
- 6) Apply graphic to back of assembled backwall. Apply graphic header to upper backwall.

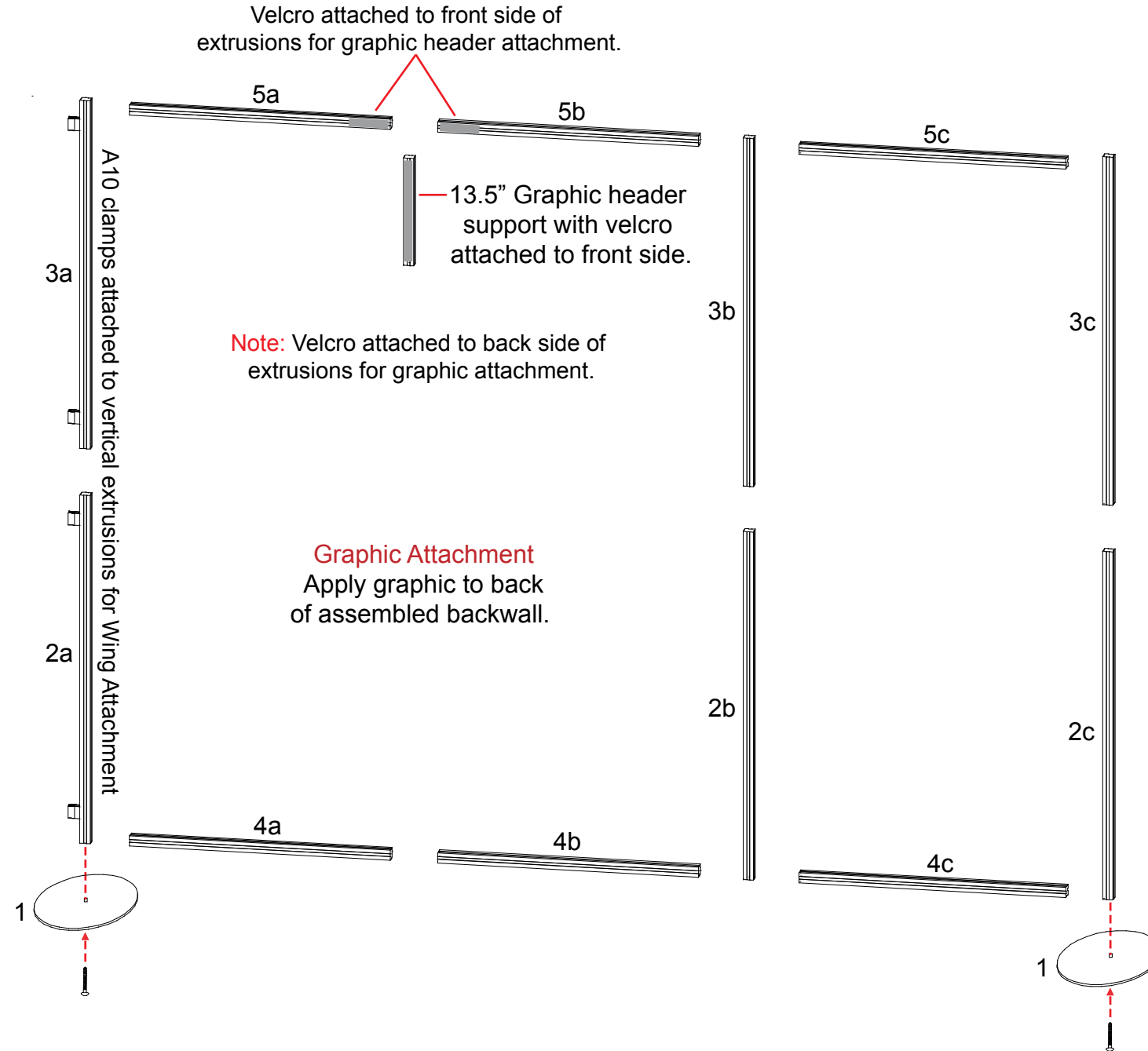
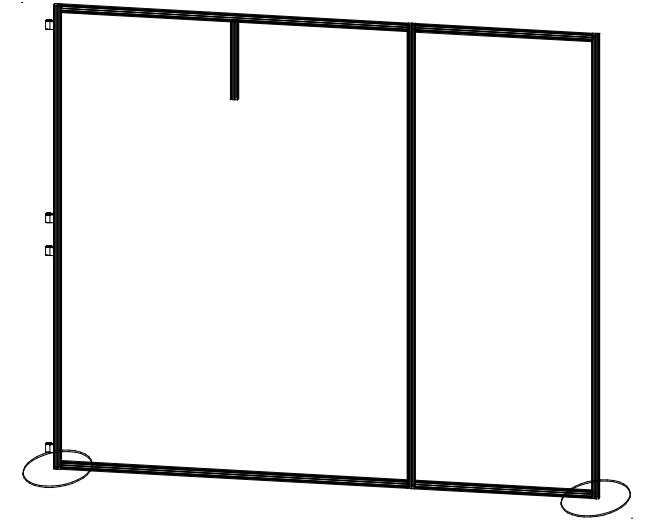

WHEN DISASSEMBLING ALUMINUM EXTRUSION, TIGHTEN ALL SETSCREWS AND LOCKS TO PREVENT LOSS DURING SHIPPING

866.652.2100

*** Monitor Mount Attachment**

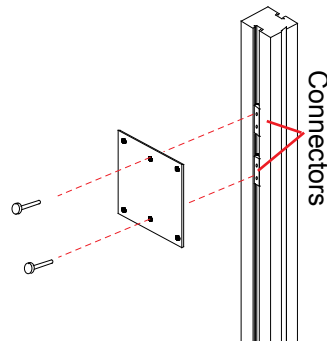

Attach monitor mount back plate to connectors using screws provided.

Steps:

- 1) Attach counter support assembly [10/11] to vertical where indicated.
- 2) Connect leg support [10a] to counter support assembly [10/11] as shown.
- 3) Attach flange plate [11a] to top of curved extrusion [10] as shown.
- 4) Attach counter atop support, see counter top attachment detail.
- 5) Attach wing panels to A10 clips, see wing attachment detail.
- 6) Attach monitor mount to backwall where indicated.
- 7) Attach literature racks, see literature rack attachment detail.
- 8) Attach Lights atop backwall, see light connection detail.
- 9) Velcro graphic header to upper back wall as shown.

Item	Qty.	Description
10	1	30.2" Curved Extrusion
10a	1	Leg Support
11	1	12.184"w Horizontal Extrusion
11a	1	Flange Plate

Wing Attachment

Slide A10 Clamp into groove of square extrusion.

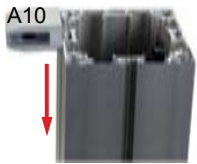

When desired location is found, tighten set screw to secure.

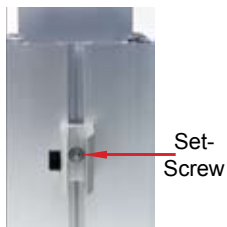

Tighten knob to secure Wing in place.

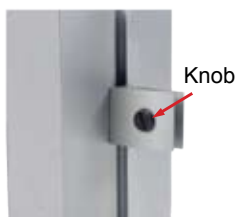

**Note: A10 clamps must stay attached with verticals*

Light Connection

Attach Lights to Backwall where desired and tighten in place.

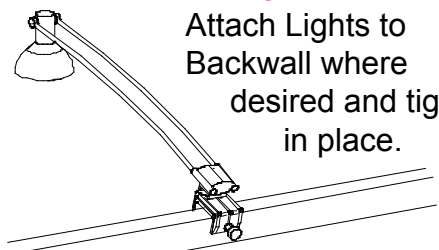

Counter Top Attachment

Insert screws located on underside of counter into holes on flange plate and secure with wing nuts.

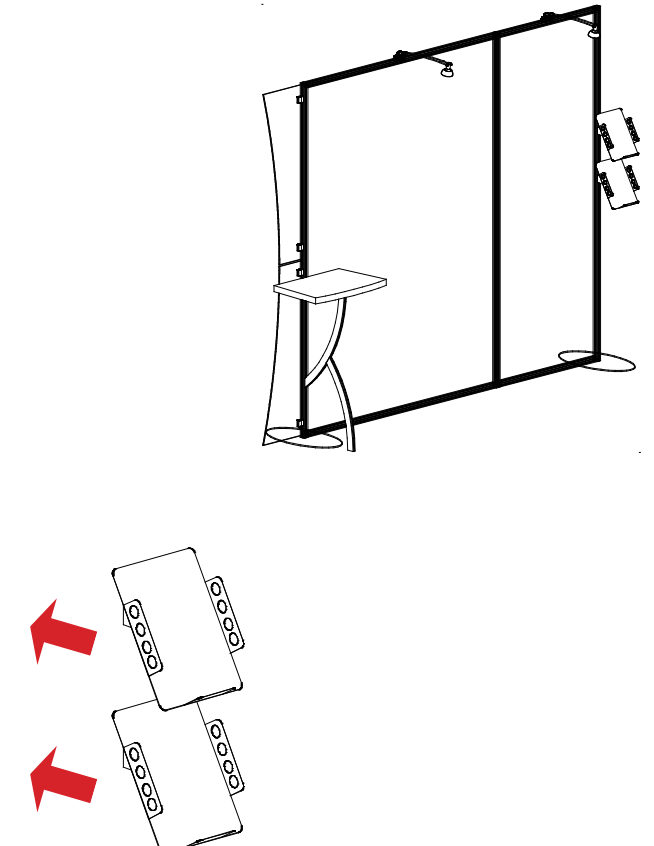
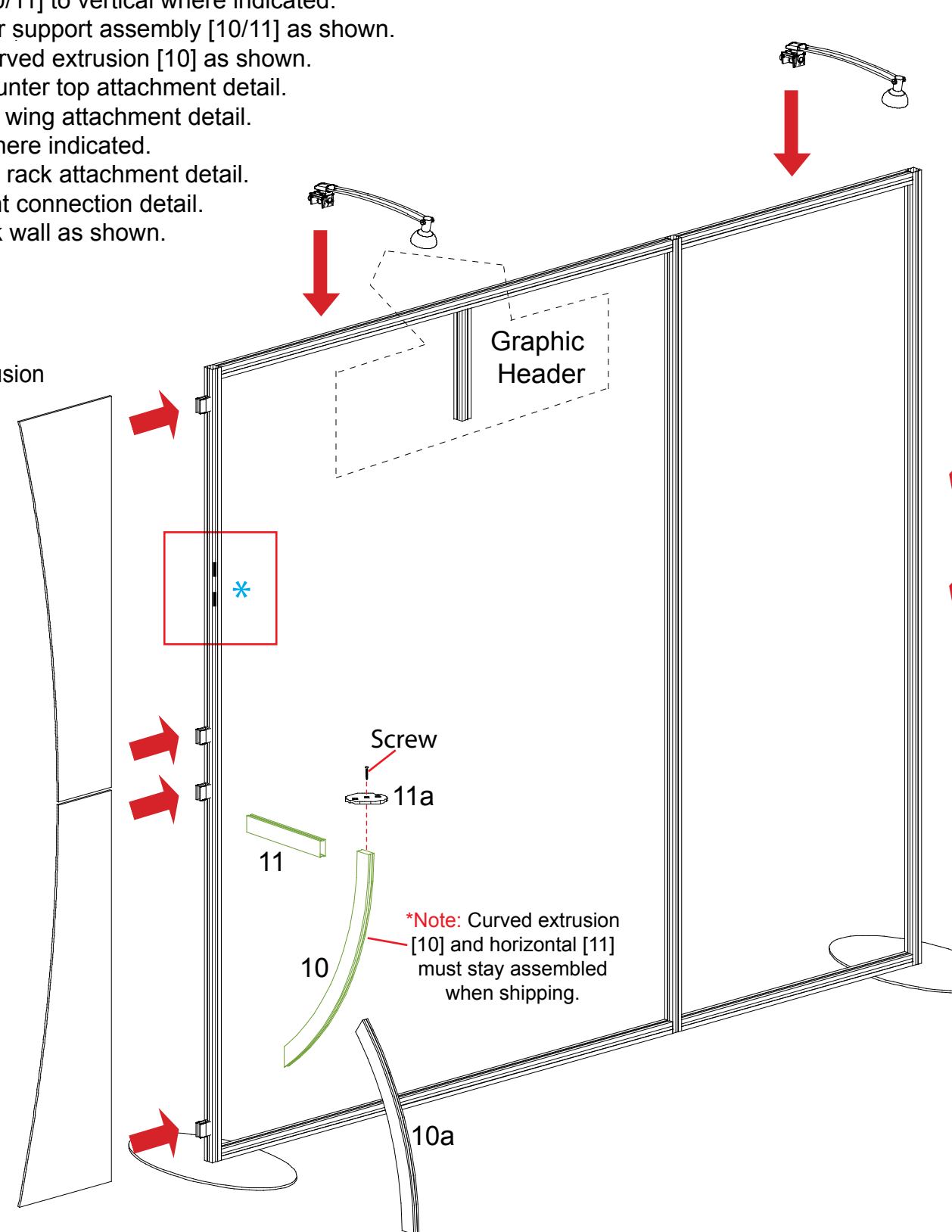
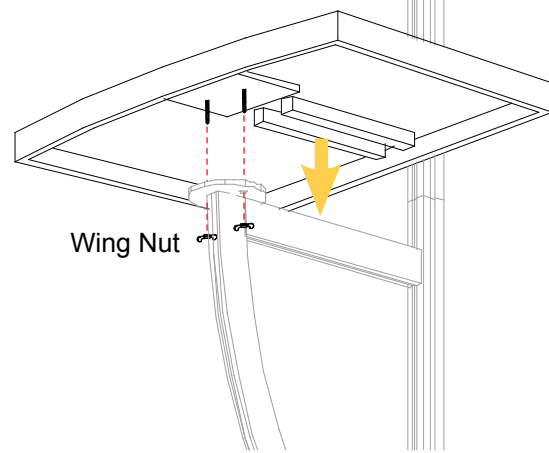

Literature Rack Attachment

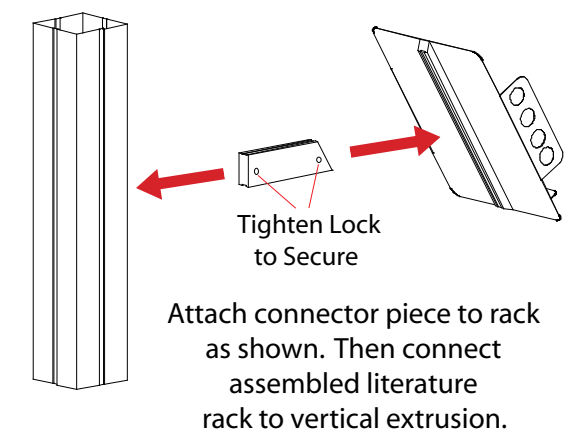

WHEN DISASSEMBLING ALUMINUM EXTRUSION, TIGHTEN ALL SETSCREWS AND LOCKS TO PREVENT LOSS DURING SHIPPING

(1) Backwall Components

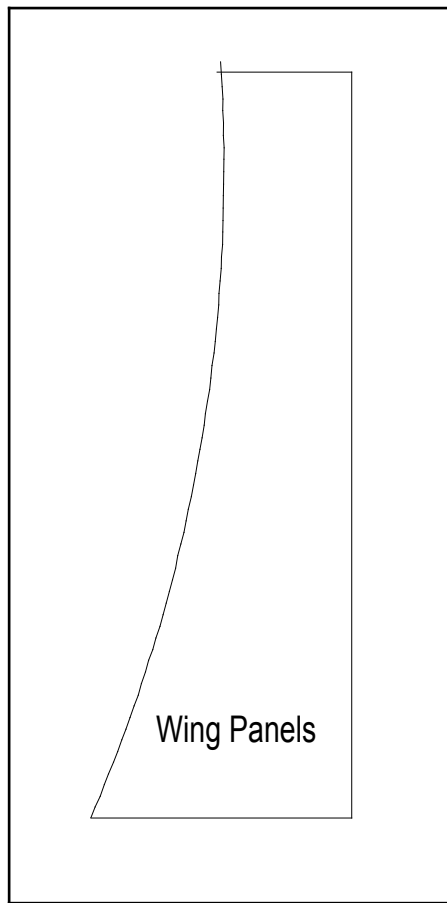

Level 1

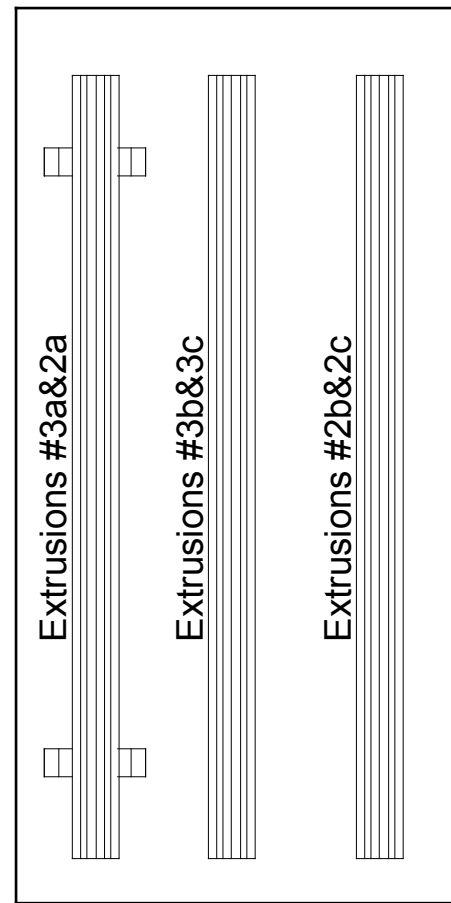

Level 2

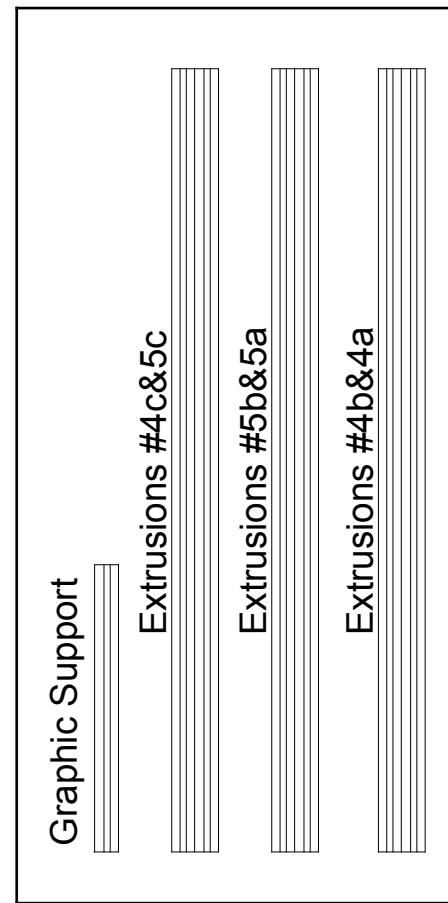

Level 3

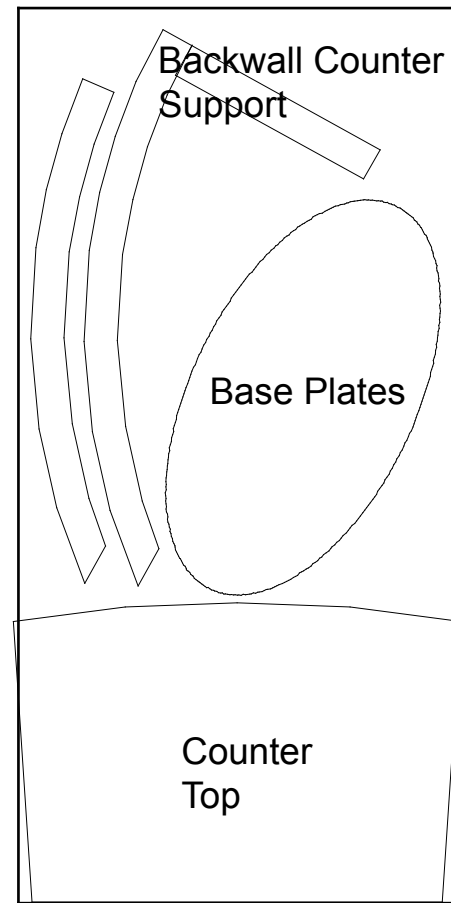

Level 4

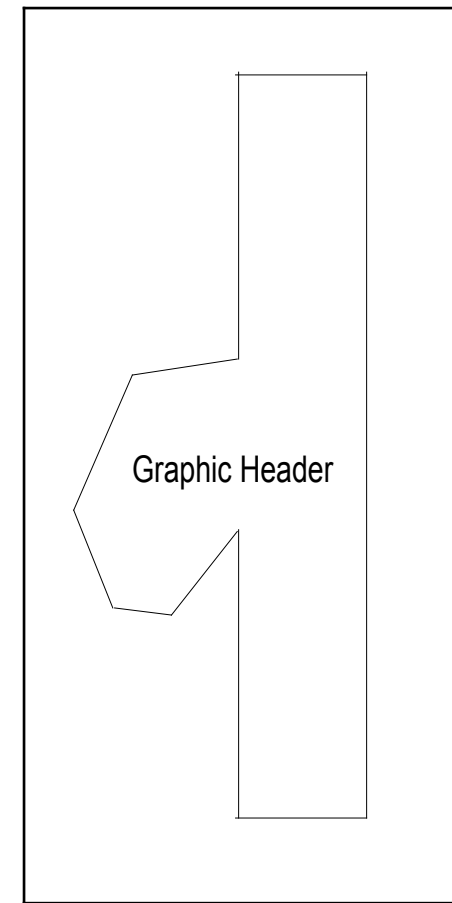

Level 5

- Setup Hardware
- Lights
- Graphics
- Literature Pockets

WHEN DISASSEMBLING ALUMINUM EXTRUSION, TIGHTEN ALL SETSCREWS AND LOCKS TO PREVENT LOSS DURING SHIPPING