

visionaryTM
MAGELLAN DESIGNS

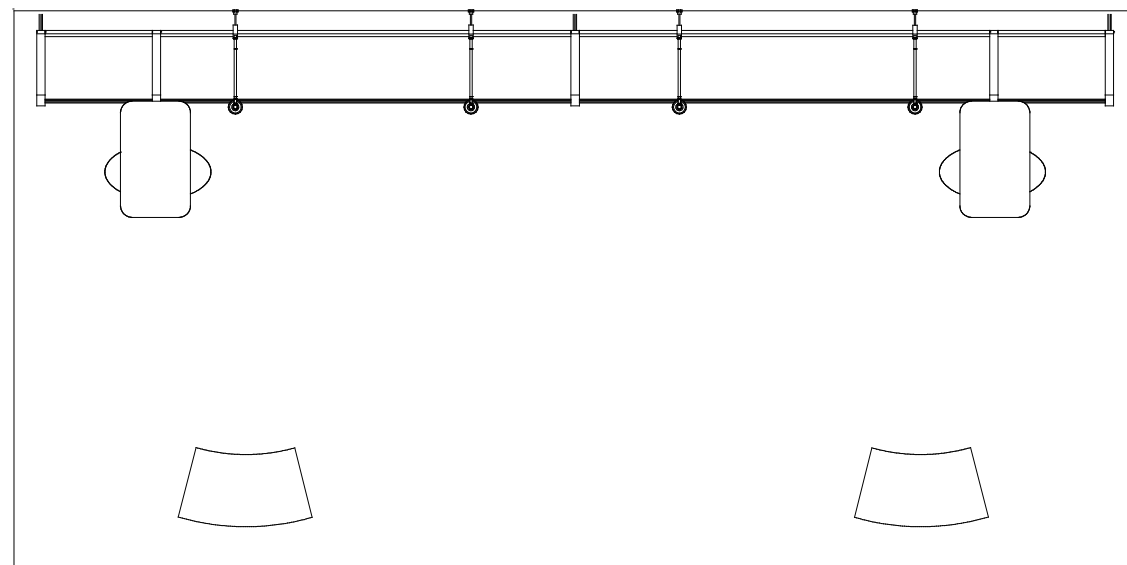
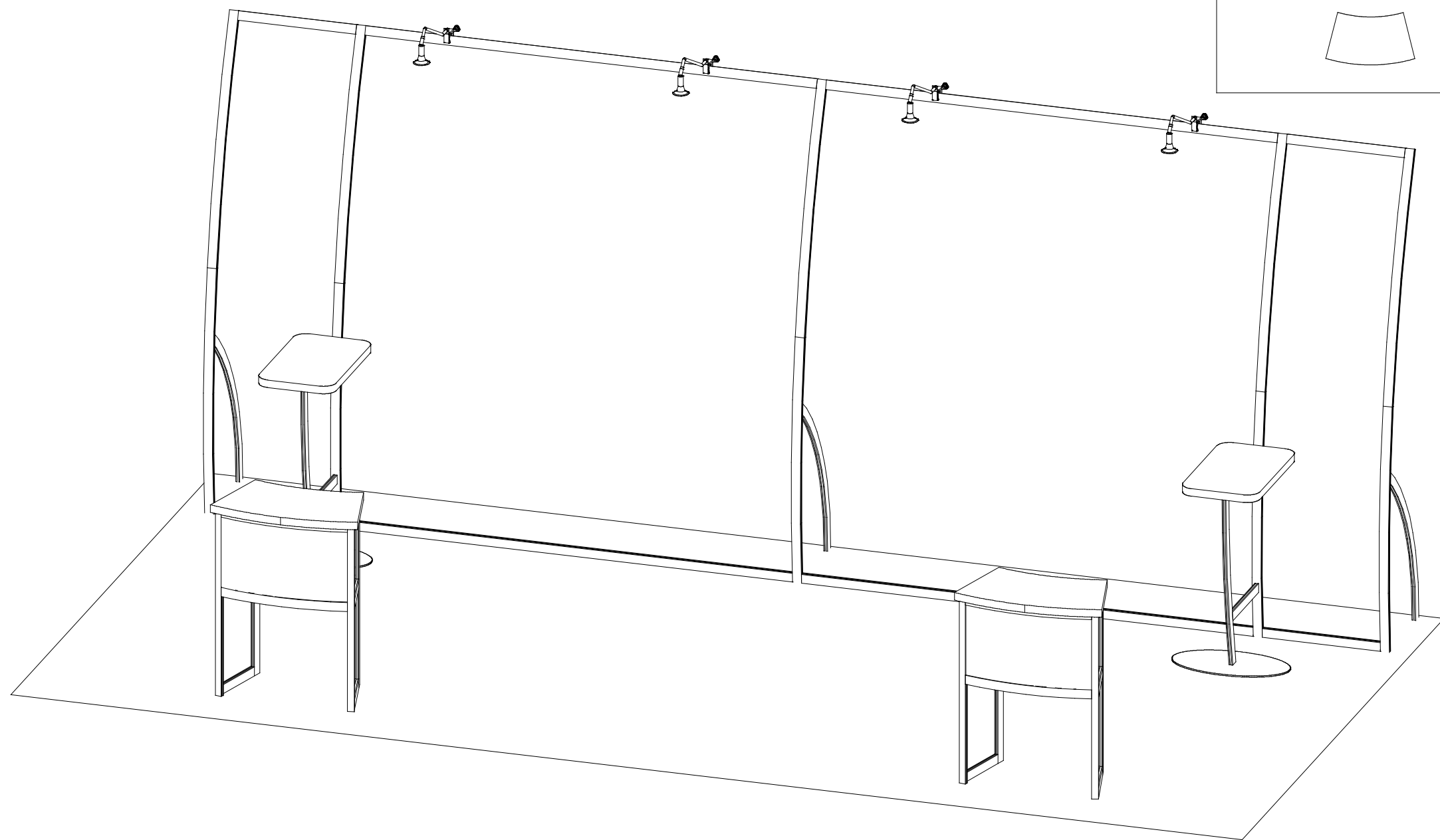

20'

Plan View

10'

WHEN DISASSEMBLING ALUMINUM EXTRUSION, TIGHTEN ALL SETSCREWS AND LOCKS TO PREVENT LOSS DURING SHIPPING

visionary™ DESIGNS

Using Your Setup Instructions

The Visionary Designs Setup Instructions are created specifically for your configuration. They are laid out sequentially, including an exploded view of the entire display, and then a logical series of detailed steps to assemble the main structure and components. We encourage you to study the instructions **before** attempting to assemble your exhibit.

Each page reminds you to tighten the setscrews after disassembling your exhibit to prevent loss of the locks and setscrews (see below in RED). This is **VERY IMPORTANT**.

Cleaning and Packing Your Display

- 1) Use care when cleaning aluminum extrusion or acrylic inserts. Use only non-abrasive cleaners.
- 2) When cleaning laminate inserts or countertops, use mild cleansers and a soft material such as cotton.
- 3) Keep all display components away from extreme heat and long exposure to sunlight to avoid warping and fading.
- 4) Retain all packing material. It will make re-packing much easier and will reduce the likelihood of shipping damage.



The Tool

Most Visionary Designs exhibits can be assembled with the supplied Hex Key Tool. Occasionally, a flat head screwdriver may be required.



Detail A

Typical Connection



Typical Connection (cont'd)

Most horizontal extrusion connections have a patented expandable lock. This lock inserts into the groove of an opposing extrusion. Tightening the lock with the Hex Key Tool expands the lock and creates a strong positive connection.

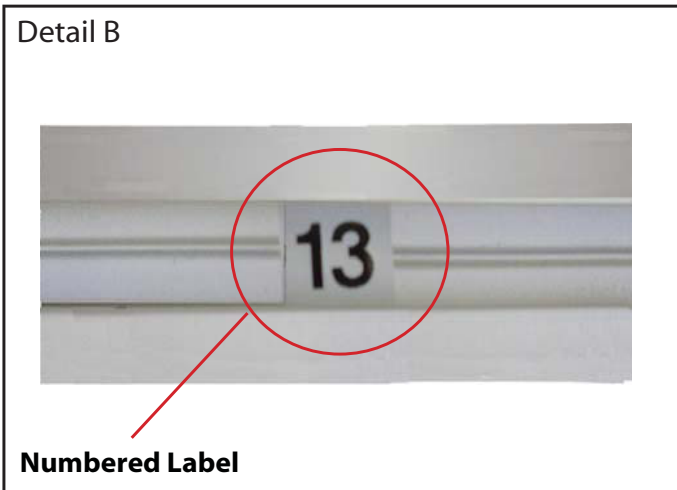

Detail B

Numbered Label

Each extrusion contains a numbered label which corresponds with setup instructions. The label is located within a groove of the extrusion (when possible). With Visionary Designs the labels contain Black numbers unless otherwise specified.



Detail C

Horizontal Inline Connection (remove only one setscrew)

Remove only (1) setscrew when disassembling. Replace setscrew in extrusion after assembling it. Before packing, replace setscrew in extrusion to avoid losing it.

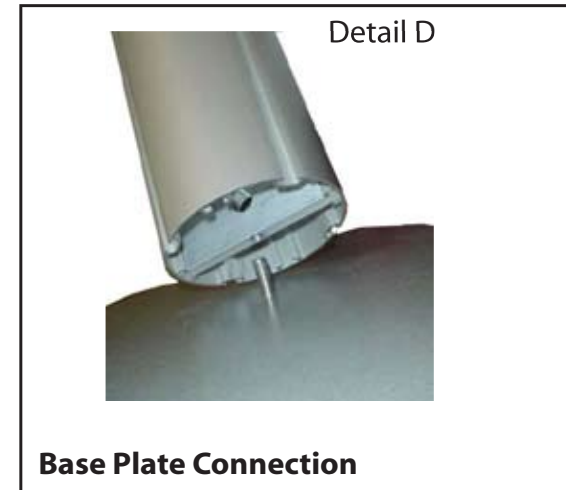

Detail D

Base Plate Connection

Attach base plate to round or square vertical extrusion using the bolt provided. Be careful not to strip the threads.



Detail E

Vertical Connection
(remove only two setscrews)

When vertical extrusions are packed in portable cases rather than crates or tubs, they must be broken down into smaller sections which then require assembly.

Remove only (2) setscrews when disassembling. Replace setscrews in extrusion after assembling it. Before packing, replace setscrews in extrusion to avoid losing them.

WHEN DISASSEMBLING ALUMINUM EXTRUSION, TIGHTEN ALL SETSCREWS AND LOCKS TO PREVENT LOSS DURING SHIPPING

Part Number	Qty	Description
1	1	48.5" h Lower Curved Extrusion
2	1	48.5" h Upper Curved Extrusion
3	1	48.5" h Lower Curved Extrusion
4	1	48.5" h Upper Curved Extrusion
5	1	48.5" h Lower Curved Extrusion
6	1	48.5" h Upper Curved Extrusion
7	1	23" w Horizontal Extrusion
8	1	23" w Horizontal Extrusion
9a/9b	1/1	44" w Horizontal Extrusion
10a/10b	1/1	44" w Horizontal Extrusion
11	1	Backwall Support Leg Extrusion
12	1	Backwall Support Leg Extrusion

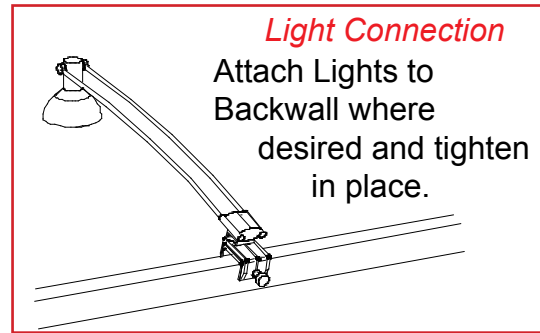

GREEN STAR indicates location of connection lock with knob.

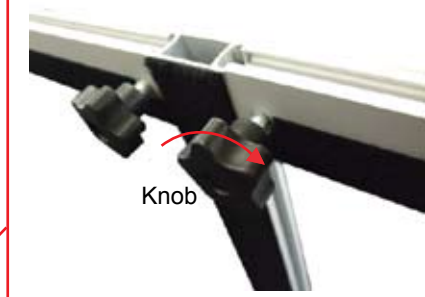

Do not over tighten Knobs.

Steps

Unit can be assembled face down on the floor then lifted upright.

- 1) Connect backwall upper and lower verticals together [1 to 2, 3 to 4 and 5 to 6].
- 2) Connect horizontal extrusions together [9a to 9b and 10a to 10b].
- 3) Attach horizontal assemblies [7 and 8] between vertical assemblies [1/2 and 3/4].
- 4) Attach horizontal extrusions [9a/9b and 10a/10b] between vertical assemblies [3/4 and 5/6].
- 5) Attach support leg extrusions [11 and 12] to back of verticals [1 and 5], see leg attachment detail.

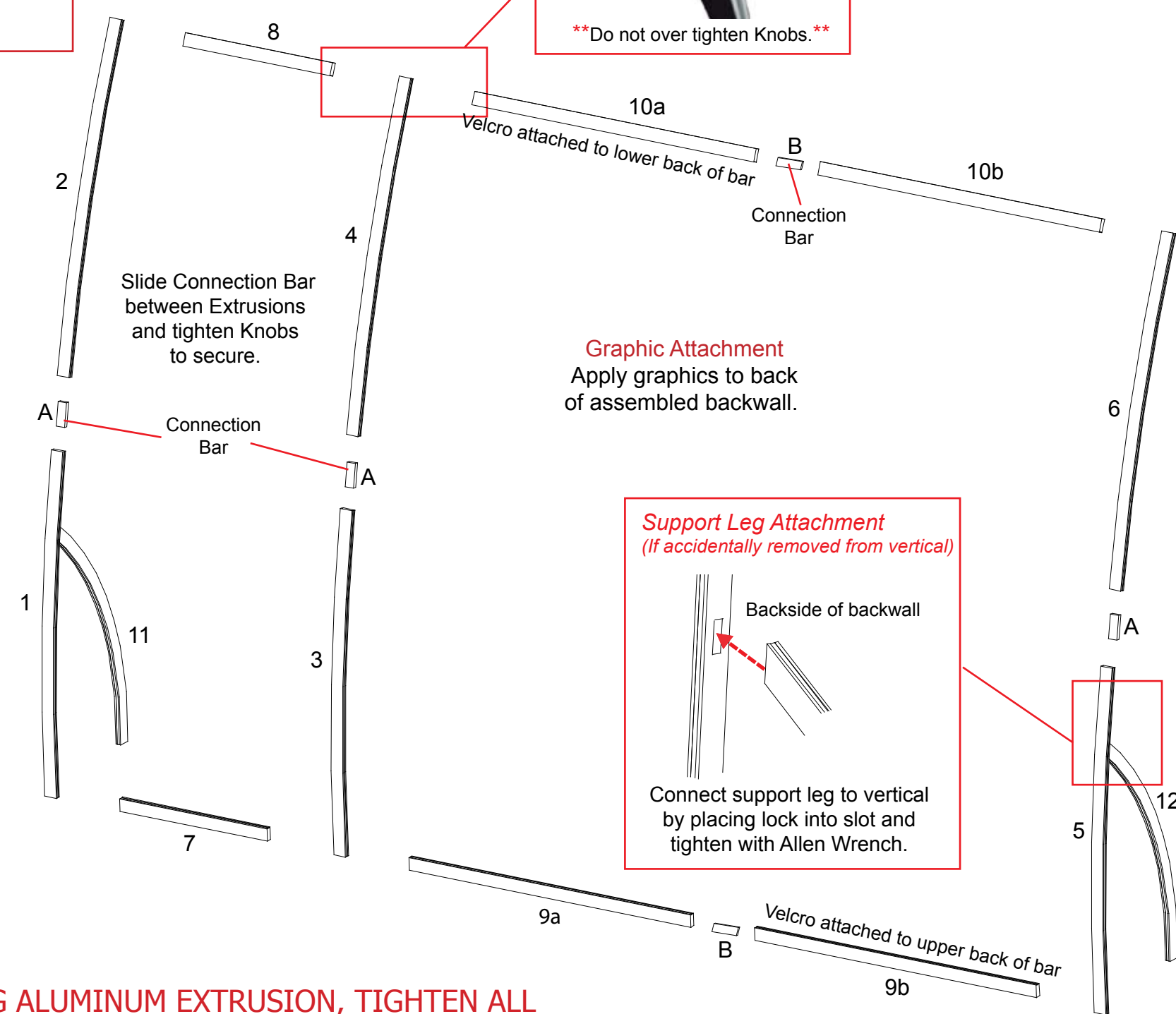

STAR indicates location of knobs on BACKSIDE of unit.

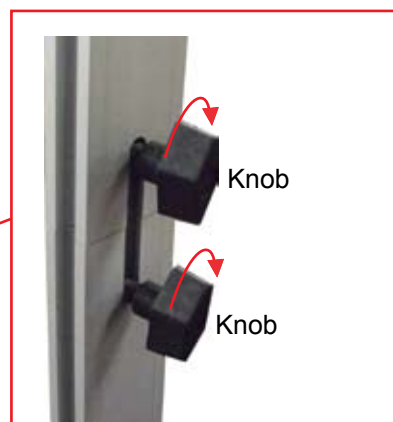
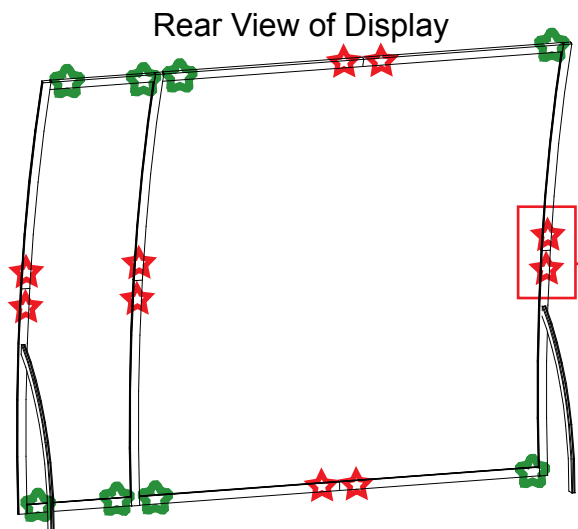

Do not over tighten Knobs.

WHEN DISASSEMBLING ALUMINUM EXTRUSION, TIGHTEN ALL SETSCREWS AND LOCKS TO PREVENT LOSS DURING SHIPPING

866.652.2100

Part Number	Qty	Description
13	1	48.5" h Lower Curved Extrusion
14	1	48.5" h Upper Curved Extrusion
15	1	48.5" h Lower Curved Extrusion
16	1	48.5" h Upper Curved Extrusion
17a/17b	1/1	44" w Horizontal Extrusion
18a/18b	1/1	44" w Horizontal Extrusion
19	1	23" w Horizontal Extrusion
20	1	23" w Horizontal Extrusion
21	1	Backwall Support Leg Extrusion

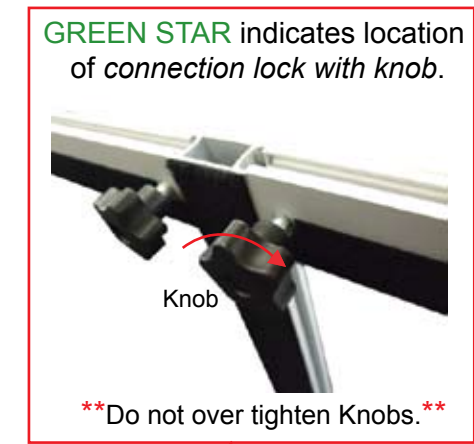
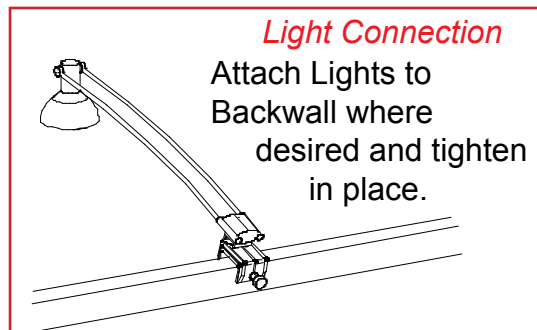

- Steps
- 1) Connect backwall upper and lower verticals together [13 to 14 and 15 to 16].
 - 2) Connect horizontal extrusions together [17a to 17b and 18a to 18b].
 - 3) Attach horizontal assemblies [17a/17b and 18a/18b] between vertical assemblies [5/6 and 13/14].
 - 4) Attach horizontal extrusions [19 and 20] between vertical assemblies [13/14 and 15/16].
 - 5) Attach support leg extrusions [21] to back of verticals [15], see leg attachment detail.
 - 6) Attach monitor mount to upper vertical [14].

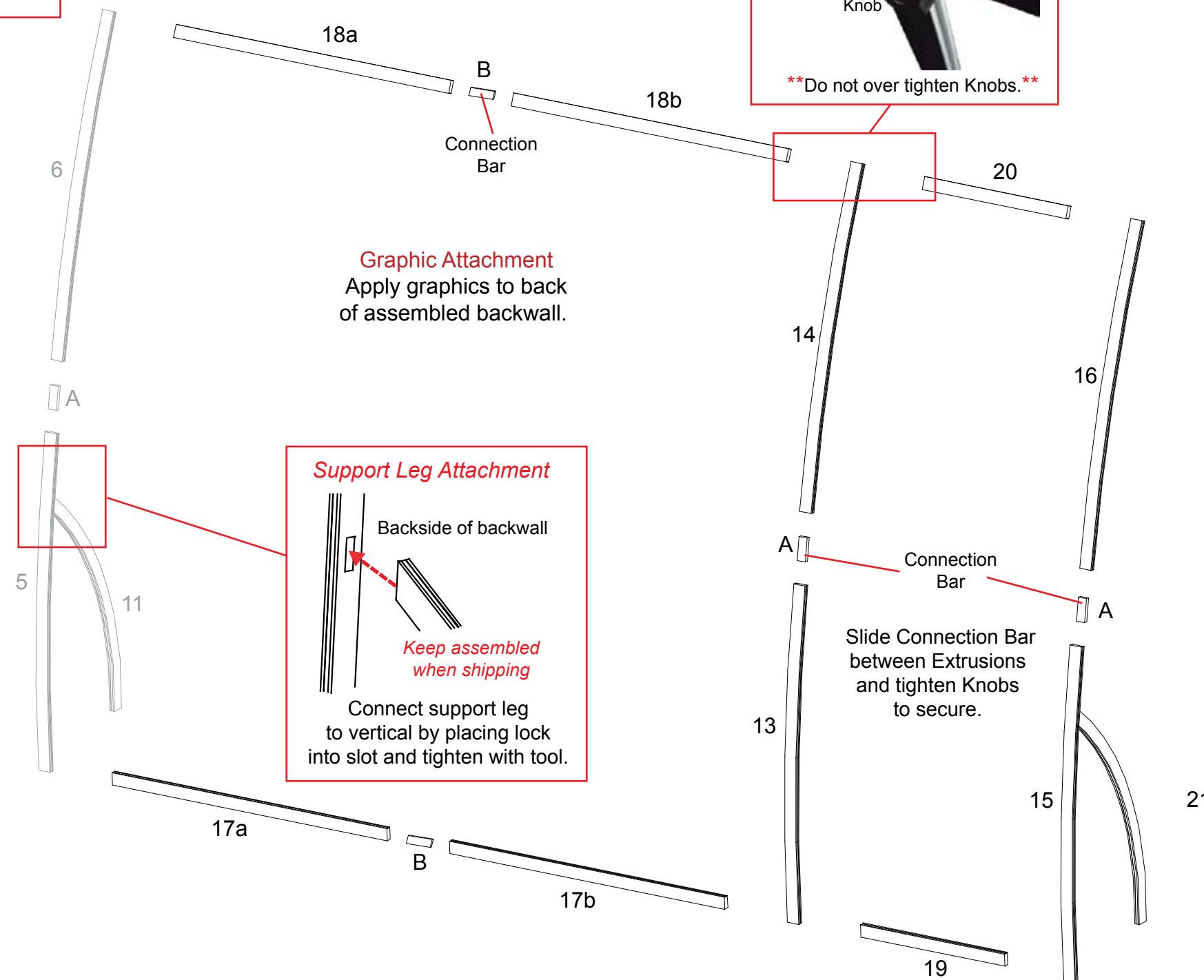
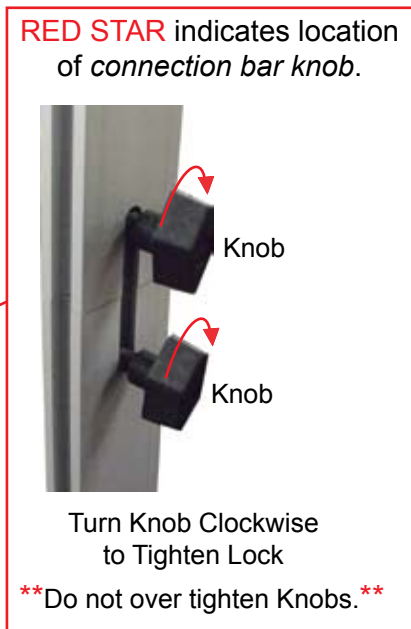
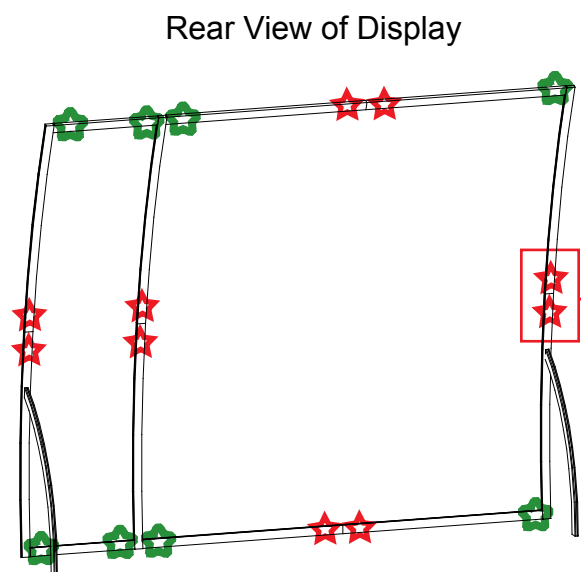

Graphic Attachment
Apply graphics to back of assembled backwall.

Support Leg Attachment
Backside of backwall
Keep assembled when shipping
Connect support leg to vertical by placing lock into slot and tighten with tool.

Slide Connection Bar between Extrusions and tighten Knobs to secure.

WHEN DISASSEMBLING ALUMINUM EXTRUSION, TIGHTEN ALL SETSCREWS AND LOCKS TO PREVENT LOSS DURING SHIPPING

866.652.2100

Part Number	Qty	Description
22	2	Base Plate
23	2	37.6" h Curved Vertical Extrusion
23a	2	Oval Flange Plate
24	2	18.5" w Horizontal Extrusion
25	2	15.69" w Horizontal Extrusion

Steps

- 1) Attach curved vertical [23] to base plate [22], see Base Plate Attachment detail.
- 2) Attach horizontal extrusions [24 and 25] between curved verticals [23] and backwall verticals [3 and 13] where indicated.
- 3) Attach flange plate to top of verticals [23] as shown.
- 4) Place counter tops on assembled counter base, see Counter Attachment detail.

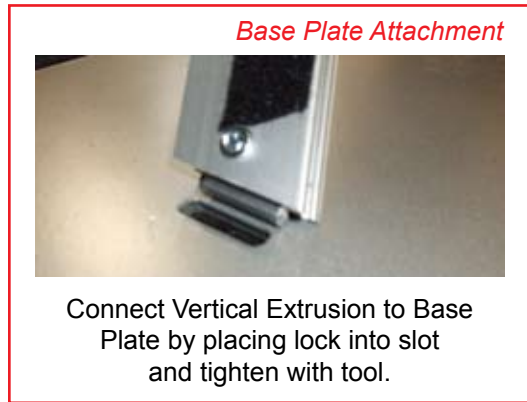
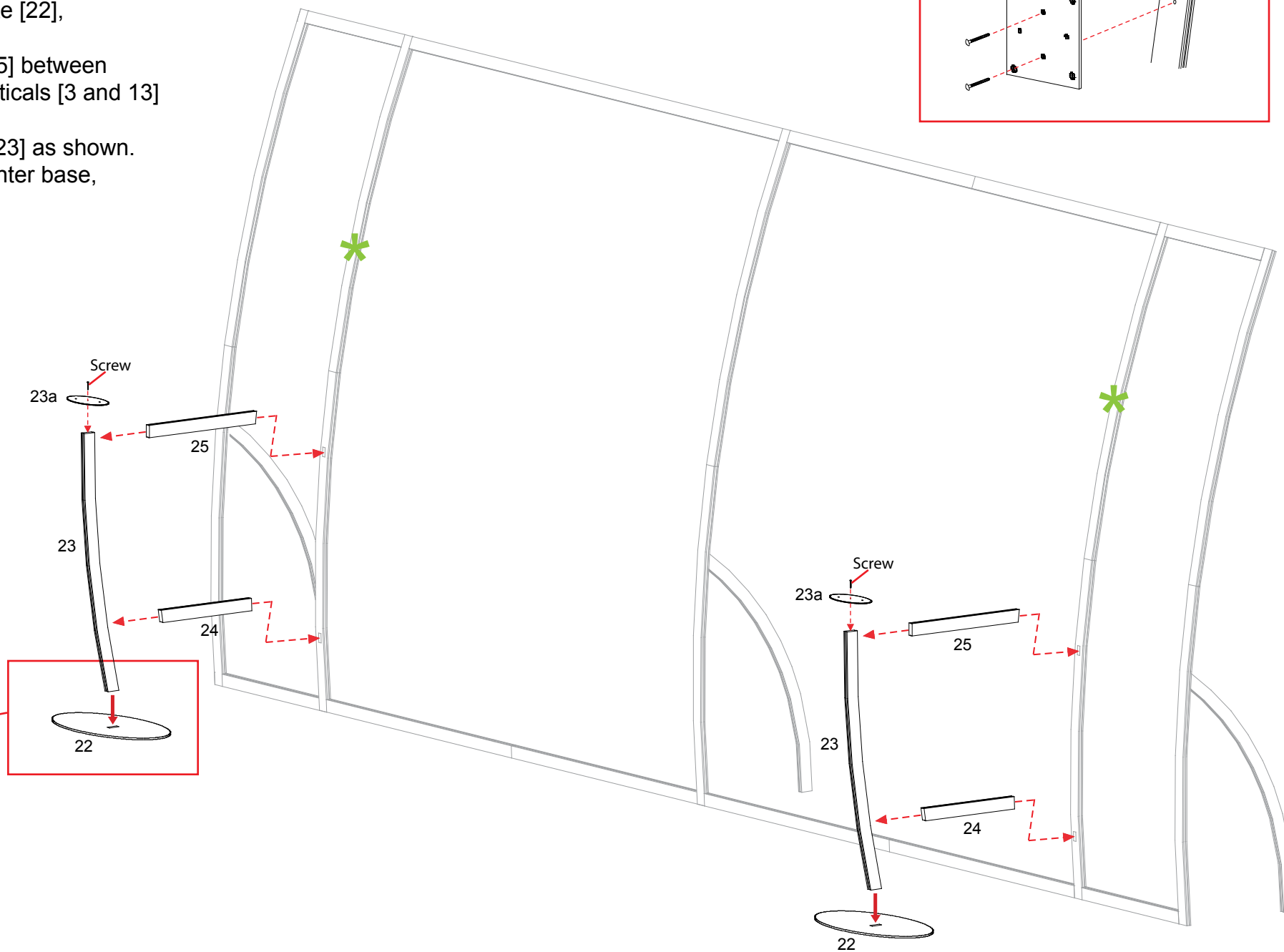
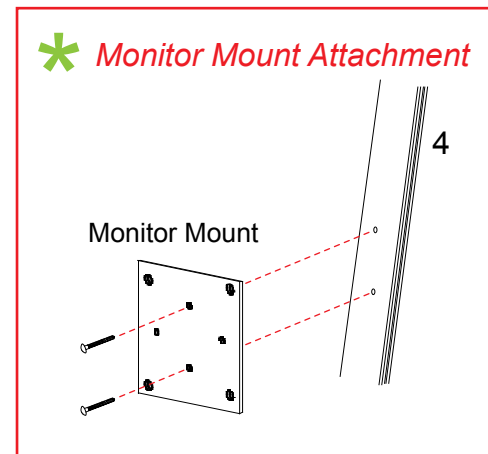

Counter Top Attachment

Insert screws located on underside of counter into holes on flange plate and secure with wing nuts.

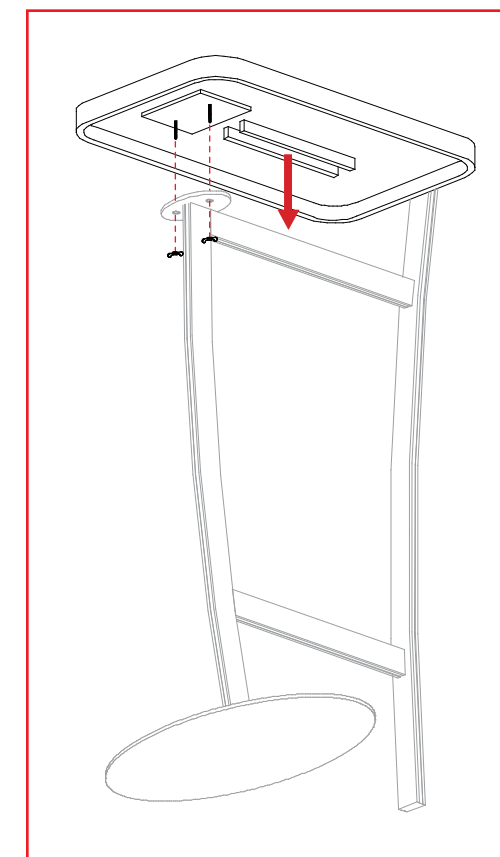

WHEN DISASSEMBLING ALUMINUM EXTRUSION, TIGHTEN ALL SETSCREWS AND LOCKS TO PREVENT LOSS DURING SHIPPING

866.652.2100

Part Number	Qty	Description
26	1	41.5"h Corner Extrusion w/ Door Hinges
27	1	41.5"h Corner Extrusion
28	1	41.5"h Corner Extrusion
29	1	41.5"h Corner Extrusion w/ Door Stop
31/31a/31b	2/2/2	11"w Horizontal Extrusion
32	2	24.842"w Horizontal Extrusion
33	2	18.534"w Horizontal Extrusion

Steps

1) Attach horizontal extrusions [31, 31a and 31b] between corner extrusions [26&27 and 28&29], placing inserts where indicated, see Top View for extrusion orientation.

Note: Pedestal Sides should remain assembled when shipping.

2) Attach horizontal extrusions [32] between corner extrusions [27 and 28], placing insert between horizontals as shown.

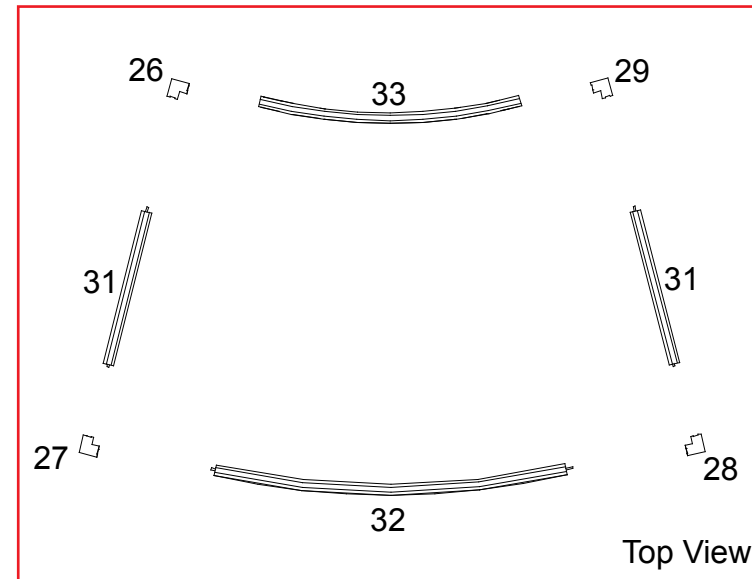

Steps (Cont'd):

- 3) Attach curved horizontal extrusions [33] between corner extrusions [26 and 29], attaching door between curved horizontals, see Door Attachment details.
- 4) Rest shelf atop lips on extrusion [31b].
- 5) Set counter top atop assembled base and secure inside of counter top with thumbscrews.

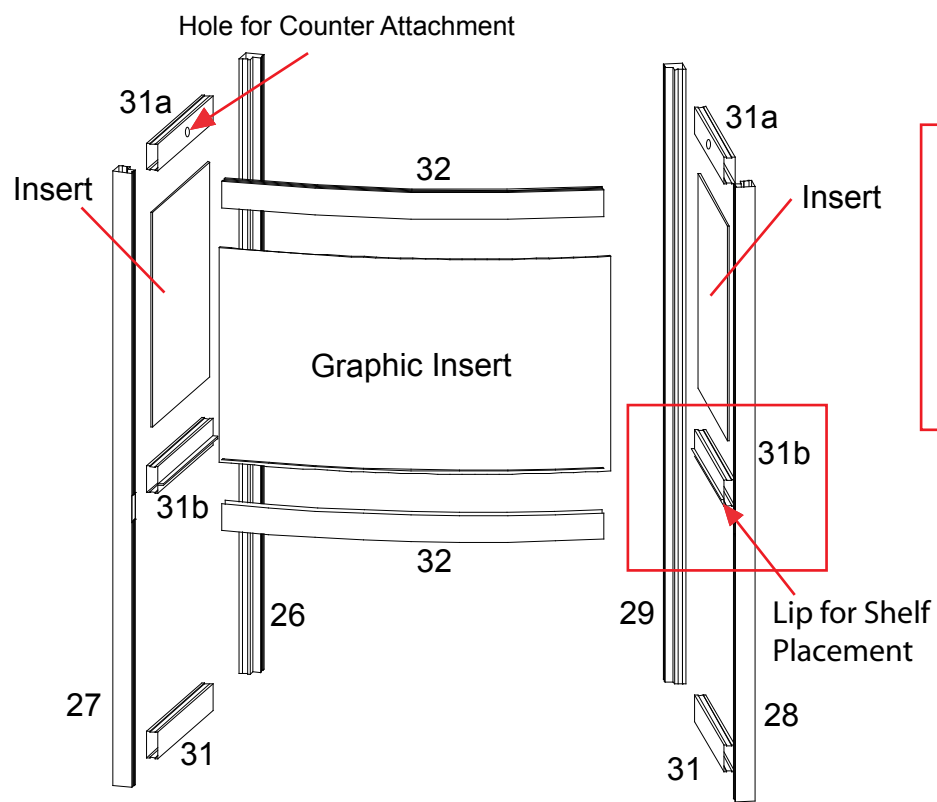
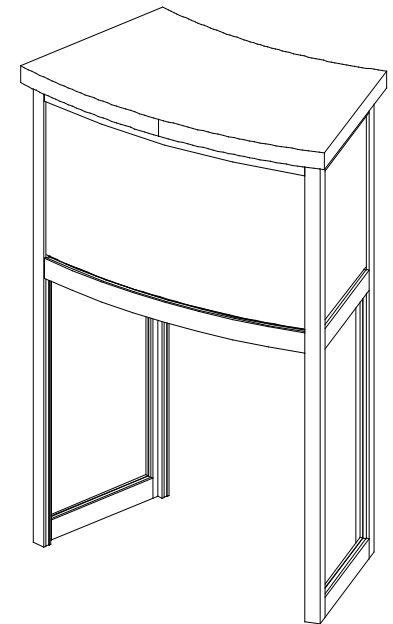

Extrusion Details:
Extrusions 31b have a lip for the floor to rest upon.

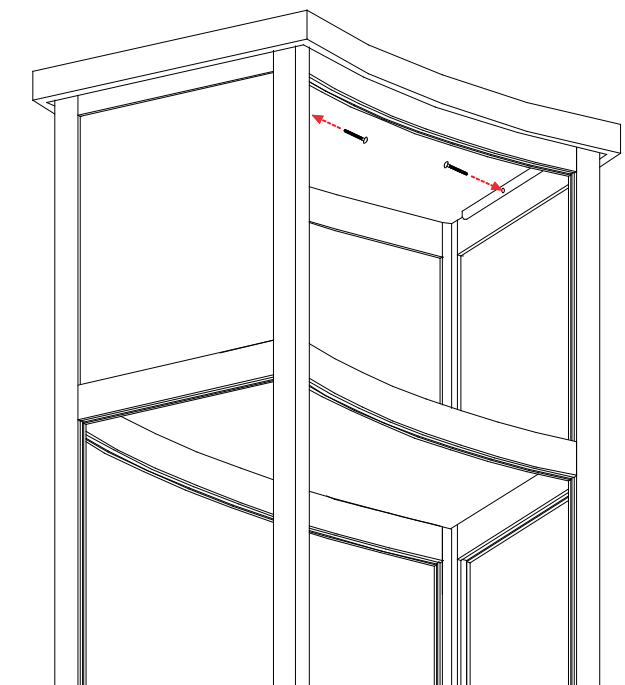
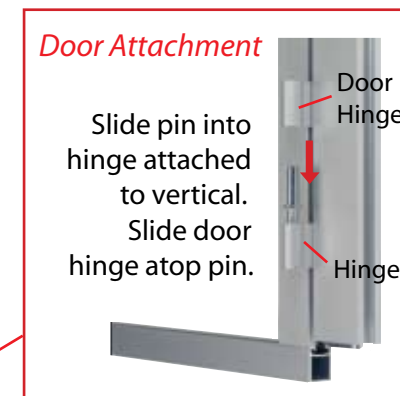
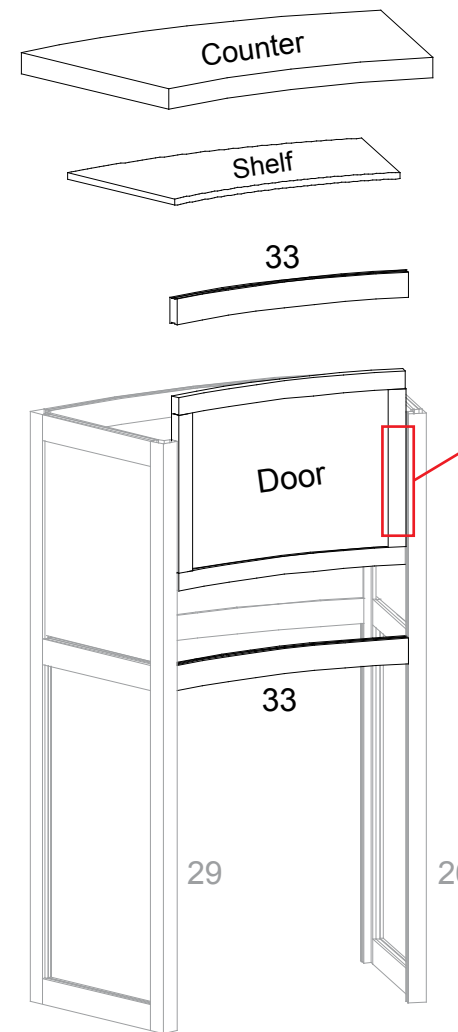

Use door opening to secure counter top using thumbscrews provided.

WHEN DISASSEMBLING ALUMINUM EXTRUSION, TIGHTEN ALL SETSCREWS AND LOCKS TO PREVENT LOSS DURING SHIPPING

866.652.2100

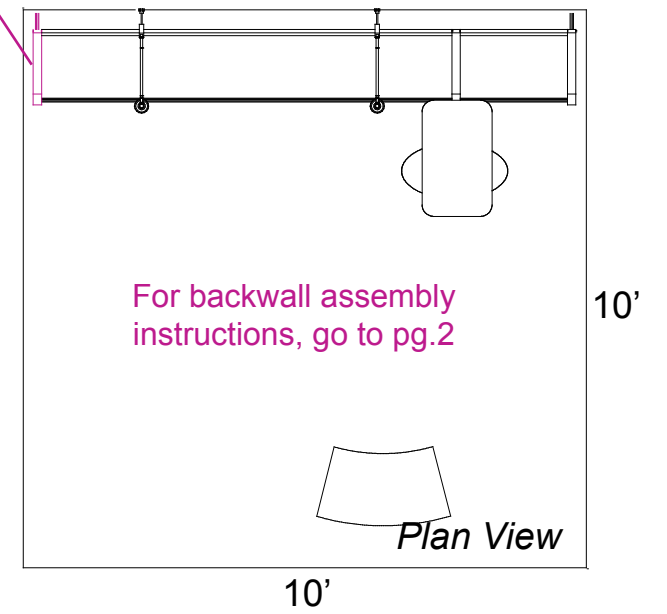
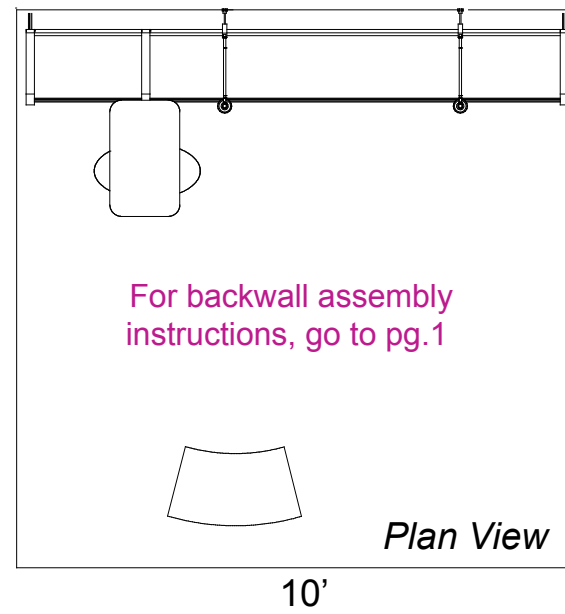
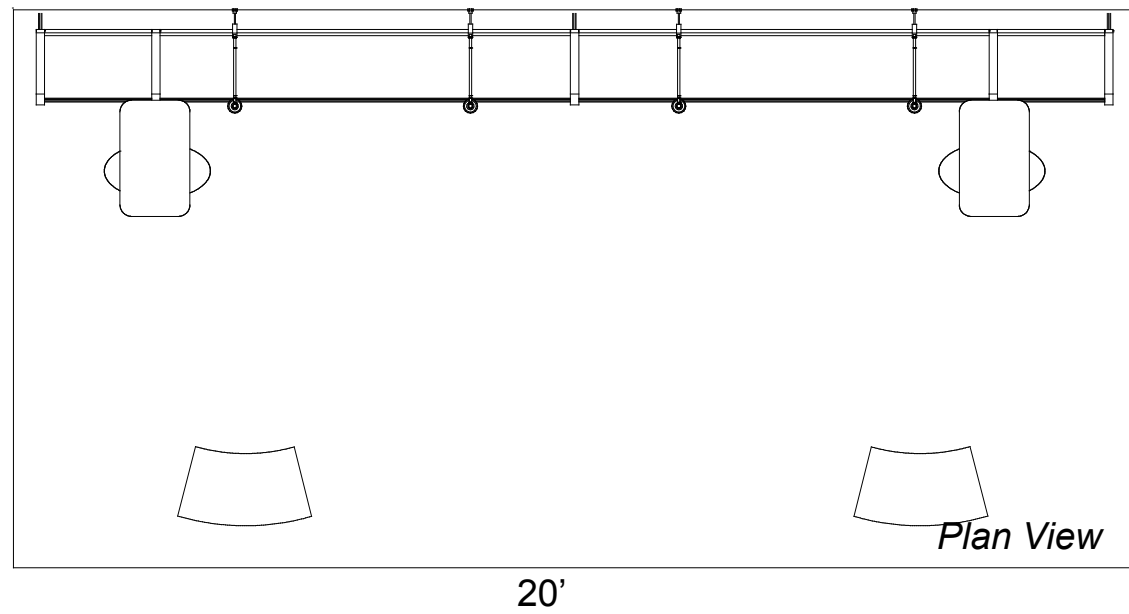

Additional Parts to Reconfigure Unit Into Two 10x10 Structures

For backwall assembly instructions, go to pg.1

For backwall assembly instructions, go to pg.2

Additional Parts

Part Number	Qty	Description
5	1	48.5" h Lower Curved Extrusion
6	1	48.5" h Upper Curved Extrusion
12	1	Backwall Support Leg Extrusion

Support Leg Attachment
(If accidentally removed from vertical)

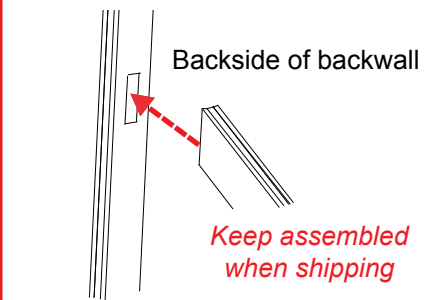

Connect support leg to vertical by placing lock into slot and tighten with Allen Wrench.

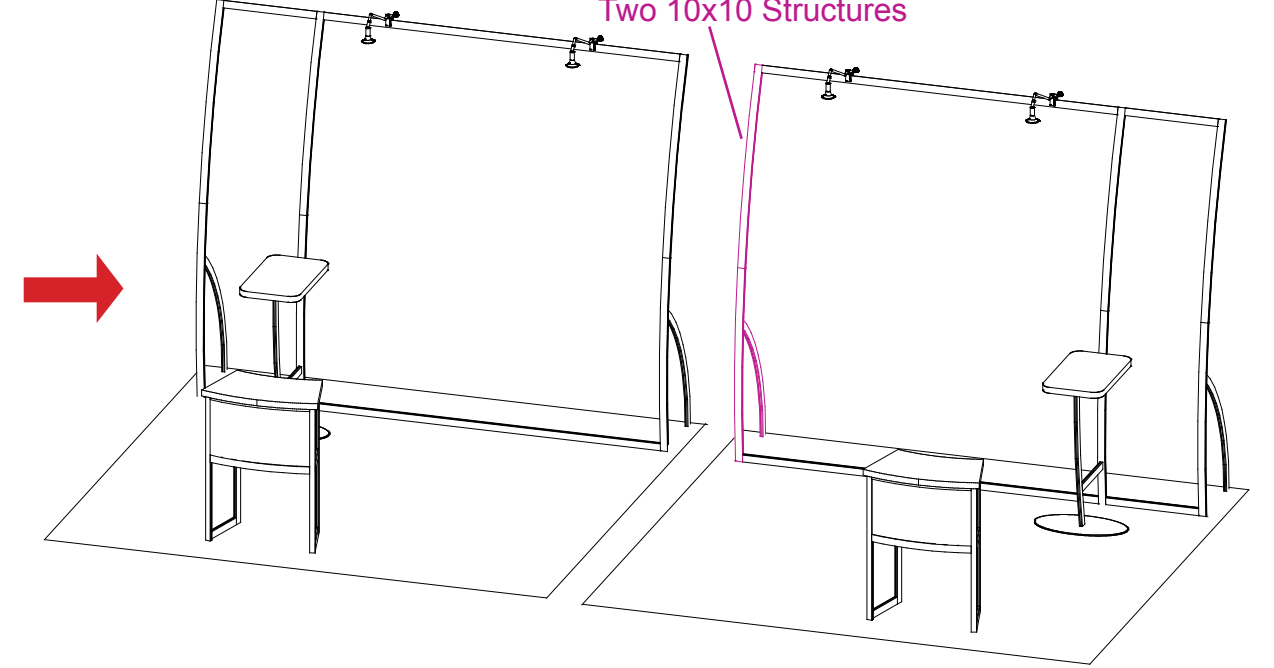
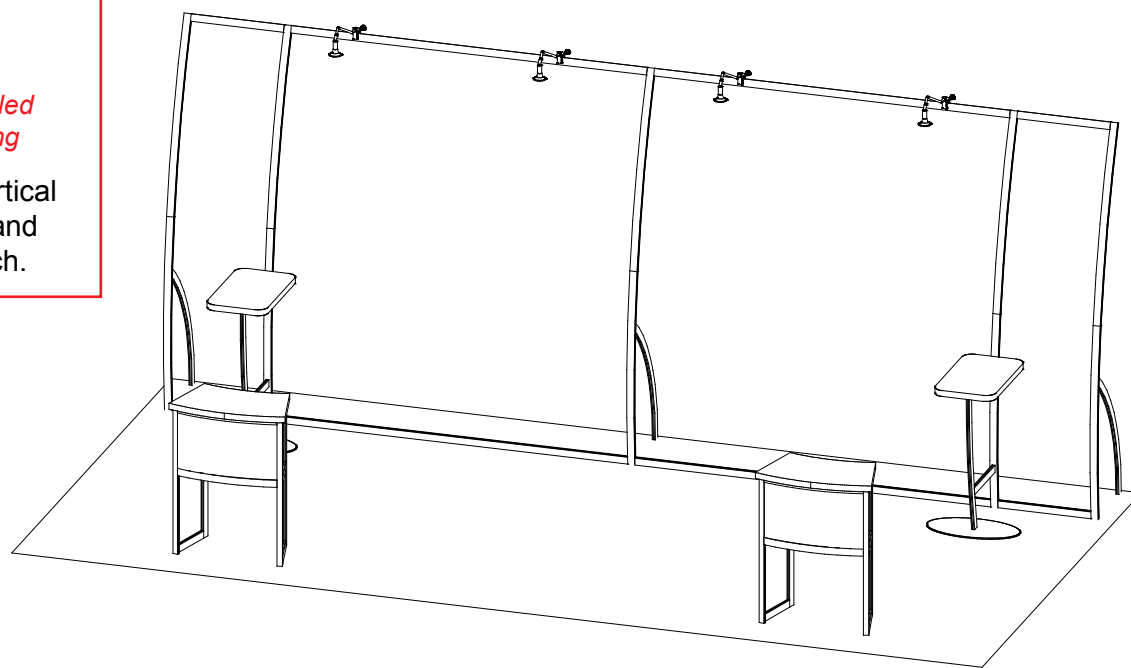

Additional Parts to Reconfigure Unit Into Two 10x10 Structures

WHEN DISASSEMBLING ALUMINUM EXTRUSION, TIGHTEN ALL SETSCREWS AND LOCKS TO PREVENT LOSS DURING SHIPPING

Top View of Each Level

Backwall Components

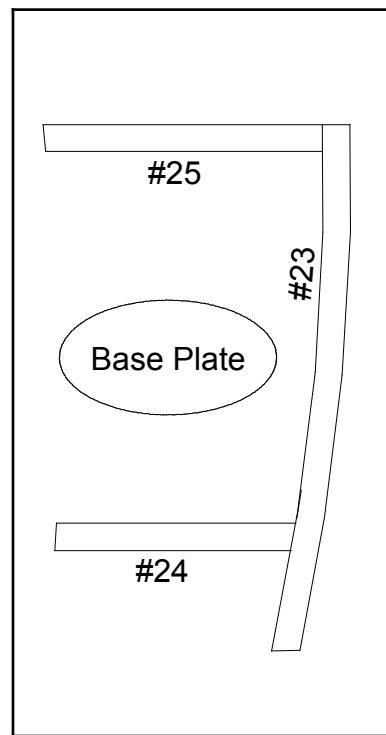

Level 1 (Bottom)

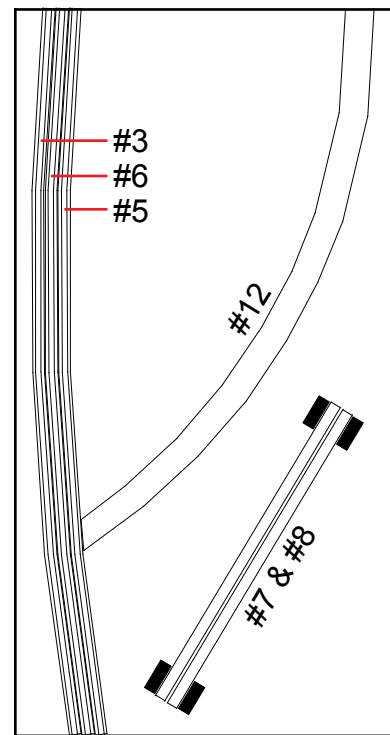

Level 2

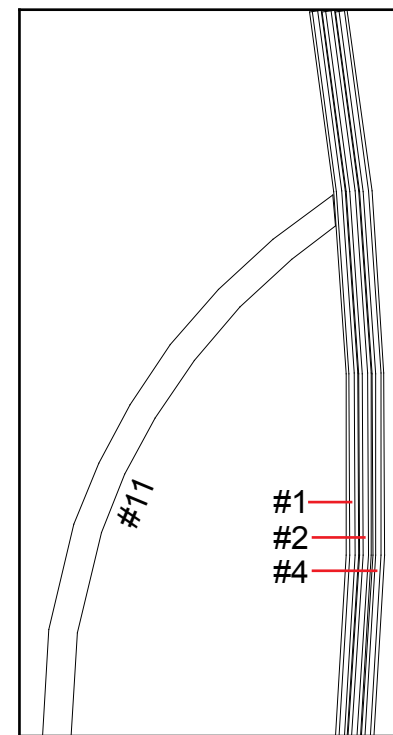

Level 3

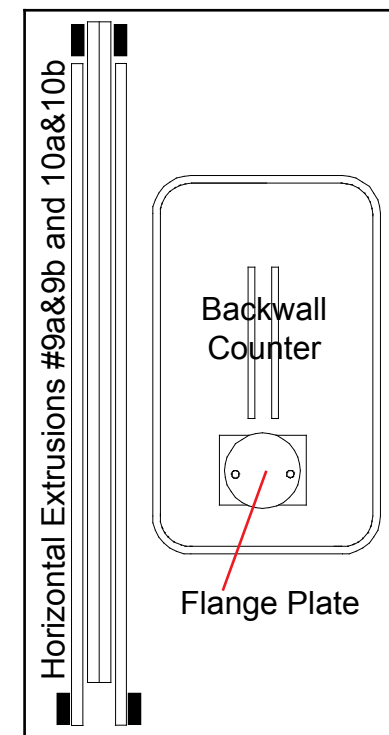

Level 4



WHEN DISASSEMBLING ALUMINUM EXTRUSION, TIGHTEN ALL SETSCREWS AND LOCKS TO PREVENT LOSS DURING SHIPPING

Top View of Each Level

Pedestal Components

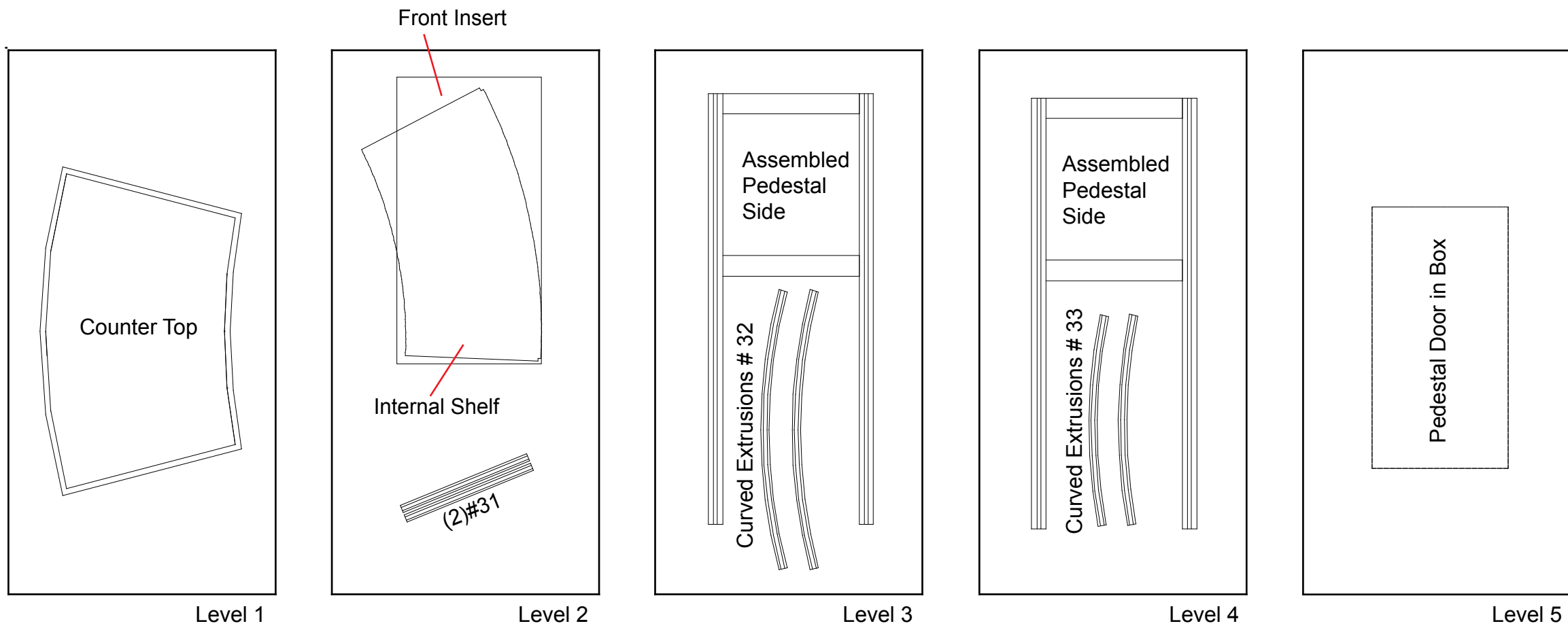

WHEN DISASSEMBLING ALUMINUM EXTRUSION, TIGHTEN ALL SETSCREWS AND LOCKS TO PREVENT LOSS DURING SHIPPING

Top View of Each Level

Backwall Components

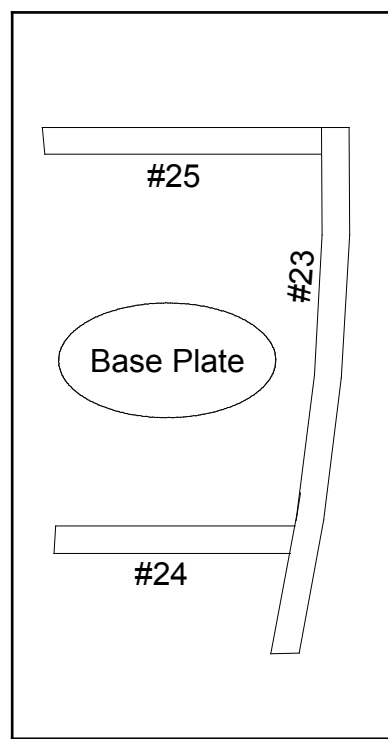

Level 1 (Bottom)

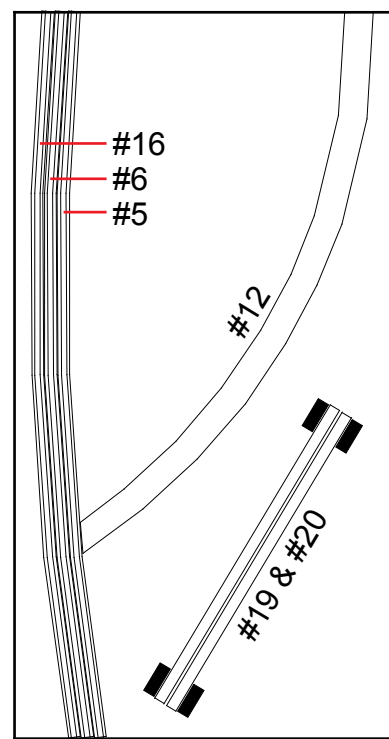

Level 2

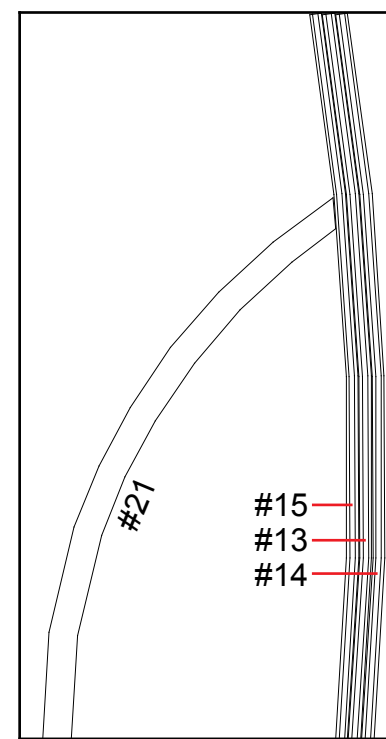

Level 3

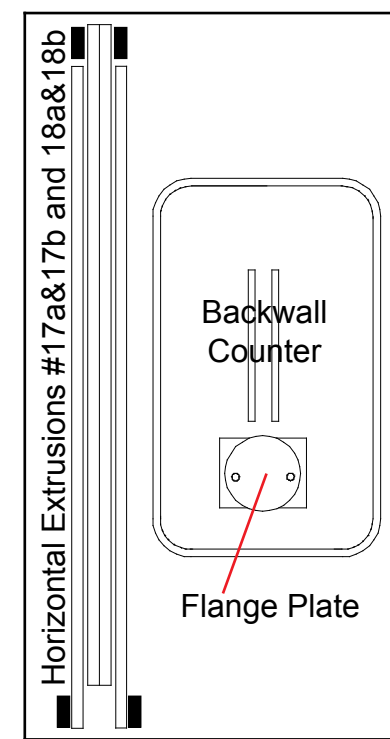

Level 4



WHEN DISASSEMBLING ALUMINUM EXTRUSION, TIGHTEN ALL SETSCREWS AND LOCKS TO PREVENT LOSS DURING SHIPPING

Top View of Each Level

Pedestal Components

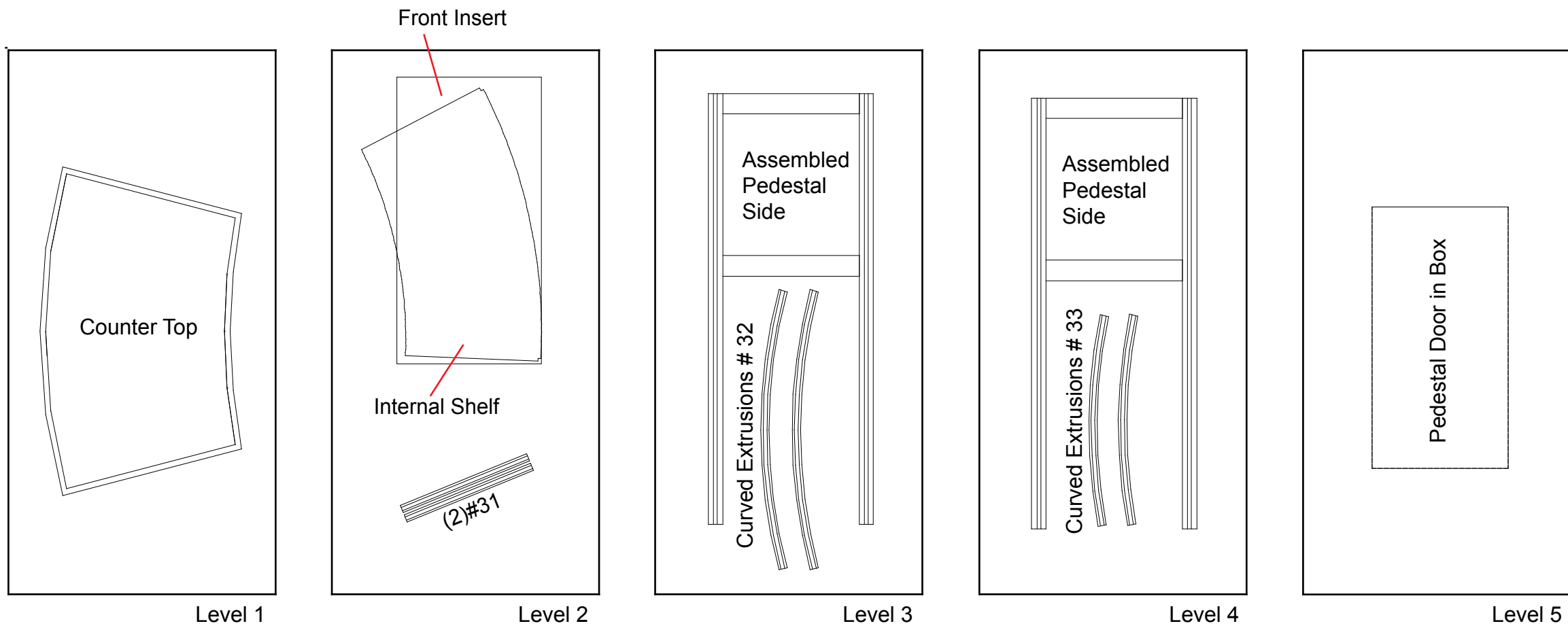

WHEN DISASSEMBLING ALUMINUM EXTRUSION, TIGHTEN ALL SETSCREWS AND LOCKS TO PREVENT LOSS DURING SHIPPING